

Ditec EL34

Control panel installation manual for QIK80EH barrier
 (Original instructions)

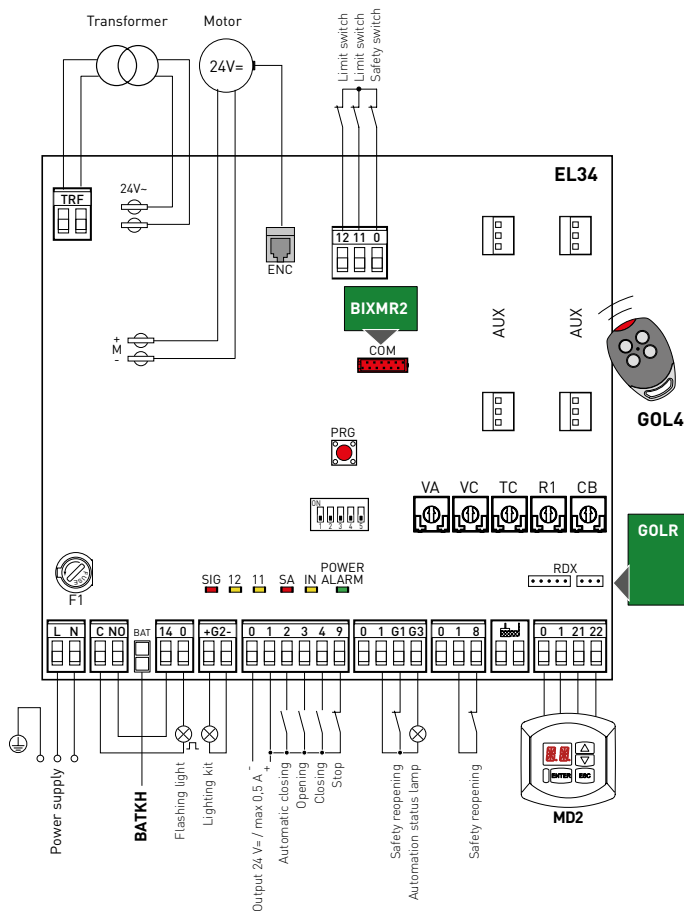

Index

	Subject	Page
1.	General safety precautions	21
2.	EC declaration of conformity	22
3.	Technical specifications	22
3.1	Applications	22
4.	Commands	23
5.	Outputs and accessories	24
6.	Settings	25
6.1	Trimmers	25
6.2	Dip-switches	26
6.3	Jumper	26
6.4	Signals	26
7.	Radio	27
8.	Start-up	28
9.	Troubleshooting	29
10.	Example of application for parallel automations	30
11.	Example of application for automations with two-way interlocking device without presence detection	31
12.	Example of application for automations with two-way interlocking device with presence detection	32
13.	Example of application for automations with two-way operating mode	33

Key



This symbol indicates instructions or notes regarding safety, to which special attention must be paid.



This symbol indicates useful information for the correct functioning of the product.

All the rights concerning this material are the exclusive property of ASSA ABLOY ES AB. Although the contents of this publication have been drawn up with the greatest care, ASSA ABLOY ES AB cannot be held responsible in any way for any damage caused by mistakes or omissions in this publication.

We reserve the right to make changes without prior notice. Copying, scanning and changing in any way are expressly forbidden unless authorised in writing by ASSA ABLOY ES AB.

1. General safety precautions



“Important instructions for installation safety.
Incorrect installation can cause serious injury”

This installation manual is intended for qualified personnel only. Installation, electrical connections and adjustments must be performed in accordance with Good Working Methods and in compliance with the present standards. Read the instructions carefully before installing the product. Bad installation could be dangerous.



The packaging materials (plastic, polystyrene, etc.) should not be discarded in the environment or left within reach of children, as these are a potential source of danger.

Before installing the product, make sure it is in perfect condition.

Do not install the product in explosive areas and atmospheres: the presence of inflammable gas or fumes represents a serious safety hazard.

The safety devices (photocells, safety edges, emergency stops, etc.) must be installed taking into account: applicable laws and directives, Good Working Methods, installation premises, system operating logic and the forces developed by the automation.



Before connecting the power supply, make sure the plate data correspond to that of the mains power supply. An omnipolar disconnection switch with minimum contact gaps of 3 mm must be included in the mains supply.

Check that there is an adequate residual current circuit breaker and a suitable overcurrent cut-out upstream of the electrical installation in accordance with Good Working Methods and with the laws in force.

When requested, connect the automation to an effective earthing system that complies with current safety standards.

During installation, maintenance and repair operations, cut off the power supply before opening the cover to access the electrical parts.



The electronic parts must be handled using earthed antistatic conductive arms. The manufacturer of the motorisation declines all responsibility in the event of component parts being fitted that are not compatible with the safe and correct operation.

Use original spare parts only for repairing or replacing products.

2. EC Declaration of Conformity

The manufacturer ASSA ABLOY ES AB, with headquarters in Lodjursgatan 10, SE-261 44 Landskrona, Sweden,

declares that the Ditec EL34 type control panel complies with the conditions of the following EC directives:

EMC Directive 2004/108/EC

Low Voltage Directive 2006/95/EC

R&TTE Directive 1999/5/EC

Landskrona, 14-02-2013

Marco Pietro Zini
(President EA)

3. Technical specifications

	QIK80EH
Power supply	230 V~ 50/60 Hz
F1 fuse	F2A
Motor output	24 V $\overline{=}$ 16 A
Accessories power supply	24 V $\overline{=}$ 0.5 A
Temperature	min -20° C max +55° C min -35° C max +55° C with NIO activated min -10° C max +50° C with batteries
Degree of protection	IP55
Radio frequency	433.92 MHz
Storable transmitters	200



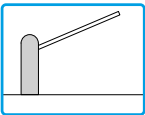

NOTE: The given operating and performance features can only be guaranteed with the use of DITEC accessories and safety devices.

3.1 Applications









4. Commands

Command	Function	Description
1 — 2	N.O. AUTOMATIC CLOSING	Permanently closing the contact enables automatic closing.
1 — 3	N.O. OPENING	With DIP1=ON, closing the contact activates an opening operation.
	STEP-BY-STEP	With DIP1=OFF, closing the contact activates an opening or closing operation in the following sequence: opening-stop-closing-opening. N.B.: if automatic closing is enabled, the stop is not permanent but has a duration set with the TC trimmer.
1 — 4	N.O. CLOSING	The closing operation starts when the contact is closed.
1 — 8	N.C. REVERSAL SAFETY CONTACT	Opening the safety contact triggers a reversal of the movement (reopening) during the closing operation.
1 — 9	N.C. STOP	Opening the safety contact stops the current operation.
1 — 9	N.O. OPERATOR PRESENT CONTROL	Opening of contact 1-9 enables the operator present function. - opening with operator present 1-3 [with DIP1=ON]; - closing with operator present 1-4. N.B.: any safety devices, automatic closing and plug-in cards in the AUX1, AUX2 and RDX housings are disabled.
1 — G1	N.C. REVERSAL SAFETY CONTACT	Opening the safety contact triggers a reversal of the movement (reopening) during the closing operation.
	N.O. TRANSMITTER STORAGE AND CANCELLATION	 WARNING: the storage module MUST BE inserted. Transmitter storage: - press the PRG key (the SIG LED turns on), - proceed with transmission from the transmitter to be stored (the SIG LED flashes), - wait 10 s for storage to be completed (the SIG LED turns off). Transmitter cancellation: - press the PRG key for 3 s (the SIG LED flashes), - press the PRG key again for 3 s (the SIG LED flashes faster).
	SETTINGS RESET	 WARNING: the storage module must NOT be inserted. - press the PRG key for 4 s (the IN LED flashes), - press the PRG key within 4 sec for another 2 sec (the IN LED comes on). The SETTINGS RESET deletes all the remote software settings made using the MD2 display module. After SETTINGS RESET it is possible to adjust the control panel directly. WARNING: if the MD2 display module is disconnected from the control panel, a SETTINGS RESET must be performed.

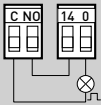

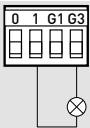
Warning: make a jumper for all NC contacts if not in use. The terminals with the same number are equal.





5. Outputs and accessories

Output	Value - Accessories	Description
	24 V \approx 0,5 A	Accessories power supply. Power supply output for external accessories, including automation status lamps.
<p>AUX1 AUX2</p>	SOFA1-SOFA2 GOPAV	The control panel is fitted with two housings for plug-in cards such as radio receivers, magnetic loops, etc. Operating of the plug-in card is selected using DIP1. WARNING: the plug-in cards must be inserted and removed with the power supply disconnected.
	LAMPH 24 V \approx 50 W	Flashing light. The flashing light activates simultaneously with the opening and closing operation.
	QIKAFE 24 V \approx 1 A	24V electric block. It is activated when the barrier is closed.
	QIKLUX 24 V \approx 300 mA max	Lighting kit. On with barrier closed. Flashing with barrier operating. Off with barrier open
	24 V \approx 3 W	Automation status light (proportional) The light goes off when the automation is closed. The light comes on when the automation is open. The light flashes with a variable frequency while the automation is operating.
	BIXAL	If the GOLR radio receiver is used, connect the supplied antenna wire (173 mm), or alternatively the BIXAL antenna, using a coaxial cable, type RG58.
	MD2 DMCS	Allows connection of the MD2 display module for advanced control of the functions or connection of the DMCS software.
	GOLR	The control panel is fitted with a housing for a plug-in card such as a GOLR radio receiver. Operating of the plug-in card is selected using DIP1. WARNING: the plug-in cards must be inserted and removed with the power supply disconnected.
	BIXMR2	If the GOLR radio receiver is used, the storage module allows the remote controls to be stored. It allows the functioning configurations to be saved using the SF function of the MD2 display module. The saved configurations can be recalled via the SF function of the MD2 display module. If the control panel is replaced, the BIXMR2 storage module being used can be inserted in the new control panel. Warning: the storage module must be inserted and removed with the power supply disconnected.



Output	Value - Accessories	Description
	BATKH 2x12 V 2Ah	<p>Barrier operation.</p> <p>The batteries are kept charged when the power supply is on. If the power supply is off, the panel is powered by the batteries until the power is re-established or until the battery voltage drops below the safety threshold. The panel turns off in the last case.</p> <p>WARNING: the batteries must always be connected to the control panel for charging. Periodically check the efficiency of the batteries. N.B.: the operating temperature of the rechargeable batteries is approximately +5°C/+40°C.</p>

6. Settings















6.1 Trimmers

Trimmer	Description
VA - VC 	VA - Opening speed adjustment. Adjusts the opening speed. VC - Closing speed adjustment. Adjusts the closing speed.
TC 	Setting automatic closing time. From 0 to 120 s.
R1 	Thrust adjustment on obstacles. The control panel is equipped with a safety device that stops motion if an obstacle is encountered during the opening operation and reverses motion during the closing operation. R1=MIN gives maximum obstacle sensitivity (minimum thrust). With R1=MAX, there is maximum thrust.
CB 	Deceleration distance when closing. Controls the deceleration distance when closing to allow an optimum approach.

6.2 Dip-switches

DIP	Description	OFF 	ON 
DIP1	Command functions 1-3. N.B.: also sets operating of the plug-in cards connected on AUX1, AUX2 and RDX.	Step-by-step.	Opening.
DIP2	Selecting opening direction. The opening direction is intended by viewing the automation from the side being examined.	Opening to the right.	Opening to the left.
DIP3	Opening with safety devices open.	Enabled. The opening of contacts 1-8 with the automation idle allows immediate opening by means of command 1-3 or remote control.	Disabled. The opening of contact 1-8 with the automation idle prevents all operations.
DIP4	FUTURE USE	/	/
DIP5	Electronic antifreeze system. Maintains motor efficiency even at low ambient temperatures.	Enabled.	Disabled.

6.3 Signals

LED	On	Flashing
POWER 	24V  power supply.	 Encoder not working.  Current overload on flashing light output.  Shortcircuiting of flashing light driver.
SA 	Indicates that at least one of the safety contacts is open.	/
IN 	Activated at every command and adjustment to the dip-switch.	 SETTINGS RESET in progress.
11 	Indicates that the 0-11 limit switch contact is open.	/
12 	Indicates that the 0-12 limit switch contact is open.	/
SIG 	Transmitter enabling/storage phase.	 Radio transmission of a stored remote control received.  Radio transmission of an unstored remote control received.  Transmitters being cancelled.  Damaged storage.

7. Radio

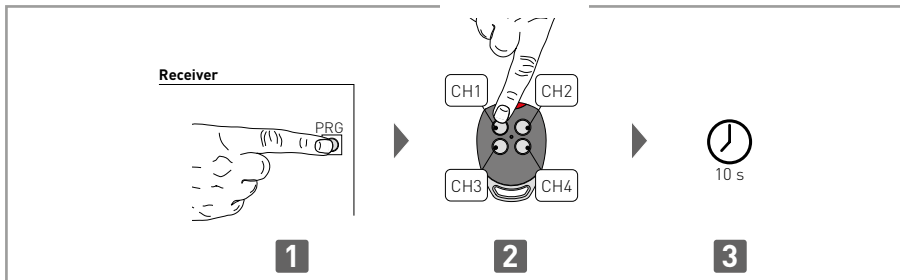

The control panel is equipped with a radio receiver with a frequency of 433.92 MHz.

The antenna consists of a rigid wire, 173 mm long, connected to the ANT clamp.

It is possible to increase the range of the radio by connecting the antenna of the flashing lights, or by installing the tuned BIXAL antenna.

N.B.: To connect the external antenna to the control panel, use a coaxial cable, type RG58 (max. 10 m).

Check that the storage module is inserted in the COM connector.

Up to 200 remote controls can be stored in the storage module.

Transmitter storage:

- Press the PRG key on the radio receiver or on the control panel; the SIG indicator LED lights up;
- Proceed with transmission by pressing the CH keys on the remote control that you want to store (within the range of the radio receiver). The remote control is now stored. During this phase, the SIG indicator LED flashes. When the SIG LED comes on again, you can validate another remote control. Validate all the new remote controls by making a transmission as indicated;
- You automatically exit the procedure 10 seconds after the last transmission, or you can press the PRG key again (the SIG LED goes off).

Up to four CH keys of a single remote control can be stored:

- If only one (any) CH key of the remote control is stored, command 1-3 (step-by-step/opening) is carried out;
- If 2-4 CH keys of a single remote control are stored, the functions matched with the CH keys are as follows:
 - CH1 = command 1-3 step-by-step/opening;
 - CH2 = NO SETTING SELECTED;
 - CH3 = command to switch on/off the courtesy light;
 - CH4 = stop command, equivalent to impulsive command 1-9.

Transmitter cancellation:

- Hold down the PRG key for 3 s; the SIG LED starts to flash;
- To cancel all the remote controls from the memory, press the PRG key again, keeping it pressed for 3 s;
- To cancel a single remote control, press any one of the previously memorised CH keys of the remote control to be cancelled;
- The cancellation is confirmed by the quick flashing of the SIG LED.

If the control panel is replaced, the storage module being used can be inserted in the new control panel.



WARNING: the storage module must be inserted and removed with the power supply disconnected.



For further information see the user manual for GOL series remote controls.

8. Start-up



WARNING: The operations in point 5 are performed without safety devices.
The trimmers can only be adjusted with the automation idle.
The automation automatically slows when approaching the stops.

- Make a jumper for NC safety contacts.
- Move the bar into the opening and closing position by hand.
Adjust the mechanical stops and limit switches as indicated in the QIK80EH barrier installation manual.
- Set the correct opening direction with DIP2, as shown on page 26.
- Connect the power supply cable to terminals L-N-⊕ as shown on page 19.
- Switch on and check the automation is operating correctly with the subsequent opening and closing commands.
- Check that the limit switches are activated.
- Connect the safety devices (removing the relative jumpers) and check they function correctly. If required, activate automatic closing with command 1-2 and adjust the time with the TC trimmer.
- Set the desired opening and closing speeds with the VA and VC trimmers.
- Adjust the deceleration distance when closing with the CB trimmer.
- Set the obstacle thrust with the R1 trimmer.
Warning: Ensure that the forces exerted by the door wings are compliant with EN12453-EN12445 regulations.
- Connect any other accessories and check they are functioning.



N.B.: in the event of servicing or if the control panel is to be replaced, repeat the start-up procedure.

9. Troubleshooting

Problem	Possible causes	Operation
The automation does not open or close.	No power. (POWER ALARM LED off).	Check that the control panel is powered correctly.
	Short circuited accessories. (POWER ALARM LED off).	Disconnect all accessories from terminals 0-1 (a voltage of 24V= must be present) and reconnect them one at a time.
	Blown line fuse. (POWER ALARM LED off).	Replace fuse F1.
	Safety contacts are open. (SA LED on).	Check that the safety contacts are closed correctly (NC).
	SAFETY SWITCH release microswitch open. (LEDs 11 and 12 on).	Check that the hatch is closed correctly and the microswitch makes contact.
	The remote control does not work.	Check that the radio receiver and storage module are present. Check that the transmitters have been correctly stored on the radio.
	Photocells activated. (SA LED on).	Check that the photocells are clean and operating correctly.
	The automatic closing does not work.	Check that contact 1-2 is closed.
The external safety devices are not activated.	Incorrect connections between the photocells and the control panel.	Connect NC safety contacts together in series and remove any jumpers on the control panel terminal board.
The automation opens/closes briefly and then stops.	Encoder disconnected, false encoder contacts, encoder fault. (flashing POWER ALARM LED).	Check that the encoder is connected correctly, clean the contacts by connecting and disconnecting the encoder plug on the contacts, replace encoder.
	Motor leads crossed. (flashing POWER ALARM LED).	Check the motor leads.
	There is friction or the spring tension is not correct.	Manually check that the automation moves freely and check the R1 adjustment. Check spring tension.
The remote control has limited range and does not work with the automation moving.	The radio transmission is impeded by metal structures and reinforced concrete walls.	Install the antenna outside.
		Substitute the transmitter batteries.



N.B.: if the MD2 display module is present, consult the Alarm and fault visualisation chapter in the relevant installation manual.

10. Example of application for parallel automations

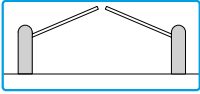

With these settings, an obstacle during closing will cause both barriers to reopen.
An obstacle during opening will cause only the barrier involved to stop.

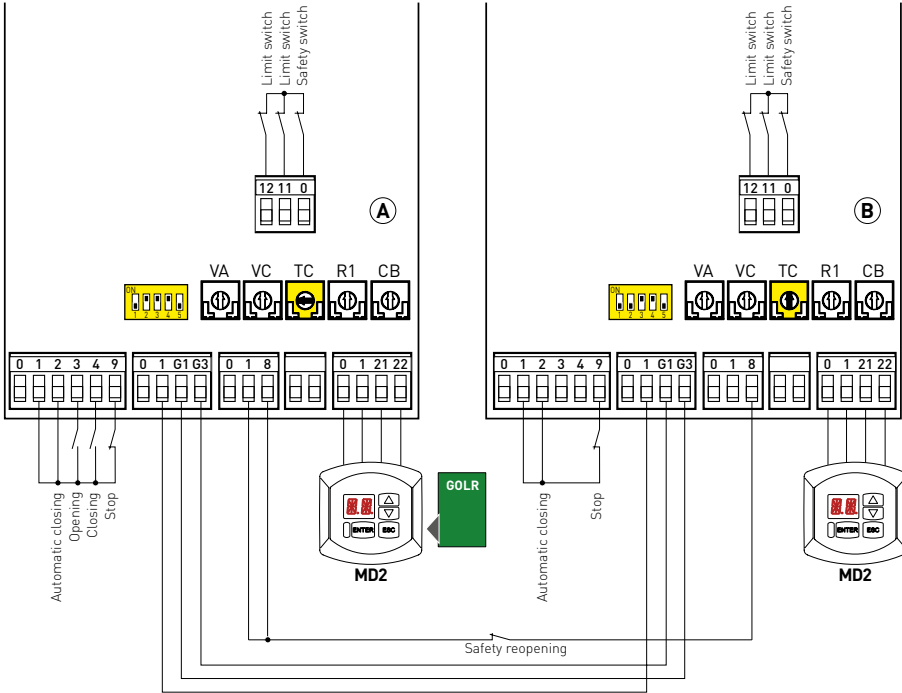

- 1- Disconnect connectors 0-1-G1-G3 from the control panels.
- 2- Using the MD2 display modules connected to the control panels, set the following parameters on both automations:
 Setting advanced parameters AP > AA > ON
 Setting input mode AP > G1 > SY
 Setting automation parallel mode AP > PA > 01
- 3- Reconnect connectors 0-1-G1-G3.
- 4- Enable automatic closing on both automations by making a jumper for contacts 1-2.
- 5- Set the automatic closing time of automation A with the TC trimmer as desired, set the TC trimmer of automation B to maximum. (With this setting the automations will perform the closing operation at the same time as the time set with the TC trimmer of automation A expires).
- 6- Only one GOLR radio receiver should be installed.
- 7- If QIKLUX lighting kits are present, set AP>G2=03 or AP>G2=02 to synchronise the lighting with the closed automations.

11. Example of application for automations with two-way interlocking device without presence detection

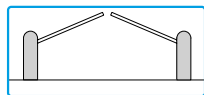

With these connections and settings, command 1-3 starts an opening operation of barrier A (or B) which closes after the time set with TC. When time TO elapses, barrier B will open and will close after the time set with TC.

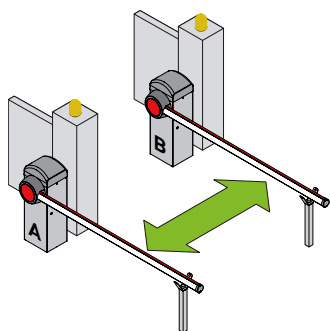
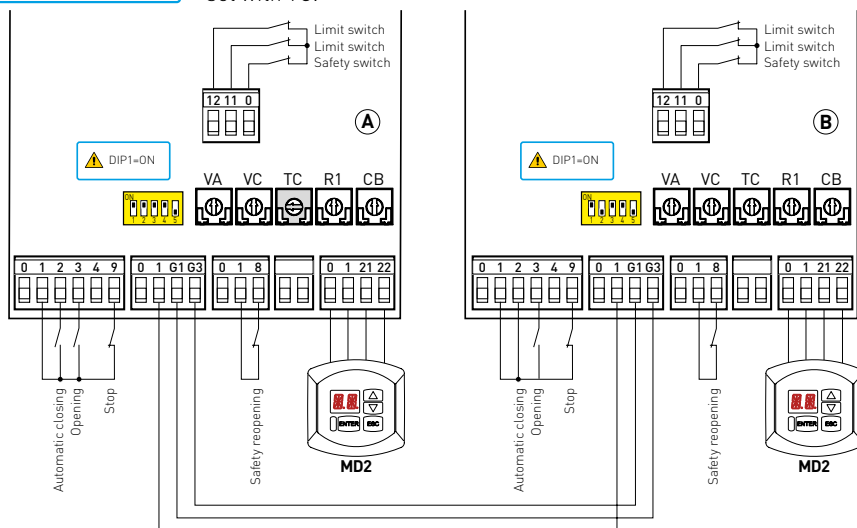

- 1- Disconnect connectors 0-1-G1-G3 from the control panels.
- 2- Using the MD2 display modules connected to the control panels, set the following parameters on both automations:
Setting advanced parameters AP > AA > ON
Setting input mode AP > G1 > SY
Setting automation parallel mode AP > PA > 02
- 3- Reconnect connectors 0-1-G1-G3.
- 4- Set DIP1=ON on both automations.
- 5- The radio controls will have to be handled as opening commands 1-3 (RO>C1>1-3)
- 6- Enable automatic closing on both automations by making a jumper for contacts 1-2.
- 7- Adjust the automatic closing time with the TC trimmer as required.
- 8- Set the opening delay time (from 0 to 30 s).
- 9- The reservation function (PG) can be enabled if a vehicle arrives in the same direction while another one is still between the barriers BC>PG>ON. A second opening command is stored and executed as soon as the cycle in progress terminates.



WARNING: the opening commands are disabled during the interlocking cycle



In the event of an emergency, the operator present commands can be used (contact 1-9).

12.Example of application for automations with one-way interlocking device with presence detection

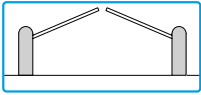

With these connections and settings, command 1-3 starts an opening operation of barriers.
Automatic closing will only be enabled when the vehicle activates the detection device.

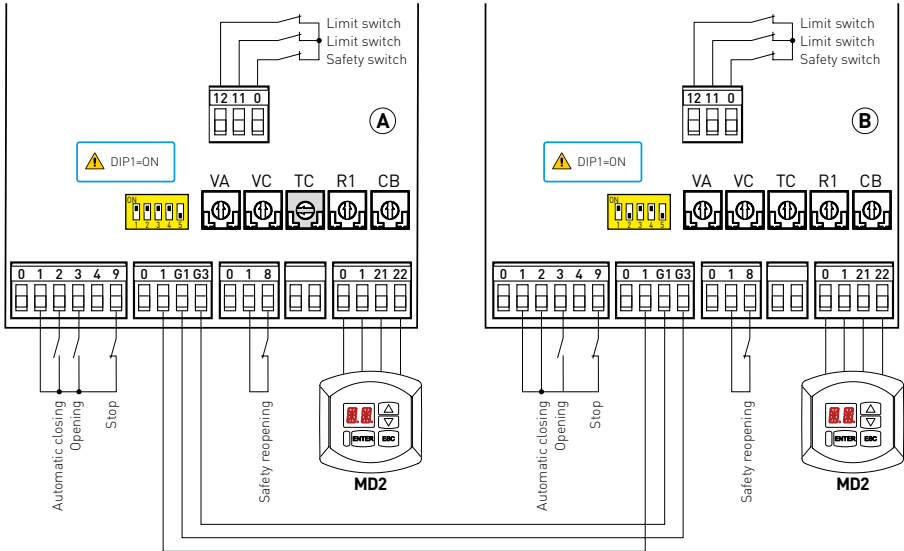

For the connections, refer to par. 11.

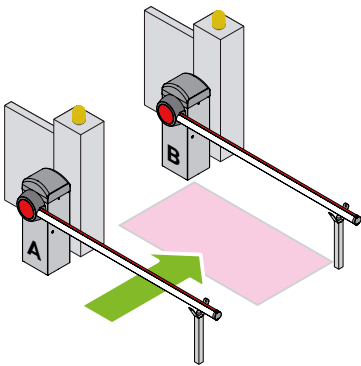

You can connect two barriers with one-way operating mode with presence detection by installing a detection device between the two barriers (e.g. magnetic loop). Connect terminals 1-2 of the entrance A barrier and automatic closing will only be enabled when the vehicle activates the detection device.

13. Example of application for automations with two-way operating mode with vehicle direction detection.

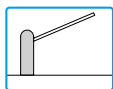

With these settings, the control panel recognises vehicles as they enter and disables the AUX1 command for the set period T0; The counter starts when command 1-8 is released, after command 1-3 is given.

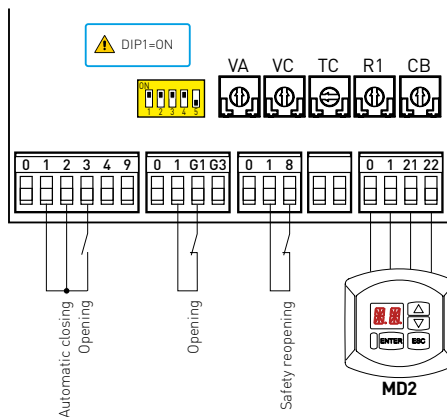
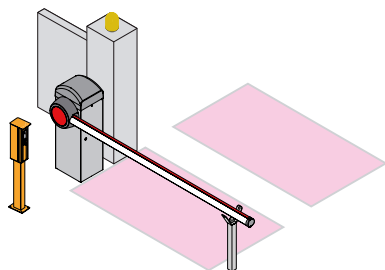

In the event of access to car park after paying and free exit:

- 1- Using the MD2 display module, set the following parameters:
 BA>AN>3A
 AP>D8>LO with this setting, command 1-8 performs a stop and not a reversal.
 BA>T0>.. set the delay time during opening of command 1-G1.
 BA>TS>.. set the automatic closing time restore time after release of command 1-8.
- 2- Connect the outer side opening command (e.g. LAN60) to terminals 1-3.
- 3- Connect the safety device to terminals 1-8.
- 4- Insert the LAB9 card on AUX1.
- 5- Enable automatic closing with jumper 1-2.
- 6- Adjust the TC trimmer.
- 7- Set DIP1=ON
- 8- Set the delay time T0.
- 9- Immediate reclosing of the barrier is possible [BA>TS>00].

Exiting vehicles open the barrier with the AUX1 command.

We recommend setting AP>D8>LO to prevent unauthorised access.



ASSA ABLOY Entrance Systems AB
Lodjursgatan 10
SE-261 44, Landskrona
Sweden
© ASSA ABLOY

