

CHAMBERLAIN
ELITE™



Instruction Manual
ROBO SWING R900™
GATE OPERATOR FOR SINGLE FAMILY HOMES

installation instructions and manual book
for architects, general contractors and dealers

TABLE OF CONTENTS

Role of Specifiers and Designers	2
Role of Dealers, Installers and Trained Gate System Technicians	2
Role of End Users / Home Owners	3
Swing Gate Systems	3
Warnings and Precautions	4-6
Safely Operating Gate	7
Configuration and Specifications	8
Concrete Pad and Gate Attachment	9
Standard Installation	10
Compact Installation	11
Gate Arm Installation	12
Gate Movement Direction	13
Adjustment of Output Shaft	14
Earth Ground Rod	15
DC Power Supply Connection	16
“Optional” Solar Panel	17
Surge Suppressor Terminal Input Connections	18
Adjusting Gate Traveling Distance	19
Timer Adjustment	19
Reversing Sensor	20
Warning Placard Placement	20
Emergency Release	21
Safety Device Wiring	22
“Optional” Input Board	23
Maglock Wiring Connection	24
Optional 12 VDC Photo Beam Wiring	25
3-Push Button Wiring Connection	26
3-Push Button Wiring Master / Second	27
Single Operator Loop Size and Placement	28
Master / Second Loop Size and Placement	29
Loop Installation and Number of Wire Turns	30
Wiring Loop Detector to Operator	31
Master and Second Operators with Timer	32
Master and Second Operators without Timer	33
Control Board Functions	34
Control Board LED Descriptions	35-36
Troubleshooting	
How to Reset Breaker Switch / How to Check Fuses	37
Gate will not close! / Gate will not open!	38
If you hear a “BEEP” sound (Audio Alarm)	39
Robo Swing Parts Illustrations, Robo Swing Parts List	40-41
Maintenance	41
Elite Robo Swing Accessories	42
Owners Checklist of Installation	43

ROLE OF SPECIFIERS AND DESIGNERS

Specifiers and designers should design an automatic vehicular gate system to:

- Utilize an operator suited for gate system type, size, frequency of use, location and user population.
- Separate pedestrian access from vehicle access.
- Reduce or eliminate pinch points.
- Reduce risk of entrapment injuries by minimizing all gaps in the gate and enclosing the area of the travel of the gate.
- Secure controls from unauthorized use.
- Locate all controls out of reach from the gate.
- Allow the user full view of the gate when operating.
- Consider special populations, such as children or the elderly.
- Be consistent with DASMA's Automatic Gate Opener System Safety Guide.

ROLE OF DEALERS, INSTALLERS AND TRAINED GATE SYSTEM TECHNICIANS

Installers, during the course of the installation proceedings for each job, should:

- Confirm that the gate operator being installed is appropriate for the application.
- Confirm that the gate is designed and built according to current published industry standards.
- Confirm that all appropriate features and accessory devices are being incorporated, including both primary and secondary entrapment protection devices.
- Make sure that the gate works freely before installing the operator.
- Repair or service worn or damaged gate hardware before installing the operator.
- Install the gate operator according to the manufacturer's installation instructions.
- Adjust the operator clutch or load-sensing device to the minimum force setting that allows reliable gate operation.
- Install operator inside fence line (DO NOT install operator on public side of fence line).
- Install a proper electrical ground to a gate operator.
- Install keypad controls where users cannot touch, or reach through gate while operating controls.
- Install controls where user has full view of gate operation.
- Test all features for proper functions before placing the automatic vehicular gate into service.
- Demonstrate the basic functions and safety features of the gate system to owners/end users/general contractors, including how to turn off power and how to operate the manual disconnect feature.
- Leave safety instructions, product literature, installation manual and maintenance manual with end user.
- Explain to the owners the importance of a service contract that includes a routine re-testing of the entire system including the entrapment protection devices, and explain the need for the owners to insure that this testing is performed routinely.
- Offer the owner/end user a maintenance contract, or contact them regularly to offer maintenance.

ROLE OF END USERS/HOME OWNER

End users should be made aware that they must:

- Contact a trained gate systems technician to maintain and repair the gate system (End users should never attempt to repair the gate)
- Retain and utilize the installation and maintenance manual and safety instructions.
- Routinely check of all gate operator functions and gate movement.
- Discontinue use if safety systems operate improperly, the gate is damaged, or the gate is difficult to move.
- Never overtighten the operator clutch of load sensing device to compensate for a damaged or stiff operating gate.
- Keep all obstructions clear of the vicinity of the path of the gate system.
- Actively discourage pedestrian use of the vehicular gate operating system.
- Prevent anyone from playing near any part of the gate system.
- Never allow anyone to climb under, over or through a gate or the adjacent fence area.
- Never allow children to operate gate
- Keep portable controls out of reach of children.
- Never allow anyone to install an operating control within reach of the gate.
- Always be certain that the gate area is clear of pedestrians before operating the gate.

SWING GATE SYSTEMS

- **Entrapment Zone Hazard** - Body parts may become entrapped between a gate and a stationary object when the gate begins to move, which can result in serious injury or death. Pedestrians must stay clear of the gate path, and any area where gate motion is close to stationary objects.
- **Pinch Points Hazard** - The opening mechanism may have arms that can overlap with a scissoring effect, which can result in serious injury. Pedestrians must stay clear of the opening mechanism at all times, particularly when gate is opening.

WARNINGS AND PRECAUTIONS

IMPORTANT!

*Instructions regarding **Robo Swing** Installation.*

- A) Install the gate operator only when all exposed pinch points are eliminated or guarded.

- B) *The operator is intended for installation only on gates used for vehicles. Pedestrians must be supplied with a separate access opening.***

- C) The gate must be installed in a location so that enough clearance is supplied between the gate and adjacent structures when opening and closing to reduce the risk of entrapment. Swinging gates shall not open into public access areas.

- D) The gate must be properly installed and work freely in both directions prior to the installation of the gate operator.

- E) Controls must be far enough from the gate so that the user is prevented from coming in contact with the gate while operating the controls.

WARNINGS AND PRECAUTIONS

- F)** For a gate operator utilizing a non-contact sensor such as a photo beam:
- 1)** See instructions on the placement of non-contact sensor for each type of application.
 - 2)** Care shall be exercised to reduce the risk of nuisance tripping, such as when a vehicle trips the sensor while the gate is still moving.
 - 3)** One or more non-contact sensors shall be located where the risk of entrapment or obstruction exists, such as the perimeter reachable by a moving gate or barrier.
- G)** For a gate operator utilizing a contact sensor such as an edge sensor:
- 1)** A hardwired contact sensor shall be located and its wiring arranged so that the communication between the sensor and the gate operator is not subjected to mechanical damage.
 - 2)** A wireless contact sensor such as the one that transmits radio frequency (RF) signals to the gate operator for entrapment protection functions shall be located where the transmission of the signals are not obstructed or impeded by building structures, natural landscaping or similar obstruction. A wireless contact sensor shall function under the intended end-use conditions.
 - 3)** One or more contact sensors shall be located on the inside and outside leading edge of a swing gate. Additionally, if the bottom edge of a swing gate is greater than 6 inches (152 mm) above the ground at any point in its arc of travel, one or more contact sensors shall be located on the bottom edge.

WARNINGS AND PRECAUTIONS

IMPORTANT SAFETY INSTRUCTIONS!

WARNING - *To reduce the risk of Injury or Death:*

- 1. READ AND FOLLOW ALL INSTRUCTIONS.**
- 2. *Never*** let children operate or play with gate controls. Keep the remote control away from children.
- 3. *Always keep people and objects away from the gate.***
NO ONE SHOULD CROSS THE PATH OF THE MOVING GATE!
- 4.** Test the gate operator monthly. The gate ***MUST*** reverse on contact with a rigid object or stop when an object activates the non-contact sensors. After adjusting the force or the limit of travel, retest the gate operator, Failure to adjust and retest the gate operator properly can increase the risk of injury or death.
- 4.** Use the emergency release only when the gate is not moving. Make sure the power for the gate operator is ***off***.
- 5. *KEEP GATES PROPERLY MAINTAINED.*** Read the manual. Have a qualified service person make repairs to the gate or gate hardware.
- 6. *The entrance is for vehicles only. Pedestrians must use separate entrance.***
- 7. *SAVE THESE INSTRUCTIONS.***

SAFELY OPERATING GATE



The Robo Swing is for Single Home Applications

DO NOT Use for Apartment or Condominium Applications.

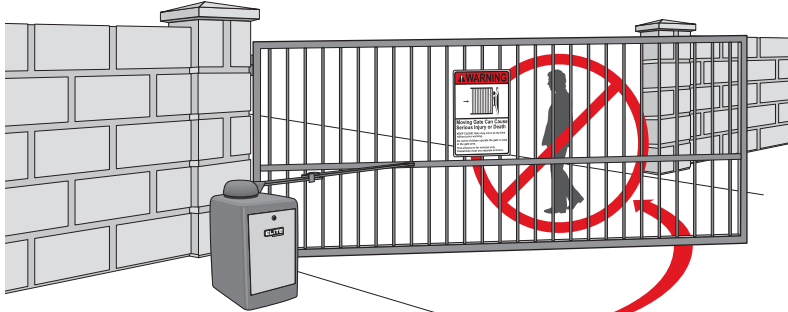

Property owners must never let pedestrians cross the path of a moving gate!

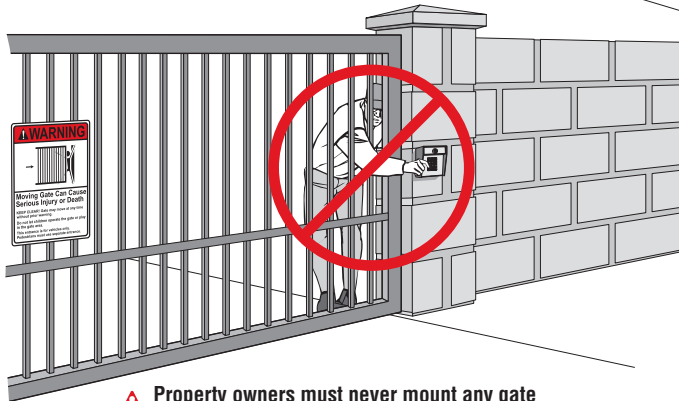

Property owners must never mount any gate operating device accessible through the gate!

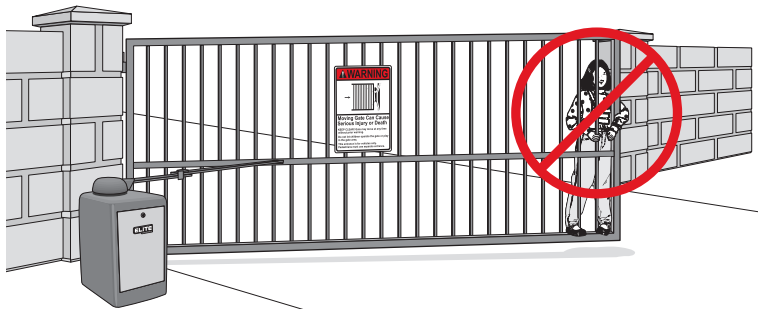

Property owners must never let anyone hang or ride on the gate!

CONFIGURATION AND SPECIFICATIONS

All “Pinch Points” **MUST** have protective safety devices.

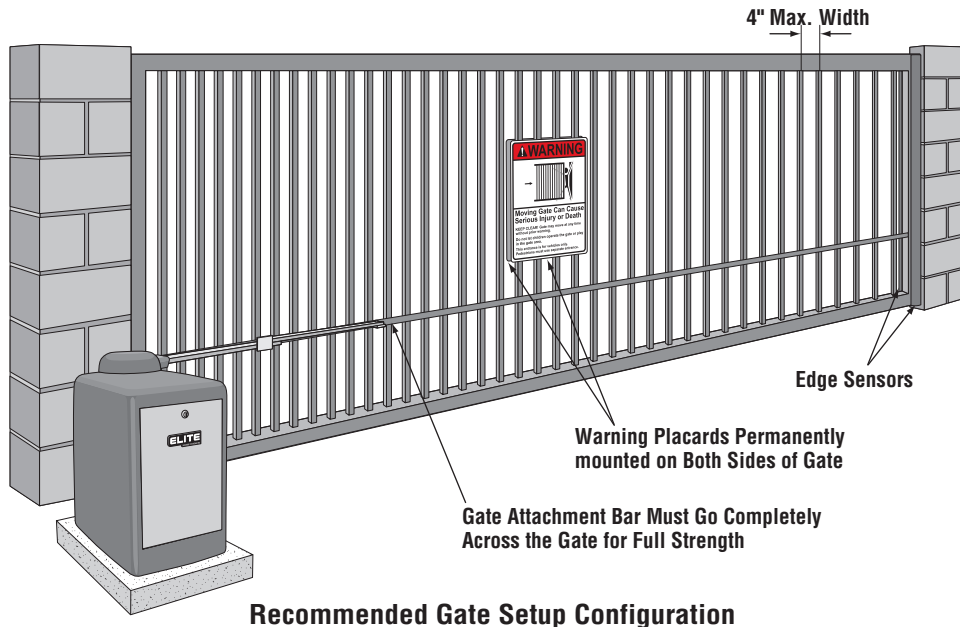

Robo Swing Specifications:

Gate Speed – 15 - 17 seconds per 90 cycle

Maximum Gate Length – 16 feet

Maximum Gate Weight – 400 pounds

Maximum Cycles – 250 cycles per day with Elite's Plug-In Transformer. (Gate size 16 ft x 6 ft)

– Solar power cycles per day varies, Contact Chamberlain Elite for more Information

– Battery back-up cycles (50 cycles total)

AC Power Supply – 25 Vdc 1.6 Amp Plug-In Transformer (Part # **A POW-1**)

AC Power Supply Wire – 14 gauge or greater landscape lighting cable rated for direct burial and 300 watts at maximum length of 1000 ft

DC Power Supply – Built-in, back-up for AC or Solar power failure only

Solar Power – Optional (Part # **SOLAR 3**)



Be sure to read and follow all Chamberlain Elite's instructions before installing and operating any Chamberlain Elite product. Always disconnect the gate operator's power source before repairs are attempted. Chamberlain Elite Access Systems, Inc. is not responsible for improper installation or failure to comply with local building codes.

CONCRETE PAD AND GATE ATTACHMENT

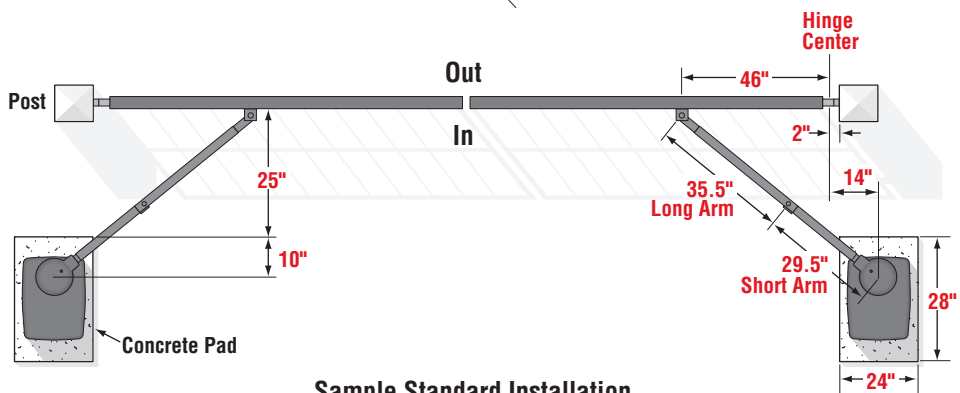
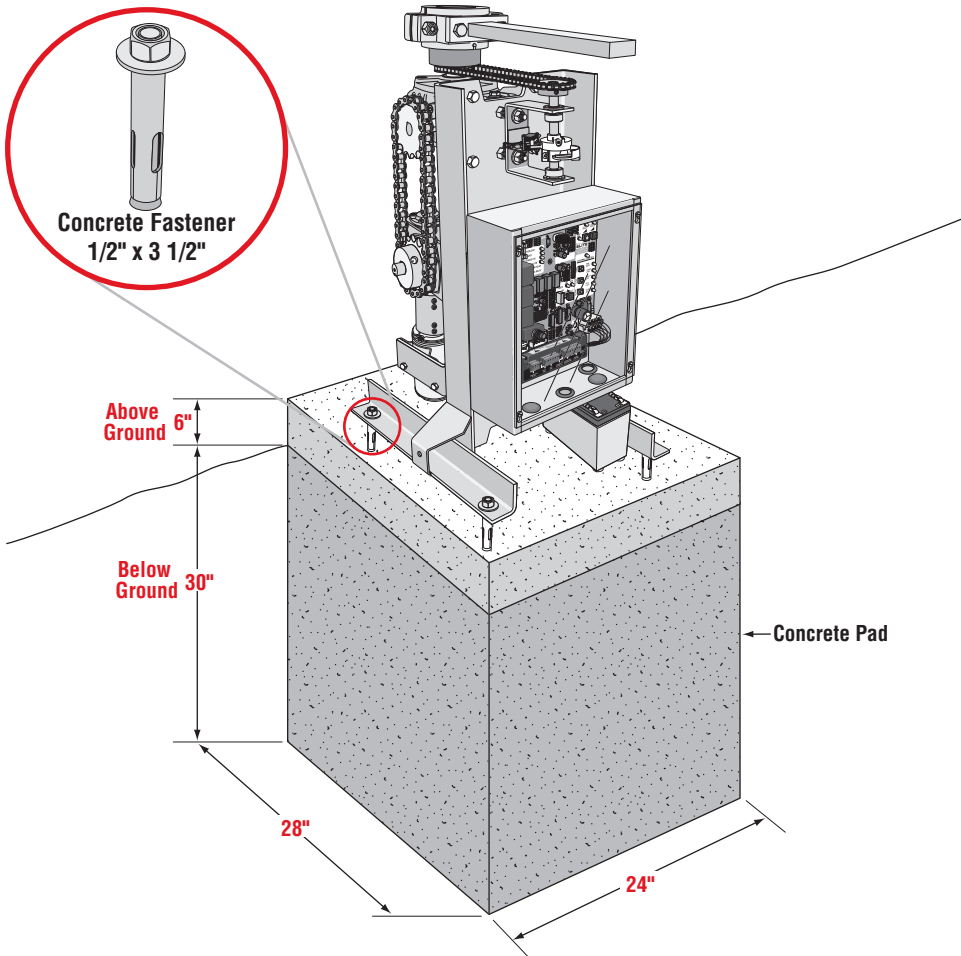

Sample Standard Installation

STANDARD INSTALLATION

Sample Standard Installation is Shown on Previous Page.

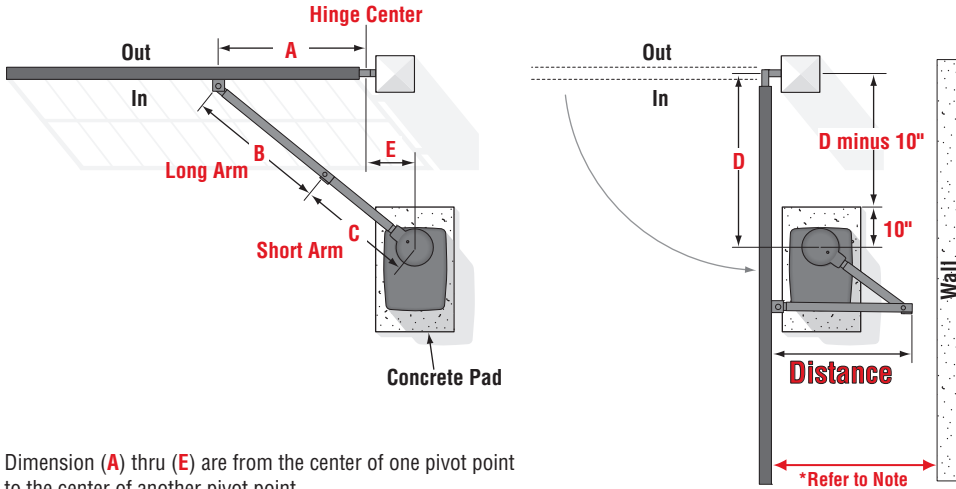

Dimension (A) thru (E) are from the center of one pivot point to the center of another pivot point.

Caution: If the gate is longer than 18 feet, follow **Chart A : A-2**.

Suggestion: The dimension between the gate and the concrete pad is always 10 inches less than the dimension D.

Example: D = 42", if the dimension between the gate and the concrete pad is 32".

Chart A						Distance
A	B	C	D	E		
1	46"	35.5"	29.5"	35"	11"	45"
2	46.75"	35.5"	33.5"	42"	11"	37"
3	46.75"	37"	31.5"	40"	11"	41"
4	47.25"	37.25"	30"	37"	11"	45"
5	47"	35"	29.5"	32"	11"	45"
6	42.5"	33"	26.5"	28.5"	11"	41"

Chart B						Distance
A	B	C	D	E		
1	34.5"	34.75"	29.5"	35"	14"	43"
2	44"	36.5"	32.5"	42"	14"	32"
3	44"	37"	30.5"	40"	14"	40"
4	45"	37"	30.5"	37"	14"	43"
5	44.75"	35.75"	29.5"	32"	14"	44"
6	41"	39"	27.5"	28.5"	14"	41"

*Note - If this dimension is between 20 and 32 inches, compact installation is necessary. (Refer to Page 11)

COMPACT INSTALLATION

Compact Installation Only!

DO NOT Use These Measurements for a Standard Installation.

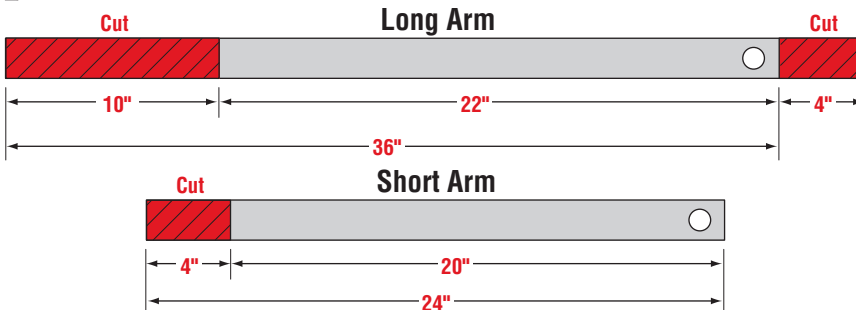
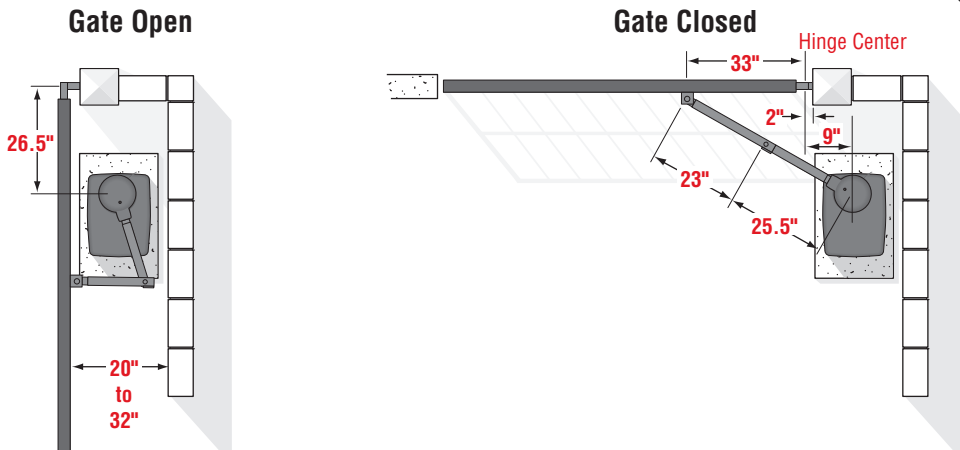
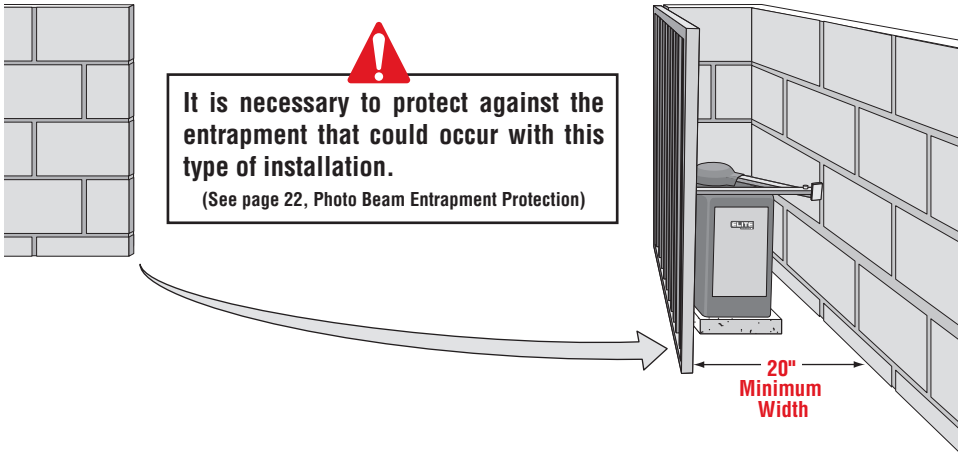

Follow the exact measurements, then cut the standard arm to meet the shorter measurements.

GATE ARM INSTALLATION

**Incorrect
Installation**

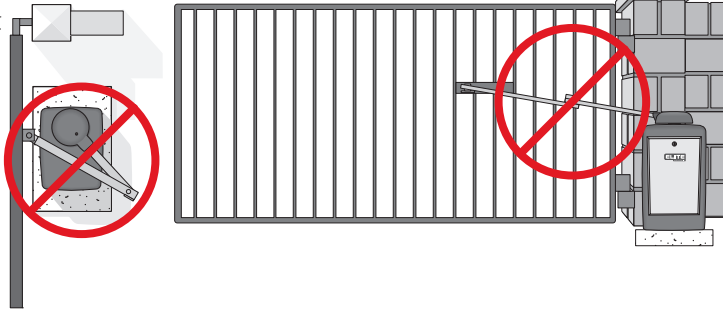

**Correct
Installation**

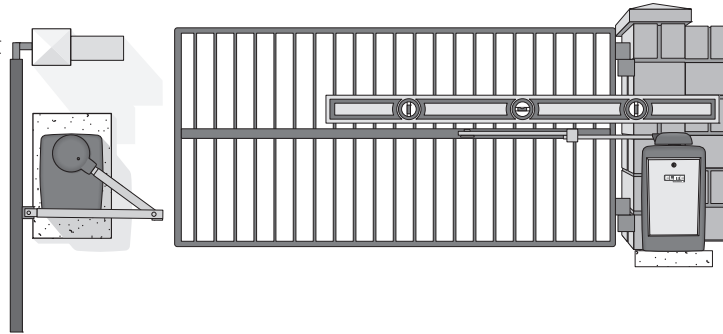

Once the gate arm measurements are calculated:

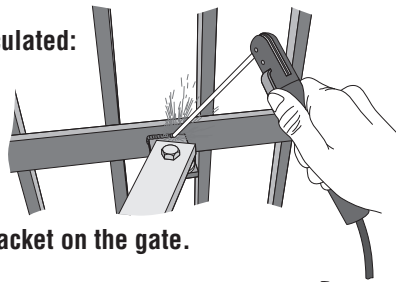

weld the bracket on the gate.

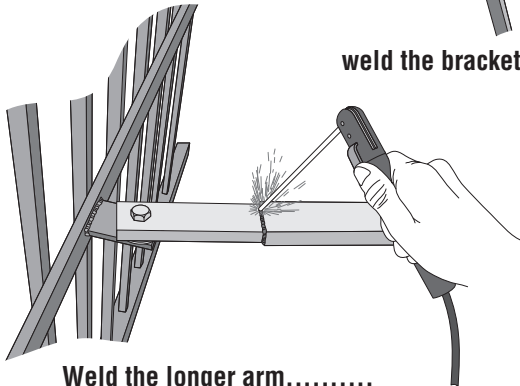

Weld the longer arm.....

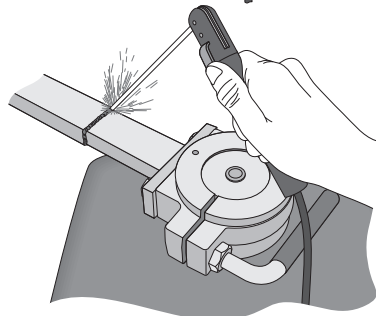

.....then weld the shorter arm.

Weld Completely Around the Rectangular Tubes

GATE MOVEMENT DIRECTION

Plug in the motor harness wires to the left (**Socket 1**) if your gate, from the inside of the property, opens to the left. Plug into the right (**Socket 2**) if the gate opens to the right.

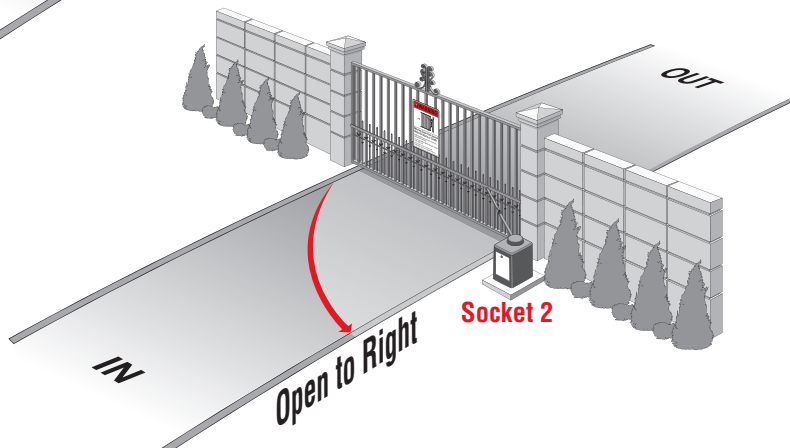
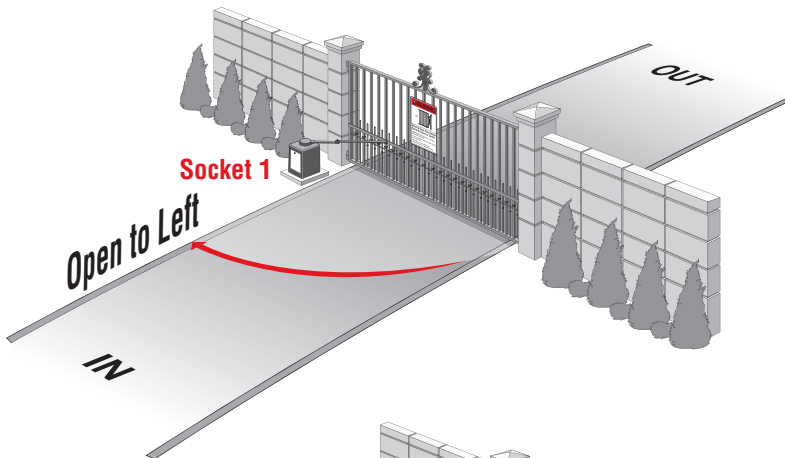
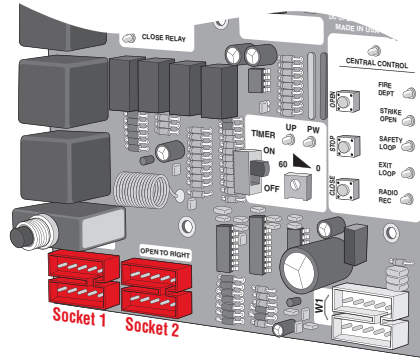

ADJUSTMENT OF OUTPUT SHAFT

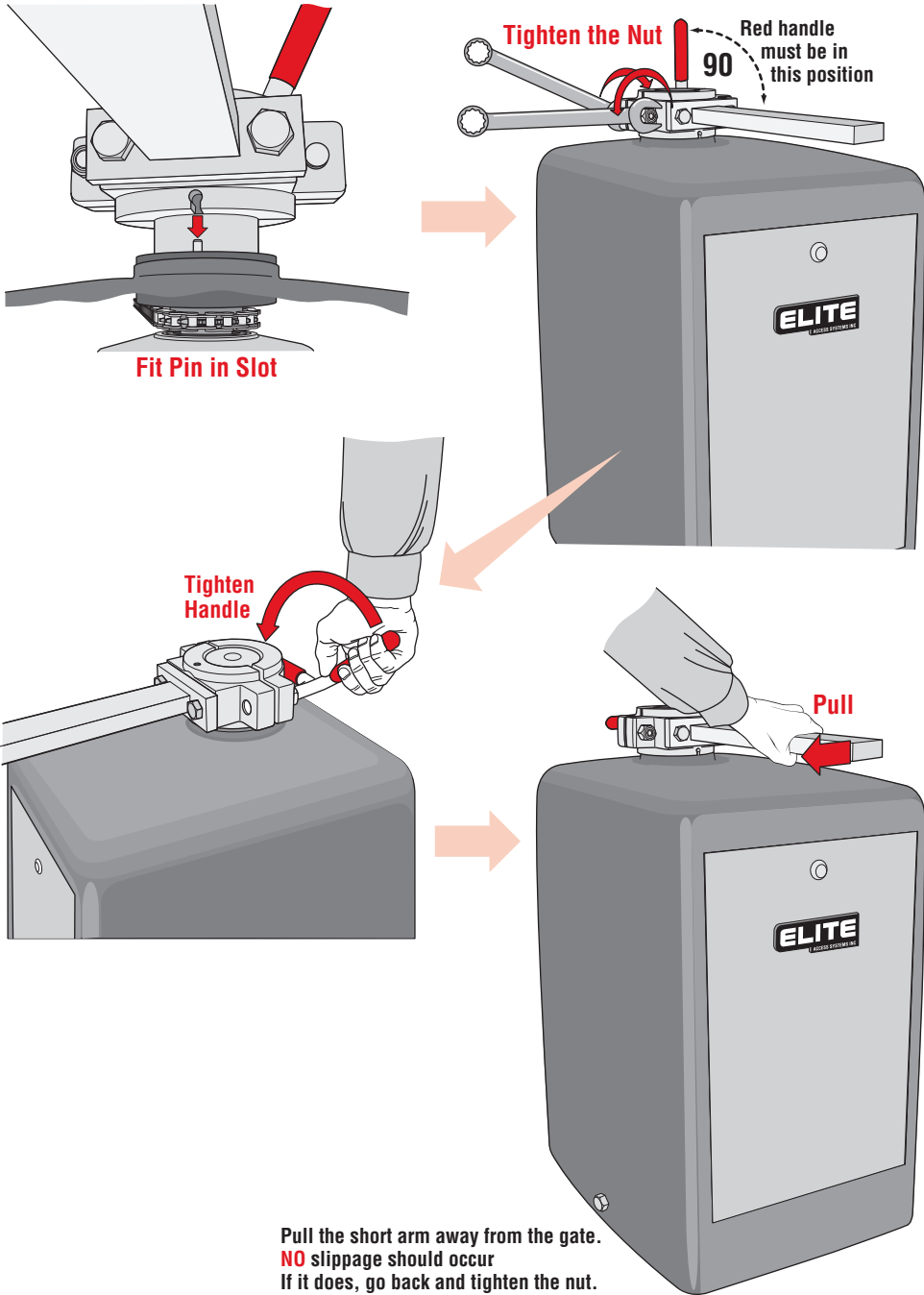

EARTH GROUND ROD INSTALLATION

An earth ground rod must be installed to protect this operator

Proper grounding gives an electrical charge, such as from an electrical static discharge or a near lightning strike, a path from which to dissipate its energy safely into the earth.

Without this path, the intense energy generated by lightning could be directed towards the Chamberlain Elite gate operator. Although nothing can absorb the tremendous power of a direct lightning strike, proper grounding can protect the gate operator in most cases.

 **Before digging more than 18" deep, contact local underground utility locating companies. Avoid damaging gas, power, or other underground utility lines.**

The earth ground rod must be located within 3 feet from the Chamberlain Elite gate operator. Use the proper type earth ground rod for your local area.

The ground wire **must** be a single, whole piece of wire. **Never** splice two wires for the ground wire. If you should cut the ground wire too short, break it, or destroy its integrity, replace it with a single wire length.

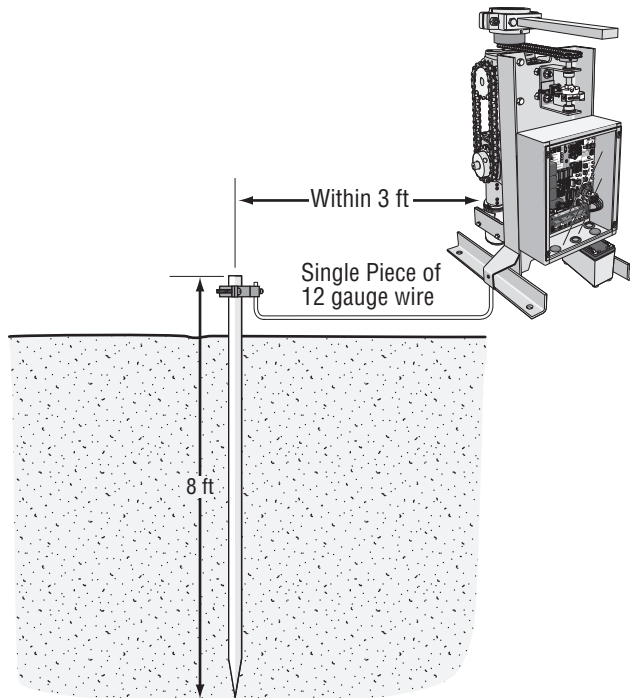

 **Chamberlain Elite Access Systems is not responsible for improper installation or failure to comply with all necessary local building codes.**

DC POWER SUPPLY CONNECTION

Use Chamberlain Elite's optional 25 Vdc plug-in transformer (Part # **A POW-1**). Hook up the transformer to 120 Vac. Use two, low voltage, 14 gauge / 300watt direct burial, landscape lighting cables. Hook these wires to the plug-in transformer and to the power input connection on the surge suppressor. Polarity does not matter.

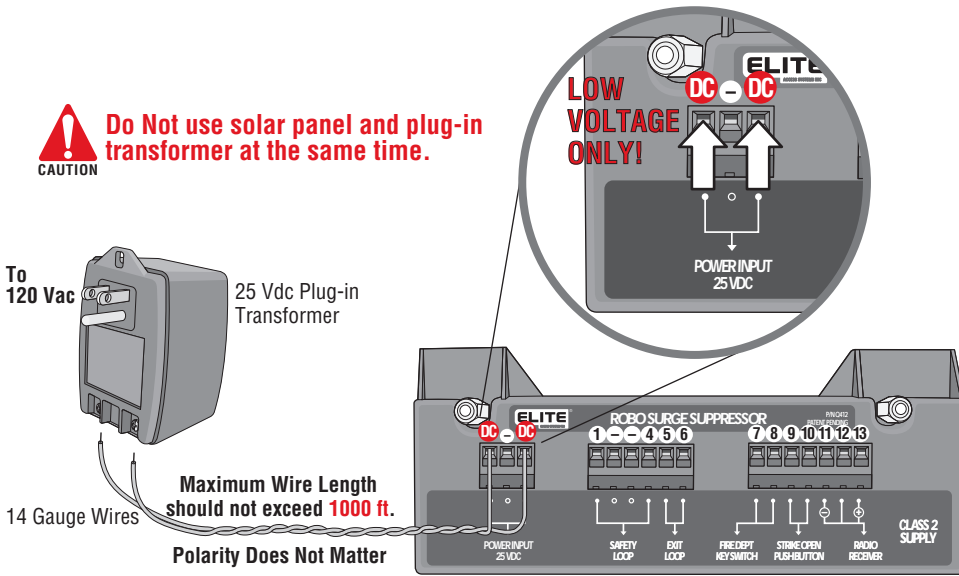

When the plug-in transformer has been connected to the power source, connect the battery cable plug to the motor harness plug. You will hear 3 beeps. After the beeps, check the “**Charge OK**” LED.....it must be “**ON**”.

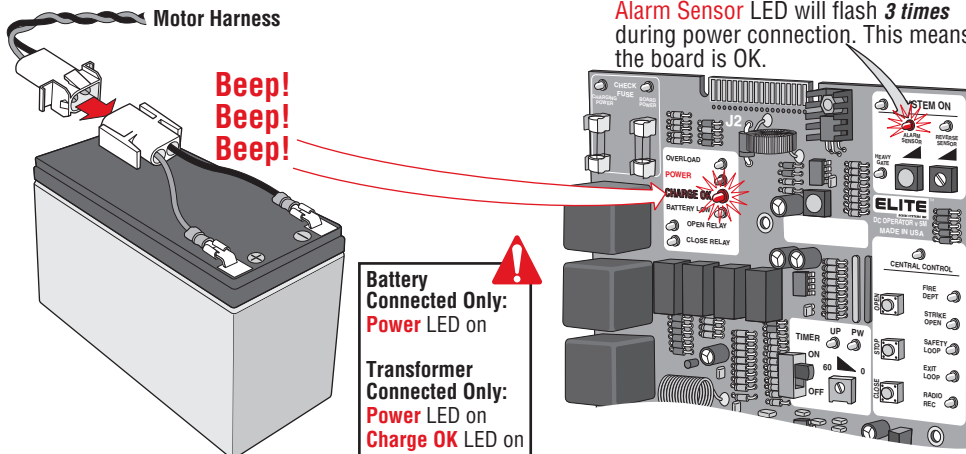

“ OPTIONAL ” SOLAR PANEL

If you use Chamberlain Elite's optional solar panel (Part # **Solar 3**). Connect the two wires from the solar panel to the power input connection on the surge suppressor (Polarity does not matter). Sunlight will energize the batteries through the solar panel. This solar panel will charge up to 1000 Mamp/Hr in optimum conditions & 300 Mamp/Hr in light overcast conditions. For further details about Chamberlain Elite's solar panel, consult the “Solar 3” Installation sheet that is included with the solar panel.

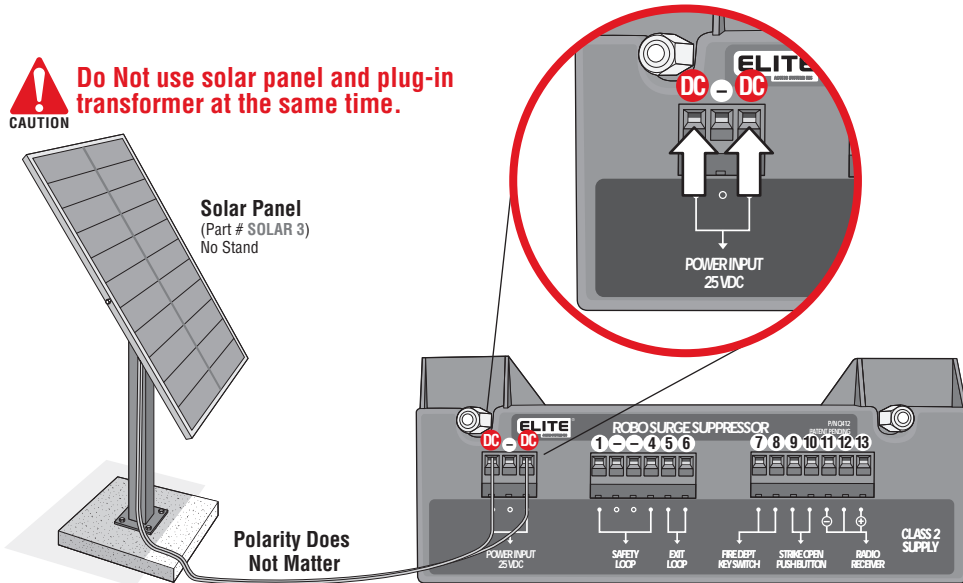

Energizing this operator with solar power only needs the radio receiver to operate the gate. The only recommended external devices other than radio receivers are dry-contact command devices which do not consume any current like key switches. **Using other devices that consume high current such as telephone access, magnetic locks or loop detectors will cause excess drainage of the battery and eventually completely drain the battery.**

CAUTION Chamberlain Elite recommends using a larger battery (**12 Vdc, 30 AHR**) (Part # **A 12330**) in this operator when using the optional solar panel.

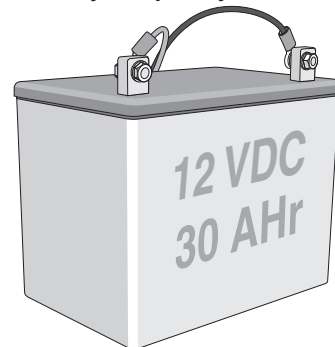

**For More Details,
contact your Local Dealer**

SURGE SUPPRESSOR TERMINAL CONNECTIONS

The radio receiver **must be 12 Vdc only** (Part # **A 1099-12V**). If you want to use safety or exit loops, you **must use 12 Vdc loop detectors only** (Part # **A 23**).

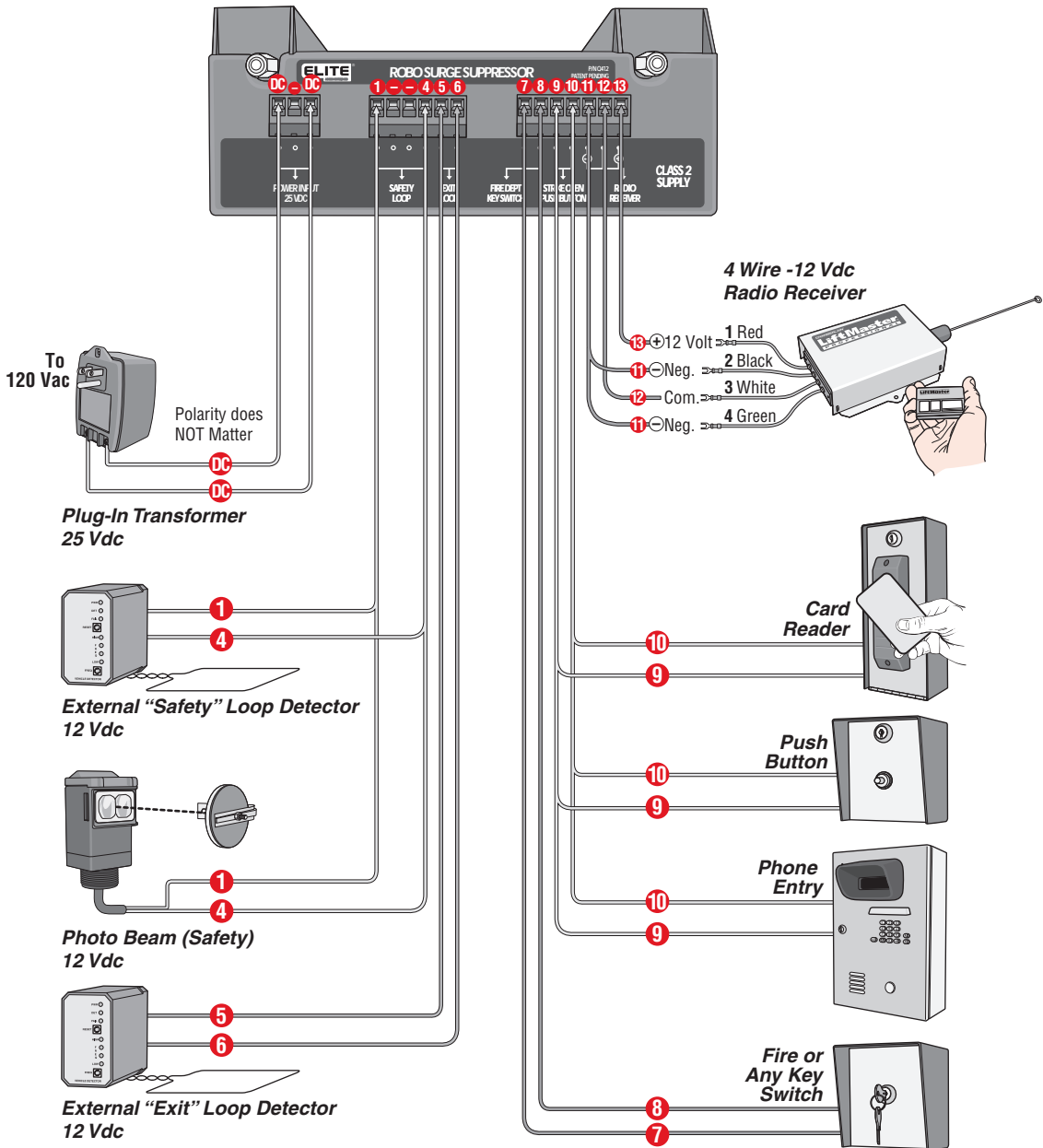

ADJUSTING GATE TRAVELING DISTANCE

Release the red handle and open the gate to a distance desired. Loosen the screw. Turn limit cam until the half moon shape hits the limit switch and you hear the switch **click**. For closing cycle, do the same with the other limit cam. For a more precise adjustment, use the set allen screw.

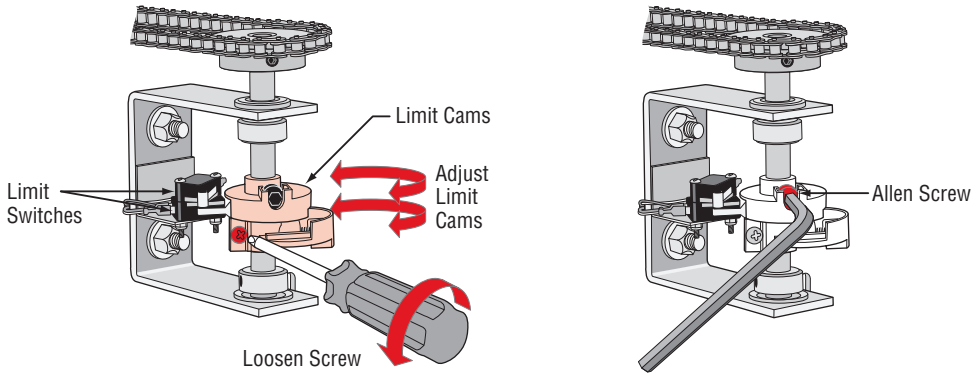

ADJUSTABLE TIMER

If you want to use the automatic close for the gate system the timer switch should be put in the **“ON”** position. If you want to use the push open or push close command, the timer should be switched to the **“OFF”** position.

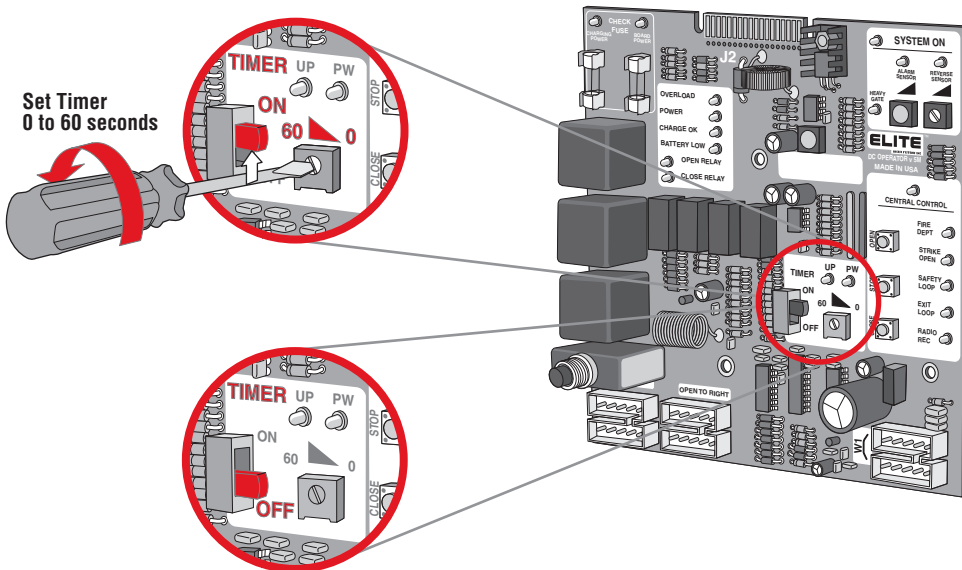

ADJUSTABLE REVERSING SENSOR

Adjust the “**Reverse Sensor**” pot on the upper portion of the control board. **Do Not Touch Alarm Sensor pot.**

The level of reverse sensitivity depends on the weight of the gate and the condition of installation.

Too sensitive = if the gate stops or reverses by itself.

Not sensitive enough = if the gate hits an object and does not stop or reverse.



Do Not Touch Alarm Sensor Pot

Minimum Sensitivity

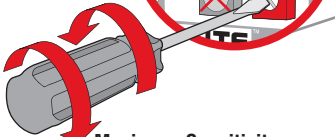

Maximum Sensitivity

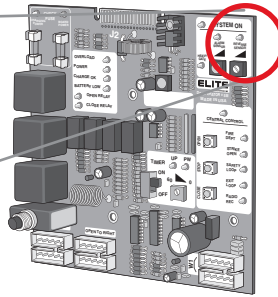

Important Note!

There is a “**Heavy Gate**” LED which will light up when the gate is heavier than normal. This is a diagnostic LED and the operator will still function normally when this indicator is on.

WARNING PLACARD PLACEMENT

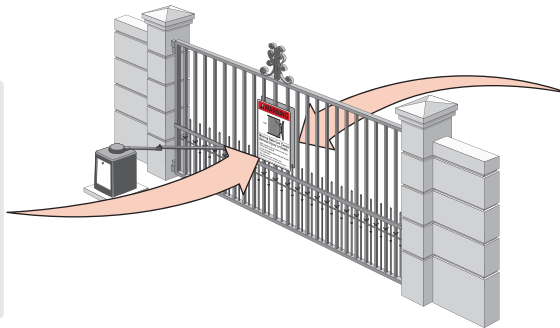

Warning placards need to be permanently mounted on **BOTH** sides of the gate.

EMERGENCY RELEASE

- 1 Unscrew Bolt**
Special tool required for the "optional" security bolt

- 2 Lift Off Cover**

- 3 Loosen Red Handle**
Gate can now be manually moved

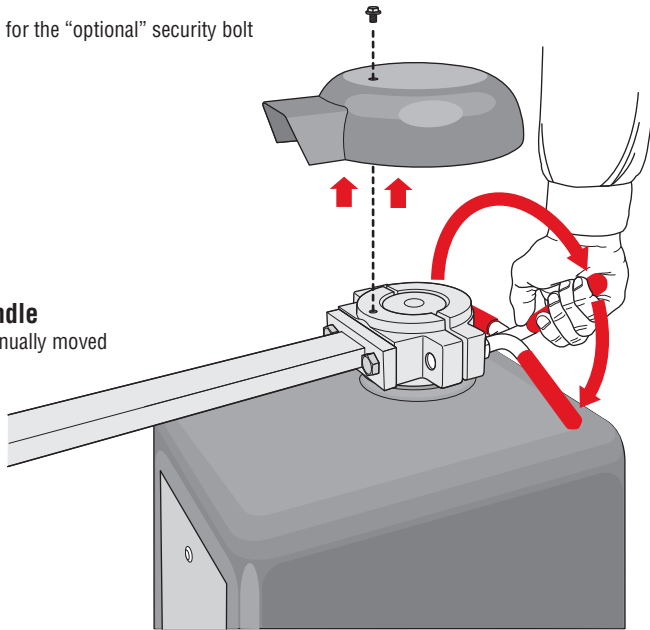

Grab the Gate to Make Adjustments

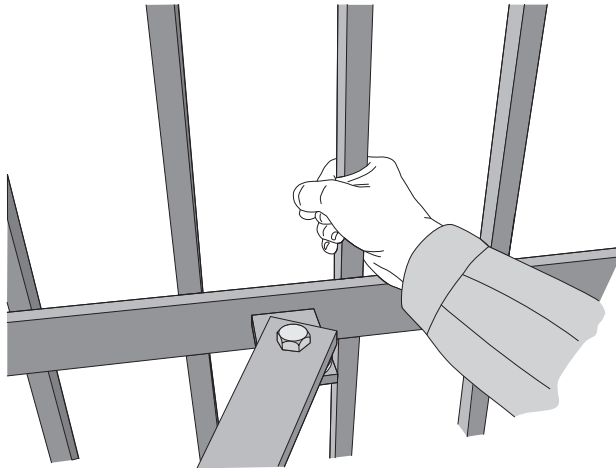

Tighten the Red Handle, Replace the Cover and Bolt when Finished

When the power is turned on again, the gate will readjust itself automatically.

SAFETY DEVICE WIRING

Sensing Edges

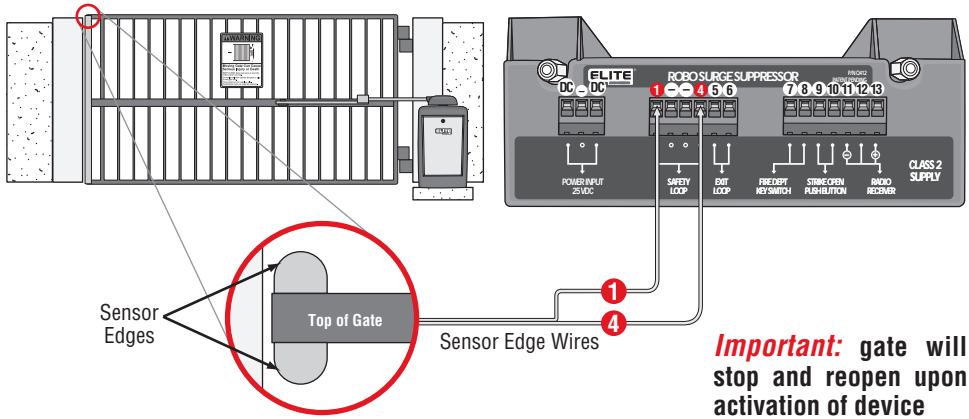
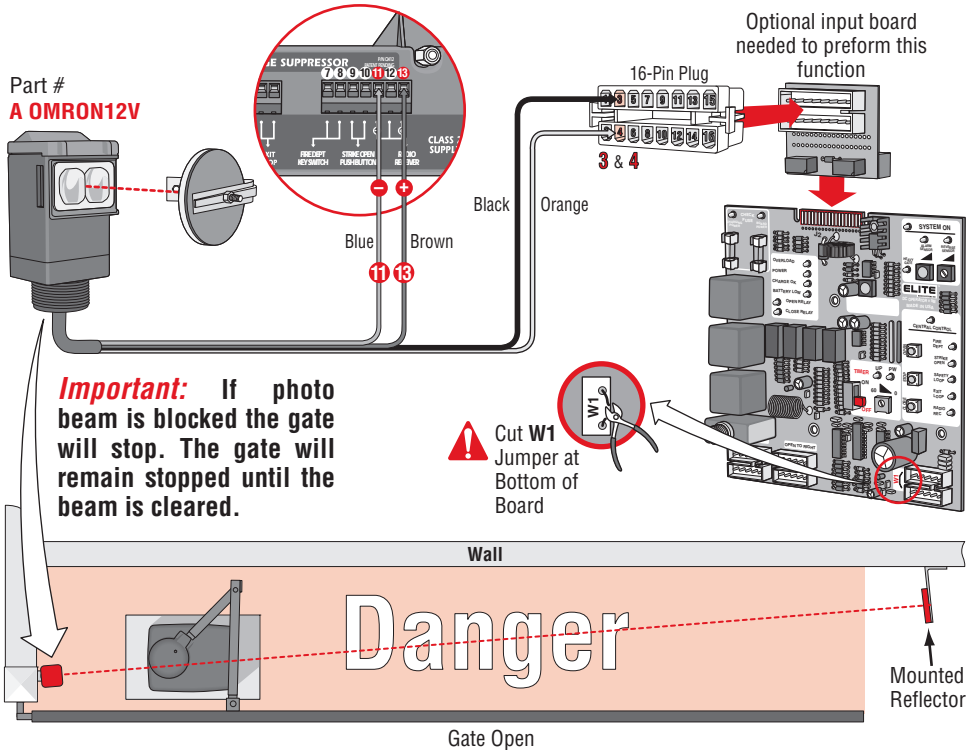

Photo Beam Entrapment Protection



“ O P T I O N A L ” I N P U T B O A R D

The optional board allows extra control of the gate, is available only from Chamberlain Elite Access Systems. Installation is simple; just clip the optional board to the **J2** slot on the top of the control board. Below lists the function of each pin.

- 1 & 2** Open Switch (N.O.)
- 3 & 4** Stop Switch (N.C.) (Cut **W1** Jumper at Bottom of Board)
- 5 & 6** Timer Close Output to Slave
- 7 & 8** Timer Input from Master (Close Command or Close Switch) (N.O.)
- 9 & 10** Alarm Output will be set off with very heavy gates or object preventing gate operation. (Not Burglar Alarm) (9 = +12 Vdc, 10 = Alarm)
- 11 & 4** Emergency Open Switch (Direct Command from Battery to Motor)
- 12 & 7** Emergency Close Switch (Direct Command from Battery to Motor)
- 13 & 14** Magnetic Lock - Dry Contact Relay (13 = Com, 14 = N.C.)
- 15 & 16** Center Loop Option (For Swing Gate Operators Only)

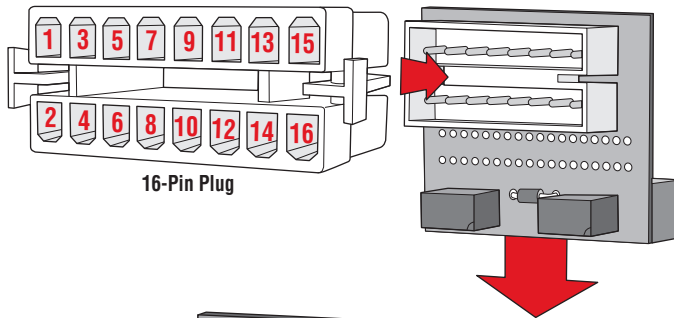

16-Pin Plug

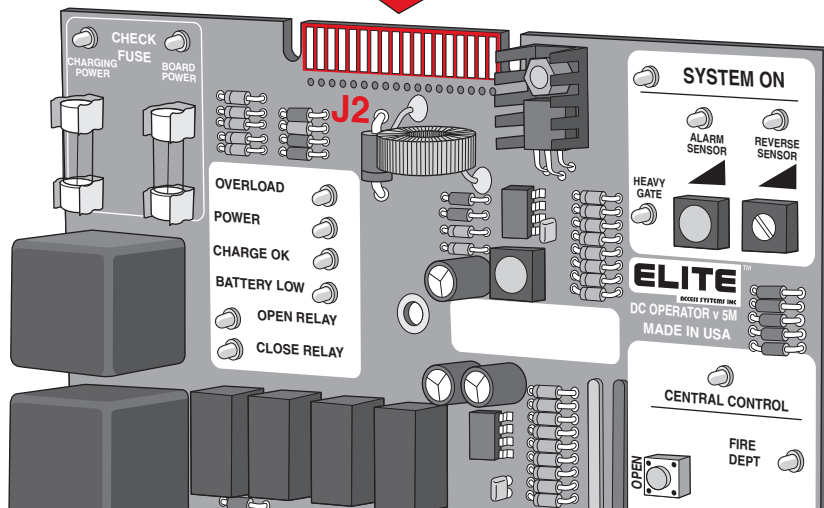

MAGLOCK WIRING CONNECTION

The "Optional" input board **MUST** be used to perform this function. (Part# **Q203**)

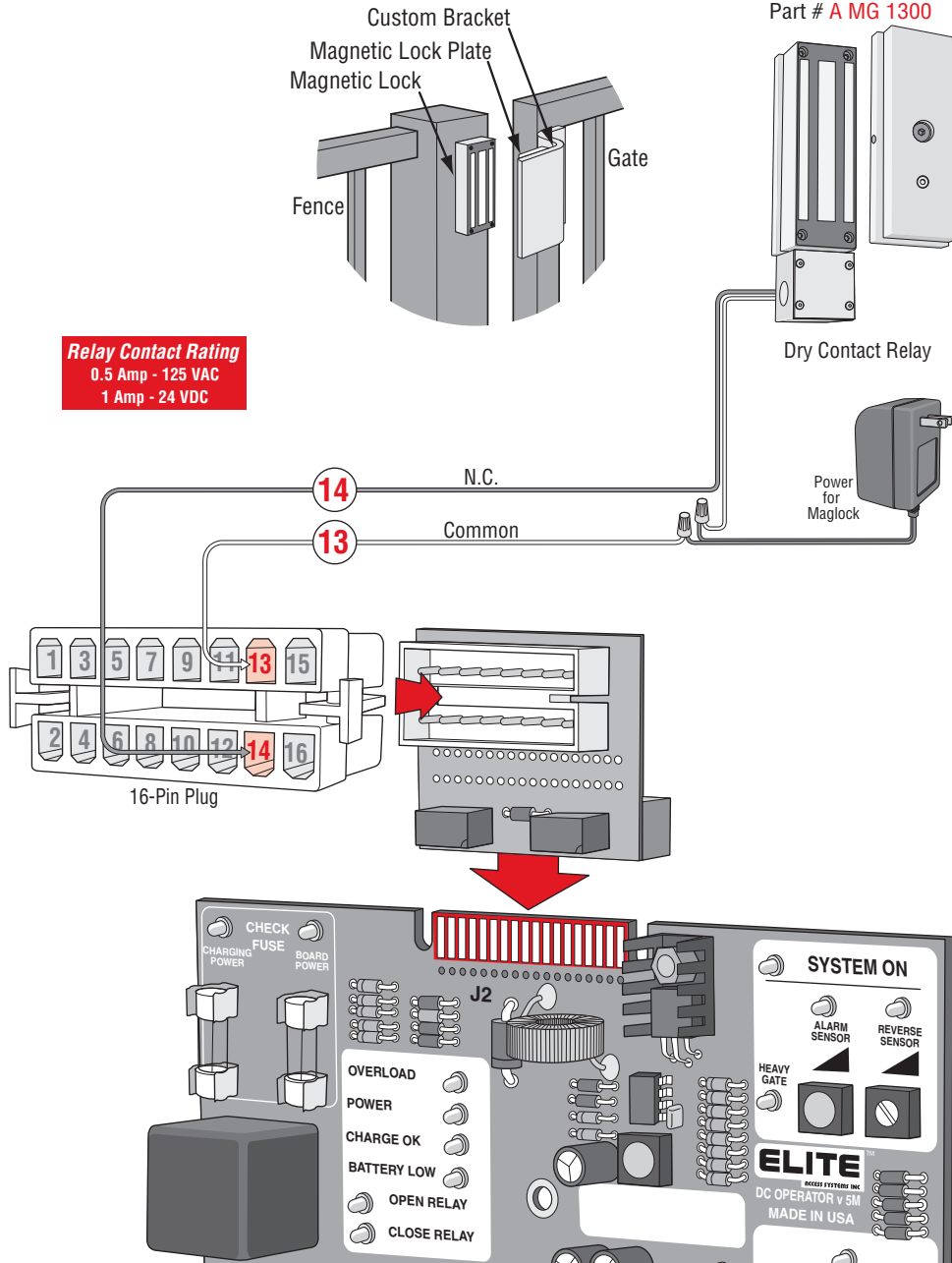

Relay Contact Rating
 0.5 Amp - 125 VAC
 1 Amp - 24 VDC

OPTIONAL 12 VDC PHOTO BEAM SAFETY WIRING

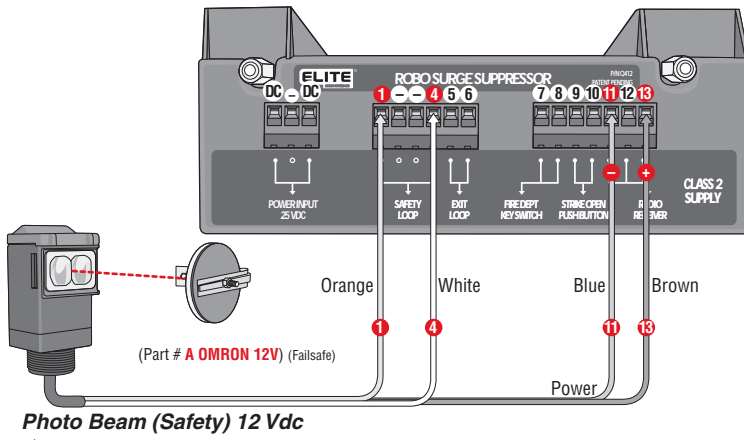

It is best to use 12 Vdc Failsafe Photo Beam Sensors for this Safety Option

Failsafe Photo Beam: If a failsafe photo beam is not working or loses power or photo beam is blocked, then the photo beam will stop **all** gate operation.

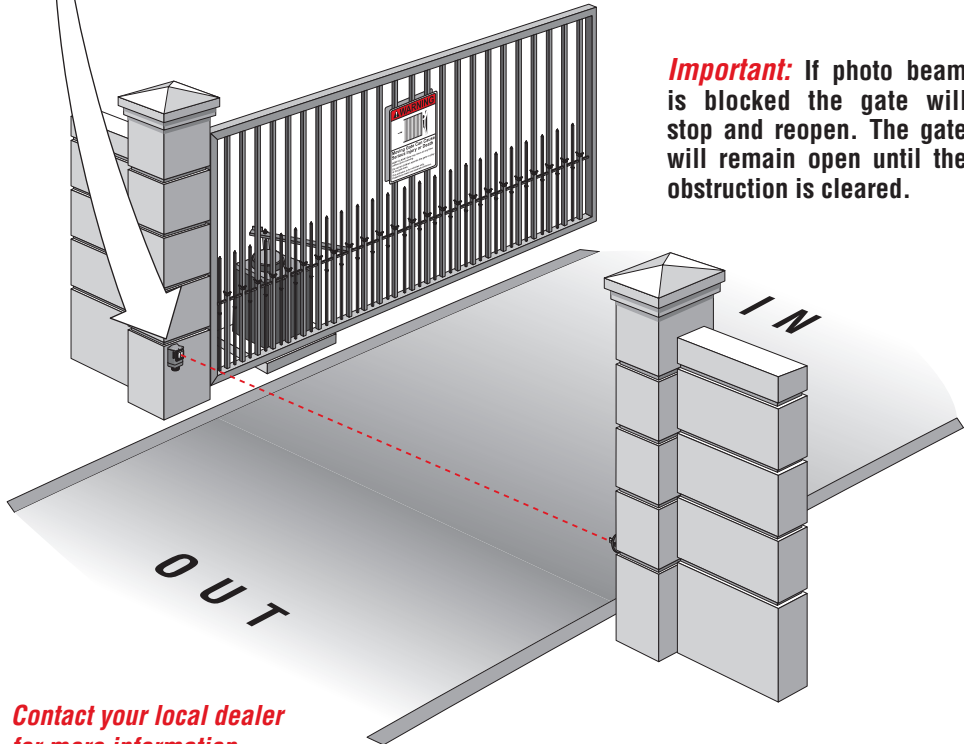

Important: If photo beam is blocked the gate will stop and reopen. The gate will remain open until the obstruction is cleared.

Contact your local dealer for more information.

3 - PUSH BUTTON WIRING CONNECTION

The “Optional” input board **MUST** be used to perform this function. (Part# **Q203**)

There can be **NO** common wires within this 3-push button station.

Open-N.O. Contact
 Stop-N.C. Contact
 Close-N.O. Contact

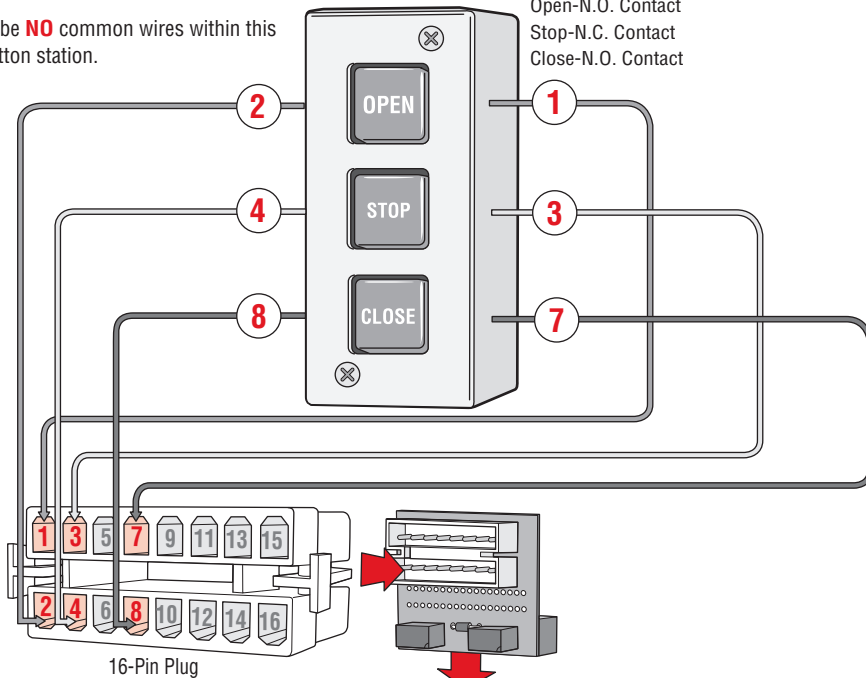

16-Pin Plug

 Cut **W1** jumper at the bottom of Board to use the stop button in the 3-push button station

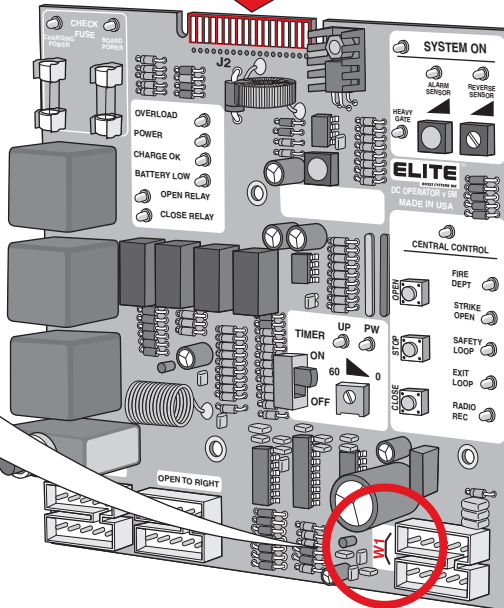
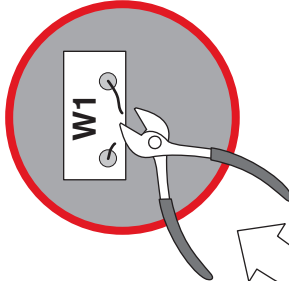

3 - PUSH BUTTON WIRING MASTER / SECOND

The "Optional" input board **MUST** be used on both operators to perform this function (Part# **Q203**). A 12 Vdc Double Pull Double Throw (DPDT) 3 Amp Minimum Relay must be used (Not Included).

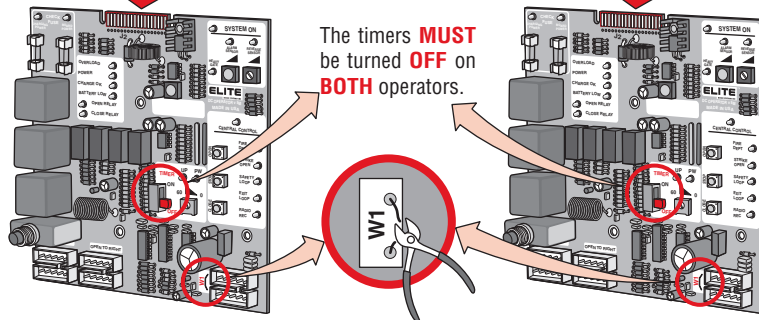
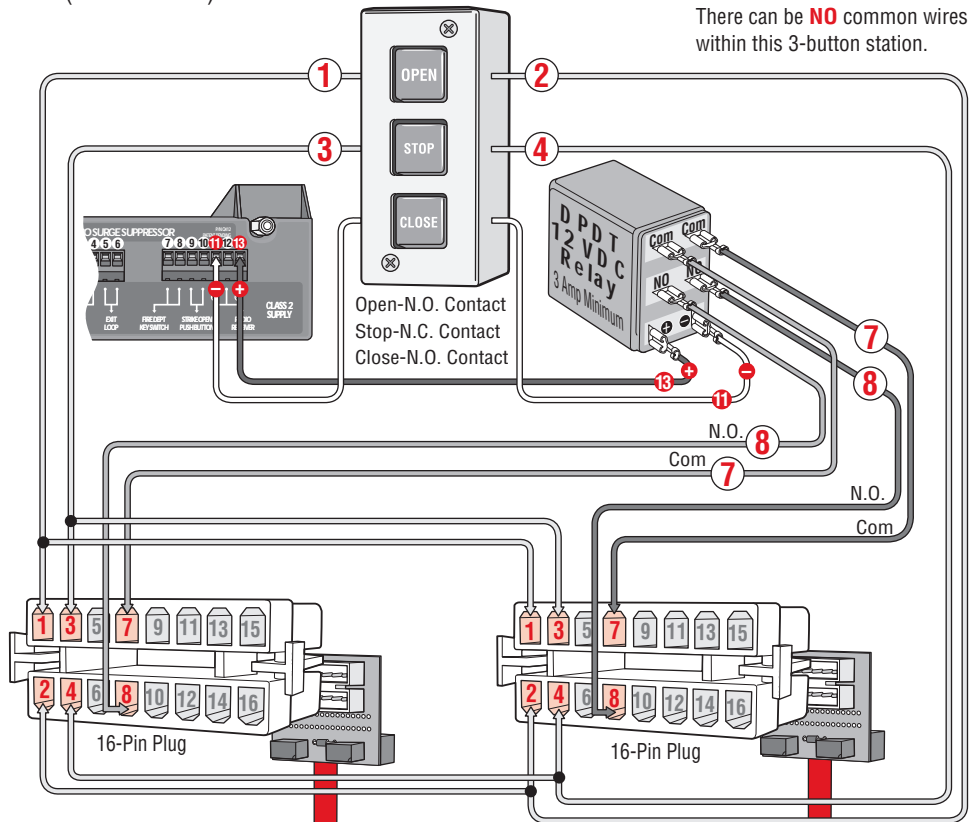

! Cut W1 jumper at the bottom of each board to use the stop button in the 3-push button station

SINGLE OPERATOR LOOP SIZE AND PLACEMENT

It is **VERY** important to have enough separation between loops and gates to prevent false detection.

⚠ Caution: Distance "E" must be a minimum of 4 feet away from open gate!

Maximum gate length for Robo Swing is 16 Feet.

Drawing not to scale

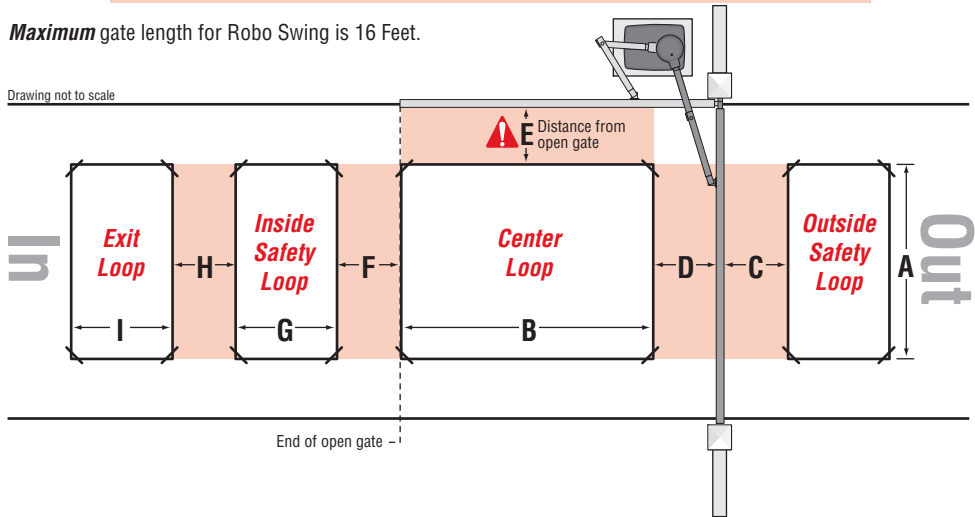

Outside Safety Loop:

If A =	6 Feet	9 Feet	12 Feet	15 Feet	18 Feet	21 Feet
Then C =	4 Feet	4.5 Feet	5 Feet	5 Feet	5.5 Feet	6 Feet

Center Loop:

This loop must have enough space between loop and gate when **opened** or **closed**.

If driveway is **smaller** than 18 ft, then **D** must be ≥ 4.5 ft

If driveway is **bigger** than 18 ft, then **D** must be ≥ 5 ft

If B =	6 Feet	9 Feet	12 Feet	15 Feet
Then E =	4 Feet	4.5 Feet	5 Feet	5 Feet

Inside Safety Loop

If there is **no** center loop, then **F** ≥ 4 ft

If there is a center loop, then **F = B** or **G** which ever is largest.

Exit Loop

H = G or **I** which ever is largest.

This is for a typical single operator loop installation. Individual circumstances may alter dimensions.

MASTER/SECOND LOOP SIZE AND PLACEMENT

It is **VERY** important to have enough separation between loops and gates to prevent false detection.

⚠ Caution: Distance "E" must be a minimum of 4 feet away from open gate!

Maximum gate length for each Robo Swing is 16 Feet.

Drawing not to scale

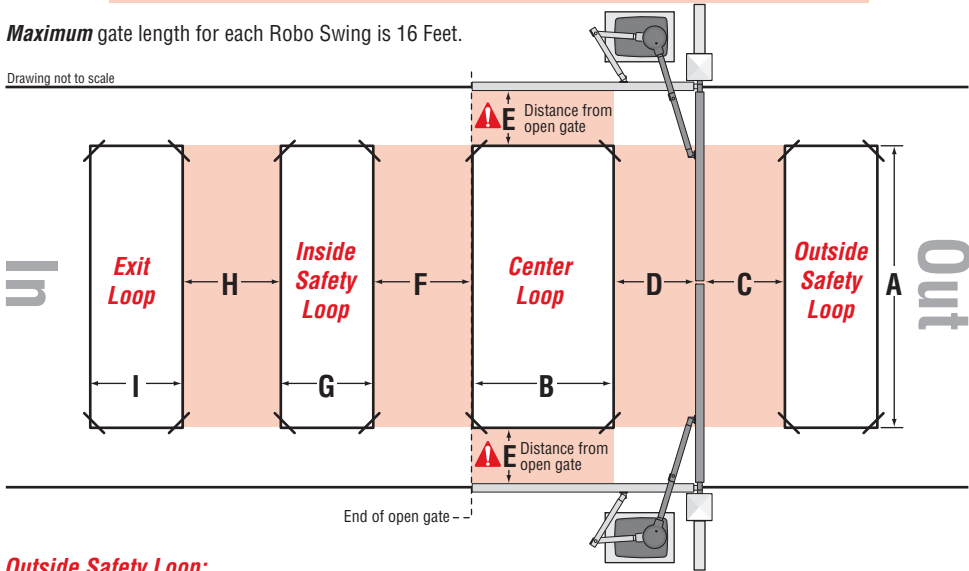

Outside Safety Loop:

If A =	6 Feet	9 Feet	12 Feet	15 Feet	18 Feet	21 Feet
Then C =	4 Feet	4.5 Feet	5 Feet	5 Feet	5.5 Feet	6 Feet

Center Loop:

This loop must have enough space between loop and gate when **opened** or **closed**.

If driveway is **smaller** than 18 ft, then **D** must be ≥ 4.5 ft

If driveway is **bigger** than 18 ft, then **D** must be ≥ 5 ft

If B =	6 Feet	9 Feet	12 Feet	15 Feet
Then E =	4 Feet	4.5 Feet	5 Feet	5 Feet

Inside Safety Loop

If there is **no** center loop, then **F** ≥ 4 ft

If there is a center loop, then **F = B** or **G** which ever is largest.

Exit Loop

H = G or **I** which ever is largest.

This is for a typical master/slave loop installation. Individual circumstances may alter dimensions.

LOOP INSTALLATION AND NUMBER OF WIRE TURNS

Loop Installation “Saw Cut” Type

- 1 Mark the loop layout on the pavement. Remove sharp inside corners that can damage the loop wire insulation.
- 2 Set the saw to cut to a depth (typically 2" to 2.5") that insures a minimum of 1" from the top of the wire to pavement surface. The saw cut width should be larger than the wire diameter to avoid damage to the wire insulation when placed in the saw slot. Cut the loop and feeder slots. Remove all debris from the slot with compressed air. Check that the bottom of the slot is even.
- 3 It is highly recommended that a continuous length of wire be used to form the loop and feeder to the detector. It is also highly recommend using 12-18 AWG cross-link polyethylene (XLPE) insulation for the loop wire. Use heavier wire gauge for a more durable loop area. Use a wood stick or roller to insert the wire to the bottom of the saw cut (Do not use sharp objects). Wrap the wire in the loop saw cut until the desired number of turns is reached. Each turn of wire must lay flat on top of the previous turn.
- 4 The wire must be twisted together a minimum of 6 twists per foot from the end of the saw cut to the detector.
- 5 The wire must be held firmly in the slot with 1" pieces of backer rod every 1 to 2 feet. This prevents the wire from floating when the loop sealant is applied.
- 6 Apply the sealant. The sealant selected should have good adhering properties with similar expansion and contraction characteristics to that of the pavement material.

Number of Wire Turns Needed for Loop

! Important

Loop Perimeter	Number of Wire Turns
10 feet to 13 feet	4
14 feet to 26 feet	3
27 feet to 80 feet	2
80 feet and up	1

! The wire *must* be twisted together 6 twists per foot from the end of the saw cut to the loop detector.

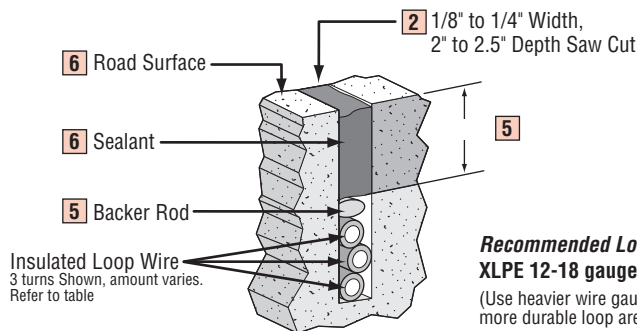
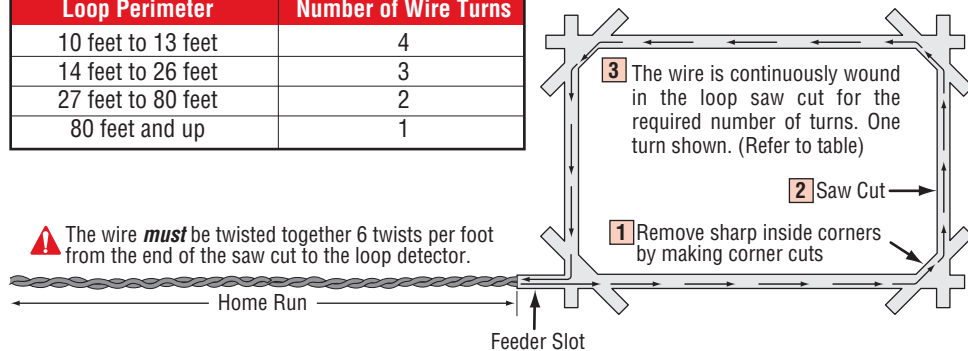

Recommended Loop Wire
XLPE 12-18 gauge
 (Use heavier wire gauge for a more durable loop area)

WIRING LOOP DETECTOR TO OPERATOR

Velcro external loop detectors in place

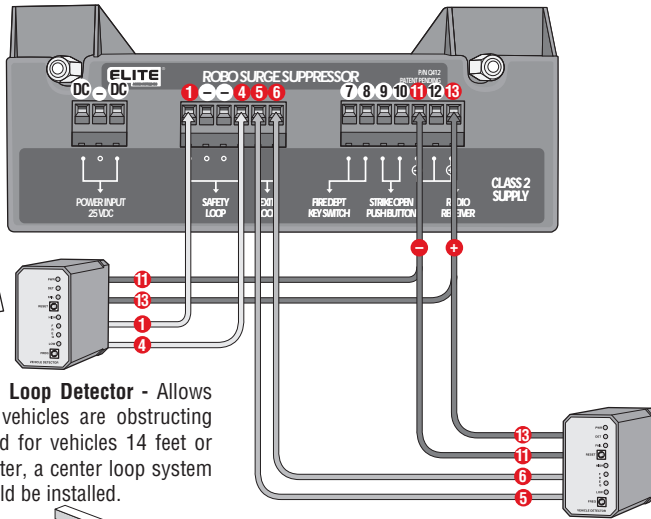
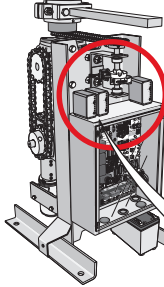

External 12 Vdc “Safety” Loop Detector - Allows gate to stay open when vehicles are obstructing path. **CAUTION:** Suggested for vehicles 14 feet or longer. If a vehicle is shorter, a center loop system is recommended and should be installed.

External 12 Vdc “Exit” Loop Detector - Allows gate to automatically open for exiting vehicles.

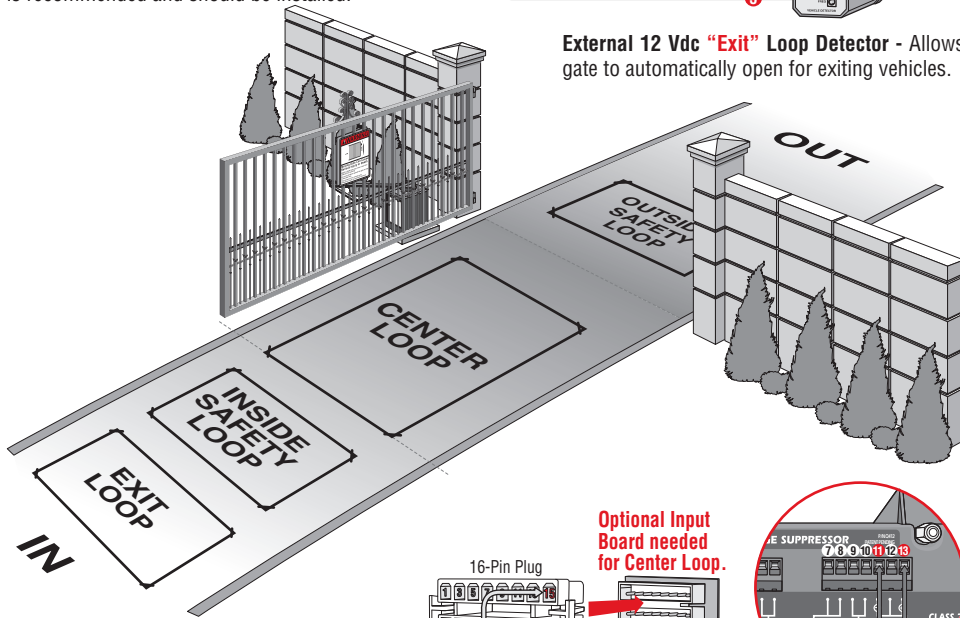

Optional Input Board needed for Center Loop.

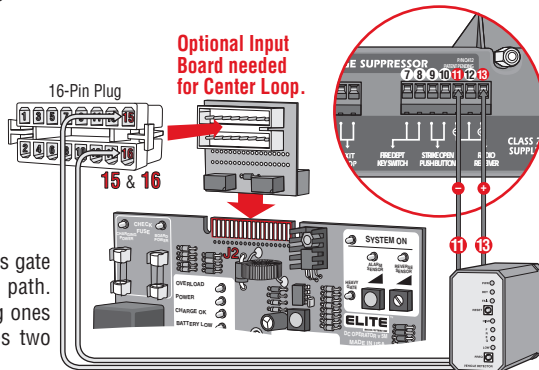

External 12 Vdc “Center” Loop Detector - Allows gate to stay open when vehicles are obstructing path. **CAUTION:** This option is for all vehicles including ones less than 14' long. Center loop system requires two safety loops

MASTER AND SECOND WITH TIMER

To use the master/second option with Robo Swing, you must purchase the **Optional Input Board** (Part # **Q203**) and connect it to the **J2** slot of each board. (Refer to page 23)

Caution: 25 Vdc plug-in transformer per gate operator required

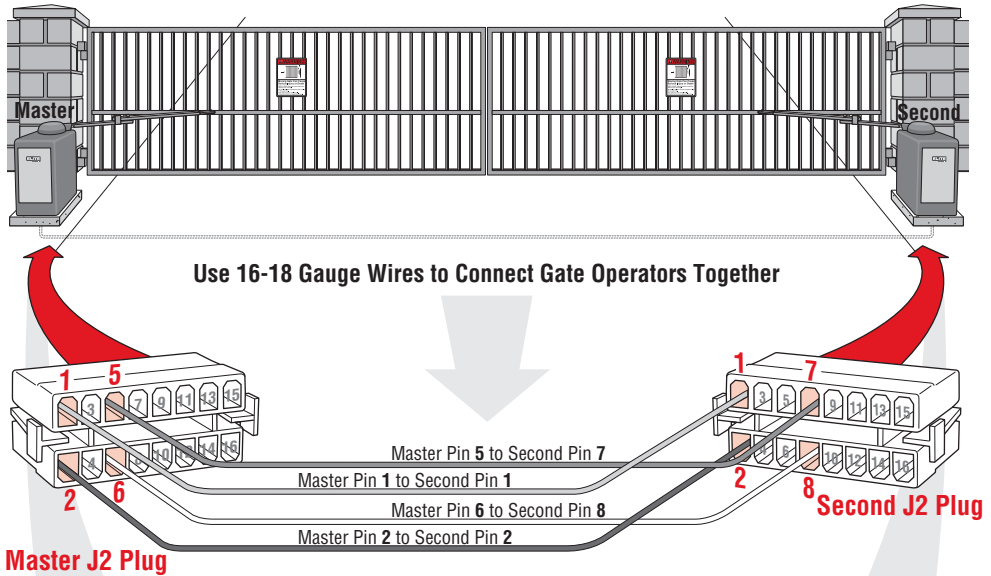

1. Make master/second J2 plug connections as shown above
2. Turn timers on **BOTH** control boards to the "ON" position
3. Use **MASTER** timer **ONLY** for the auto close time adjustment (0 to 60 sec)
4. Turn the **SECOND** timer adjustment all the way Counterclockwise

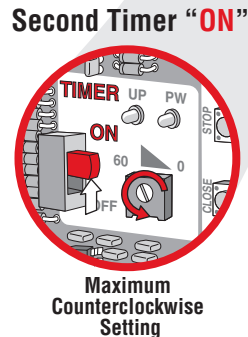
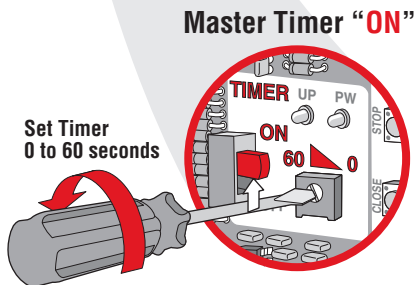

MASTER AND SECOND WITHOUT TIMER

To use the master/second option with Robo Swing, you must purchase the **Optional Input Board** (Part # **Q203**) and connect it to the **J2** slot of each board. (Refer to page 23)

Caution: 25 Vdc plug-in transformer, per gate operator required

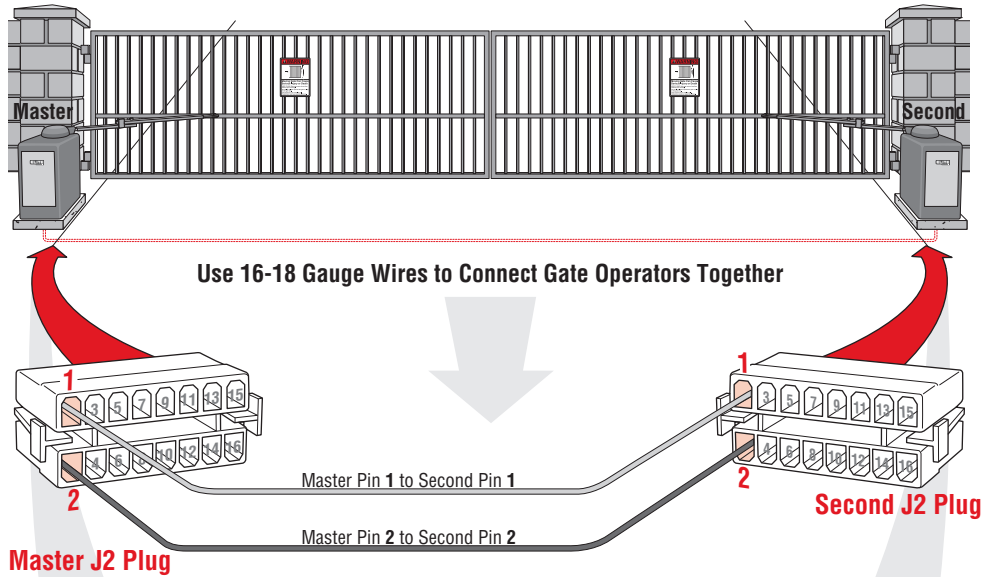

1. Make master/second J2 plug connections as shown above
2. Turn timers on **BOTH** control boards to the “OFF” position

Master Timer “OFF”

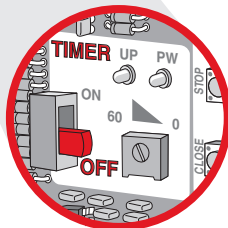

Second Timer “OFF”

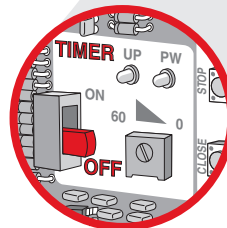

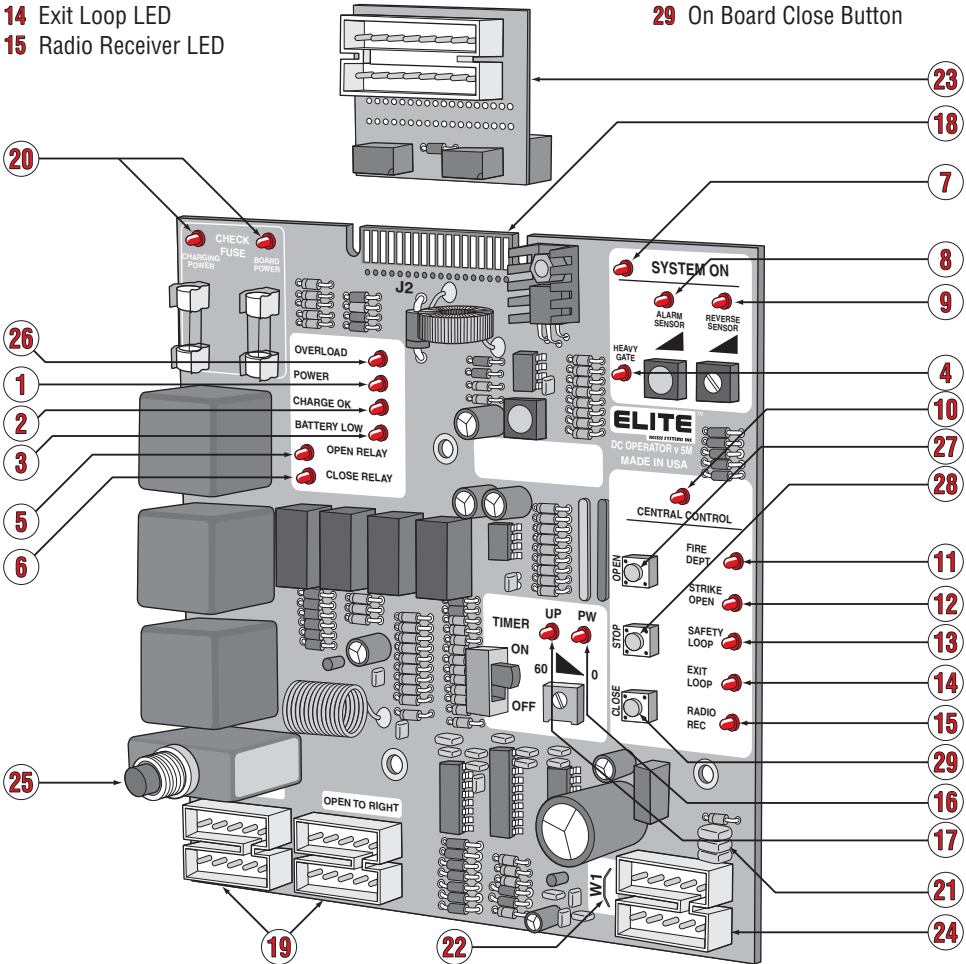

CONTROL BOARD FUNCTIONS

- | | |
|---|--|
| 1 Power On LED | 16 Timer Power LED |
| 2 Charge On LED | 17 Timer-Up Indicator |
| 3 Low Battery Indicator LED | 18 J2 Alternate Optional Output |
| 4 Heavy Gate Indicator LED | 19 Movement Direction Sockets |
| 5 Open Relay LED | 20 Replace Fuse Indicator |
| 6 Close Relay LED | 21 Spike Suppressor |
| 7 System on, Reversing Sensor and Alarm Sensor | 22 Jumper for Stop Button |
| 8 Alarm Sensor LED | 23 Optional Input Board |
| 9 Reversing Sensor LED (Rebounder) | 24 Surge Suppressor Connector |
| 10 Central Control LED | 25 Breaker Reset |
| 11 Fire Department or Key Switch LED | 26 Overload LED |
| 12 Strike Open LED | 27 On Board Open Button |
| 13 Safety Loop or Photocell LED | 28 On Board Stop Button |
| 14 Exit Loop LED | 29 On Board Close Button |
| 15 Radio Receiver LED | |





CONTROL BOARD LED DESCRIPTION

<i>LED Description</i>	 LED On	 LED Off
<p>1 Power at all times when there is one or more power sources ie: Battery, 25 Vdc or solar</p>	Power source OK and board power fuse OK	<p>1. No power source at all</p> <p><i>If dimmed down</i></p> <p>1. Bad board power fuse</p>
<p>2 Charger OK on when there is any charging power ie: 25 Vdc - solar</p>	Transformer or solar OK and charging power fuse OK	<p>1. No Transformer or Solar</p> <p><i>If dimmed down</i></p> <p>1. Bad charging power fuse</p>
<p>3 Battery Low normally off - it will indicate low battery</p>	<p><i>Flashing LED - Battery is less than required limit needs to be recharged</i></p> <ol style="list-style-type: none"> 1. Excess usage 2. Bad charging system 3. Under rate solar panel 4. Bad battery 5. Bad battery connection 	<p>Battery OK Battery voltage is over minimum required limit</p>
<p>4 Heavy Gate will work only when the gate is in motion</p>	<ol style="list-style-type: none"> 1. Gate is too heavy 2. Bad wheels 3. Bad rollers 4. Chain is too tight 5. Steep slope on open or close cycle 6. Low battery 	<p>Gate weight and condition are OK</p>
<p>5 Open Relay</p>	Open relay is energized	Open relay is not energized
<p>6 Close Relay</p>	Close relay is energized	Close relay is not energized
<p>7 System On will work only when the gate is in motion</p>	Detecting motor current	<ol style="list-style-type: none"> 1. Motor stop 2. No motor current detected
<p>8 Alarm Sensor when LED goes on you will hear a “beep” sound for about 20 seconds.</p> <hr/> <p>LED will flash 3 times for “board OK” during power connection.</p>	<ol style="list-style-type: none"> 1. Hearing beep sound means overload 2. Gate is too heavy 3. Broken wheel 4. Gate off track 5. Unwanted object has physically stopped gate 	<p>System is OK</p>

Note: Circled red numbers indicates location on control board, identified on page 34.

CONTROL BOARD LED DESCRIPTION

<i>LED Description</i>	 LED On	 LED Off
9 Reversing Sensor	Sensor is detecting obstruction	No obstruction is detected
10 Central Control	Acknowledgement of receiving open command from one of the surge suppressor terminals <ul style="list-style-type: none"> • Fire Department 7 & 8 • Strike Open 9 & 10 • Safety Loop 1 & 4 • Exit Loop 5 & 6 • Radio Receiver 11 & 12 	Not receiving any command
11 Fire Dept	Receiving signal at the surge suppressor terminal block 7 & 8	Not receiving signal at the surge suppressor terminal block 7 & 8
12 Strike Open	Receiving signal at the surge suppressor terminal block 9 & 10	Not receiving signal at the surge suppressor terminal block 9 & 10
13 Safety Loop	Receiving signal at the surge suppressor terminal block 1 & 4	Not receiving signal at the surge suppressor terminal block 1 & 4
14 Exit Loop	Receiving signal at the surge suppressor terminal block 5 & 6	Not receiving signal at the surge suppressor terminal block 5 & 6
15 Radio Rec	Receiving signal at the surge suppressor terminal block 11 & 12	Not receiving signal at the surge suppressor terminal block 11 & 12
16 Timer PW	Timer power is on	Timer is not on
17 Timer UP	Output signal to close relay	Not receiving signal to close relay

Note: Circled red numbers indicates location on control board, identified on page 34.

TROUBLESHOOTING

How to Reset the Breaker

If all electronic sensors fail or are not adjusted properly due to heavy gates, off-track gate, or obstructed gate path, the breaker will kick-out. Reset the breaker by pressing the reset button located on the bottom left corner of the control board.



Always disconnect the battery before resetting the breaker or injury could occur as the gate starts.

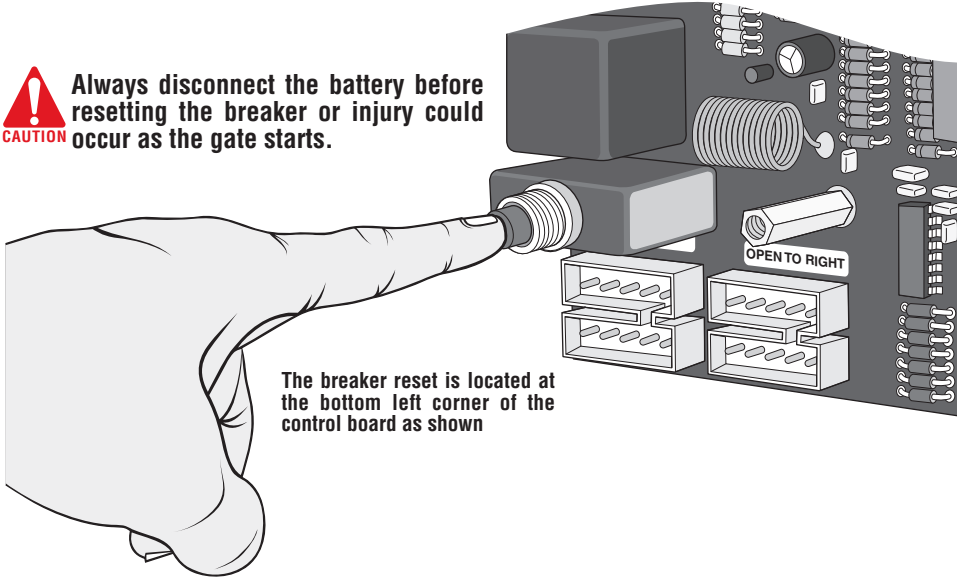

How to Check the Fuses

If the gate is not moving in any direction be sure to check all of the LED displays on the control board. If the board power or charging power LEDs are “ON”, change the corresponding fuse on the top left corner of the board.



Replace fuse with
1.5A - 250V fuse

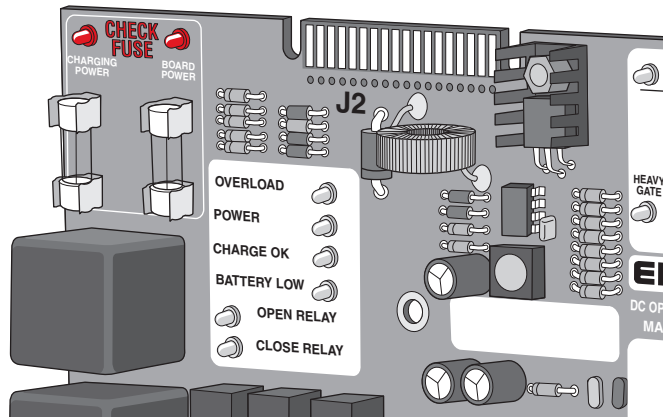
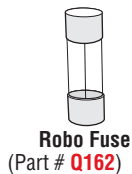

TROUBLESHOOTING

The Gate Will Not Close!

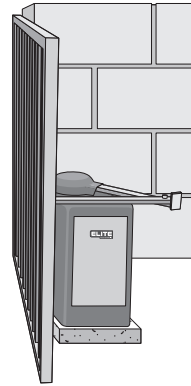
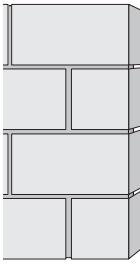

Symptom: The radio receiver LED on the control board remains “ON” when using the remote control.

Possible Solutions: Stuck remote control button. The radio receiver has malfunctioned in the “ON” position.

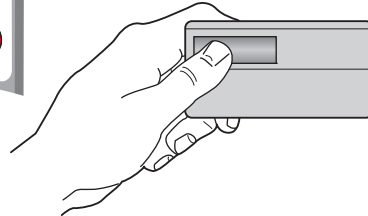
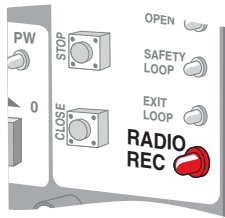

The Gate Will Not Open!

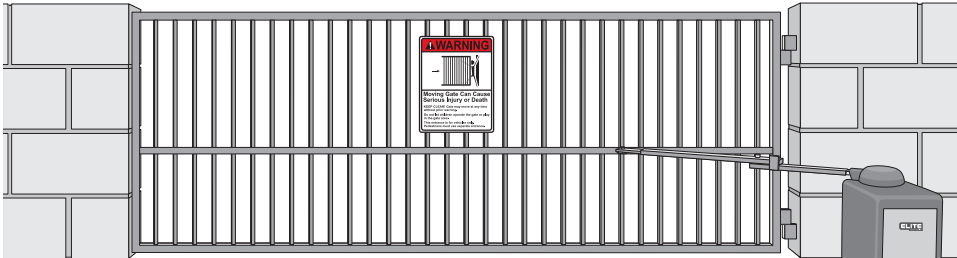

Symptom: The radio receiver LED on the control board remains “OFF” when using the remote control.

Possible Solutions: Dead battery in the remote control. Remote control code switches are different from radio receiver code switches. The radio receiver has malfunctioned in the “OFF” position.

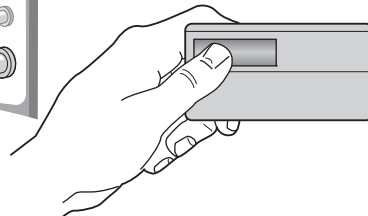
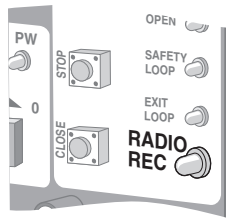

For further information, contact your local dealer.

A U D I O A L A R M

If you hear a  “BEEP” sound.....



The gate is TOO heavy



The operator arm or gate is incorrectly installed.

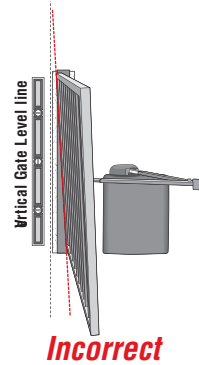
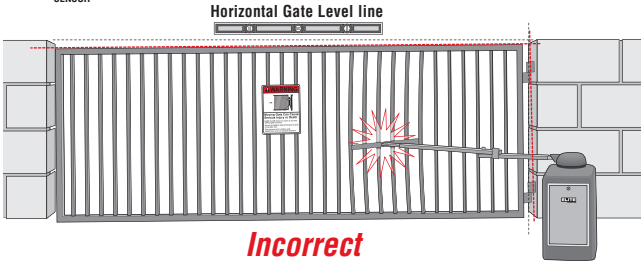

A foreign object is on the gate frame while the gate is moving.



The gate is moving and a car pushes the gate.

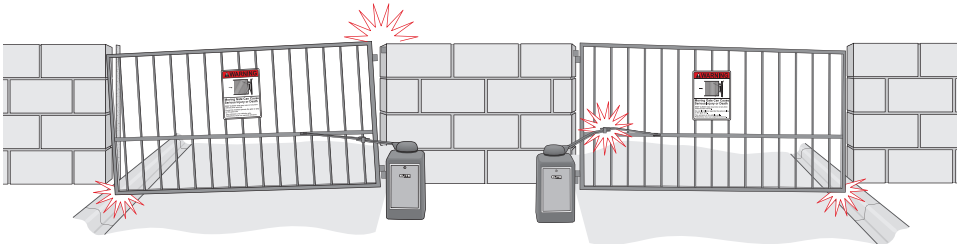

Gate hinges are too tight or broken and the gate is not moving freely



The gate hits the driveway, curb or other, and gets stuck or bent in an awkward position.

ROBO SWING PARTS

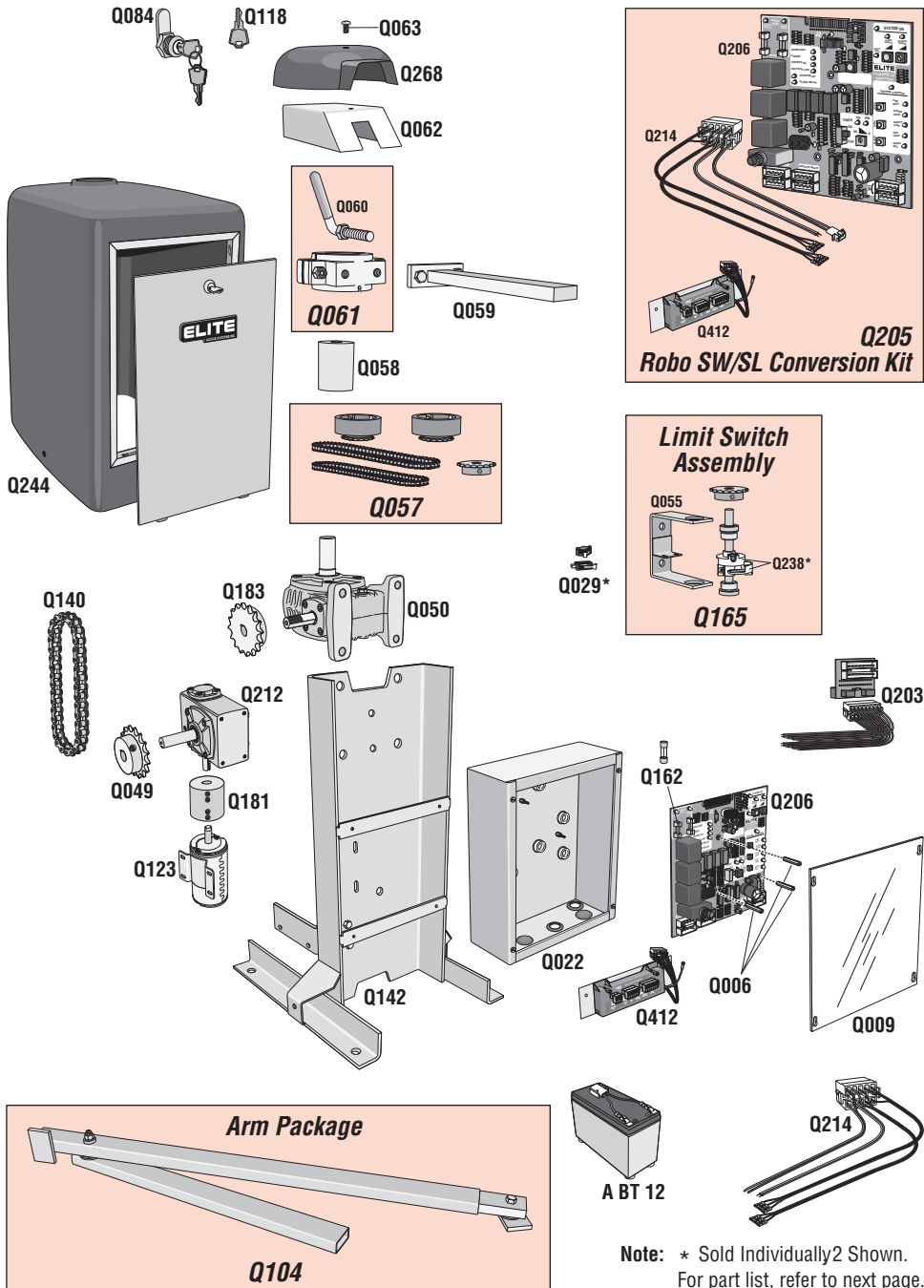

PARTS LIST

Robo SW / SL Conversion Kit

- Q205** { Q206 - Control Board
Q214 - Limit/Motor Harness
Q412 - Surge Suppressor Terminal

Limit Switch Assembly

- Q165** { Q238 - Gate Adjustment (Plastic Part)
Q055 - Limit Switch Bracket

Arm Package Q104

Cludge Assembly

- Q061** { Q060 - Arm Release Handle
Q061 - Output Shaft Cludge (T)

Sprocket and Chain Kit

- Q057** { 1 1/8" dia. sprocket fits size 70 gear box
1" dia. sprocket fits size 60 gear box
Sprocket #35
Chain #35-72 links
Chain #35-68 links

- A BT 12 - 12 VDC, 7 amp. Battery
Q006 - PC Board Nuts (1 Set)
Q009 - Electronic Access Panel
Q022 - Electronic Box
Q029 - Limit Switch
Q049 - Sprocket (B50-16)
Q050 - Gear Reducer (Size 60)
Q058 - Output Shaft 2 1/2"
Q059 - Output Arm (Solid)
Q062 - Stainless Steel Cludge Cover
Q063 - Security Bolt
Q084 - Emergency Key Release
Q118 - Key for Access Door
Q123 - Motor - DC - 12V
Q140 - Chain #50 (Robo Swing)
Q142 - Chassis - Robo Swing
Q162 - Fuse - Robo
Q181 - Coupling 2 1/2"
Q183 - Sprocket 50B16 5/8" Bore
Q203 - Option Board with Harness
Q206 - Electronic Control Board
Q212 - Gear Reducer 40 - 30:1
Q214 - Limit/Motor Harness
Q244 - Cover, Polyethylene Robo Swing
Q268 - Plastic Cludge Cover
Q412 - Surge Suppressor Terminal

Note:

Multiple Parts "Q" Number

MAINTENANCE

1. The gate area should be kept clean to insure proper operation.
2. Make sure the hinges are working smoothly and lubricated properly.
3. Make sure gate arm is greased properly.
4. Keep the cover clean.
5. Check gate reversing sensor.
6. Check for proper synthetic oil level in the upper gear box. (Mobil 10W-30 weight synthetic oil)
7. For parts, refer to Robo Swing parts page and this page.

HOW TO ORDER REPAIR PARTS

OUR LARGE SERVICE ORGANIZATION SPANS AMERICA

Installation and service information are available.

Call our TOLL FREE number:

1-800-528-2806

www.liftmaster.com

If you need further assistance, please call your local service company.

ELITE ROBO SWING ACCESSORIES

12 Vdc Radio Receiver

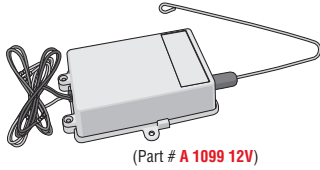

(Part # **A 1099 12V**)

Transmitter



(Part # **A 3089**)

12 Vdc Photo Beam

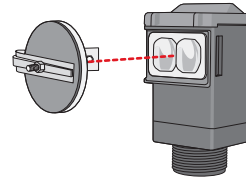

(Part # **A OMRON 12V**)

25 Vdc Plug-in Transformer



(Part # **A POW 1**)

Solar Panel

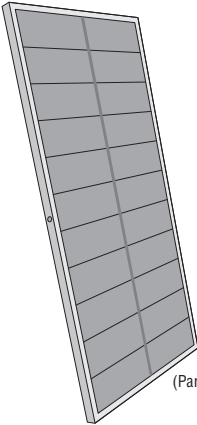

(Part # **SOLAR 3**)

12 Vdc 30 AHr Battery

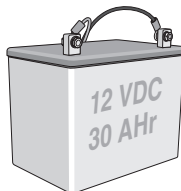

(Part # **A 12330**)



Magnetic Locks (Outdoor)

(Part # **A MG 1300**)

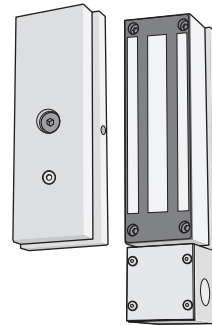

12 Vdc External Loop Detectors

(Part # **A 23**)

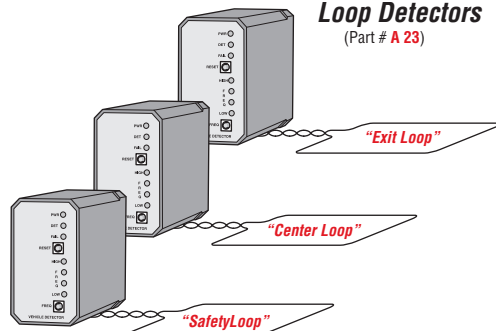

OWNERS CHECKLIST OF INSTALLATION

1. Owner and Installer must read all warnings and safety precautions and be aware of their roles and responsibilities. (Pages 2-8)
2. Make sure concrete mounting pad is big enough and deep enough for operator. (Page 9)
3. Operator must be **securely** fastened to concrete pad. (Page 9)
4. Operator arm must be **level** and welded properly to gate. (Page 12)
5. Rectangular tubes on operator arm must be **completely** welded around. (Page 12)
6. When gate is pulled, **No** slippage of operator arm should occur. (Page 14)
7. Gate operator must be grounded to an earth ground rod within 3 feet. (Page 15)
8. Verify that both the battery and plug-in transformer are connected properly. (Page 16)
9. Verify that the gate opens and closes as needed. (Page 19)
10. When gate hits object during operation, it **must** stop or reverse. (Page 20)
11. **Know how to operate the emergency release.** (Page 21)
12. Make sure that any pinch point or potential entrapment are guarded by means of safety devices or like. (Page 22)
13. Warning placards need to be permanently mounted on **both** sides of gate. (Page 20)
14. Test all additional equipment connected to operator.
15. Make sure **all** wire connections are **securely** fastened.
16. Review typical maintenance on operator. (Page 41)
17. Schedule periodic maintenance on operator by qualified service technician.
18. Inquire about Manufacturers "*operator warranty*". (Warranty Card Included with operator)
19. Inquire about **separate** "*installation warranty*" with installer.

FEATURES AND SPECIFICATIONS

We suggest the following items manufactured by Chamberlain Professional Products for better and safer operations.

POWER HINGES

Heavy duty industrial swing gate hinges for high traffic use.

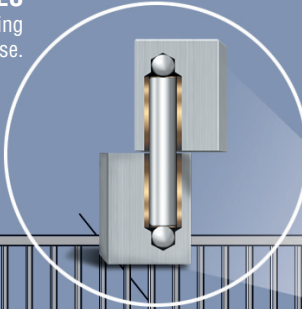

MG-1300 MAGNETIC LOCKS

Offering up to 1300 pounds of holding force and an attached junction box.



WARNING SIGNS

Use a warning sign on gate to prevent injury to children.



To insure a strong gate installation, weld a horizontal bar across the entire gate. Then weld the arm attachment onto the bar.