

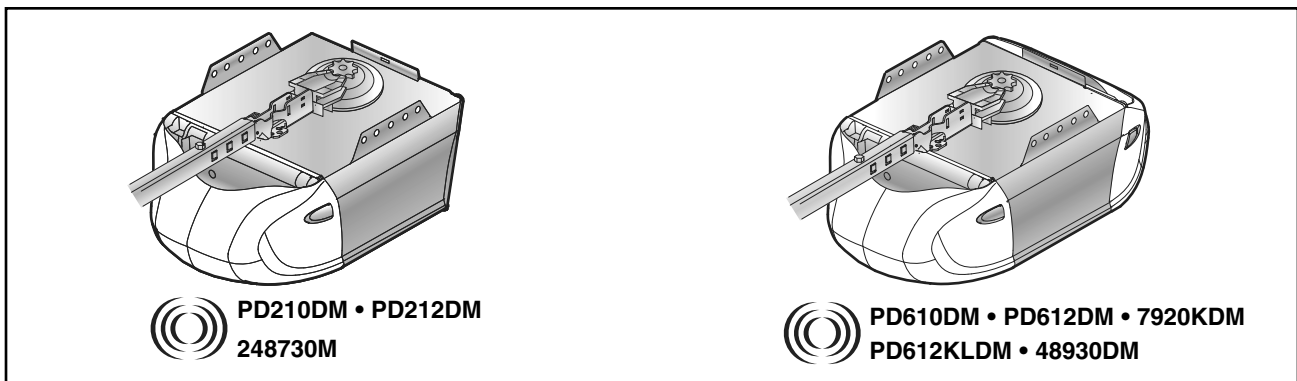

GARAGE DOOR OPENER ASSEMBLY/ INSTALLATION MANUAL

- Please read this manual and the enclosed safety materials carefully!
- Fasten the manual near the garage door after installation.
- The door **WILL NOT CLOSE** unless the Protector System® is connected and properly aligned.
- Periodic checks of the opener are required to ensure safe operation.
- The model number label is located under the light lens on the front panel of your opener.



There are two types of garage door openers pictured. Yours may appear slightly different.

IMPORTANT SAFETY NOTES

This garage door opener has been designed and tested to offer safe service provided it is installed, operated, maintained and tested in strict accordance with the instructions and warnings contained in this manual.

⚠ WARNING

Mechanical

⚡ WARNING

Electrical

CAUTION

When you see these Safety Symbols and Signal Words on the following pages, they will alert you to the possibility of **serious injury** or **death** if you do not comply with the warnings that accompany them. The hazard may come from something mechanical or from electric shock. Read the warnings carefully.

When you see this Signal Word on the following pages, it will alert you to the possibility of damage to your garage door and/or the garage door opener if you do not comply with the cautionary statements that accompany it. Read them carefully.

TABLE OF CONTENTS

<p>Preparing Your Garage Door 2</p> <p>Completed Installation 3</p> <p>Tools Needed 4</p> <p>Opener Contents 4</p> <p>Assembly Hardware 5</p> <p>Installation Hardware 5</p> <p>Assembly 6-8</p> <p>Installation</p> <p>Installation safety instructions 9</p> <p>Install the header bracket 10</p> <p>Mount the header bracket 11</p> <p>Position and hang motor unit 12</p> <p>Fasten the door bracket 13</p> <p>Attach door to trolley 14</p> <p>Installing the door control 15</p> <p>Installing the light bulb(s) 16</p> <p>Electrical requirements 16</p> <p>Install the Protector System® 17-18</p> <p>Wire safety sensor 19</p> <p>Adjustment</p> <p>Adjust the UP and DOWN travel limits 20</p> <p>Adjust the forces 21</p> <p>Test the safety reversal system 22</p> <p>Test the Protector System® 22</p>	<p>Operation</p> <p>Important Safety Information 23</p> <p>Using your garage door opener 23</p> <p>Using the wall-mounted door control 24</p> <p>Care of your opener 24</p> <p>To open the door manually 24</p> <p>Having a Problem? 25</p> <p>Diagnostic Chart 26</p> <p>Programming</p> <p>To add or reprogram an additional hand-held remote control 27</p> <p>To control the opener lights 27</p> <p>Multi-function remotes 27</p> <p>To add, reprogram or change a keyless entry PIN 28</p> <p>To change an existing, known PIN 28</p> <p>To set a temporary PIN 29</p> <p>To erase all codes from motor unit memory 29</p> <p>The remote control battery 29</p> <p>Repair Parts</p> <p>Rail assembly parts 30</p> <p>Installation parts 30</p> <p>Motor unit assembly parts 31</p> <p>Accessories 32</p> <p>Notes 33-34</p> <p>Warranties 35</p> <p>Repair Parts and Service 36</p>
--	--

PREPARING YOUR GARAGE DOOR

Before you begin:

- Disable locks (contact your door manufacturer for information on disabling your door locks.)
- Remove any ropes connected to garage door.
- **Complete the following test** to make sure your garage door is balanced and is not sticking or binding:
 1. Lift the door about halfway as shown. Release the door. If balanced, it should stay in place, supported entirely by its springs.
 2. Raise and lower the door to see if there is any binding or sticking.

If your door binds, sticks, or is out of balance, call a trained door systems technician.

If you have a one-piece door, the installation of your garage door opener will be different. Follow the assembly instructions included in this manual then proceed to the *Installation Instructions For One-Piece Doors* included with the garage door opener.

⚠ WARNING

To prevent possible **SERIOUS INJURY** or **DEATH**:

- **ALWAYS** call a trained door systems technician if garage door binds, sticks, or is out of balance. An unbalanced garage door may not reverse when required.
- **NEVER** try to loosen, move or adjust garage door, door springs, cables, pulleys, brackets or their hardware, **ALL** of which are under **EXTREME** tension.
- Disable **ALL** locks and remove **ALL** ropes connected to garage door **BEFORE** installing and operating garage door opener to avoid entanglement.

CAUTION

To prevent damage to garage door and opener:

- **ALWAYS** disable locks **BEFORE** installing and operating the opener.
- **ONLY** operate garage door opener at 120V, 60 Hz to avoid malfunction and damage.

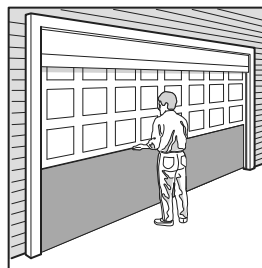

Sectional Door

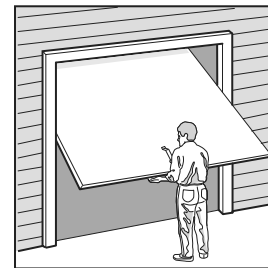

One-Piece Door
See addendum

PLANNING

Identify the type and height of your garage door. If you have a one-piece door, follow the assembly instructions contained in this manual and refer to the Installation Instructions One-Piece Door for installation procedures. Survey your garage area to see if any of the conditions below apply to your installation. Additional materials may be required. You may find it helpful to refer back to this page and the accompanying illustrations as you proceed with the installation of your opener.

Depending on your requirements, there are several installation steps which may call for materials or hardware not included in the carton.

- *Installation Page 10* – Look at the wall or ceiling above the garage door. The header bracket must be securely fastened to structural supports.
- *Installation Page 12* – Do you have a finished ceiling in your garage? If so, a support bracket and additional fastening hardware may be required.
- *Installation Page 13* – Do you have a steel, aluminum, fiberglass or glass panel door? If so, horizontal and vertical reinforcement is required.
- *Installation Page 18* – Depending upon garage construction, extension brackets or wood blocks may be needed to install sensors.
- *Installation Page 18* – Alternate floor mounting of the safety reversing sensor will require hardware not provided.

WARNING

Without a properly working safety reversal system, persons (particularly small children) could be SERIOUSLY INJURED or KILLED by a closing garage door.

- The gap between the bottom of the garage door and the floor **MUST NOT** exceed 1/4" (6 mm). Otherwise, the safety reversal system may not work properly.
- The floor or the garage door **MUST** be repaired to eliminate the gap.
- Do you have an access door in addition to the garage door? If not, Model 7702CB Outside Quick Release is required. See Accessories page.
- Look at the garage door where it meets the floor. Any gap between the floor and the bottom of the door must not exceed 1/4" (6 mm). Otherwise, the safety reversal system may not work properly. See Adjustment Step 3. Floor or door should be repaired.
- The opener should be installed above the center of the door. If there is a torsion spring or center bearing plate in the way of the header bracket, it may be installed within 4 feet (1.22 m) to the left or right of the door center.
- If your door is more than 7 feet (2.13 m) high, see rail extension kits listed on Accessories page 32.

COMPLETED INSTALLATION

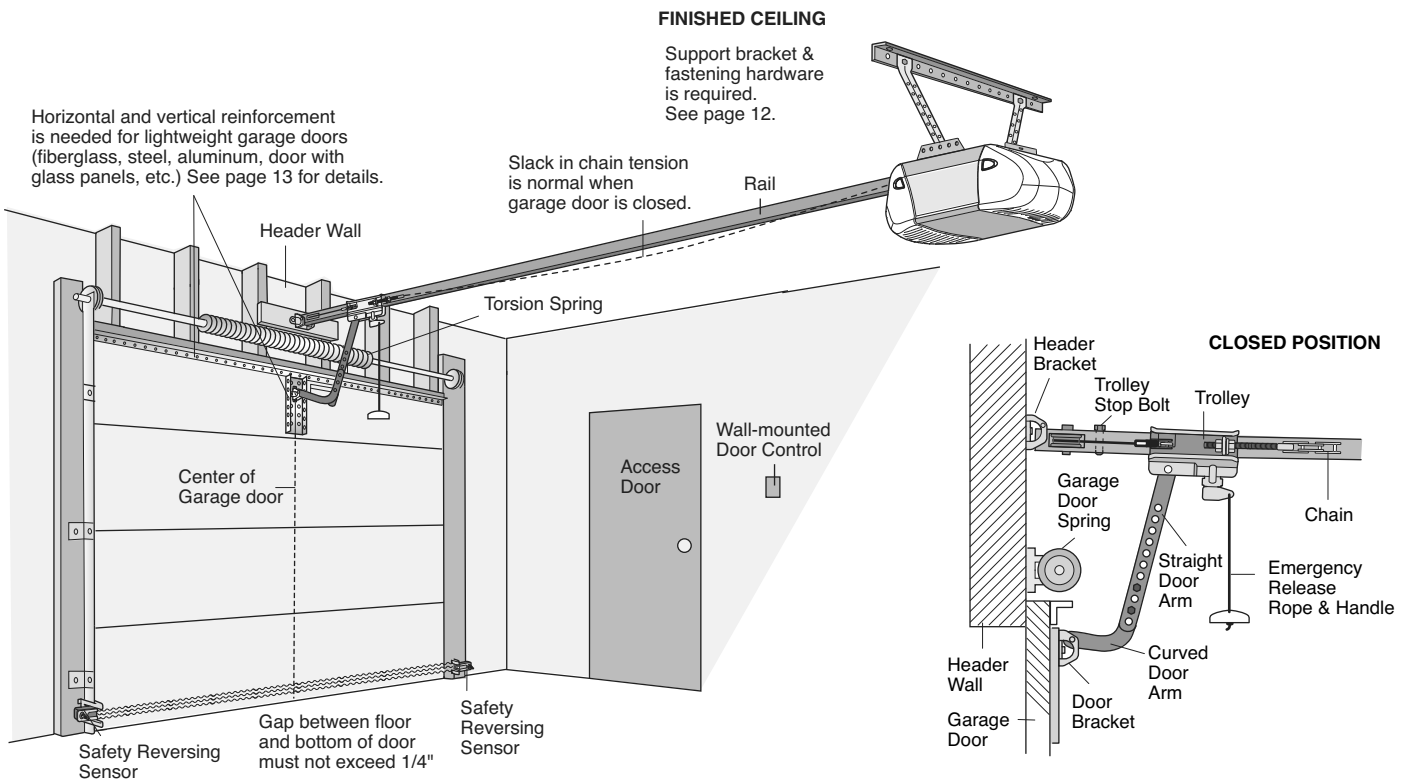

TOOLS NEEDED

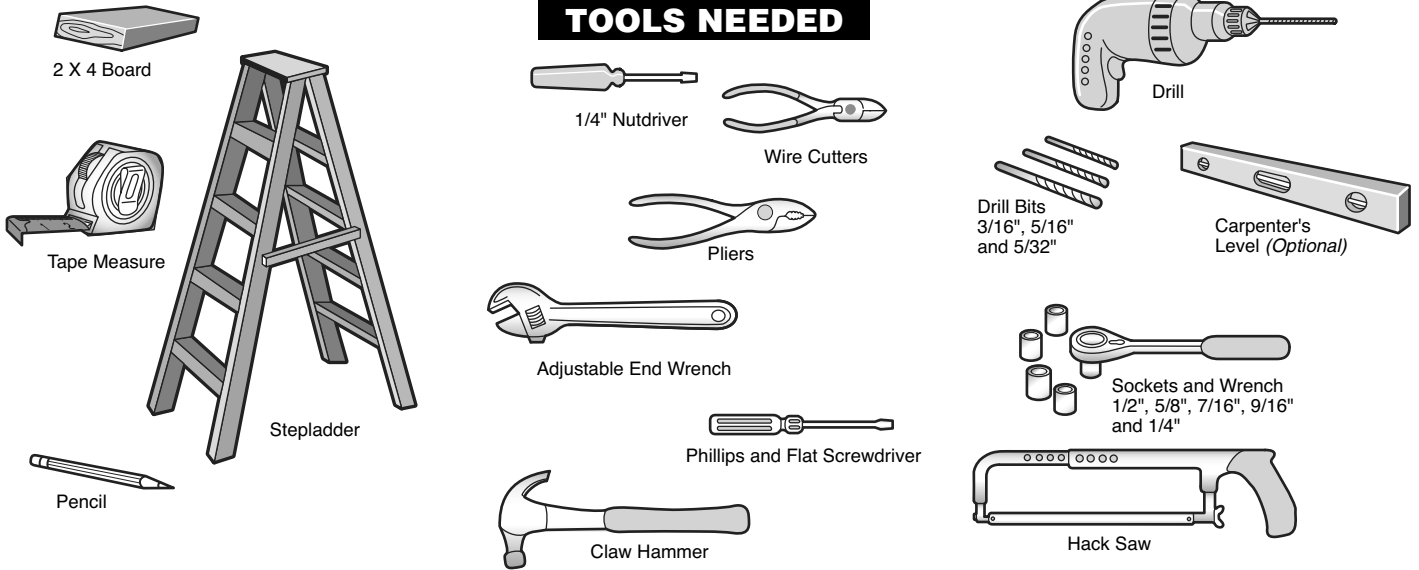

Your garage door opener is packaged in one carton which contains the motor unit and the parts illustrated below. Note that accessories will depend on the model purchased. If anything is missing, carefully check the packing material. Parts may be stuck in the foam. Hardware for assembly and installation is shown on the next page. Save the carton and packing material until installation and adjustment is complete.

OPENER CONTENTS

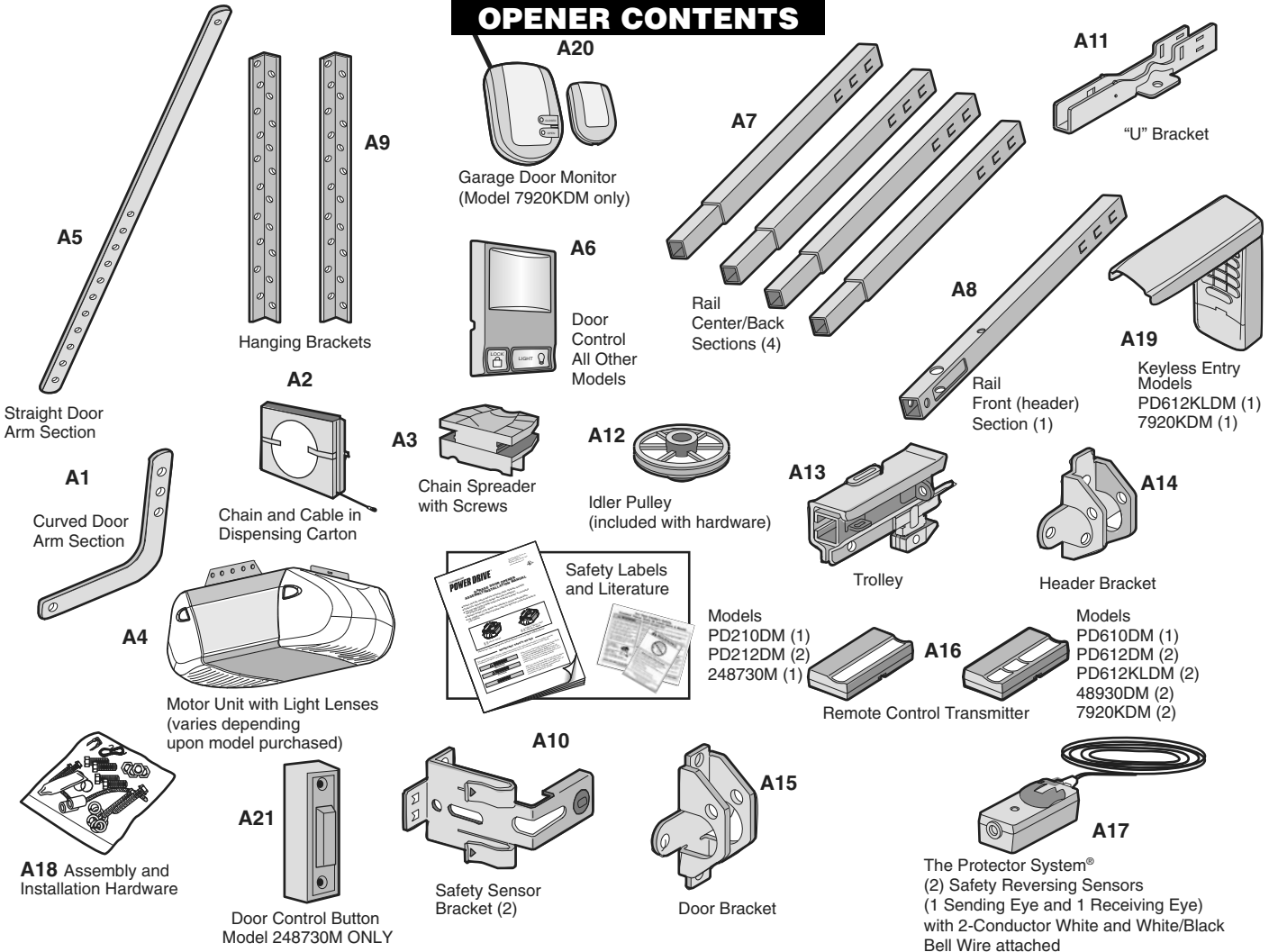

ASSEMBLY HARDWARE

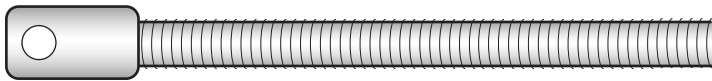

B1 Threaded
Trolley Shaft (1)

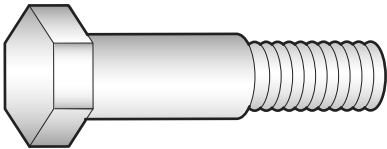

B5 Idler Bolt (1)



B6 Bolt 1/4" - 20 x 1-3/4" (2)



B7 Nut 3/8" (1)

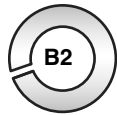

B2
Lock Washer
3/8" (1)

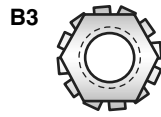

B3
Lock Nut
1/2" - 20 (2)

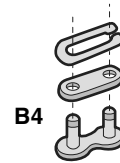

B4
Master Link (2)

INSTALLATION HARDWARE

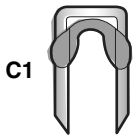

C1
Insulated
Staples (30)



C2
Spacer (2)

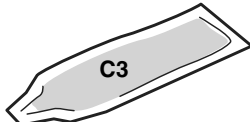

C3
Rail Grease



C4
Nut 5/16" - 18 (4)

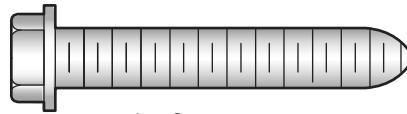

C8 Lag Screw
5/16"-18 x 1-7/8" (2)

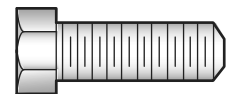

C9 Hex Bolt
5/16"- 18 x 7/8" (4)

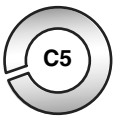

C5
Lock Washer
5/16" (7)



C6
Ring
Fastener (3)



C7
Clevis Pin
5/16" x 1-1/4" (1)

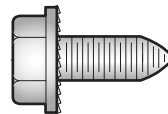

C10 Self-Threading Screw
1/4"-14 x 5/8" (2)



C11
Clevis Pin
5/16" x 1-1/2" (1)



C12 Screw
6AB x 1-1/4" (2)

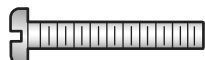

C13 Screw 6-32 x 1" (2)

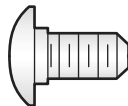

C14 Carriage Bolts
1/4"-20 x 1/2" (2)

C19



Rope

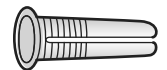

C15 Drywall
Anchors (2)

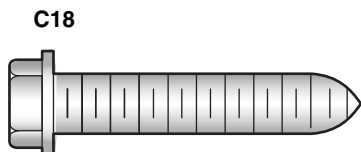

C18
Lag Screw
5/16"- 9 x 1-5/8" (2)

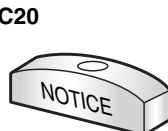

C20
Handle (not shown
actual size)

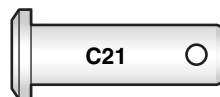

C21
Clevis Pin
5/16" x 1" (1)

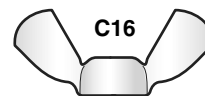

C16
Wing Nut
1/4 x 20 (2)



C17
2-Conductor Bell Wire
White & White/Red

ASSEMBLY

CAUTION

To prevent INJURY from pinching, keep hands and fingers away from the joints while assembling the rail.

1 Assemble the Rail

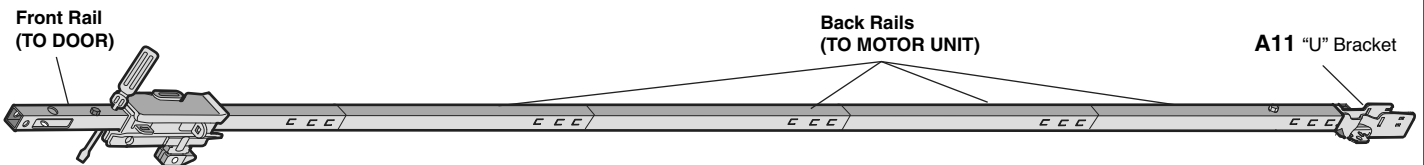
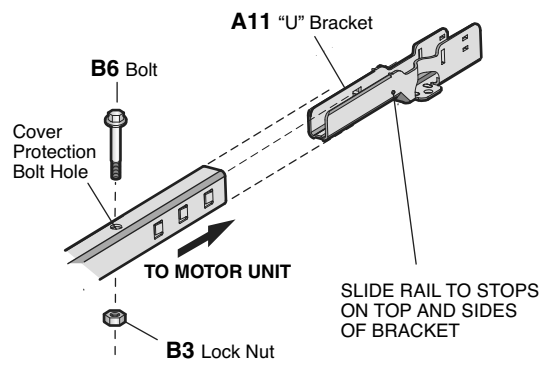
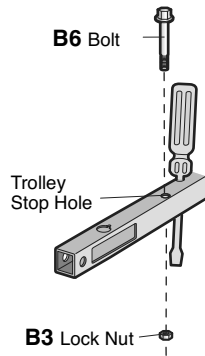
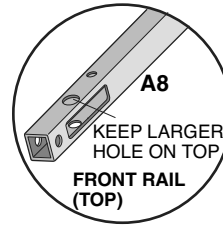
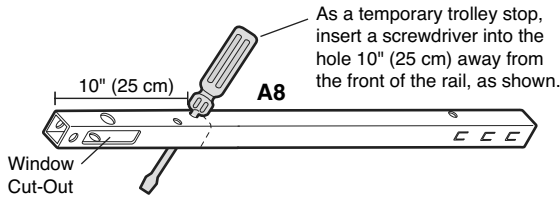
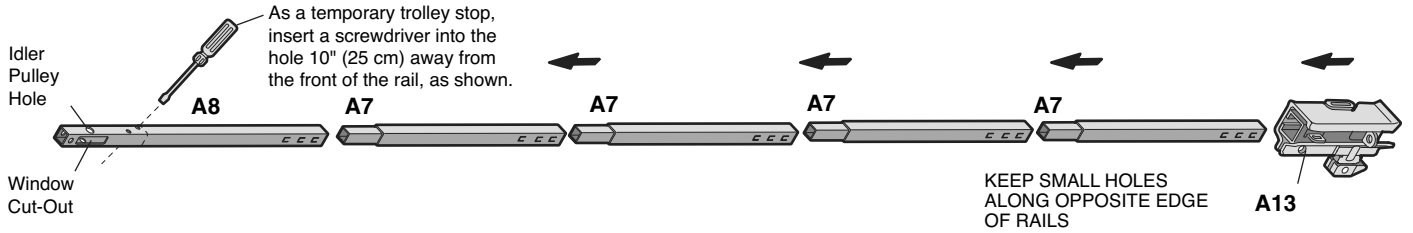

ALL HARDWARE SHOWN ACTUAL SIZE



B6 Bolt

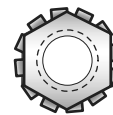

B3 Lock Nut

CAUTION

To avoid serious damage to opener, **ONLY** use bolts/fasteners mounted in top of motor unit.

2 Remove Fasteners from Top of Motor Unit

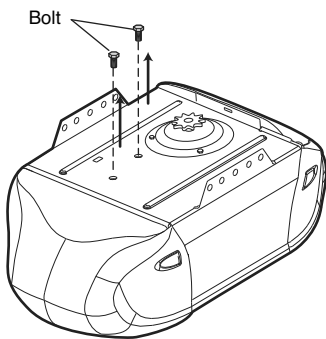

3 Attach Rail to Motor Unit

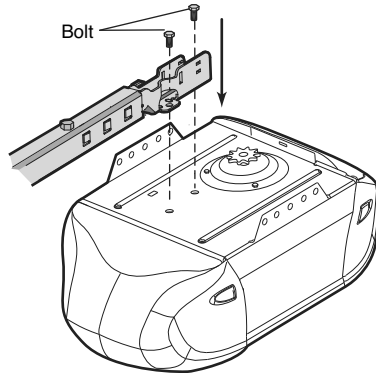

4 Attach Chain Spreader

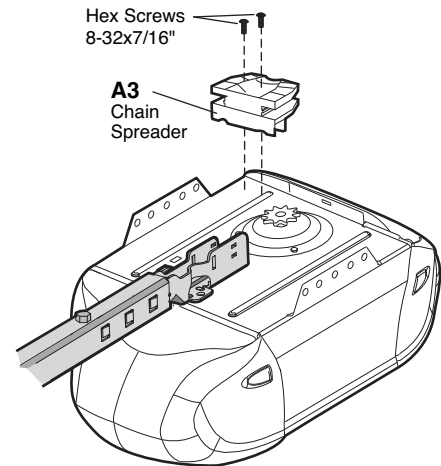

5 Run Cable Through Cut-Out Window

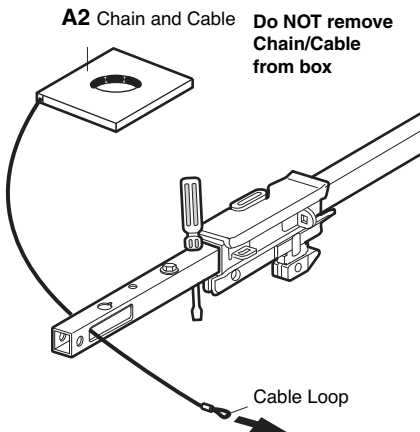

6 Install Idler Pulley

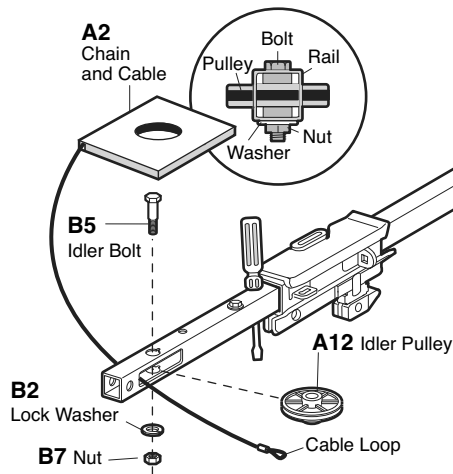

7 Attach Cable to Front of Trolley

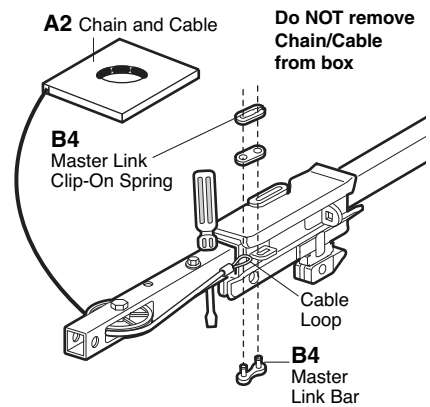

ALL HARDWARE SHOWN ACTUAL SIZE

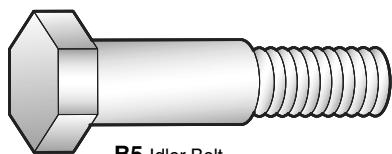

B5 Idler Bolt



B3 Lock Nut



B7 Nut



B2 Lock Washer

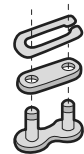

B4 Master Link

CAUTION

To avoid possible **SERIOUS INJURY** to fingers:

- Securely attach chain spreader.
- **NEVER** connect garage door opener to power source until instructed to do so.

8 Route Chain/Cable Around Rail Assembly and Motor Unit Sprocket

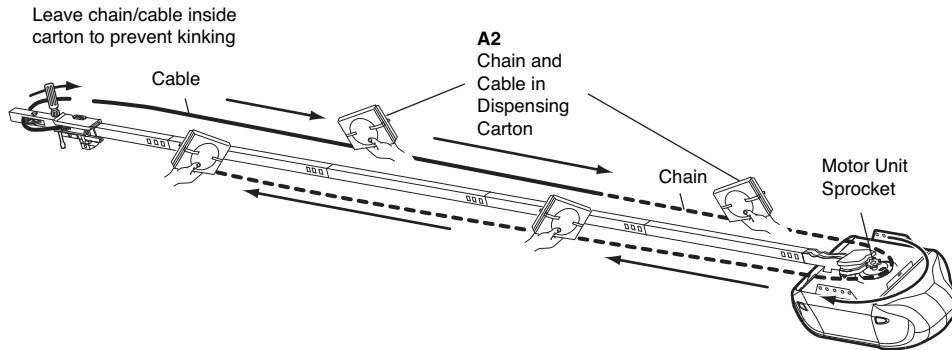

9 Attach Chain To Trolley Threaded Shaft

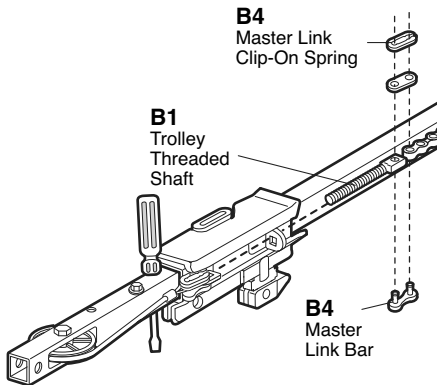

10 Attach Nut and Lock Washer to Trolley Threaded Shaft

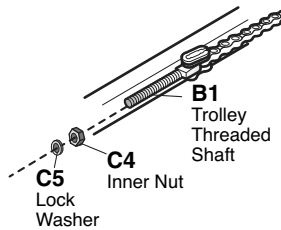

11 Insert Trolley Threaded Shaft into Round Hole in Trolley

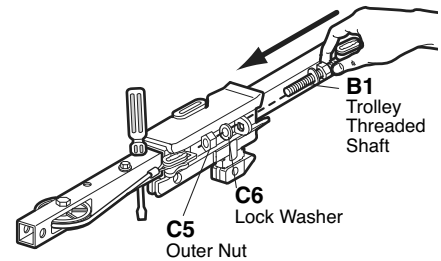

12 Tighten the Chain

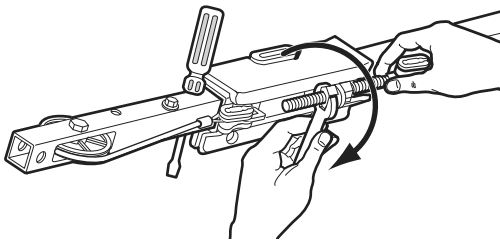

Desired Chain Tension

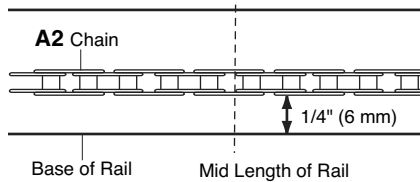

Assembly of your opener is now complete.

ALL HARDWARE SHOWN ACTUAL SIZE

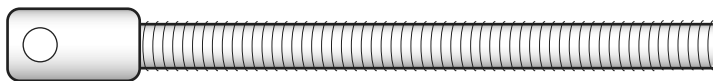

B1 Threaded Trolley Shaft

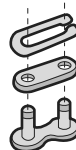

B4 Master Link



C4 Nut



C5 Lock Washer

INSTALLATION

IMPORTANT INSTALLATION INSTRUCTIONS



To reduce the risk of SEVERE INJURY or DEATH:

1. READ AND FOLLOW ALL INSTALLATION WARNINGS AND INSTRUCTIONS.
2. Install garage door opener ONLY on properly balanced and lubricated garage door. An improperly balanced door may not reverse when required and could result in SEVERE INJURY or DEATH.
3. ALL repairs to cables, spring assemblies and other hardware MUST be made by a trained door systems technician BEFORE installing opener.
4. Disable ALL locks and remove ALL ropes connected to garage door BEFORE installing opener to avoid entanglement.
5. Install garage door opener 7 feet (2.13 m) or more above floor.
6. Mount emergency release handle 6 feet (1.83 m) above floor.
7. NEVER connect garage door opener to power source until instructed to do so.
8. NEVER wear watches, rings or loose clothing while installing or servicing opener. They could be caught in garage door or opener mechanisms.
9. Install wall-mounted garage door control:
 - within sight of the garage door
 - out of reach of children at minimum height of 5 feet (1.5 m)
 - away from ALL moving parts of the door.
10. Place entrapment warning label on wall next to garage door control.
11. Place manual release/safety reverse test label in plain view on inside of garage door.
12. Upon completion of installation, test safety reversal system. Door MUST reverse on contact with a 1-1/2" high (3.8 cm) object (or a 2 x 4 laid flat) on the floor.

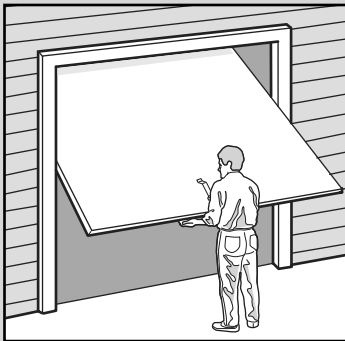

One-Piece Door

If you have a one-piece door, proceed to the One-Piece Door Installation Instructions included with your garage door opener.

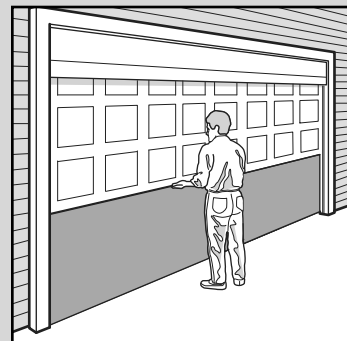
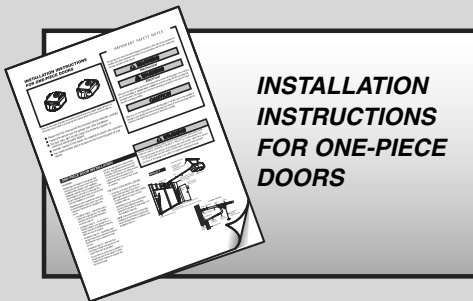

Sectional Door

If you have a sectional door, proceed to page 10 of this manual.

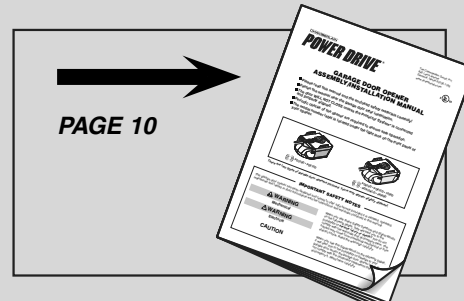

INSTALLATION

WARNING

To prevent possible **SERIOUS INJURY** or **DEATH**:

- Header bracket **MUST** be **RIGIDLY** fastened to structural support on header wall or ceiling, otherwise garage door might not reverse when required.
- **NEVER** try to loosen, move or adjust garage door, springs, cables, pulleys, brackets, or their hardware, **ALL** of which are under **EXTREME** tension.

INSTALL THE HEADER BRACKET

NOTE: You can fasten the header bracket within 4 feet (1.2 m) of the left or right of the door center only if a torsion spring or center bearing plate is in the way; or you can attach it to the ceiling when clearance is minimal.

Fasten header bracket securely to structural supports. It may be necessary to use a 2 x 4 as a structural support if installing on drywall or between two studs as shown in Step 3. Securely fasten 2 x 4 to structural supports using lag screws (not provided). Concrete anchors must be used if mounting header bracket or 2 x 4 into masonry.

1 Mark the Center of the Garage Door

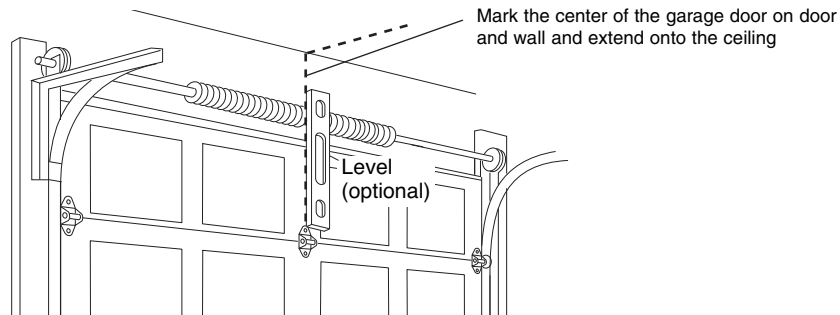

2 Determine the Highest Point of Travel, and Draw Horizontal Line for Header Bracket Placement

Mark a spot on the "center of the garage door" line, 2" (5 cm) above the highest point of travel of the garage door

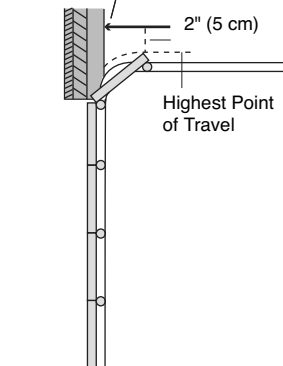

3 Add a 2 x 4 as a Structural Support (If Necessary)

-In some installations it may be necessary to install a 2x4 across two studs to create a location for header bracket or over drywall

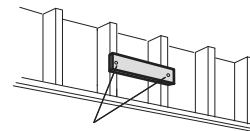

Use lag screws (not provided) to secure 2x4 (structural support) into wood. Use concrete anchors to secure 2x4 into masonry.

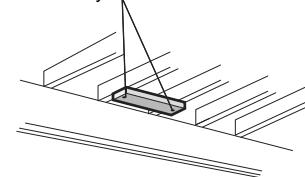

MOUNT THE HEADER BRACKET

4 Mark Bracket Holes

Center bracket on the "center of garage door" line and the horizontal line made in Step 2.

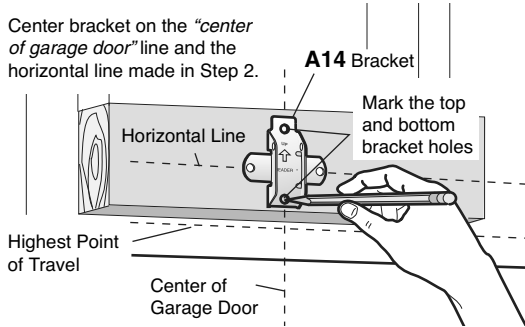

5 Drill Holes

Drill two 3/16" pilot holes

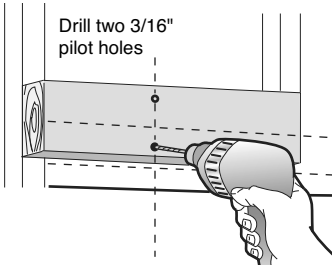

6 Attach Bracket

Secure bracket with lag screws

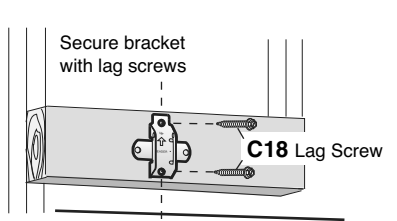

Ceiling Mount the Header Bracket (Optional)

NOTE: If your installation requires that the header bracket be mounted to the ceiling. The back edge of the bracket **MUST NOT** be further than 6" (15 cm) from the header wall and the arrow **MUST** point away from the header wall.

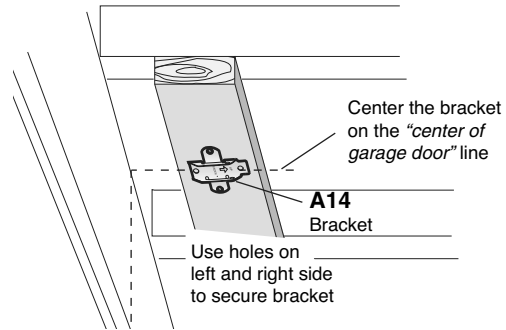

7 Attach Rail to the Header Bracket

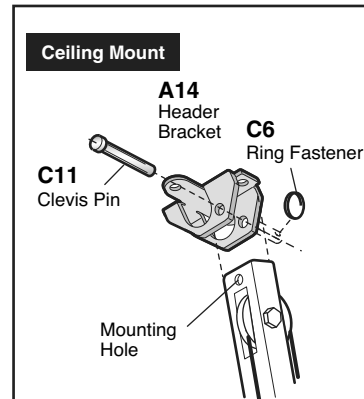
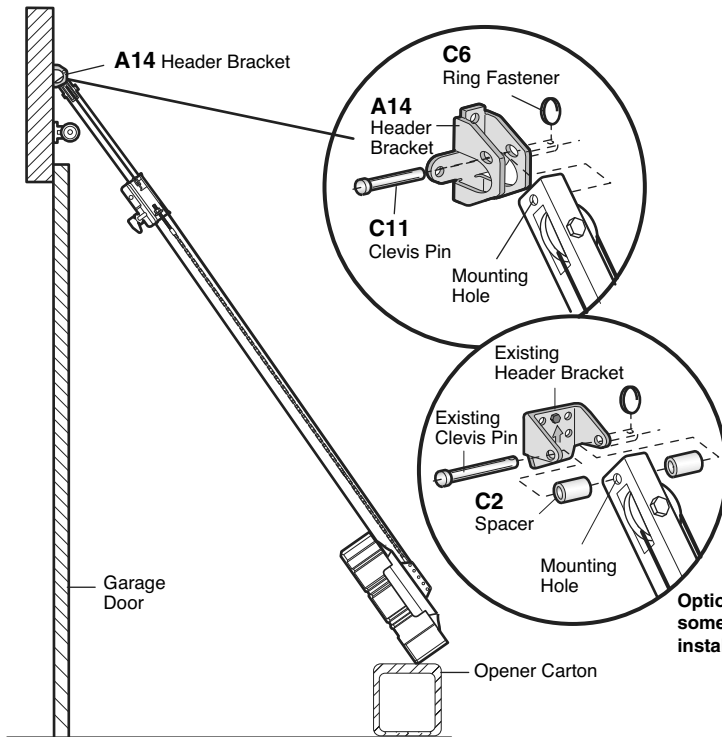

NOTE: If the door spring is in the way, you'll need help. Have someone hold the opener securely on a temporary support to allow the rail to clear the spring.

ALL HARDWARE SHOWN
ACTUAL SIZE

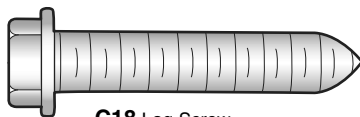

C18 Lag Screw



C11 Clevis Pin



C6 Ring Fastener

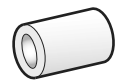

C2 Spacer

POSITION AND HANG MOTOR UNIT

- 1 Open Door to Full Open Position and Rest Rail on a 2x4 to Position Opener at the Proper Angle for Hanging from the Ceiling

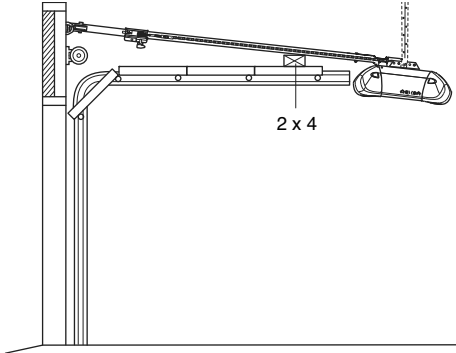

- 2 Attach Hanging Brackets to Ceiling and Fasten Motor Unit to Hanging Brackets

NOTE: Before the motor unit is secured to the ceiling, insure that the motor unit and rail are centered over the door. If you mounted the header bracket off center, hang the motor unit the same distance. Concrete anchors must be used if installing any brackets into masonry.

Option with finished or unfinished ceiling

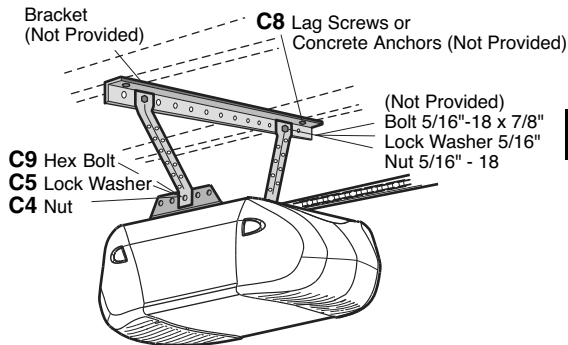

Option with unfinished ceiling

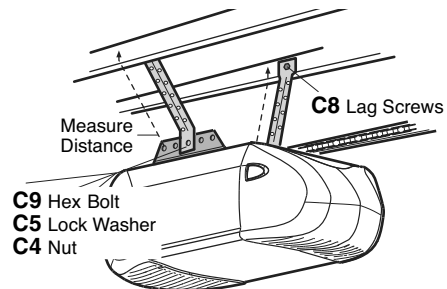

OR

- 3 Remove 2x4 and Close Door

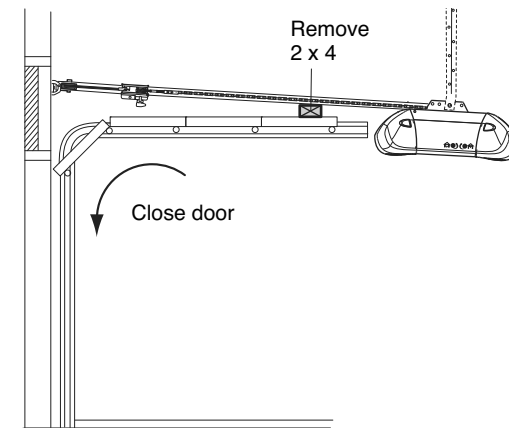

⚠ WARNING

To avoid possible **SERIOUS INJURY** from a falling garage door opener, fasten it securely to structural supports of the garage.

CAUTION

To prevent damage to garage door, rest garage door opener rail on 2 x 4 placed on top section of door.

If the top section or panel hits the trolley when you raise the door, pull down on the trolley release arm to disconnect inner and outer sections. Slide the outer trolley toward the motor unit. The trolley can remain disconnected until installation is completed.

NOTE: The garage door opener motor head will typically sit lower than the header bracket, therefore, the rail will be at an angle.

ALL HARDWARE SHOWN ACTUAL SIZE

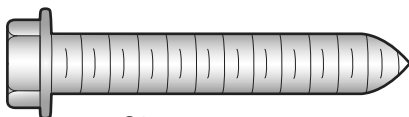

C8 Lag Screw

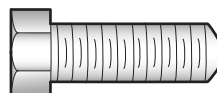

C9 Hex Bolt



C4 Nut



C5 Lock Washer

CAUTION

To prevent damage to garage door, reinforce inside of door with angle iron both vertically and horizontally.

HORIZONTAL AND VERTICAL REINFORCEMENT

Horizontal and vertical reinforcement (not provided) is needed for light weight garage doors (fiberglass, aluminum, steel, doors with glass panel, etc.).

A horizontal reinforcement brace should be long enough to be secured to two or three vertical supports. A vertical reinforcement brace should cover the height of the top panel. Contact your door manufacturer for more information regarding reinforcement of your door.

Many door reinforcement kits provide for direct attachment of the clevis pin and door arm. In this case, you will not need the door bracket; proceed to Connect Door Arm to Trolley section.

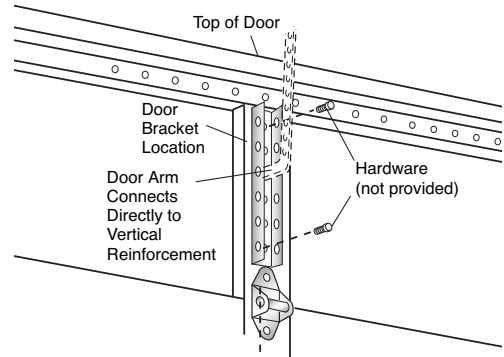

FASTEN THE DOOR BRACKET

1 Position Door Bracket

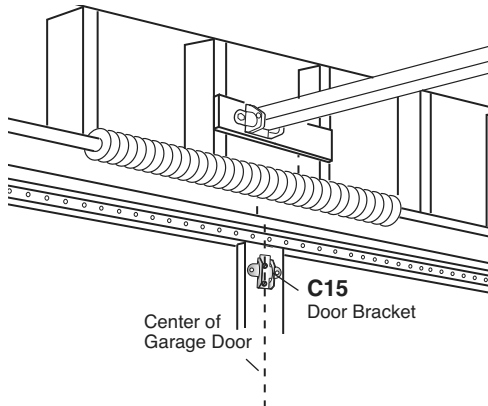

Position the door bracket on the face of the door within the following limits:

1. The top edge of the bracket 2"-4" (5-10 cm) below the top edge of the door.
2. The top edge of the bracket directly below any structural support across the top of the door.

2 Mark and Drill 3/16" Holes

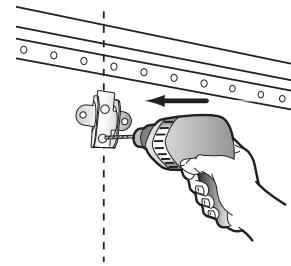

3 Fasten Door Bracket

Metal, insulated or lightweight factory reinforced doors

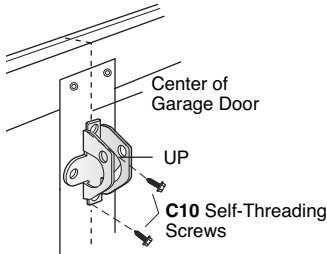

OR

Wood doors
Bolt
5/16" x 2"
(Not Provided)

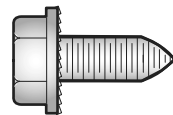
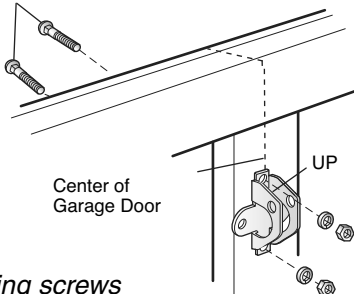

C10 Self-Threading Screw

**ALL
HARDWARE
SHOWN
ACTUAL SIZE**

NOTE: The 1/4"-14 x 5/8" self-threading screws are not intended for use on wood doors.

ATTACH DOOR TO TROLLEY

1 Attach Emergency Release Rope and Handle

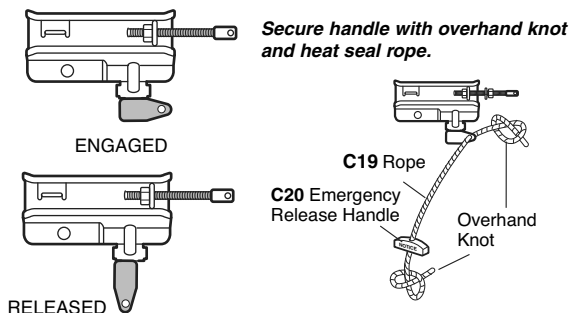

CONNECT DOOR ARM TO TROLLEY

2 Pull Emergency Release Rope to Disengage the Trolley

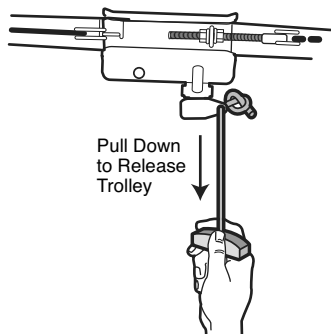

3 Slide Trolley Back 2" (5 cm) and Connect Straight Door Arm to the Trolley

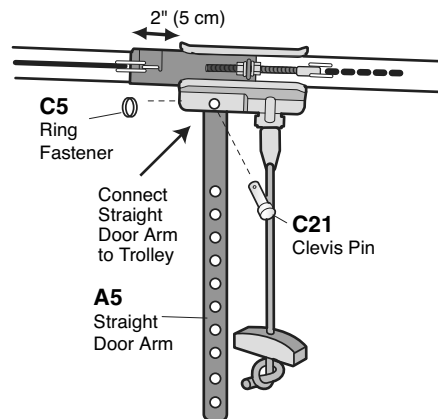

4 Connect Curved Door Arm to the Door Bracket

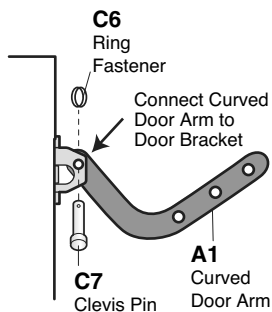

5 Ensure Door is Fully Closed and Connect Door Arms

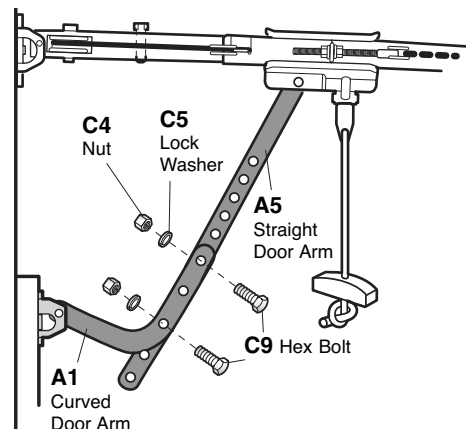

! WARNING

To prevent possible **SERIOUS INJURY** or **DEATH** from a falling garage door:

- If possible, use emergency release handle to disengage trolley **ONLY** when garage door is **CLOSED**. Weak or broken springs or unbalanced door could result in an open door falling rapidly and/or unexpectedly.
- **NEVER** use emergency release handle unless garage doorway is clear of persons and obstructions.
- **NEVER** use handle to pull door open or closed. If rope knot becomes untied, you could fall.

NOTE: Handle should hang 6 feet (1.5 m) above floor. Ensure that the rope and handle clear the tops of all vehicles to avoid entanglement.

ALL HARDWARE SHOWN ACTUAL SIZE



C7 Clevis Pin



C21 Clevis Pin



C6 Ring Fastener



C5 Lock Washer



C4 Nut

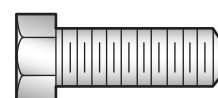

C9 Hex Bolt

⚠️ WARNING

To prevent possible **SERIOUS INJURY** or **DEATH** from electrocution:

- Be sure power is not connected **BEFORE** installing Door Control.
- Connect **ONLY** to 24 VOLT low voltage circuit.

To prevent possible **SERIOUS INJURY** or **DEATH** from a closing garage door:

- Install Door Control within sight of garage door, out of reach of children at a minimum height of 5 feet (1.5 m), and away from all moving parts of door.
- **NEVER** permit children to operate or play with door control push buttons or remote control transmitters.
- Activate door **ONLY** when it can be seen clearly, is properly adjusted, and there are no obstructions to door travel.
- **ALWAYS** keep garage door in sight until completely closed. **NEVER** permit anyone to cross path of closing garage door.

INSTALLING THE DOOR CONTROL

1 Strip Door Control Wire

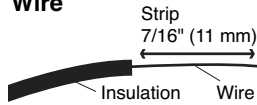

A21
Door Control Button

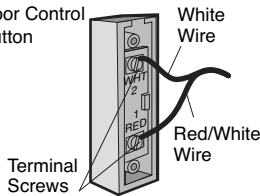

2 Connect Wire to Door Control

A6

Door Control: Multi-Function

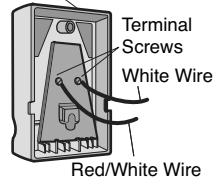

3 Position Door Control, Route Door Control Wire to Motor Unit and Secure with Insulated Staples. Permanently Mount 2 Safety Labels Using Adhesive Backing, Tacks or Staples, If Necessary.

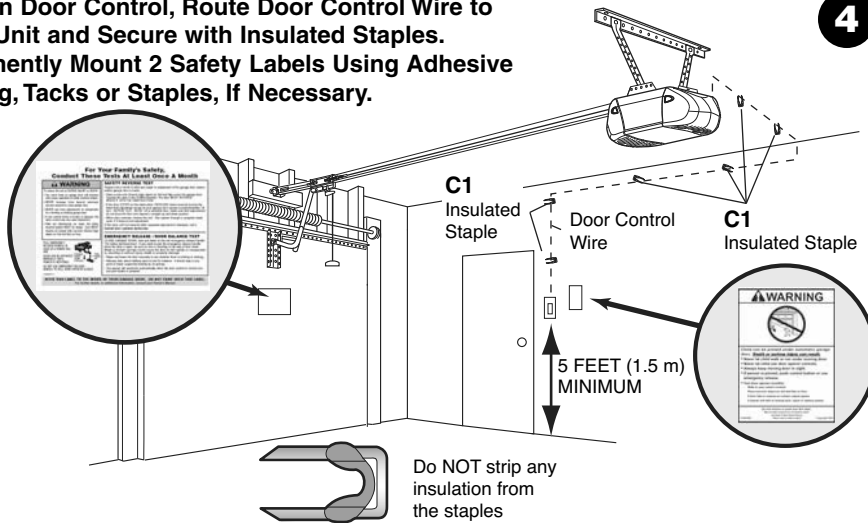

4 Carefully Remove Cover Multi-Function Door Controls ONLY

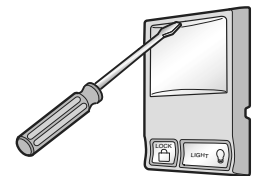

5 Attach Door Control to Wall and Replace Cover

Door Control Button

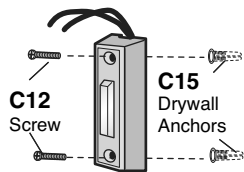

Multi-Function Door Control

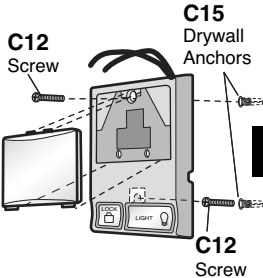

Multi-Function Door Control: If, No Gang Box is Present

OR

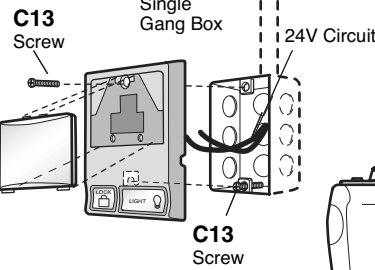

Multi-Function Door Control: Gang Box Installation

6 Connect Door Control Wires to Motor Unit

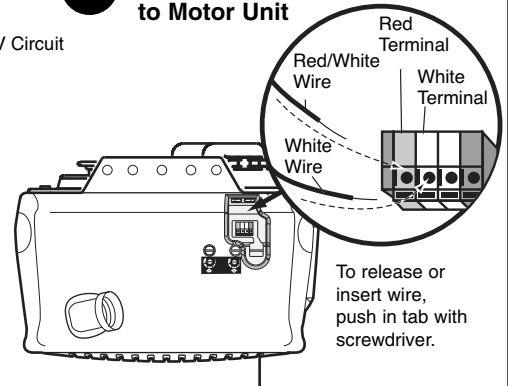

ALL HARDWARE SHOWN ACTUAL SIZE



C12 Screw



C15 Drywall Anchors



C13 Screw

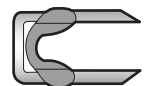

C1 Staples

INSTALLING THE LIGHT BULB(S)

- 1** Flex Sides of Light Lens to Remove Lens from Tabs

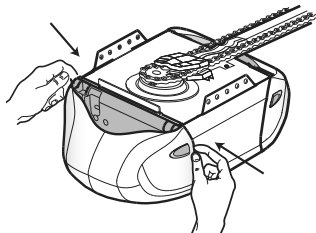

- 2** Rotate Light Lens Down

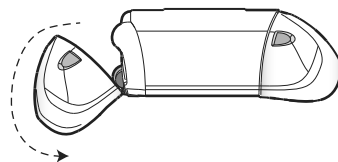

- 3** Install Standard Light Bulb(s) (100W max) into Socket(s)

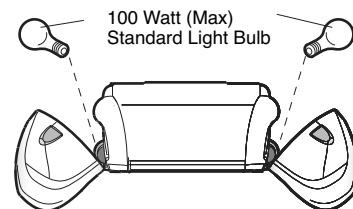

100 Watt (Max)
Standard Light Bulb

ELECTRICAL REQUIREMENTS

- 1** Plug Motor Unit into Power Outlet

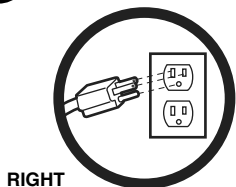

RIGHT

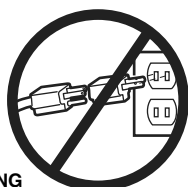

WRONG

NOTE: Plug motor unit into grounded power outlet. If a grounded outlet is not available, contact a qualified electrician to install a proper outlet.

OR

If permanent wiring is required by your local code, follow procedure below. **Disconnect power to the circuit before removing cover to establish permanent wiring connections.**

- 1** Remove Motor Unit Screws and Cover

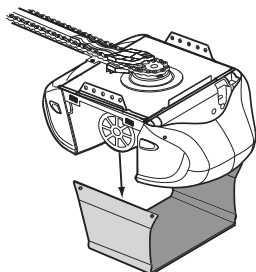

- 2** Remove Power Cord

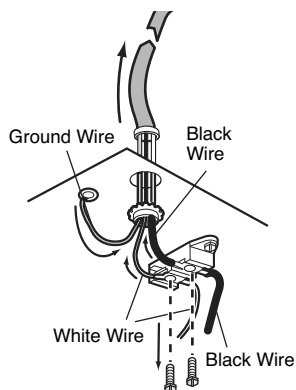

- 3** Run Wire from Outlet to Motor Unit

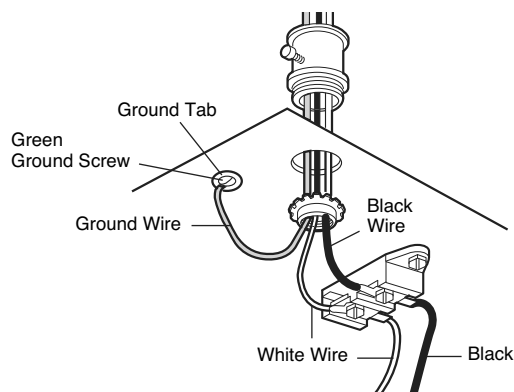

- 4** Replace Motor Unit Cover and Screws

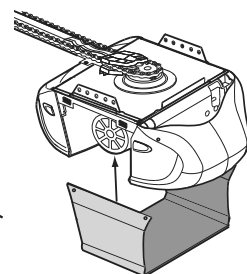

CAUTION

To prevent possible OVERHEATING of the endpanel or light socket:

- DO NOT use short neck or specialty light bulbs.
- DO NOT use halogen bulbs. Use ONLY incandescent.

To prevent damage to the opener:

- DO NOT use bulbs larger than 100W.
- ONLY use A19 size bulbs.

WARNING

To prevent possible SERIOUS INJURY or DEATH from electrocution or fire:

- Be sure power is NOT connected to the opener, and disconnect power to circuit BEFORE removing cover to establish permanent wiring connection.
- Garage door installation and wiring MUST be in compliance with ALL local electrical and building codes.
- NEVER use an extension cord, 2-wire adapter, or change plug in ANY way to make it fit outlet. Be sure the opener is grounded.

⚠ WARNING

To prevent **SERIOUS INJURY** or **DEATH** from a closing garage door:

- Correctly connect and align the safety reversing sensor. This required safety device **MUST NOT** be disabled.
- Install the safety reversing sensor so beam is **NO HIGHER** than 6" (15 cm) above garage floor.

INSTALL THE PROTECTOR SYSTEM®

The safety reversing sensor must be connected and aligned correctly before the garage door opener will move in the down direction.

NOTE: DO NOT operate the opener at this time.

IMPORTANT INFORMATION ABOUT THE SAFETY REVERSING SENSOR

When properly connected and aligned, the sensor will detect an obstacle in the path of its electronic beam. The sending eye (with an amber indicator light) transmits an invisible light beam to the receiving eye (with a green indicator light). If an obstruction breaks the light beam while the door is closing, the door will stop and reverse to full open position, and the opener lights will flash 10 times.

The units must be installed inside the garage so that the sending and receiving eyes face each other across the door, no more than 6" (15 cm) above the floor. Either can be installed on the left or right of the door as long as the sun never shines directly into the receiving eye lens.

The mounting brackets are designed to clip onto the track of sectional garage doors without additional hardware.

If it is necessary to mount the units on the wall, the brackets must be securely fastened to a solid surface such as the wall framing. Extension brackets (see accessories) are available if needed. If installing in masonry construction, add a piece of wood at each location to avoid drilling extra holes in masonry if repositioning is necessary.

The invisible light beam path must be unobstructed. No part of the garage door (or door tracks, springs, hinges, rollers or other hardware) may interrupt the beam while the door is closing.

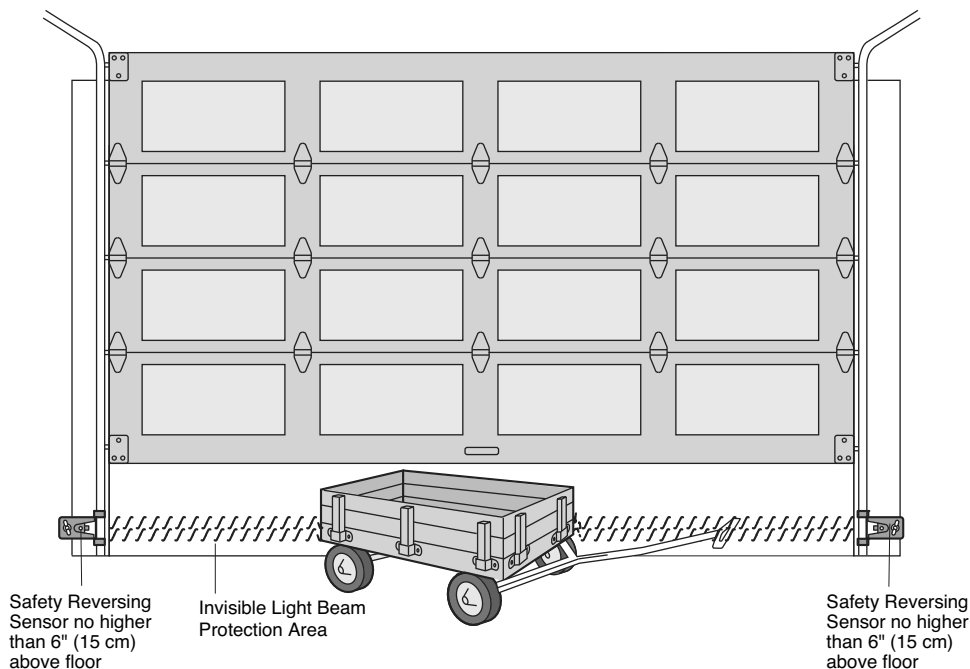

Facing the door from inside the garage

INSTALL THE PROTECTOR SYSTEM®

1 Assemble Safety Reversing Sensors

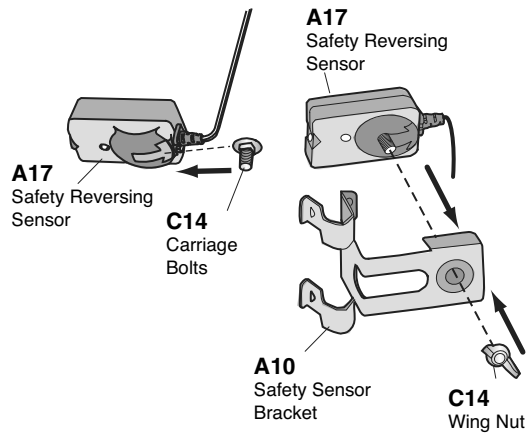

2 Mount Brackets

Garage door track installation (preferred)

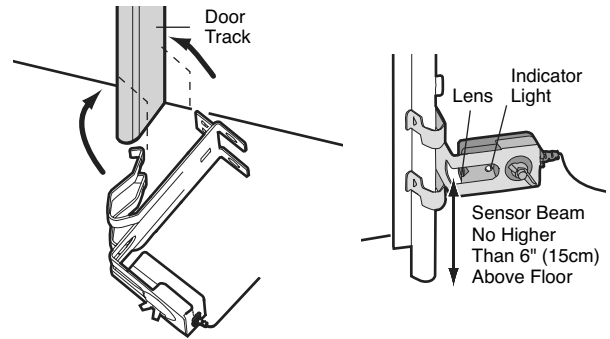

Mount Brackets: Mounting Options

2a Floor installation (optional)

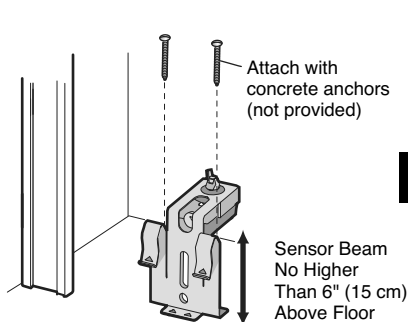

2b Wall installation (optional)

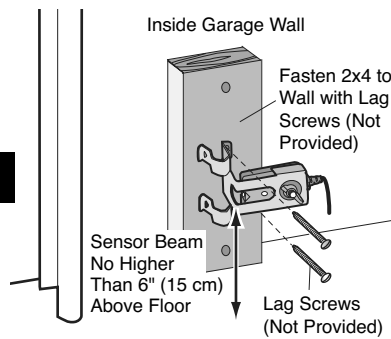

2c Wall installation with Extension Brackets (optional)

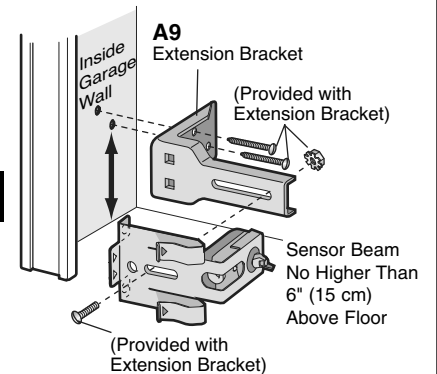

NOTE: The safety reversing sensor must be connected and aligned correctly before the garage door opener will move in the down direction.

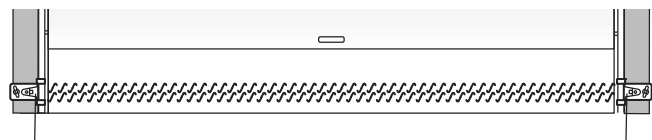

Safety Reversing Sensors MUST be aligned and no higher than 6" (15 cm) above floor

Safety Reversing Sensors MUST be aligned and no higher than 6" (15 cm) above floor

ALL HARDWARE SHOWN ACTUAL SIZE

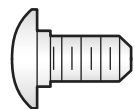

C14 Carriage Bolt



C16 Wing Nut

WIRE SAFETY REVERSING SENSOR

3 Run Safety Sensor Wire to Motor Unit and Secure with Insulated Staples

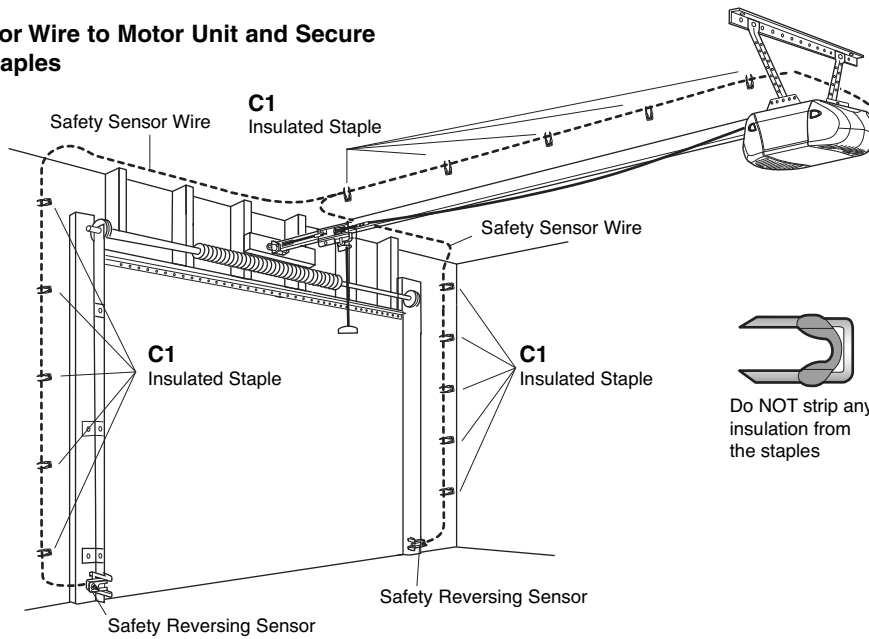

4 Strip All Safety Sensor Wires

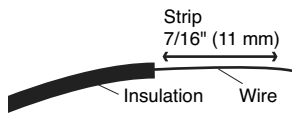

5 Separate the Black/White and the White Wires

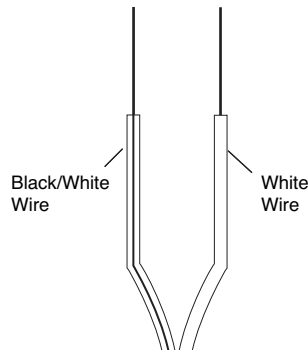

6 Twist Like Colored Wires Together

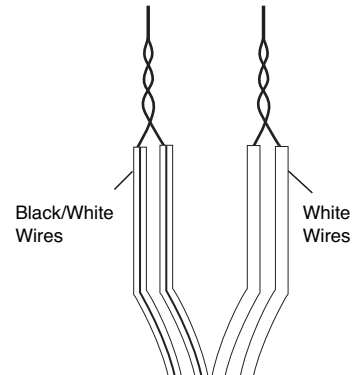

7 Connect Safety Sensors to Motor Unit

Locate the quick connect terminals on your garage door opener, they are located on back panel. Insert the two white wires into the white quick connect terminal and insert the two black/white wires into the grey quick connect terminal

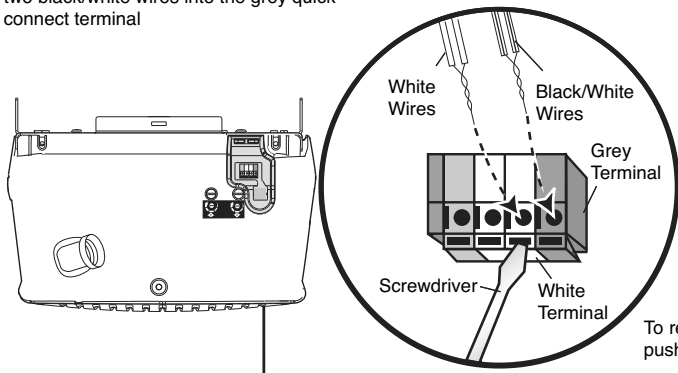

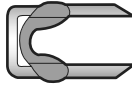

**ALL HARDWARE SHOWN
ACTUAL SIZE**

C1 Staples

To release or insert wire, push in tab with screwdriver.

ADJUSTMENT

ADJUSTMENT STEP 1

ADJUST THE UP AND DOWN TRAVEL LIMITS

Limit adjustment settings regulate the points at which the door will stop when moving up or down.

To operate the opener, press the door control push bar. Run the opener through a complete travel cycle.

- Does the door open and close completely?
- Does the door stay closed and not reverse unintentionally when fully closed?

If your door passes both of these tests, no limit adjustments are necessary unless the reversing test fails (see Adjustment Step 3).

Adjustment procedures are outlined below. Read the procedures carefully before proceeding to Adjustment Step 2. Use a screwdriver to make limit adjustments. Run the opener through a complete travel cycle after each adjustment.

NOTE: Repeated operation of the opener during adjustment procedures may cause the motor to overheat and shut off. Simply wait 15 minutes and try again.

NOTE: If anything interferes with the door's upward travel, it will stop. If anything interferes with the door's downward travel (including binding or unbalanced doors), it will reverse.

HOW AND WHEN TO ADJUST THE LIMITS

- **If the door does not open completely but opens at least 5 feet (1.5 m):**

Increase up travel. Turn the UP limit adjustment screw clockwise. One turn equals 2" (5 cm) of travel.

NOTE: To prevent the trolley from hitting the cover protection bolt, keep a minimum distance of 2-4" (5-10 cm) between the trolley and the bolt.

- **If door does not open at least 5 feet (1.5 m):**
Adjust the UP (open) force as explained in Adjustment Step 2.
- **If the door does not close completely:**
Increase down travel. Turn the DOWN limit adjustment screw counterclockwise. One turn equals 2" (5 cm) of travel.

WARNING

Without a properly installed safety reversal system, persons (particularly small children) could be SERIOUSLY INJURED or KILLED by a closing garage door.

- Incorrect adjustment of garage door travel limits will interfere with proper operation of safety reversal system.
- If one control (force or travel limits) is adjusted, the other control may also need adjustment.
- After ANY adjustments are made, the safety reversal system must be tested. Door must reverse on contact with 1-1/2" (3.8 cm) high object (or 2 x 4 laid flat) on floor.

CAUTION

To prevent damage to vehicles, be sure fully open door provides adequate clearance.

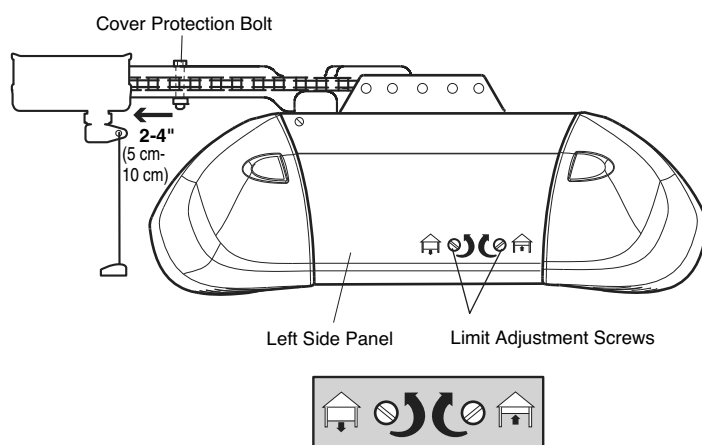

ADJUSTMENT LABEL

Turn either limit adjustment screw the direction of the arrow to increase trolley travel, turn in the opposite direction to decrease travel

- **If the opener reverses in fully closed position:**
Decrease down travel. Turn the DOWN limit adjustment screw clockwise. One turn equals 2" (5 cm) of travel.
- **If the door reverses when closing and there is no visible interference to travel cycle:**
If the opener lights are flashing, the Safety Reversing Sensors are either not installed, misaligned, or obstructed.

ADJUSTMENT STEP 2

ADJUST THE FORCES

Force adjustment controls are located on the back panel of the motor unit. Force adjustment settings regulate the amount of power required to open and close the door.

If the forces are set too light, door travel may be interrupted by nuisance reversals in the down direction and stops in the up direction. Weather conditions can affect the door movement, so occasional adjustment may be needed.

The maximum force adjustment range is about 3/4 of a complete turn. Do not force controls beyond that point. Turn force adjustment controls with a screwdriver.

NOTE: If anything interferes with the door's upward travel, it will stop. If anything interferes with the door's downward travel (including binding or unbalanced doors), it will reverse.

HOW AND WHEN TO ADJUST THE FORCES

1. Test the DOWN (close) force

- Grasp the door bottom when the door is about halfway through DOWN (close) travel. The door should reverse. Reversal halfway through down travel does not guarantee reversal on a 1-1/2" (3.8 cm) obstruction. See *Adjustment Step 3, page 22*. **If the door is hard to hold or doesn't reverse**, decrease the DOWN (close) force by turning the control counterclockwise. Make small adjustments until the door reverses normally. After each adjustment, run the opener through a complete cycle.
- **If the door reverses during the down (close) cycle and the opener lights aren't flashing**, increase DOWN (close) force by turning the control clockwise. Make small adjustments until the door completes a close cycle. After each adjustment, run the opener through a complete travel cycle. Do not increase the force beyond the minimum amount required to close the door.

2. Test the UP (open) force

- Grasp the door bottom when the door is about halfway through UP (open) travel. The door should stop. **If the door is hard to hold or doesn't stop**, decrease UP (open) force by turning the control counterclockwise. Make small adjustments until the door stops easily and opens fully. After each adjustment, run the opener through a complete travel cycle.
- **If the door doesn't open at least 5 feet (1.5 m)**, increase UP (open) force by turning the control clockwise. Make small adjustments until door opens completely. Readjust the UP limit if necessary. After each adjustment, run the opener through a complete travel cycle.

! WARNING

Without a properly installed safety reversal system, persons (particularly small children) could be SERIOUSLY INJURED or KILLED by a closing garage door.

- Too much force on garage door will interfere with proper operation of safety reversal system.
- NEVER increase force beyond minimum amount required to close garage door.
- NEVER use force adjustments to compensate for a binding or sticking garage door.
- If one control (force or travel limits) is adjusted, the other control may also need adjustment.
- After ANY adjustments are made, the safety reversal system must be tested. Door must reverse on contact with 1-1/2" (3.8 cm) high object (or 2 x 4 laid flat) on floor.

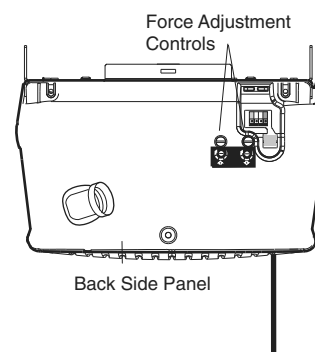

FORCE ADJUSTMENT LABEL

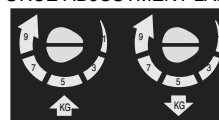

Open Force Close Force

Force Settings:
1 = Lowest Force
9 = Maximum Force

ADJUSTMENT STEP 3

TEST THE SAFETY REVERSAL SYSTEM

Test

- With the door fully open, place a 1-1/2" (3.8 cm) board (or a 2 x 4 laid flat) on the floor, centered under the garage door.
- Operate the door in the down direction. The door must reverse on striking the obstruction.

Adjust

- If the door stops on the obstruction, it is not traveling far enough in the down direction. Increase the down travel by turning the DOWN limit adjustment screw counterclockwise 1/4 turn.

NOTE: On a sectional door, make sure limit adjustments do not force the door arm beyond a straight up and down position. See page 14.

- Repeat the test.
- When the door reverses on the 1-1/2" (3.8cm) (or a 2x4 laid flat) board, remove the obstruction and run the opener through 3 or 4 complete travel cycles to test adjustment.

TEST THE PROTECTOR SYSTEM®

- Press the remote control push button to open the door.
- Place the opener carton in the path of the door.
- Press the remote control push button to close the door. The door will not move more than an inch, and the opener lights will flash.

The garage door opener will not close from a remote if the indicator light in either sensor is off (alerting you to the fact that the sensor is misaligned or obstructed).

If the opener closes the door when the safety reversing sensor is obstructed (and the sensors are no more than 6" (25 mm) above the floor), call for a trained door systems technician.

⚠ WARNING

Without a properly installed safety reversal system, persons (particularly small children) could be SERIOUSLY INJURED or KILLED by a closing garage door.

- Safety reversal system MUST be tested every month.
- If one control (force or travel limits) is adjusted, the other control may also need adjustment.
- After ANY adjustments are made, the safety reversal system must be tested. Door must reverse on contact with 1-1/2" (3.8 cm) high object (or 2 x 4 laid flat) on the floor.

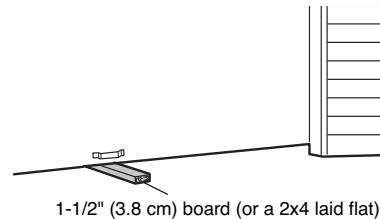

⚠ WARNING

Without a properly installed safety reversing sensor, persons (particularly small children) could be SERIOUSLY INJURED or KILLED by a closing garage door.

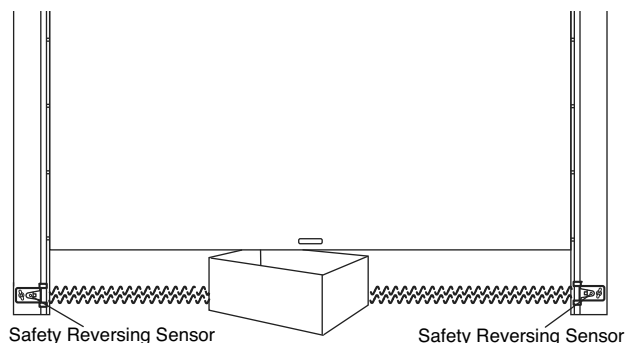

OPERATION

IMPORTANT SAFETY INSTRUCTIONS

WARNING

To reduce the risk of SEVERE INJURY or DEATH:

1. READ AND FOLLOW ALL WARNINGS AND INSTRUCTIONS.
2. ALWAYS keep remote controls out of reach of children. NEVER permit children to operate or play with garage door control push buttons or remote controls.
3. ONLY activate garage door when it can be seen clearly, it is properly adjusted, and there are no obstructions to door travel.
4. ALWAYS keep garage door in sight until completely closed. NO ONE SHOULD CROSS THE PATH OF THE MOVING DOOR.
5. NO ONE SHOULD GO UNDER A STOPPED, PARTIALLY OPEN DOOR.
6. If possible, use emergency release handle to disengage trolley ONLY when garage door is CLOSED. Weak or broken springs or unbalanced door could result in an open door falling rapidly and/or unexpectedly.
7. NEVER use emergency release handle unless garage doorway is clear of persons and obstructions.
8. NEVER use handle to pull garage door open or closed. If rope knot becomes untied, you could fall.
9. If one control (force or travel limits) is adjusted, the other control may also need adjustment.
10. After ANY adjustments are made, the safety reversal system MUST be tested.
11. Safety reversal system MUST be tested every month. Garage door MUST reverse on contact with 1-1/2" (3.8 cm) object (or a 2 x 4 laid flat) on the floor.
12. ALWAYS KEEP GARAGE DOOR PROPERLY BALANCED (see page 2). An improperly balanced door may NOT reverse when required and could result in SEVERE INJURY or DEATH.
13. ALL repairs to cables, spring assemblies and other hardware, ALL of which are under EXTREME tension, MUST be made by a trained door systems technician.
14. ALWAYS disconnect electric power to garage door opener BEFORE making ANY repairs or removing covers.
15. **SAVE THESE INSTRUCTIONS.**

USING YOUR GARAGE DOOR OPENER

Your Security+® opener and hand-held remote control have been factory-set to a matching code which changes with each use, randomly accessing over 100 billion new codes. Your opener will operate with up to eight Security+® remote controls and one Security+® Keyless Entry System. If you purchase a new remote, or if you wish to deactivate any remote, follow the instructions in the Programming section.

Activate your opener with any of the following:

- *The hand-held Remote Control:* Hold the push button down until the door starts to move.
- *The wall-mounted Door Control:* Hold the push button or bar down until the door starts to move.
- *The Keyless Entry (See Accessories):* If provided with your garage door opener, it must be programmed before use. See Programming.

When the opener is activated (with the safety reversing sensor correctly installed and aligned)

1. If open, the door will close. If closed, it will open.
2. If closing, the door will reverse.
3. If opening, the door will stop.
4. If the door has been stopped in a partially open position, it will close.
5. If obstructed while closing, the door will reverse. If the obstruction interrupts the safety sensor beam, the opener lights will blink for five seconds.

6. If obstructed while opening, the door will stop.
7. If fully open, the door will not close when the safety sensor beam is broken. The safety sensor has no effect in the opening cycle.

If the safety sensor is not installed, or is misaligned, the door won't close from a hand-held remote. However, you can close the door with the Door Control, the Outside Keylock, or Keyless Entry, if you activate them until down travel is complete. If you release them too soon, the door will reverse.

The opener lights will turn on under the following conditions: when the opener is initially plugged in; when power is restored after interruption; when the opener is activated.

They will turn off automatically after 4-1/2 minutes or provide constant light when the Light feature on the Multi-Function Door Control is activated. Bulb size is A19. Bulb power is 100 watts maximum.

Security+® light feature: Lights will also turn on when someone walks through the open garage door. With a Multi-Function Door Control, this feature may be turned off as follows: with the opener lights off, press and hold the light button for 10 seconds, until the light goes on, then off again. To restore this feature, start with the opener lights on, then press and hold the light button for 10 seconds until the light goes off, then on again.

USING THE WALL-MOUNTED DOOR CONTROL

The Multi-Function Door Control

Press the push bar/push button to open or close the door. Press again to reverse the door during the closing cycle or to stop the door while it's opening.

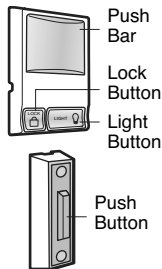

Light Feature

Press the Light button to turn the opener light on or off. It will not control the opener lights when the door is in motion. If you turn it on and then activate the opener, the light will remain on for 4-1/2 minutes. Press again to turn it off sooner. The 4-1/2 minute interval can be changed to 1-1/2, 2-1/2, or 3-1/2 minutes as follows:

1. Press and hold the Lock button until the light blinks (about 10 seconds). A single blink indicates that the timer is reset to 1-1/2 minutes.
2. Repeat the procedure and the light will blink twice, resetting the timer to 2-1/2 minutes.
3. Repeat again for a 3-1/2 minute interval, etc., up to a maximum of four blinks and 4-1/2 minutes.

Lock Feature

Designed to prevent operation of the door from hand-held remote controls. However, the door will open and close from the Door Control, the Outside Keylock and the Keyless Entry Accessories.

To activate, press and hold the Lock button for 2 seconds. The push bar light will flash as long as the Lock feature is on.

To turn off, press and hold the Lock button again for 2 seconds. The push bar light will stop flashing. The Lock feature will also turn off whenever the "Learn" button on the motor unit panel is activated.

TO OPEN THE DOOR MANUALLY

Disconnect the trolley:

The door should be fully closed if possible. Pull down on the emergency release handle (so that the trolley release arm snaps into a vertical position) and lift the door manually. The *lockout feature* prevents the trolley from reconnecting automatically, and the door can be raised and lowered manually as often as necessary.

To re-connect the trolley:

Pull the emergency release handle toward the opener at an angle so that the trolley release arm is horizontal. The trolley will reconnect on the next UP or DOWN operation, either manually or by using the door control or remote.

CARE OF YOUR OPENER

Limit and Force Adjustments

Weather conditions may cause some minor changes in door operation requiring some readjustments, particularly during the first year of operation.

Pages 20 and 21 refer to the limit and force adjustments. Only a screwdriver is required. Follow the instructions carefully.

Repeat the safety reverse test (page 22) after any adjustment of limits or forces.

Maintenance Schedule

Once a Month

- Manually operate door. If it is unbalanced or binding, call a trained door systems technician.
- Check to be sure door opens and closes fully. Adjust limits and/or force if necessary.
- Repeat the safety reverse test. Make any necessary adjustments.

Twice a Year

- Check chain tension. Disconnect trolley first. Adjust if necessary.

Once a Year

- Oil door rollers, bearings and hinges. The opener does not require additional lubrication. Do not grease door tracks.



LIMIT CONTROLS



Open Force Close Force
FORCE CONTROLS

WARNING

To prevent possible **SERIOUS INJURY** or **DEATH** from a falling garage door:

- If possible, use emergency release handle to disengage trolley **ONLY** when garage door is **CLOSED**. Weak or broken springs or unbalanced door could result in an open door falling rapidly and/or unexpectedly.
- **NEVER** use emergency release handle unless garage doorway is clear of persons and obstructions.
- **NEVER** use handle to pull door open or closed. If rope knot becomes untied, you could fall.

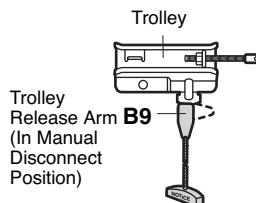

Manual disconnect position

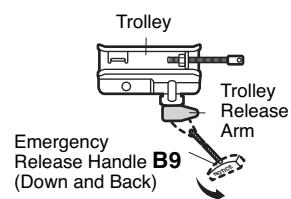

Lockout position

HAVING A PROBLEM?

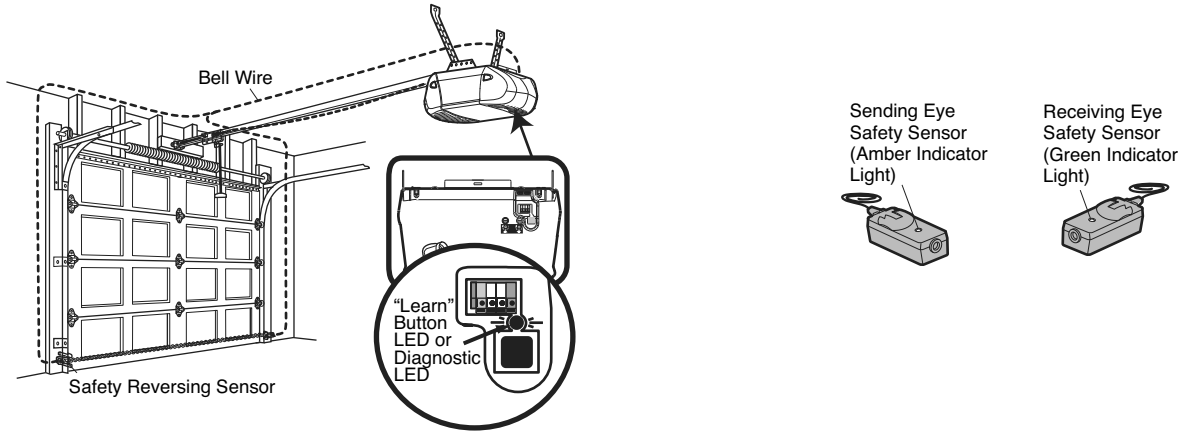

1. My door will not close and the light bulbs blink on my motor unit: The safety reversing sensor must be connected and aligned correctly before the garage door opener will move in the down direction.

- Verify the safety sensors are properly installed, aligned and free of any obstructions. Refer to *Install The Protector System®*.
- Check diagnostic LED for flashes on the motor unit then refer to the Diagnostic Chart on the following page.

2. My remotes will not activate the door:

- Verify your Multi-Function door control is not blinking. If it is blinking, deactivate the Lock Mode following the instructions for *Using the Multi-Function Door Control*.
- Reprogram remotes following the programming instructions. Refer to *Programming*.
- If remote will still not activate your door, check diagnostic LED for flashes on motor unit then refer to *Diagnostic Chart* on the following page.

3. My door reverses for no apparent reason: Repeat safety reverse test after adjustments to force or travel limits. The need for occasional adjustment for the force and limit settings is normal. Weather conditions in particular can affect door travel.

- Manually check door for balance or any binding problems.
- Refer to *Adjust the Forces*.

4. My door reverses for no apparent reason after fully closing and touching the floor: Repeat safety reverse test after adjustments to force or travel limits. The need for occasional adjustment for the force and limit settings is normal. Weather conditions in particular can affect door travel.

- Refer to *Adjust the UP and DOWN Travel Limits*. Decrease down travel by turning DOWN limit adjustment screw clockwise.

5. My lights will not turn off when door is open:

- The garage door opener is equipped with a security light feature. This feature activates the light on when the safety sensor beam has been obstructed. Refer to *Using the Wall Mounted Door Control, Light Feature*.

6. My motor unit hums briefly:

- First verify that the trolley is against the stop bolt.
- Release the door from the opener by pulling the Emergency Release Rope.
- Manually bring the door to a closed position.
- Loosen the chain by adjusting the outer nut 4 to 5 turns. This relieves the tension.
- Run the motor unit from the remote control or door control. The trolley should travel towards the door and stop. If the trolley re-engages with the door, pull the Emergency Release Rope to disengage.
- Decrease the up travel by turning the UP Travel adjustment screw 2 full turns away from the arrow.
- If the trolley does not move away from the bolt, repeat the steps above.

7. My motor unit clicks:

- Motor is overheated. Allow 15 minutes for motor to cool and try again.

DIAGNOSTIC CHART

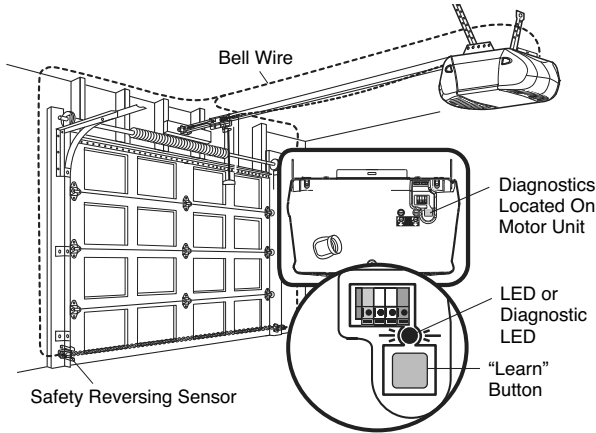

Your garage door opener is programmed with self-diagnostic capabilities. The "Learn" button/diagnostic LED will flash a number of times then pause signifying it has found a potential issue. Consult the Diagnostic Chart below.

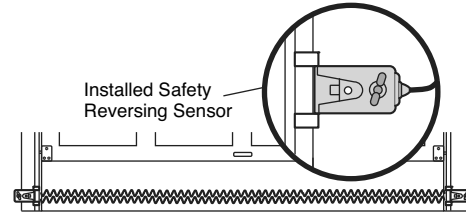

1 FLASH

Safety reversing sensors wire shorted or black/white wire reversed.

OR

2 FLASHES

Safety reversing sensors wire open (broken or disconnected).

3 FLASHES

Door control or wire shorted.

4 FLASHES

Safety Reversing Sensors slightly misaligned (dim or flashing LED).

5 FLASHES

Motor overheated or possible RPM sensor failure. Unplug to reset.

6 FLASHES

Motor Circuit Failure. Replace Receiver Logic Board.

● **Symptom: One or both of the Indicator lights on the safety sensors do not glow steady.**

- Inspect sensor wires for a short (staple in wire), correct wiring polarity (black/white wires reversed), broken or disconnected wires, replace/attach as needed.
- Disconnect all wires from back of motor unit.
- Remove sensors from brackets and shorten sensor wires to 1-2 ft (30-60 cm) from back each of sensor.
- Reattach sending eye to motor unit using shortened wires. If sending eye indicator light glows steadily, attach the receiving eye.
- Align sensors, if the indicator lights glow replace the wires for the sensors. If the sensor indicator lights do not light, replace the safety sensors.

● **Symptom: LED is not lit on door control.**

- Inspect door control/wires for a short (staple in wire), replace as needed.
- Disconnect wires at door control, touch wires together. If motor unit activates, replace door control.
- If motor unit does not activate, disconnect door control wires from motor unit. Momentarily short across red and white terminals with jumper wire. If motor unit activates, replace door control wires.
- If motor unit doesn't operate, motor unit is overheated. Wait 15 minutes and retry. If motor unit still will not operate replace logic board.

● **Symptom: Sending indicator light glows steadily, receiving indicator light is dim or flashing.**

- Realign receiving eye sensor, clean lens and secure brackets.
- Verify door track is firmly secured to wall and does not move.

● **Symptom: Motor has overheated; the motor unit does not operate or trolley is stuck on stop bolt = Motor unit hums briefly; RPM Sensor = Short travel 6-8" (15-20 cm).**

- Unplug unit to reset. Try to operate motor unit, check diagnostic code.
- If it is still flashing 5 times and motor unit moves 6-8" (15-20 cm), replace RPM sensor.

● **Symptom: Motor unit doesn't operate.**

- Replace logic board because motor rarely fails.

PROGRAMMING

TO ADD OR REPROGRAM AN ADDITIONAL HAND-HELD REMOTE CONTROL

NOTICE: If this Security+® garage door opener is operated with a non-rolling code transmitter, the technical measure in the receiver of the garage door opener, which provides security against code-theft devices, will be circumvented. The owner of the copyright in the garage door opener does not authorize the purchaser or supplier of the non-rolling code transmitter to circumvent that technical measure.

Your garage door opener has already been programmed at the factory to operate with your hand-held remote control. The door will open and close when you press the push button.

Below are instructions for programming your opener to operate with additional Security+® remote controls.

Using the “Learn” Button

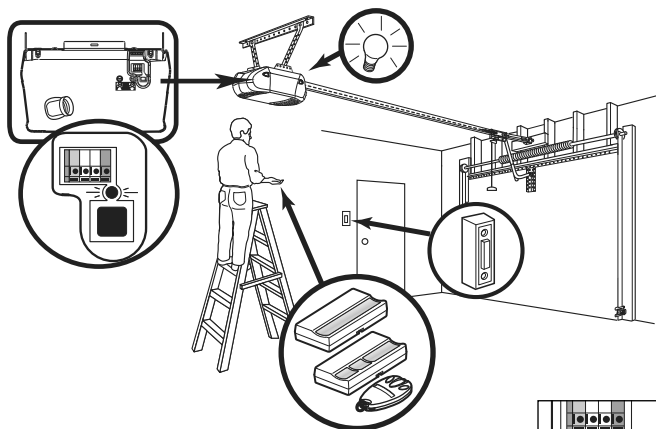

1. Press and release the “learn” button on the motor unit. The learn indicator light will glow steadily for 30 seconds.
2. Within 30 seconds, press and hold the button on the hand-held remote* that you wish to operate your garage door.
3. Release the button when the motor unit lights blink. It has learned the code. If light bulbs are not installed, two clicks will be heard.

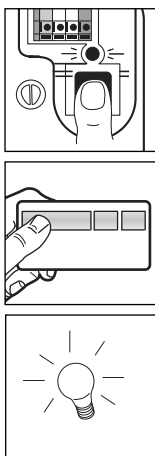

Using the Multi-Function Door Control

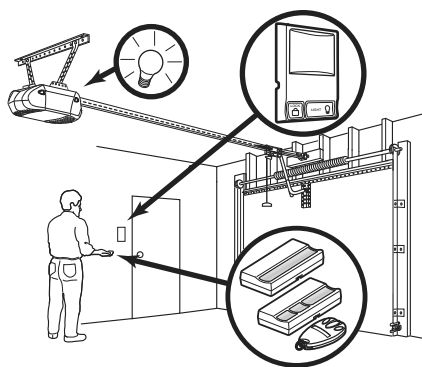

1. Press and hold the button on the hand-held remote* that you wish to operate your garage door.
2. While holding the remote button, press and hold the light button on the Multi-Function Door Control.
3. Continue holding both buttons while you press the push bar on the Multi-Function Door Control (all three buttons are held).
4. Release buttons when the motor unit lights blink. It has learned the code. If light bulbs are not installed, two clicks will be heard.

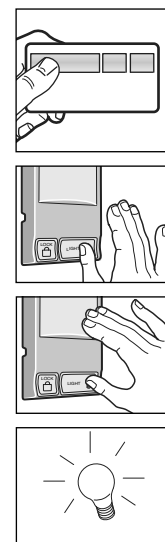

TO CONTROL THE OPENER LIGHTS

Only available with Multi-Function Door Control:

In addition to operating the door, you may program the remote to operate the lights.

1. With the door closed, press and hold a small remote button that you want to control the light.
2. Press and hold the Light button on the Multi-Function door control.
3. While holding the Light button, press and hold the Lock button on the door control.
4. After the opener lights flash, release all buttons.

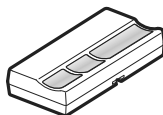

*3-BUTTON REMOTES 315 MHZ

If provided with your garage door opener, the large button is factory programmed to operate it. Additional buttons on any Security+® multi-function remote or mini-remote can be programmed to operate other Security+® garage door openers.

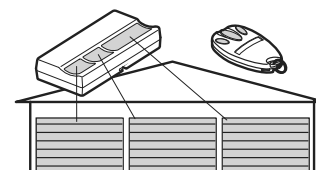

TO ADD, REPROGRAM OR CHANGE A KEYLESS ENTRY PIN

NOTE: Your new Keyless Entry must be programmed to operate your garage door opener.

Using the “Learn” Button

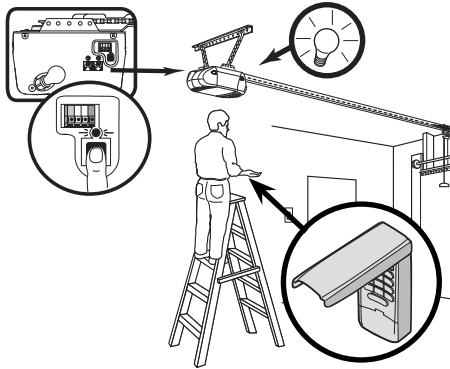

Using the Multi-Function Door Control

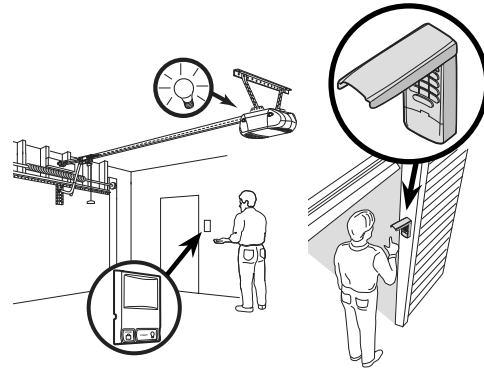

NOTE: This method requires two people if the Keyless Entry is already mounted outside the garage.

1. Press and release the “learn” button on motor unit. The learn indicator light will glow steadily for 30 seconds.
2. Within 30 seconds, enter a four digit personal identification number (PIN) of your choice on the keypad. Then press and hold the enter button.
3. Release the button when the motor unit lights blink. It has learned the code. If light bulbs are not installed, two clicks will be heard.

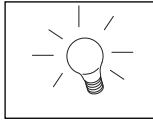
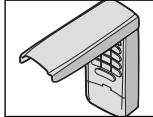
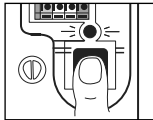

1. Enter a four digit personal identification number (PIN) of your choice on the keypad. Then press and hold enter.
2. While holding the ENTER button, press and hold the LIGHT button on the Multi-Function Door Control.
3. Continue holding the ENTER and LIGHT buttons while you press the push bar on the Multi-Function Door Control (all three buttons are held).
4. Release buttons when the motor unit lights blink. It has learned the code. If light bulbs are not installed, two clicks will be heard.

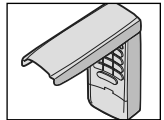

TO CHANGE AN EXISTING, KNOWN PIN

If the existing PIN is known, it may be changed by one person without using a ladder.

1. Press the four buttons for the present PIN, then press and hold the # button.

The opener light will blink twice. Release the # button.

2. Press the new 4-digit PIN you have chosen, then press Enter.

The motor unit lights will blink once when the PIN has been learned.

Test by pressing the new PIN, then press Enter. The door should move.

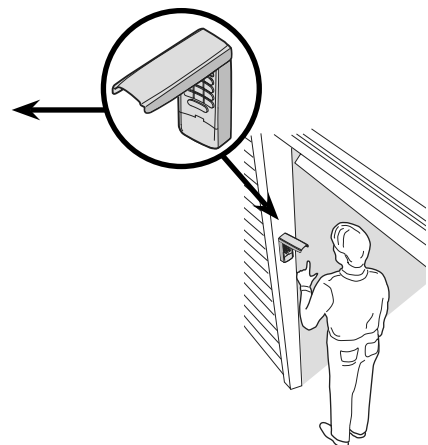
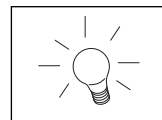
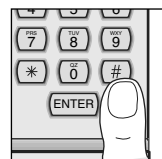

TO SET A TEMPORARY PIN

You may authorize access by visitors or service people with a temporary 4-digit PIN. After a programmed number of hours or number of accesses, this temporary PIN expires and will no longer open the door. It can be used to close the door even after it has expired. To set a temporary PIN:

1. Press the four buttons for your personal entry PIN (not the last temporary PIN), then press and hold the * button.

The opener light will blink three times. Release the button.

2. Press the temporary 4-digit PIN you have chosen, then press Enter.

The opener light will blink four times.

3. To set the number of hours this temporary PIN will work, press the number of hours (up to 255), then press *.

OR

3. To set the number of times this temporary PIN will work, press the number of times (up to 255), then press #.

The opener light will blink once when the temporary PIN has been learned.

Test by pressing the four buttons for the temporary PIN, then press Enter. The door should move. If the temporary PIN was set to a certain number of openings, remember that the test has used up one opening. To clear the temporary password, repeat steps 1-3, setting the number of hours or times to 0 in step 3.

One Button Close: Opener can be closed by pressing only the ENTER button if the one button close feature has been activated. This feature has been activated at the factory. To activate or deactivate this feature press and hold buttons 1 and 9 for 10 seconds. The keypad will blink twice when the one button close is active. The keypad will blink four times when one button close is deactivated.

TO ERASE ALL CODES FROM MOTOR UNIT MEMORY

To deactivate any unwanted remote, first erase all codes: Press and hold the "learn" button on motor unit until the learn indicator light goes out (approximately 6 seconds). All previous codes are now erased. Reprogram each remote or keyless entry you wish to use.

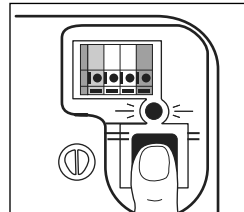

THE REMOTE CONTROL BATTERY

To replace battery, use the visor clip or screwdriver blade to pry open the case as shown. Insert battery positive side up (+).

Dispose of old battery properly.

Replace the battery with only 3V2032 coin cell batteries.

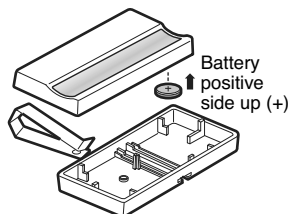

! WARNING

To prevent possible SERIOUS INJURY or DEATH:

- NEVER allow small children near batteries.
- If battery is swallowed, immediately notify doctor.

To reduce risk of fire, explosion or chemical burn:

- Replace ONLY with 3V2032 coin batteries.
- Do NOT recharge, disassemble, heat above 100°C (212°F) or incinerate.

NOTICE: To comply with FCC and or Industry Canada (IC) rules, adjustment or modifications of this receiver and/or transmitter are prohibited, except for changing the code setting or replacing the battery. THERE ARE NO OTHER USER SERVICEABLE PARTS.

Tested to Comply with FCC Standards FOR HOME OR OFFICE USE. Operation is subject to the following two conditions: (1) this device may not cause harmful interference, and (2) this device must accept any interference received, including interference that may cause undesired operation.

REPAIR PARTS

RAIL ASSEMBLY PARTS

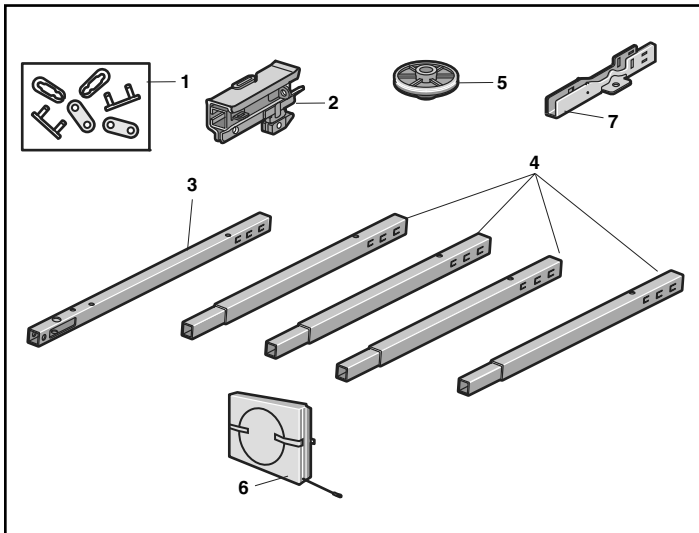

KEY NO.	PART NO.	DESCRIPTION
1	4A1008	Master link kit
2	41C5141-1	Complete trolley assembly
3	183C158-13	Rail - front (header) section
4	183C157-9	Rail - center/back section
5	144C56	Chain idler pulley
6	41A5807	Chain and cable
7	12D598-1	"U" bracket
NOT SHOWN		
	183A163	Wear pads
	19A47	Cover protection bolt spacer

INSTALLATION PARTS

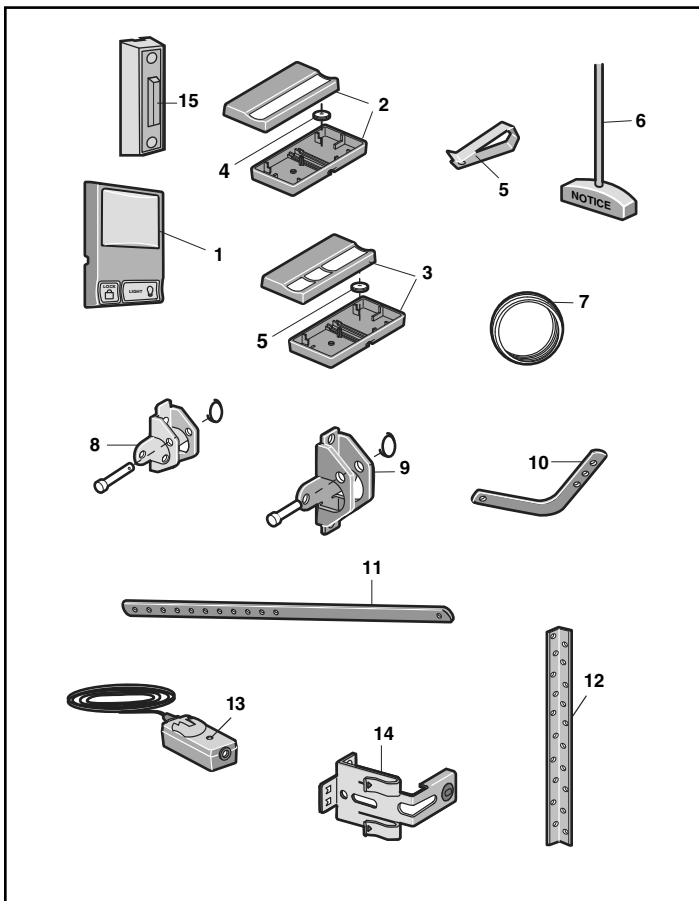

KEY NO.	PART NO.	DESCRIPTION
1	41C494-2	Multi-function door control panel
2	950D	Single-button remote control
3	953D	3-button remote control
4	10A20	3V2032 Lithium battery
5	29B137	Remote control visor clip
6	41A2828	Emergency release rope and handle assembly
7	41B4494-1	2-conductor bell wire – white and white/red
8	41A5047-2	Header bracket with clevis pin and fastener
9	41A5047-1	Door bracket with clevis pin and fastener
10	178B35	Curved door arm section
11	178B34	Straight door arm section
12	12B776	Hanging bracket
13	41A5034	Safety sensor kit (receiving and sending eyes) with 3' (.9 m) 2-conductor bell wire attached
14	41A5266-1	Safety sensor brackets (2)
15	41A4166	Door Control Button
NOT SHOWN		
	41A5258-11	Installation hardware bag
	114A3590	Assembly/installation manual
	114A3163	Installation instructions for one-piece doors

MOTOR UNIT ASSEMBLY PARTS

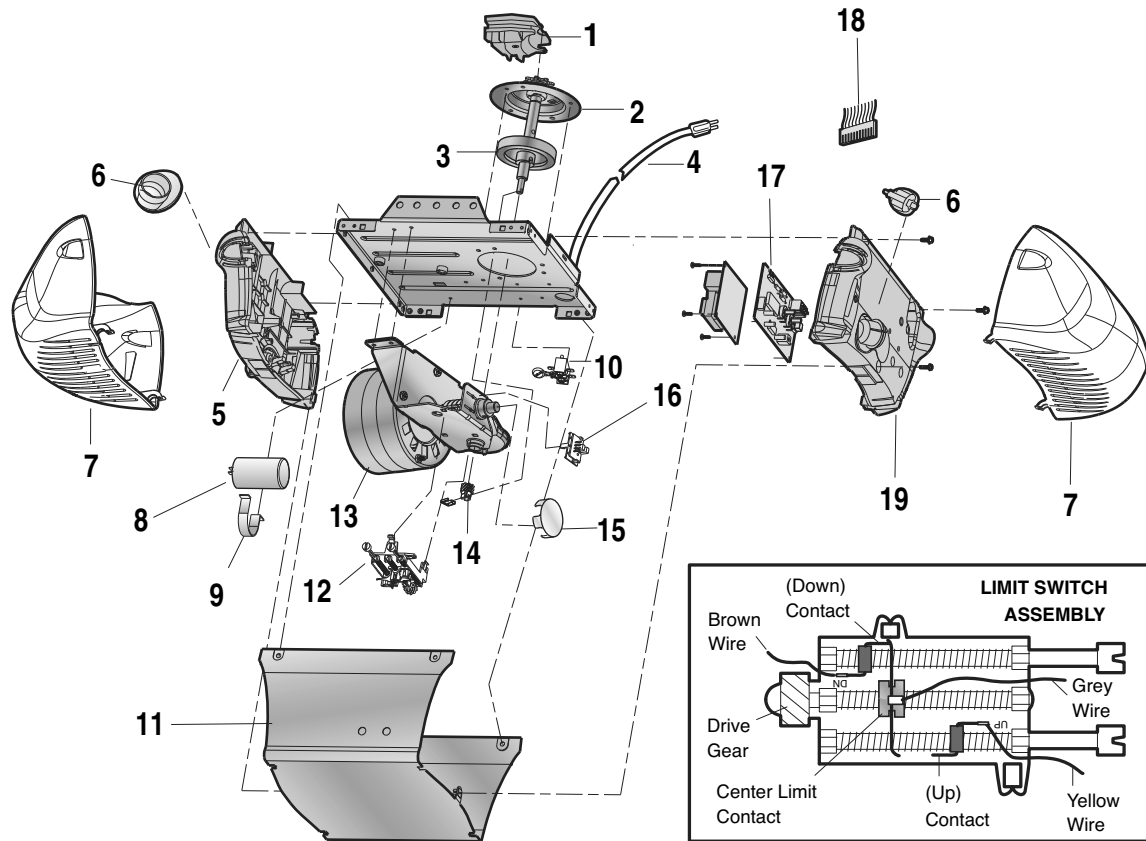

KEY NO.	PART NO.	DESCRIPTION	KEY NO.	PART NO.	DESCRIPTION
1	41A5615	Chain Spreader	13	41D3058	Universal replacement motor and bracket assembly
2	41C4220A	Gear and sprocket assembly Complete with: Spring washer, thrust washer, retaining ring, bearing plate, roll pins (2), drive gear and worm gear, helical gear with retainer and grease	14	41A2818	Limit switch drive and retainer
3	41A2817	Drive/worm gear kit with grease, roll pins (2)	15	41A2822-1	Interrupter cup assembly
4	41B4245	Line cord	16	41C4398A	RPM sensor assembly
5	41A5484-1	End panels with all labels (PD610DM/PD612DM/PD612KLDM/7920KDM/48930DM)	17	41AC050-1M	Receiver logic board assembly (PD210DM/PD212DM/248730M)
	41D181	End panels with all labels (PD210DM/PD212DM/248730M)		41AC050-2M	Receiver logic board assembly (PD610DM/PD612DM/PD612KLDM/7920KDM/48930DM)
6	4A1344	Light socket	18	41C5497	High voltage wire harness assembly
7	108D79	Lens		41C5498	Low voltage wire harness assembly
8	30B532	1/2 hp Capacitor	19	41D180-1	End panels with all labels (PD610DM/PD612DM/PD612KLDM/7920KDM/48930DM)
9	12A373	Capacitor bracket		41A5484-1	End panels with all labels (PD210DM/PD212DM/248730M)
10	41A3150	Terminal block with screws			NOT SHOWN
11	41A5525-5	Cover		41A2826	Motor shaft bearing kit
12	41D3452	Limit switch assembly		41A2825	Opener assembly hardware kit

ACCESSORIES

953D

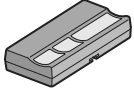

SECURITY+® 3-Button Remote Control Ⓞ:

Includes visor clip.

956D



SECURITY+® 3-Button Mini Remote Control Ⓞ:

With key ring and fastening strip.

935CB



Motion Detecting Control Panel:

Multi-function door control with motion sensor that automatically turns opener lights on for 5 minutes when it detects a person entering the garage. Sensor can be easily deactivated when desired.

945CB

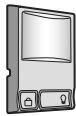

Multi-Function Door Control Panel:

Provides a Lock feature which prevents operation of garage door opener from portable remotes and a Light feature for constant light.

940D

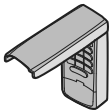

SECURITY+® Keyless Entry Ⓞ:

Enables homeowner to operate garage door opener from outside by entering a password on a specially designed keyboard. Also can add a temporary password for visitors or service persons. This temporary password can be limited to a programmable number of hours or entries.

942FP-10



Fingerprint Keyless Entry Ⓞ:

The system uses biometric technology that enables an authorized user to gain access by scanning their fingerprint. The sensor strip on the unit makes a numeric template of the fingerprint that is unique to that user. The unit's memory can store up to ten fingerprints.

7702CB



Outside Quick Release:

Required for a garage with NO access door.

7708CB

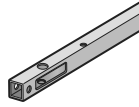

8 Foot (2.4 m) Rail Extension Kit:

To allow an 8 foot (2.4 m) door to open fully.

7710CB

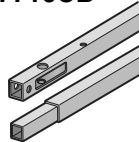

10 foot (3 m) Rail Extension Kit:

To allow a 10 foot (3 m) door to open fully.

41A5281

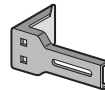

Extension Brackets:

(Optional) For safety sensor installation onto the wall or floor.
To order call: 1-800-528-9131.

WARRANTIES

CHAMBERLAIN 1 YEAR LIMITED WARRANTY 6 YEAR MOTOR LIMITED WARRANTY PD210DM, PD212DM, 7920KDM & 248730M

The Chamberlain Group, Inc. ("Seller") warrants to the first retail purchaser of this product, for the residence in which this product is originally installed, that it is free from defect in materials and/or workmanship for a period of 1 YEAR from the date of purchase and that the MOTOR is free from defect in materials and/or workmanship for a period of 6 YEARS from the date of purchase. The proper operation of this product is dependent on your compliance with the instructions regarding installation, operation, maintenance and testing. Failure to comply strictly with those instructions will void this limited warranty in its entirety.

If, during the limited warranty period, this product appears to contain a defect covered by this limited warranty, call 1-800-528-9131, toll free, before dismantling this product. Then send this product, pre-paid and insured, to our service center for warranty repair. You will be advised of shipping instructions when you call. Please include a brief description of the problem and a dated proof-of-purchase receipt with any product returned for warranty repair. Products returned to Seller for warranty repair, which upon receipt by Seller are confirmed to be defective and covered by this limited warranty, will be repaired or replaced (at Seller's sole option) at no cost to you and returned pre-paid. Defective parts will be repaired or replaced with new or factory-rebuilt parts at Seller's sole option.

ALL IMPLIED WARRANTIES FOR THE PRODUCT, INCLUDING BUT NOT LIMITED TO ANY IMPLIED WARRANTIES OF MERCHANTABILITY AND FITNESS FOR A PARTICULAR PURPOSE, ARE LIMITED IN DURATION TO THE 1 YEAR LIMITED WARRANTY PERIOD SET FORTH ABOVE EXCEPT THE IMPLIED WARRANTIES WITH RESPECT TO THE MOTOR, WHICH ARE LIMITED IN DURATION TO THE 6 YEARS LIMITED WARRANTY PERIOD FOR THE MOTOR, AND NO IMPLIED WARRANTIES WILL EXIST OR APPLY AFTER SUCH PERIOD. Some States do not allow limitations on how long an implied warranty lasts, so the above limitation may not apply to you. **THIS LIMITED WARRANTY DOES NOT COVER NON-DEFECT DAMAGE, DAMAGE CAUSED BY IMPROPER INSTALLATION, OPERATION OR CARE (INCLUDING, BUT NOT LIMITED TO ABUSE, MISUSE, FAILURE TO PROVIDE REASONABLE AND NECESSARY MAINTENANCE, UNAUTHORIZED REPAIRS OR ANY ALTERATIONS TO THIS PRODUCT), LABOR CHARGES FOR REINSTALLING A REPAIRED OR REPLACED UNIT, REPLACEMENT OF BATTERIES AND LIGHT BULBS OR UNITS INSTALLED FOR NON-RESIDENTIAL USE.**

THIS LIMITED WARRANTY DOES NOT COVER ANY PROBLEMS WITH, OR RELATING TO, THE GARAGE DOOR OR GARAGE DOOR HARDWARE, INCLUDING BUT NOT LIMITED TO THE DOOR SPRINGS, DOOR ROLLERS, DOOR ALIGNMENT OR HINGES. THIS LIMITED WARRANTY ALSO DOES NOT COVER ANY PROBLEMS CAUSED BY INTERFERENCE. ANY SERVICE CALL THAT DETERMINES THE PROBLEM HAS BEEN CAUSED BY ANY OF THESE ITEMS COULD RESULT IN A FEE TO YOU.

UNDER NO CIRCUMSTANCES SHALL SELLER BE LIABLE FOR CONSEQUENTIAL, INCIDENTAL OR SPECIAL DAMAGES ARISING IN CONNECTION WITH USE, OR INABILITY TO USE, THIS PRODUCT. IN NO EVENT SHALL SELLER'S LIABILITY FOR BREACH OF WARRANTY, BREACH OF CONTRACT, NEGLIGENCE OR STRICT LIABILITY EXCEED THE COST OF THE PRODUCT COVERED HEREBY. NO PERSON IS AUTHORIZED TO ASSUME FOR US ANY OTHER LIABILITY IN CONNECTION WITH THE SALE OF THIS PRODUCT.

Some states do not allow the exclusion or limitation of consequential, incidental or special damages, so the above limitation or exclusion may not apply to you. This limited warranty gives you specific legal rights, and you may also have other rights which vary from state to state.

CHAMBERLAIN 1 YEAR LIMITED WARRANTY LIFETIME MOTOR LIMITED WARRANTY PD610DM, PD612DM, PD612KLD & 48930DM

The Chamberlain Group, Inc. ("Seller") warrants to the first retail purchaser of this product, for the residence in which this product is originally installed, that it is free from defect in materials and/or workmanship for a period of 1 YEAR from the date of purchase and that the MOTOR is free from defect in materials and/or workmanship for the lifetime of the product. The proper operation of this product is dependent on your compliance with the instructions regarding installation, operation, maintenance and testing. Failure to comply strictly with those instructions will void this limited warranty in its entirety.

If, during the limited warranty period, this product appears to contain a defect covered by this limited warranty, call 1-800-528-9131, toll free, before dismantling this product. Then send this product, pre-paid and insured, to our service center for warranty repair. You will be advised of shipping instructions when you call. Please include a brief description of the problem and a dated proof-of-purchase receipt with any product returned for warranty repair. Products returned to Seller for warranty repair, which upon receipt by Seller are confirmed to be defective and covered by this limited warranty, will be repaired or replaced (at Seller's sole option) at no cost to you and returned pre-paid. Defective parts will be repaired or replaced with new or factory-rebuilt parts at Seller's sole option.

ALL IMPLIED WARRANTIES FOR THE PRODUCT, INCLUDING BUT NOT LIMITED TO ANY IMPLIED WARRANTIES OF MERCHANTABILITY AND FITNESS FOR A PARTICULAR PURPOSE, ARE LIMITED IN DURATION TO THE 1 YEAR LIMITED WARRANTY PERIOD SET FORTH ABOVE EXCEPT THE IMPLIED WARRANTIES WITH RESPECT TO THE MOTOR, WHICH ARE LIMITED IN DURATION TO THE LIFETIME LIMITED WARRANTY PERIOD FOR THE MOTOR, AND NO IMPLIED WARRANTIES WILL EXIST OR APPLY AFTER SUCH PERIOD. Some States do not allow limitations on how long an implied warranty lasts, so the above limitation may not apply to you. **THIS LIMITED WARRANTY DOES NOT COVER NON-DEFECT DAMAGE, DAMAGE CAUSED BY IMPROPER INSTALLATION, OPERATION OR CARE (INCLUDING, BUT NOT LIMITED TO ABUSE, MISUSE, FAILURE TO PROVIDE REASONABLE AND NECESSARY MAINTENANCE, UNAUTHORIZED REPAIRS OR ANY ALTERATIONS TO THIS PRODUCT), LABOR CHARGES FOR REINSTALLING A REPAIRED OR REPLACED UNIT, REPLACEMENT OF BATTERIES AND LIGHT BULBS OR UNITS INSTALLED FOR NON-RESIDENTIAL USE.**

THIS LIMITED WARRANTY DOES NOT COVER ANY PROBLEMS WITH, OR RELATING TO, THE GARAGE DOOR OR GARAGE DOOR HARDWARE, INCLUDING BUT NOT LIMITED TO THE DOOR SPRINGS, DOOR ROLLERS, DOOR ALIGNMENT OR HINGES. THIS LIMITED WARRANTY ALSO DOES NOT COVER ANY PROBLEMS CAUSED BY INTERFERENCE. ANY SERVICE CALL THAT DETERMINES THE PROBLEM HAS BEEN CAUSED BY ANY OF THESE ITEMS COULD RESULT IN A FEE TO YOU.

UNDER NO CIRCUMSTANCES SHALL SELLER BE LIABLE FOR CONSEQUENTIAL, INCIDENTAL OR SPECIAL DAMAGES ARISING IN CONNECTION WITH USE, OR INABILITY TO USE, THIS PRODUCT. IN NO EVENT SHALL SELLER'S LIABILITY FOR BREACH OF WARRANTY, BREACH OF CONTRACT, NEGLIGENCE OR STRICT LIABILITY EXCEED THE COST OF THE PRODUCT COVERED HEREBY. NO PERSON IS AUTHORIZED TO ASSUME FOR US ANY OTHER LIABILITY IN CONNECTION WITH THE SALE OF THIS PRODUCT.

Some states do not allow the exclusion or limitation of consequential, incidental or special damages, so the above limitation or exclusion may not apply to you. This limited warranty gives you specific legal rights, and you may also have other rights which vary from state to state

CHAMBERLAIN® SERVICE IS ON CALL

**OUR LARGE SERVICE ORGANIZATION
SPANS AMERICA**

INSTALLATION AND SERVICE INFORMATION IS AS NEAR AS YOUR TELEPHONE.

SIMPLY DIAL OUR TOLL FREE NUMBER:

1-800-528-9131

www.chamberlain-diy.com

For professional installation, parts and service, contact your local CHAMBERLAIN® dealer. Look for him in the Yellow Pages or call our Service number for a list of dealers in your area.

HOW TO ORDER REPAIR PARTS

Selling prices will be furnished on request, or parts will be shipped at prevailing prices and you will be billed accordingly.

WHEN ORDERING REPAIR PARTS, ALWAYS GIVE THE FOLLOWING INFORMATION:

- **PART NUMBER**
- **PART NAME**
- **MODEL NUMBER**

ADDRESS ORDERS TO:

**THE CHAMBERLAIN GROUP, INC.
Technical Support Group
6050 S. Country Club Road
Tucson, Arizona 85706**

SERVICE INFORMATION TOLL FREE NUMBER:

1-800-528-9131