



Instruction Manual
THE ROBO SLIDE™
RESIDENTIAL SLIDE GATE OPERATOR

installation instructions and manual book
for architects, general contractors and dealers

TABLE OF CONTENTS

Role of Specifiers..., Role of Dealers....	2
Role of End Users/Home Owners, Horizontal Slide Gate Systems	3
Warnings and Precautions	4-6
Safely Operating Gate	7
Important Notice	8
Configuration and Specifications	9
Warnings and Precautions	10
Step 1: Getting Started	10
Step 2: Mounting Operator	11
Step 3: Chain Installation	11
Step 4: Gate Movement Direction	12
Step 5: Earth Ground Rod	13
Step 6: DC Power Supply Connection	14
Step 7: "Optional" Solar Panel	15
Step 8: Surge Suppression Terminal Connections	16
Step 9: Adjusting Gate Travel Distance	17
Step 10: Timer	17
Step 11: 2-Way Adjustable Reversing Sensor	18
Step 12: Mounting Warning Placards	18
"Optional" Fire Release Box	19
"Optional" Input Board	20
Maglock Wiring Connection	21
"Optional" 12 VDC Photocell Wiring	22
3-Push Button Wiring Connection	23
3-Push Button Wiring Master / Slave	24
"Optional" Edge Sensor Wiring	25
Single Operator Loop Size and Placement	26
Master / Slave Loop Size and Placement	27
Loop Installation and Number of Wire Turns	28
Wiring Loop Detector to Operator	29
Master and Slave Operators with Timer	30
Master and Slave Operators without Timer	31
Control Board Functions	32
LED Descriptions	33-34
Troubleshooting	
How to Reset Breaker Switch	35
How to Check Fuses	35
Gate will not close!	36
Gate will not open!	36
If you hear a "BEEP" sound (Audio Alarm)	37
Robo Slide Parts	38
Robo Slide Parts List	39
Elite Robo Slide Accessories	40
Owners Checklist of Installation	41



© COPYRIGHT 1992-2003 BY ELITE ACCESS SYSTEMS, INC.
 All rights reserved. No part of this manual may be reproduced in any means; graphic, electronic, mechanical, or photocopied without the express written permission of the publisher of this material.

Release 7
7/03

For Toll Free Technical Support: **1-888-ELITE-10**
35483

ROLE OF SPECIFIERS AND DESIGNERS

Specifiers and designers should design an automatic vehicular gate system to:

- Utilize an operator suited for gate system type, size, frequency of use, location and user population.
- Separate pedestrian access from vehicle access.
- Reduce or eliminate pinch points.
- Reduce risk of entrapment injuries by minimizing all gaps in the gate and enclosing the area of the travel of the gate.
- Secure controls from unauthorized use.
- Locate all controls out of reach from the gate.
- Allow the user full view of the gate when operating.
- Consider special populations, such as children or the elderly.
- Be consistent with DASMA's Automatic Gate Opener System Safety Guide.

ROLE OF DEALERS, INSTALLERS AND TRAINED GATE SYSTEM TECHNICIANS

Installers, during the course of the installation proceedings for each job, should:

- Confirm that the gate operator being installed is appropriate for the application.
- Confirm that the gate is designed and built according to current published industry standards.
- Confirm that all appropriate features and accessory devices are being incorporated, including both primary and secondary entrapment protection devices.
- Make sure that the gate works freely before installing the operator.
- Repair or service worn or damaged gate hardware before installing the operator.
- Eliminate all gaps in the sliding gate below a 4 foot height that permit a 2 1/4 inch sphere to pass through any location, including the area of the adjacent fence covered when the gate is in the open position.
- Install the gate operator according to the manufacturer's installation instructions.
- Adjust the operator clutch or load-sensing device to the minimum force setting that allows reliable gate operation.
- Install operator inside fence line (DO NOT install operator on public side of fence line)
- Install a proper electrical ground to a gate operator.
- Install keypad controls where users cannot touch, or reach through gate while operating controls.
- Install controls where user has full view of gate operation.
- Test all features for proper functions before placing the automatic vehicular gate into service.
- Demonstrate the basic functions and safety features of the gate system to owners/end users/general contractors, including how to turn off power and how to operate the manual disconnect feature.
- Leave safety instructions, product literature, installation manual and maintenance manual with end user.
- Explain to the owners the importance of a service contract that includes a routine re-testing of the entire system including the entrapment protection devices, and explain the need for the owners to insure that this testing is performed routinely.
- Offer the owner/end user a maintenance contract, or contact them regularly to offer maintenance.

ROLE OF END USERS/HOME OWNER

End users should be made aware that they must:

- Contact a trained gate systems technician to maintain and repair the gate system (End users should never attempt to repair the gate)
- Retain and utilize the installation and maintenance manual and safety instructions.
- Routinely check of all gate operator functions and gate movement.
- Discontinue use if safety systems operate improperly, the gate is damaged, or the gate is difficult to move.
- Never overtighten the operator clutch of load sensing device to compensate for a damaged or stiff operating gate.
- Keep all obstructions clear of the vicinity of the path of the gate system.
- Actively discourage pedestrian use of the vehicular gate operating system.
- Prevent anyone from playing near any part of the gate system.
- Never allow anyone to climb under, over or through a gate or the adjacent fence area.
- Never allow children to operate gate
- Keep portable controls out of reach of children.
- Never allow anyone to install an operating control within reach of the gate.
- Never allow anyone to install a horizontal slide gate with exposed rollers or openings large enough to allow a sphere of 2 1/4 inches to pass through any portion of the gate below a 4 foot height, including the area of the adjacent fence covered when the gate is in the open position.
- Always be certain that the gate area is clear of pedestrians before operating the gate.

HORIZONTAL SLIDE GATE SYSTEMS

- **Entrapment Zone Hazard** - Body parts may become entrapped between a gate and a stationary object when the gate begins to move, which can result in serious injury or death. Pedestrians must stay clear of the gate path, and any area where gate motion is close to stationary objects.
- **Pinch Points Hazard** - In open rollers gates, hands can get caught between the top of the gate and top rollers, which can result in serious injury. Feet can be injured in the same manner between the bottom of the gate and bottom rollers. Covers to guard these pinch points should be installed.
- **Crush Hazard** - In picket gates, body parts positioned between the bars can become seriously mutilated when the gate begins to move, which can result in serious injury or death. If any openings are greater than 2 1/4 inches, a screen should be installed over the gate (in accordance with the provisions of UL 325) to prevent persons from reaching through and/or passing through the gate. In like manner, screening should also be applied to the adjacent fence area covered by the gate when in the fully open position.

WARNINGS AND PRECAUTIONS

IMPORTANT!

Instructions regarding Robo Slide Installation.

- A)** Install the gate operator only when:
- 1)** All openings of a horizontal slide gate are guarded or screened from the bottom of the gate to a minimum of 4 feet (1.2 m) above the ground to prevent a 2 1/4inch (57.15 mm) diameter sphere from passing through the openings anywhere in the gate, and in that portion of the adjacent fence that the gate covers in the open position.
 - 2)** All exposed pinch points are eliminated or guarded, and
 - 3)** Guarding is supplied for exposed rollers.
- B)** ***The operator is intended for installation only on gates used for vehicles. Pedestrians must be supplied with a separate access opening.***
- C)** The gate must be installed in a location so that enough clearance is supplied between the gate and adjacent structures when opening and closing to reduce the risk of entrapment.
- D)** The gate must be properly installed and work freely in both directions prior to the installation of the gate operator.
- E)** Controls must be far enough from the gate so that the user is prevented from coming in contact with the gate while operating the controls.

WARNINGS AND PRECAUTIONS

- F)** For a gate operator utilizing a non-contact sensor such as a photo beam:
- 1)** See instructions on the placement of non-contact sensor for each type of application.
 - 2)** Care shall be exercised to reduce the risk of nuisance tripping, such as when a vehicle trips the sensor while the gate is still moving.
 - 3)** One or more non-contact sensors shall be located where the risk of entrapment or obstruction exists, such as the perimeter reachable by a moving gate or barrier.
- G)** For a gate operator utilizing a contact sensor such as an edge sensor:
- 1)** One or more contact sensors shall be located at the leading edge, trailing edge and postmounted both inside and outside of a vehicular horizontal slide gate.
 - 2)** A hardwired contact sensor shall be located and its wiring arranged so that the communication between the sensor and the gate operator is not subjected to mechanical damage.
 - 3)** A wireless contact sensor such as the one that transmits radio frequency (RF) signals to the gate operator for entrapment protection functions shall be located where the transmission of the signals are not obstructed or impeded by building structures, natural landscaping or similar obstruction. A wireless contact sensor shall function under the intended end-use conditions.

WARNINGS AND PRECAUTIONS

IMPORTANT SAFETY INSTRUCTIONS

WARNING - *To reduce the risk of Injury or Death:*

- 1. READ AND FOLLOW ALL INSTRUCTIONS.**
- 2. *Never*** let children operate or play with gate controls. Keep the remote control away from children.
- 3. *Always keep people and objects away from the gate.***
NO ONE SHOULD CROSS THE PATH OF THE MOVING GATE!
- 4.** Test the gate operator monthly. The gate ***MUST*** reverse on contact with a rigid object or stop when an object activates the non-contact sensors. After adjusting the force or the limit of travel, retest the gate operator, Failure to adjust and retest the gate operator properly can increase the risk of injury or death.
- 5. *KEEP GATES PROPERLY MAINTAINED.*** Read the manual. Have a qualified service person make repairs to the gate or gate hardware.
- 6. *The entrance is for vehicles only. Pedestrians must use separate entrance.***
- 7. *SAVE THESE INSTRUCTIONS.***

SAFELY OPERATING GATE

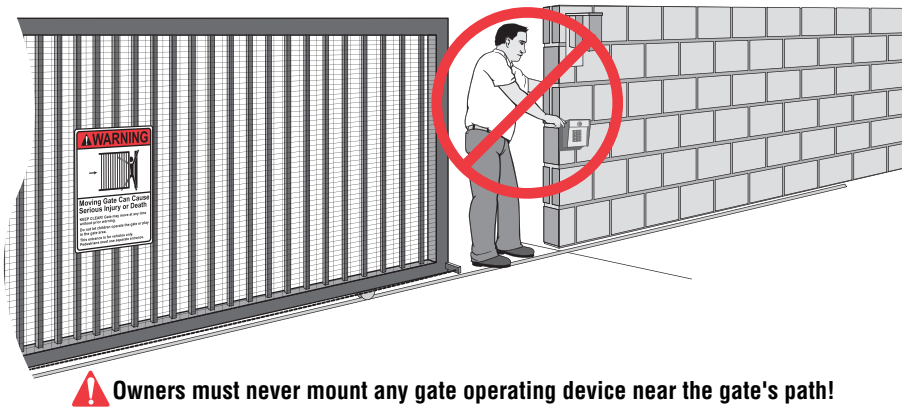

IMPORTANT NOTICE

IMPORTANT! Because the coasting distance may vary due to changes in temperature, Elite does **NOT** recommend the installation of a stop or catch post in front of the gates path. To do so will cause the gate to hit the post in certain instances.

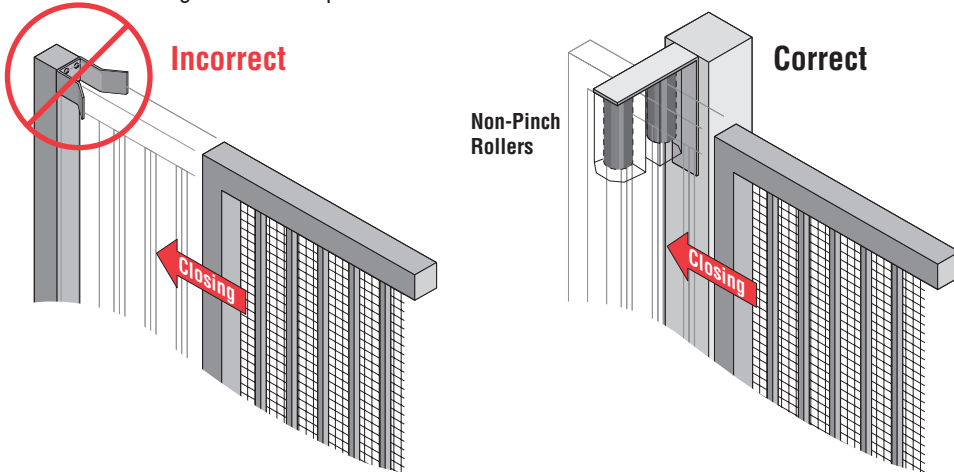

Elite only recommends installation of catch rollers on the side of a catch post or wall with a minimal distance of half an inch between the rollers and gate. Also when fully open the end of the sliding gate must stop at least five inches from a wall.

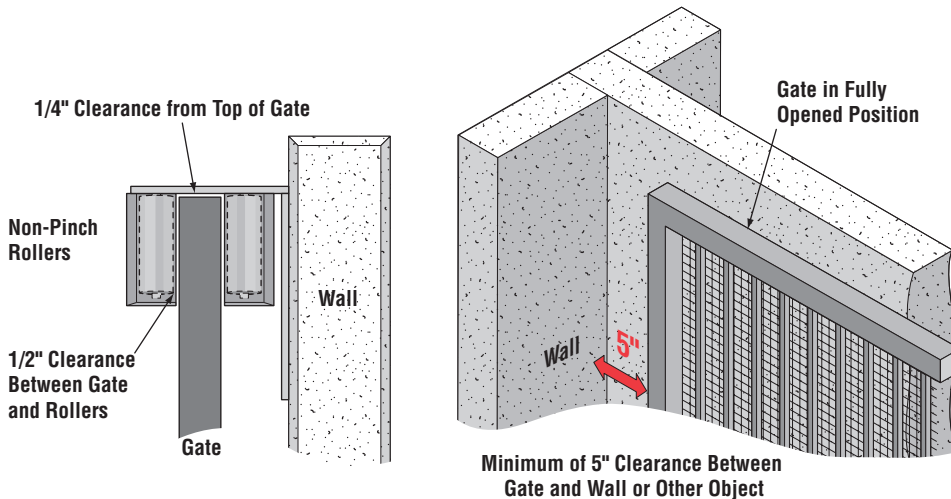

For safety reasons, a physical stop **MUST** be installed on the gate prior to installation of the gate operator. This will assure that the gate does not exceed movement limits and derail while opening or closing fully.

CONFIGURATION AND SPECIFICATIONS

All “Pinch Points” **MUST** have protective safety devices.

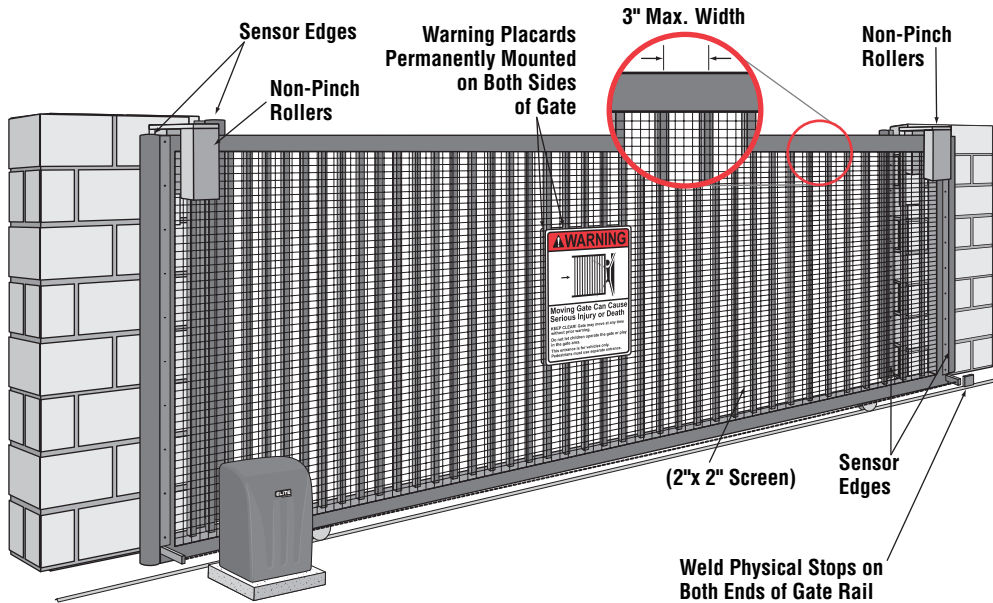

Recommended Gate Setup Configuration

Robo Slide Specifications:

Gate Speed – 11 inch per second

Maximum Gate Length – 20 feet

Maximum Gate Weight – 800 pounds

Maximum Cycles – 70 cycles per day with Elite's Plug-In Transformer.

– Solar power cycles per day varies, Contact Elite for more Information

– Battery back-up cycles (50 cycles total)

AC Power Supply – 18 VAC 2.0 Amp Plug-In Transformer (Elite Part # **A POW-1**)

AC Power Supply Wire – 14 gauge or greater landscape lighting cable rated for direct burial and 300 watts at maximum length of 1000 ft

DC Power Supply – Built-in, back-up for AC or Solar power failure only

Solar Power – Optional (Elite Part # **SOLAR 3**)



Be sure to read and follow all Elite's instructions before installing and operating any Elite product. Always disconnect the gate operator's power source before repairs are attempted. Elite Access Systems, Inc. is not responsible for improper installation or failure to comply with local building codes.

READ ENTIRE OWNERS MANUAL BEFORE INSTALLATION

Model:

Robo Slide

For Single Home Applications.

DO NOT Use for Apartment or Condominium Applications.

Warnings and Precautions



1. Do not tighten chain too tight
2. Use proper type of wheels - only 4" steel wheels with high speed ball bearings
3. Do not use a 12V transformer - use only 18 VAC 2.0 Amp
4. Do not install as a rear-mount installation
5. Use only 14 gauge or greater landscape lighting cable rated for direct burial and 300 watts



STEP 1: Getting Started

This gate operator is designed for single home application, or for limited commercial applications. An example of a commercial application would be a factory facility with limited cycles per day, using a plug in transformer or solar panel.

STEP BY STEP INSTALLATION

STEP 2: Mounting Operator

Pour concrete bed for Robo Slide. Minimum size of bed is 20" x 15" x 20"d. Suggested installation for bolts is 1/2" x 3 1/2" (for red-head fastener).

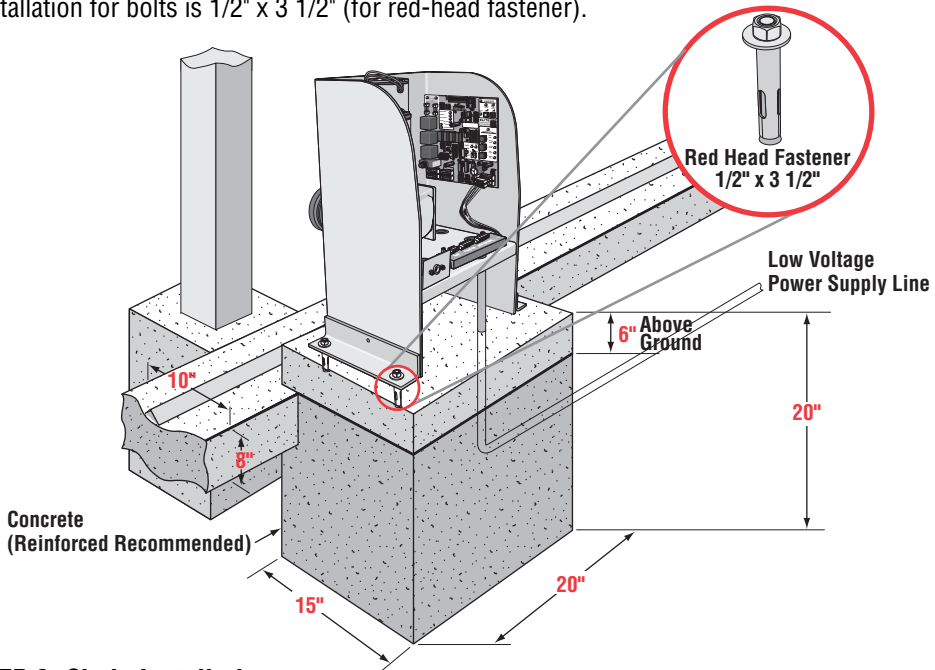

STEP 3: Chain Installation

Minimum space between gate and output sprocket must be 4". After you position the gate operator, bolt-down the operator to the concrete bed. Make certain that the concrete bed is solid.

Correct Chain Installation

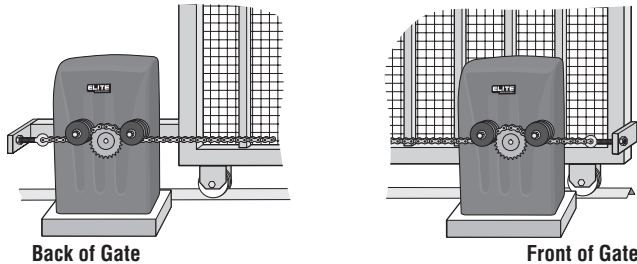

Incorrect Chain Installation

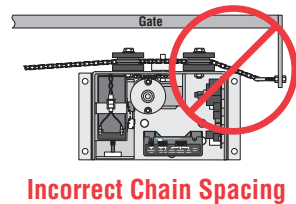
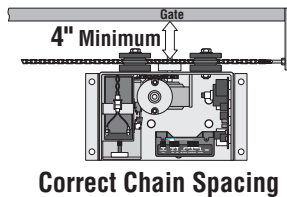
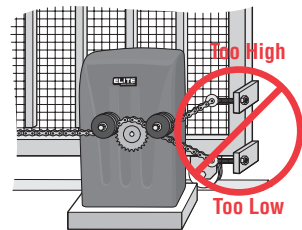

STEP BY STEP INSTALLATION

STEP 4: Gate Movement Direction

Plug in the motor harness wires to the left (**Socket 1**) if your gate, from the inside of the property, opens to the left. Plug into the right (**Socket 2**) if the gate opens to the right.

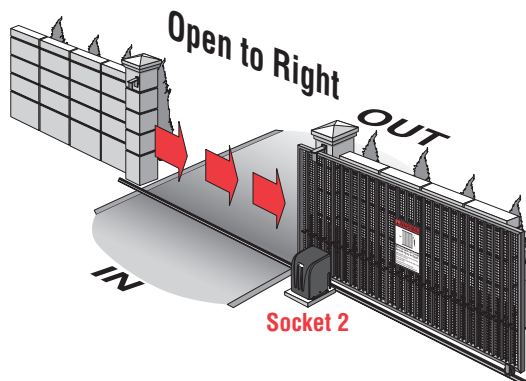
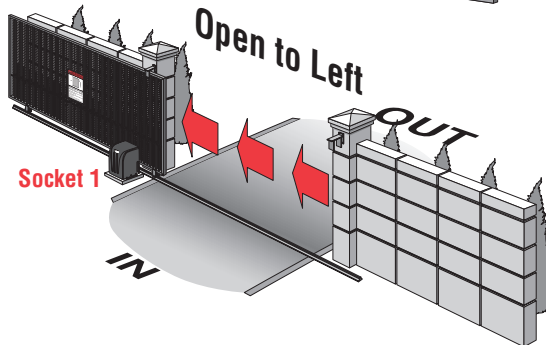
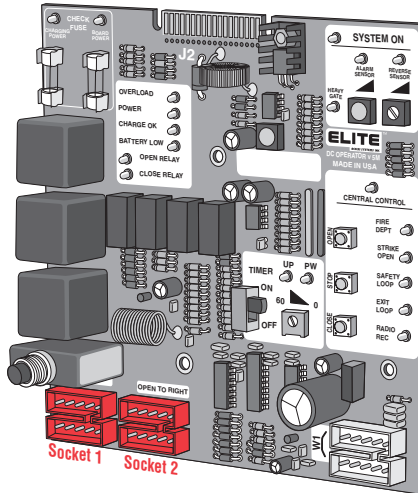

STEP BY STEP INSTALLATION

STEP 5: Earth Ground Rod Installation

⚠ An earth ground rod must be installed to protect this operator

Proper grounding gives an electrical charge, such as from an electrical static discharge or a near lightning strike, a path from which to dissipate its energy safely into the earth.

Without this path, the intense energy generated by lightning could be directed towards the Elite gate operator. Although nothing can absorb the tremendous power of a direct lightning strike, proper grounding can protect the gate operator in most cases.

⚠ Before digging more than 18" deep, contact local underground utility locating companies. Avoid damaging gas, power, or other underground utility lines.

The earth ground rod must be located within 3 feet from the Elite gate operator. Use the proper type earth ground rod for your local area.

The ground wire **must** be a single, whole piece of wire. **Never** splice two wires for the ground wire. If you should cut the ground wire too short, break it, or destroy its integrity, replace it with a single wire length.

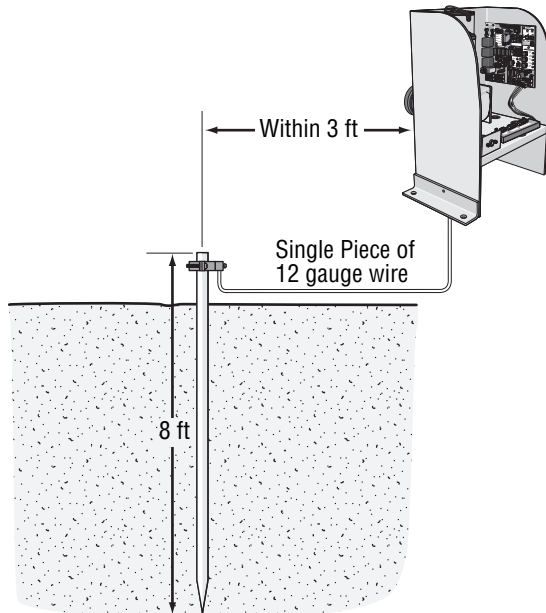

⚠ Elite Access Systems is not responsible for improper installation or failure to comply with all necessary local building codes.

STEP BY STEP INSTALLATION

Step 6: DC Power Supply Connection

Use Elite's optional 18 VAC plug-in transformer (Elite Part # **A POW-1**). Hook up the transformer to 115 VAC. Use two, low voltage, 14 gauge / 300watt direct burial, landscape lighting cables. Hook these wires to the plug-in transformer and to the power input connection on the surge suppressor. Polarity does not matter.

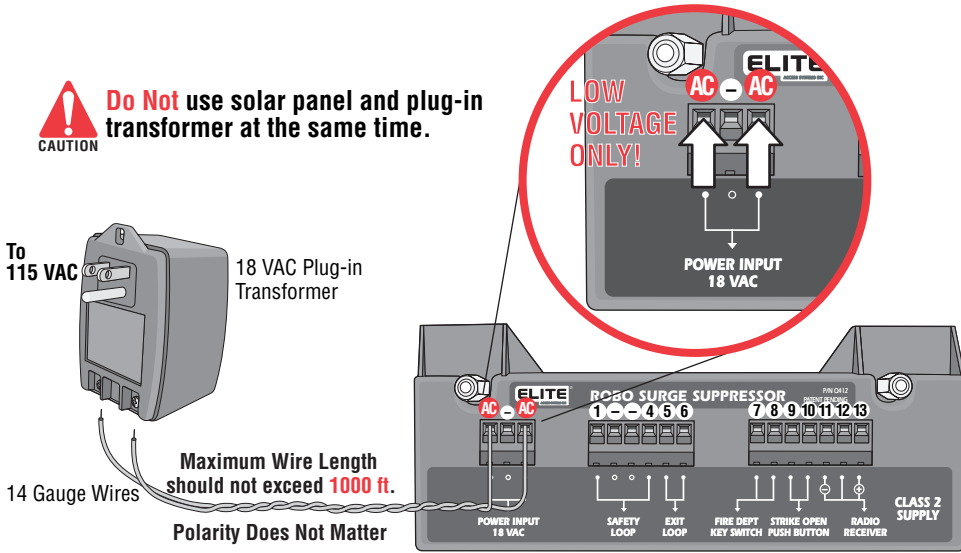

When the plug-in transformer has been connected to the power source, connect the battery cable plug to the motor harness plug. You will hear 3 beeps. After the beeps, check the **“Charge OK” LED.....it must be “ON”**.

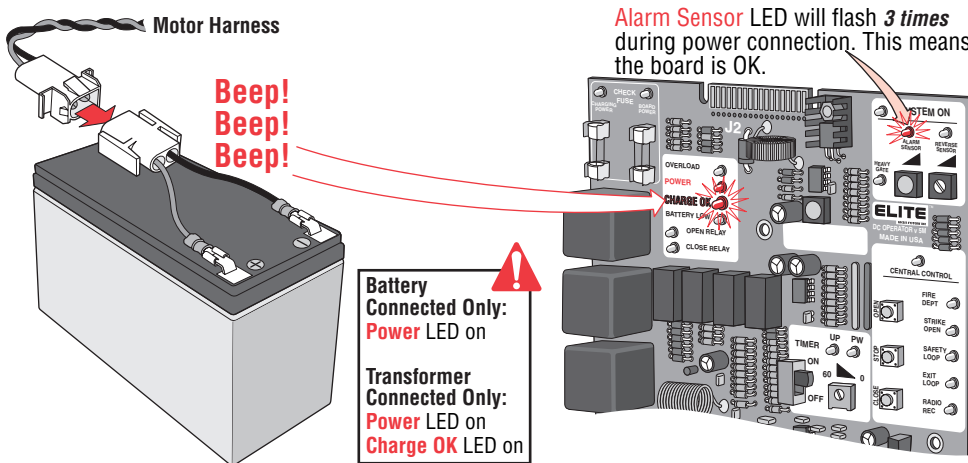

STEP BY STEP INSTALLATION

STEP 7: Optional Solar Panel Connection

If you use Elite's optional solar panel (Elite Part # **Solar 3**). Connect the two wires from the solar panel to the power input connection on the surge suppressor (Polarity does not matter). Sunlight will energize the batteries through the solar panel. This solar panel will charge up to 1000 Mamp/Hr in optimum conditions & 300 Mamp/Hr in light overcast conditions. For further details about Elite's solar panel, consult the "Solar 3" Installation sheet that is included with the solar panel.

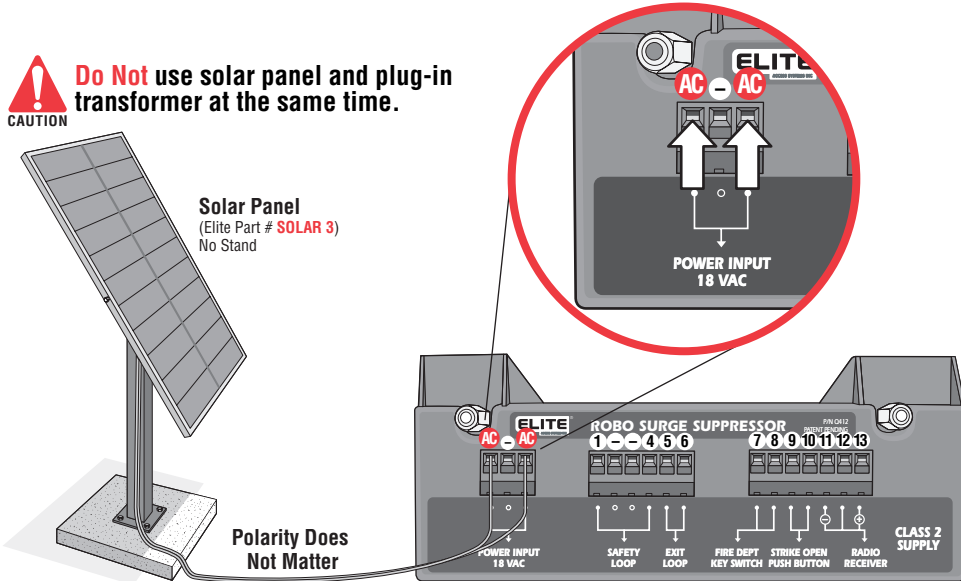

Energizing this operator with solar power only needs the radio receiver to operate the gate. The only recommended external devices other than radio receivers are dry-contact command devices which do not consume any current like key switches. **Using other devices that consume high current such as telephone access, magnetic locks or loop detectors will cause excess drainage of the battery and eventually completely drain the battery .**

CAUTION Elite recommends using a larger battery (12 VDC, 30 Ahr) (Elite Part # **A 12330**) in this operator when using the optional solar panel.

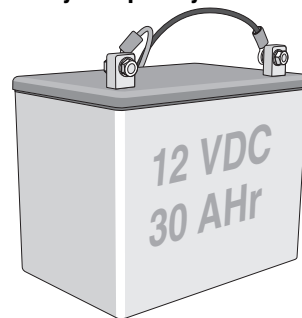

**For More Details,
contact your Local Dealer**

STEP BY STEP INSTALLATION

STEP 8: Surge Suppressor Terminal Connections

The radio receiver **must be 12 VDC only** (Elite Part # **A 1099-12V**). If you want to use safety or exit loops, you **must use 12 VDC loop detectors only** (Elite Part # **A 23**).

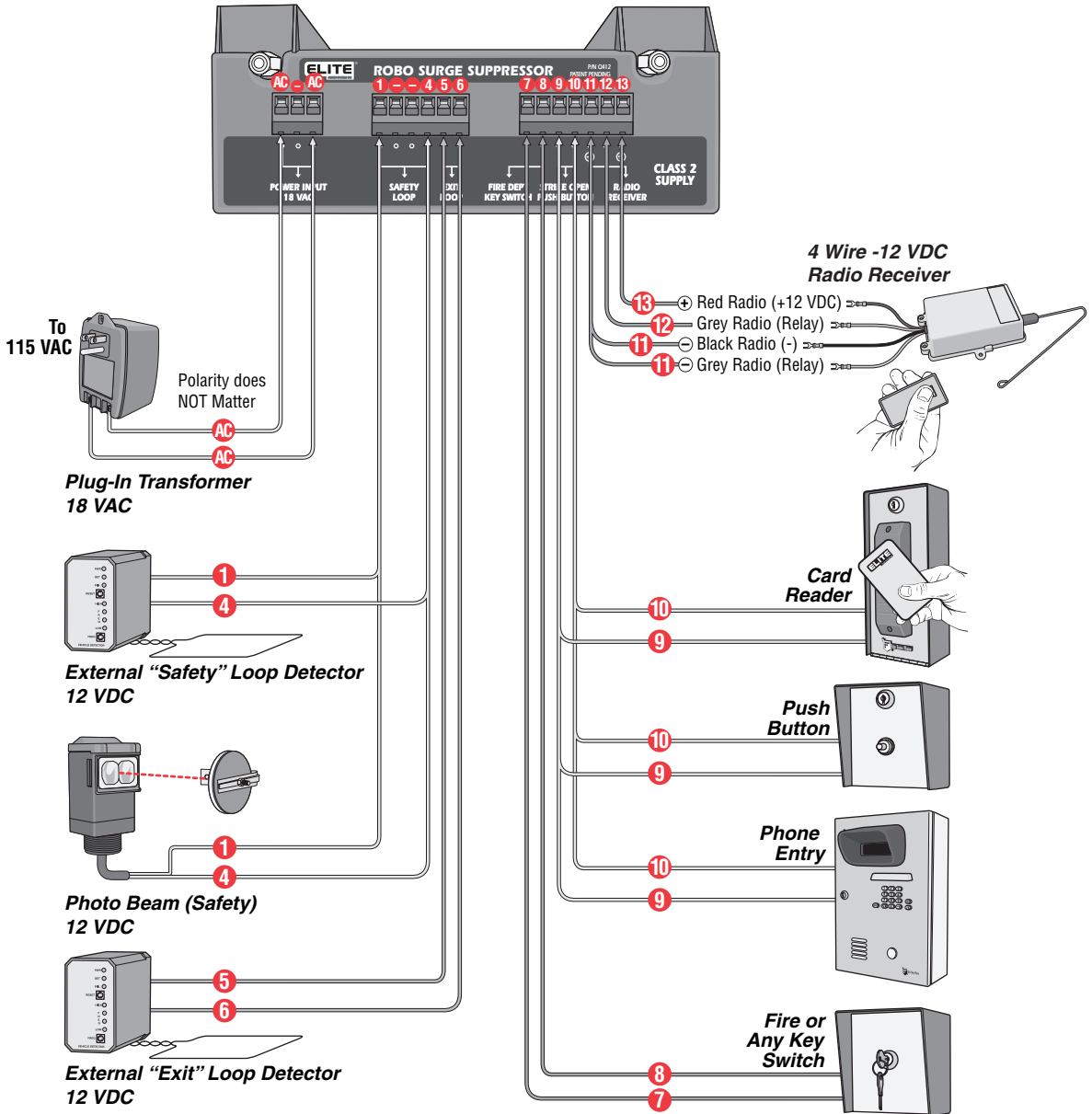

STEP BY STEP INSTALLATION

STEP 9: Adjusting Gate Travel Distance

Adjustment is done by **limit switches** which are located on the Robo Slide chassis. By pressing the plate down and spinning the adjustment nuts, set your limit switches for open and close cycles.

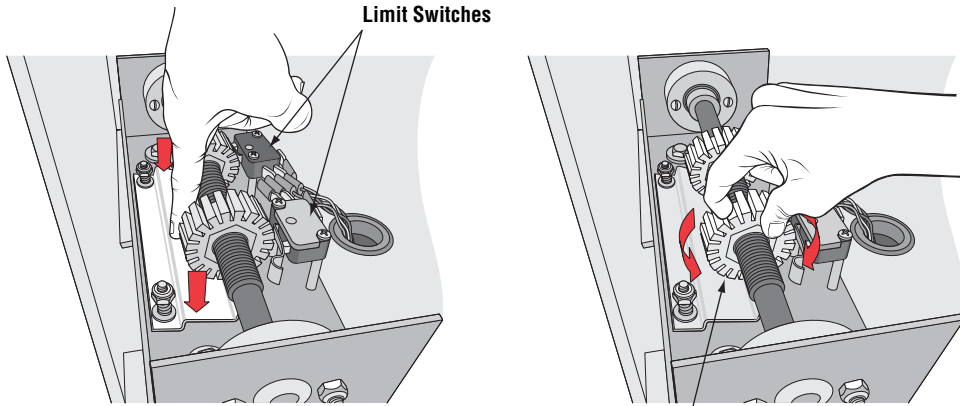

Each notch of the nut indicates an estimated 1 inch of gate travel

STEP 10: Timer

If you want to use the **automatic close** for the gate system, the timer switch should be set to the “**ON**” position. If you want to use the **push open** or **push close** command, the timer should be set to the “**OFF**” position.

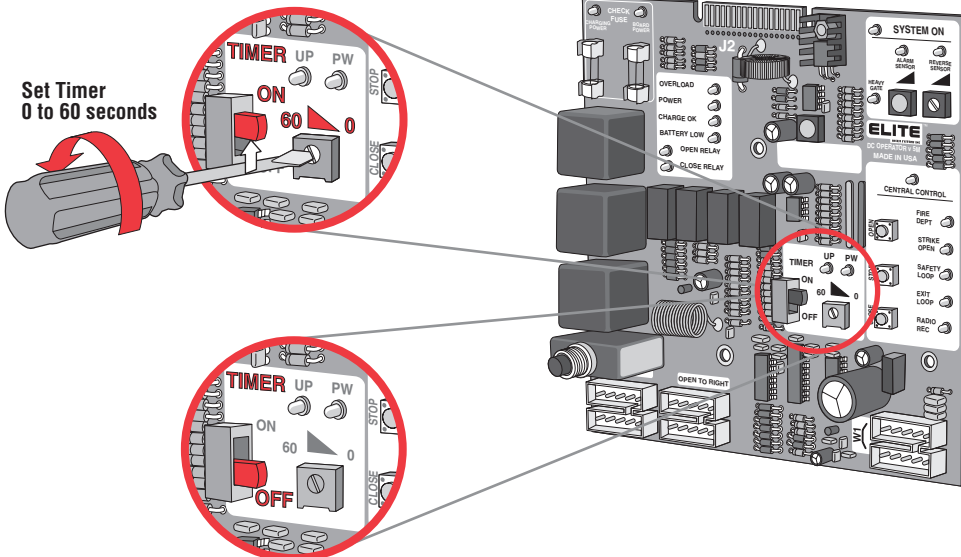

STEP BY STEP INSTALLATION

STEP 11: Two-Way Adjustable Reversing Sensor

Adjust the “**Reverse Sensor**” pot on the upper portion of the control board. **Do Not Touch Alarm Sensor pot.**

The level of reverse sensitivity depends on the weight of the gate and the condition of installation.

Too sensitive = if the gate stops or reverses by itself.

Not sensitive enough = if the gate hits an object and does not stop or reverse.

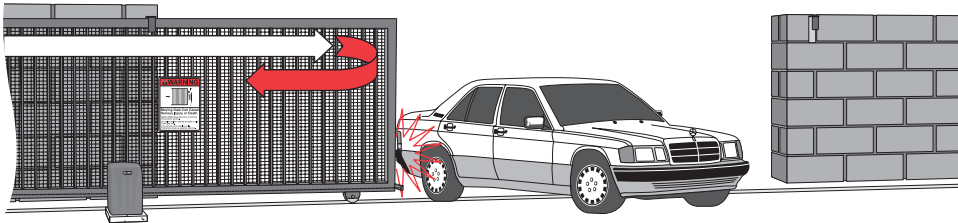

Do Not Touch Alarm Sensor Pot

Minimum Sensitivity

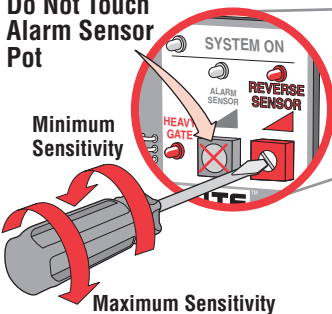

Maximum Sensitivity

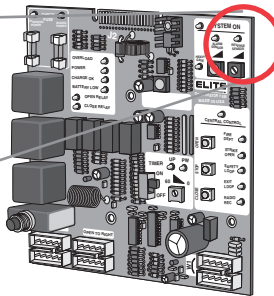

Important Note!

There is a “**Heavy Gate**” LED which will light up when the gate is heavier than normal. This is a diagnostic LED and the operator will still function normally when this indicator is on.

STEP 12: Warning placards need to be permanently mounted on BOTH sides of the gate.

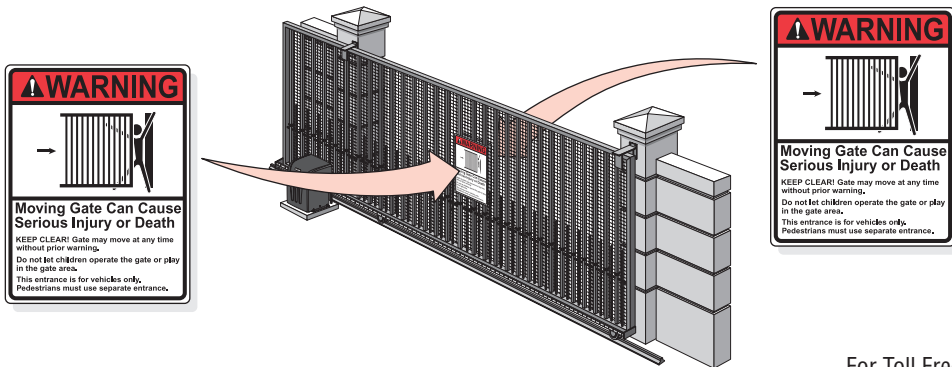

NOW YOUR INSTALLATION IS COMPLETE

For Toll Free
Technical Support:
1-888-ELITE-10
35483

“OPTIONAL” FIRE RELEASE BOX

The “Fire Release Box”, is designed for use on sliding gates. It consists of a plated box, with doors on the front and back. The doors can be locked with your own padlock, or the fire department's padlock. The fire box would be fixed to the gate pickets. It can be opened from either side of the gate. A steel cable with a t-handle runs from the box to the release mechanism at the rear end of the chain. We do not provide the 1/2" EMT to run the cable through. The release mechanism, is placed where the chain bolt would normally be. when you pull on the t-handle, you release the chain from the bolt. To reset, simply reinsert the pin into the housing for normal operation. (Elite Part # **A CP-17**)

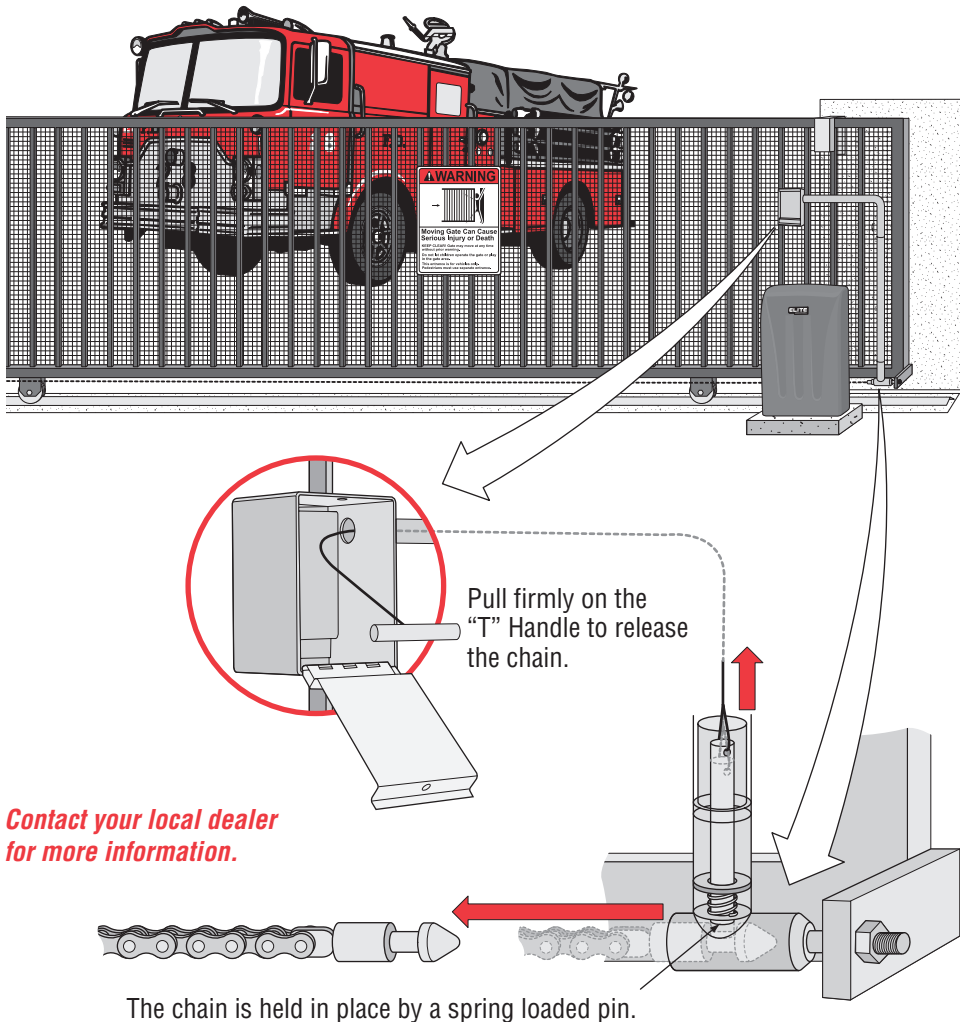

“ O P T I O N A L ” I N P U T B O A R D

The optional board allows extra control of the gate, is available only from Elite Access Systems. Installation is simple; just clip the optional board to the **J2** slot on the top of the control board. Below lists the function of each pin.

- 1 & 2** Open Switch (N.O.)
- 3 & 4** Stop Switch (N.C.) (Cut **W1** Jumper at Bottom of Board)
- 5 & 6** Timer Close Output to Slave
- 7 & 8** Timer Input from Master (Close Command or Close Switch) (N.O.)
- 9 & 10** Alarm Output will be set off with very heavy gates or object preventing gate operation. (Not Burglar Alarm) (9 = +12 VDC, 10 = Alarm)
- 11 & 4** Emergency Open Switch (Direct Command from Battery to Motor)
- 12 & 7** Emergency Close Switch (Direct Command from Battery to Motor)
- 13 & 14** Magnetic Lock - Dry Contact Relay (13 = Com, 14 = N.C.)
- 15 & 16** Center Loop Option (For Swing Gate Operators Only)

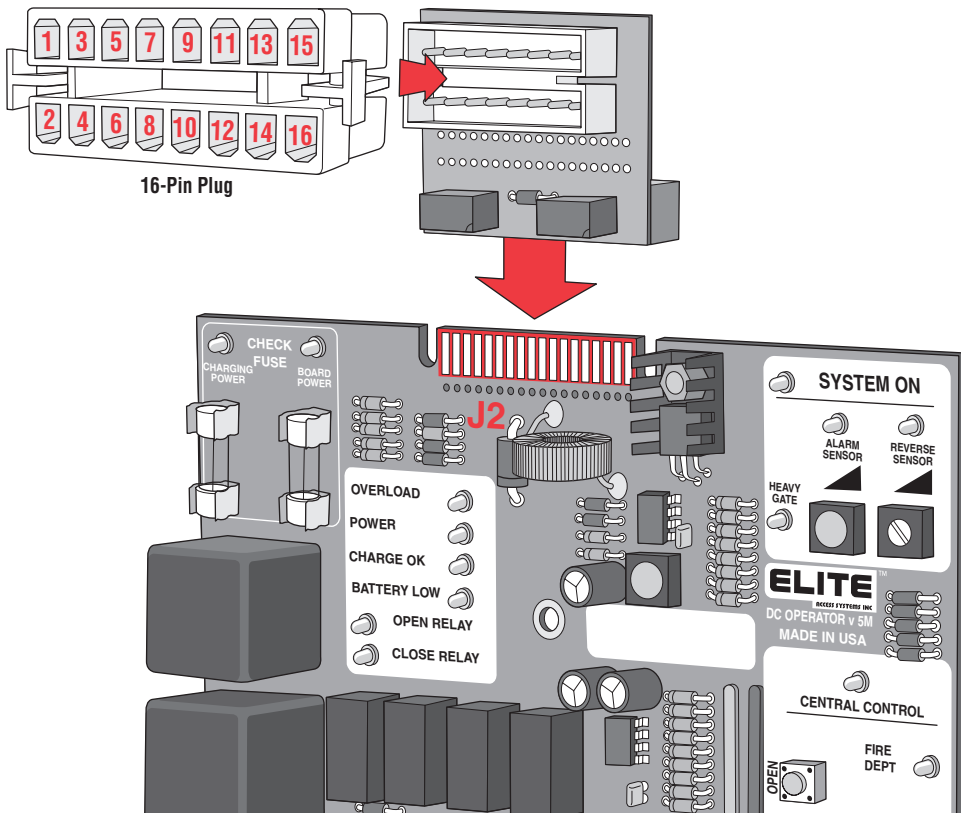
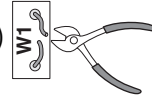

MAGLOCK WIRING CONNECTION

The "Optional" input board **MUST** be used to perform this function. (Elite Part# **Q203**)

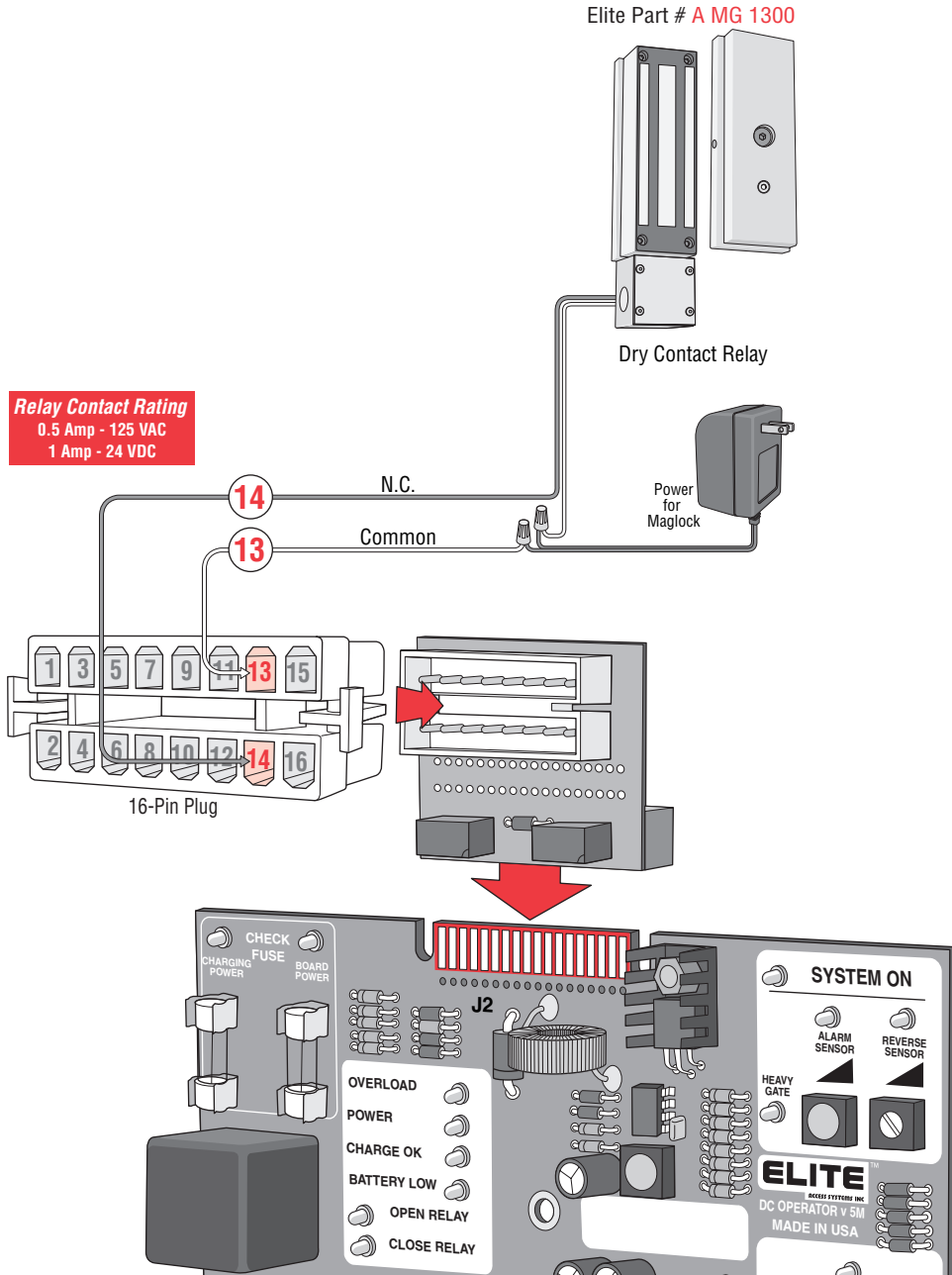

“ OPTIONAL ” 12 VDC PHOTO BEAM WIRING

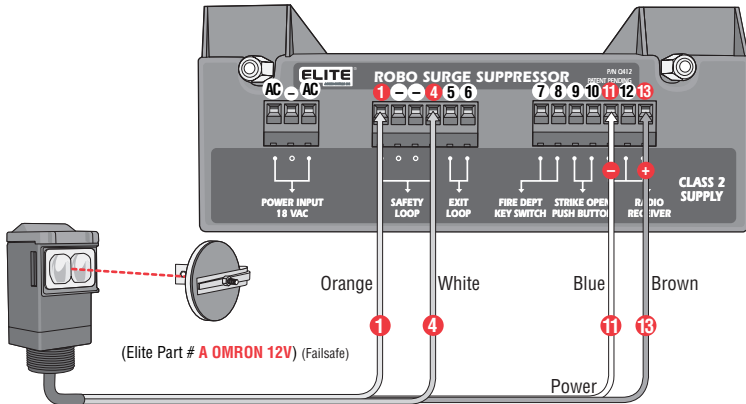
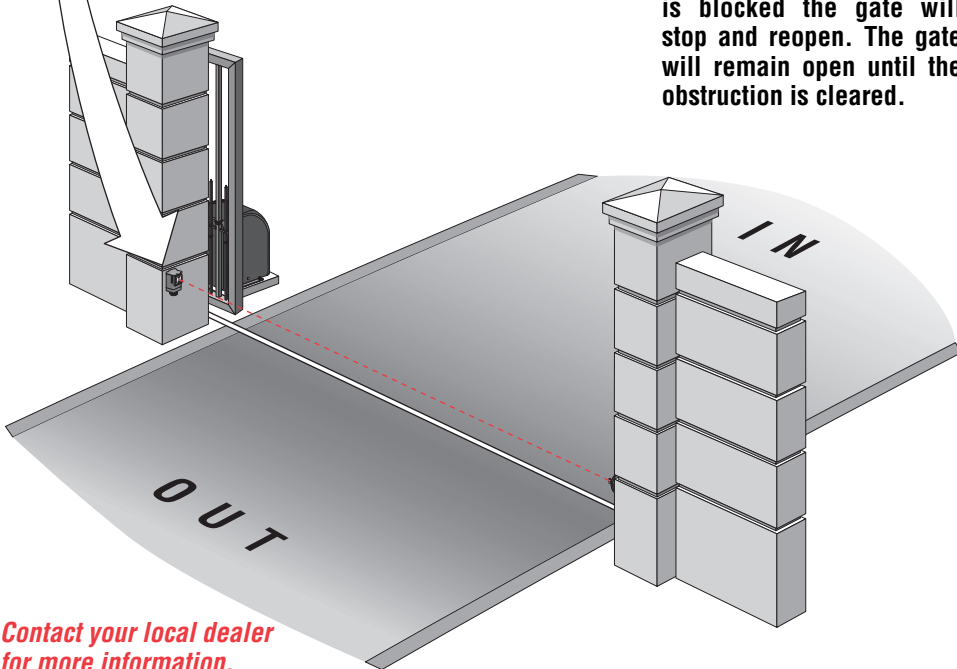

Photo Beam (Safety) 12 VDC

It is best to use 12 VDC Failsafe Photo Beam Sensors for this Safety Option

Failsafe Photo Beam: If a failsafe photo beam is not working or loses power or photo beam is blocked, then the photo beam will stop **all** gate operation.

Important: If photo beam is blocked the gate will stop and reopen. The gate will remain open until the obstruction is cleared.



Contact your local dealer for more information.

3 - PUSH BUTTON WIRING CONNECTION

The "Optional" input board **MUST** be used to perform this function. (Elite Part# **Q203**)

There can be **NO** common wires within this 3-push button station.

Open-N.O. Contact
 Stop-N.C. Contact
 Close-N.O. Contact

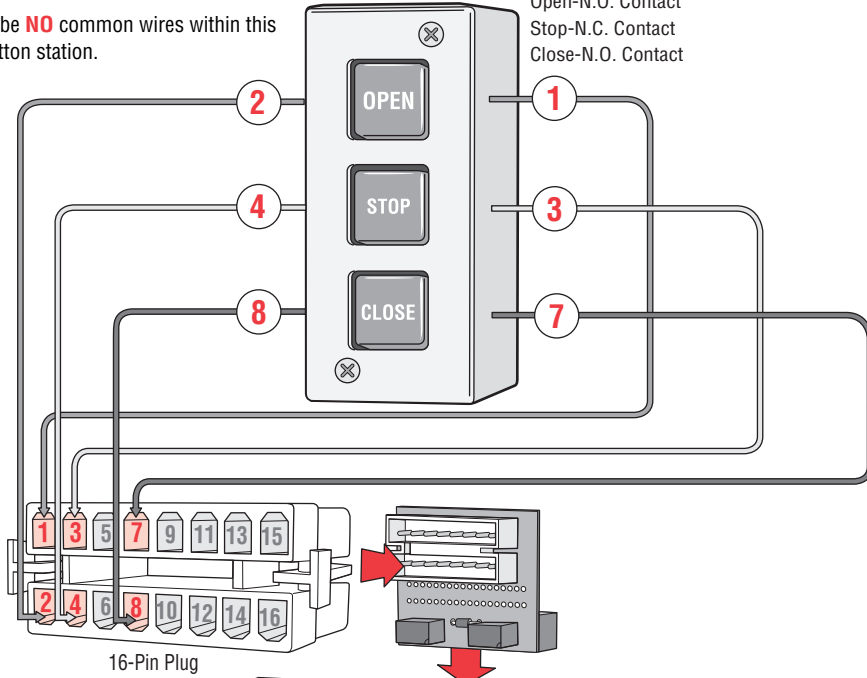

16-Pin Plug

! Cut **W1** jumper at the bottom of Board to use the stop button in the 3-push button station

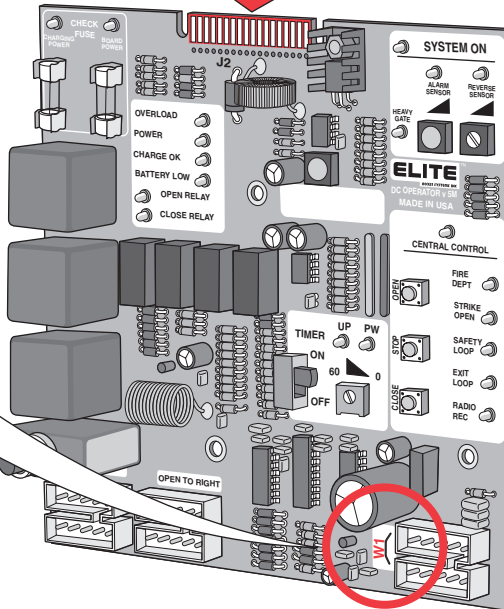
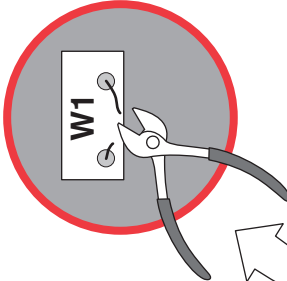

3 - PUSH BUTTON WIRING MASTER / SLAVE

The “Optional” input board **MUST** be used on both operators to perform this function (Elite Part# **Q203**). A 12 VDC Double Pull Double Throw (DPDT) 3 Amp Minimum Relay must be used (Not Included).

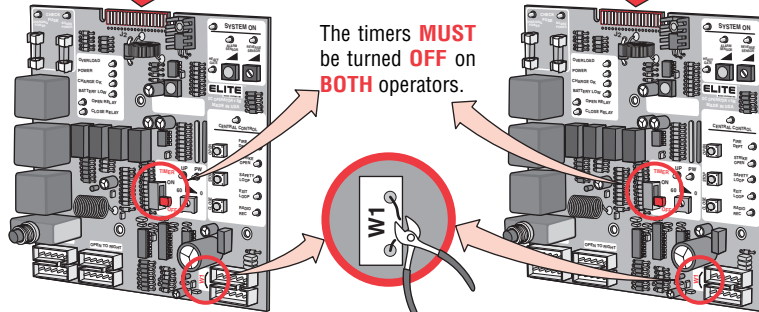
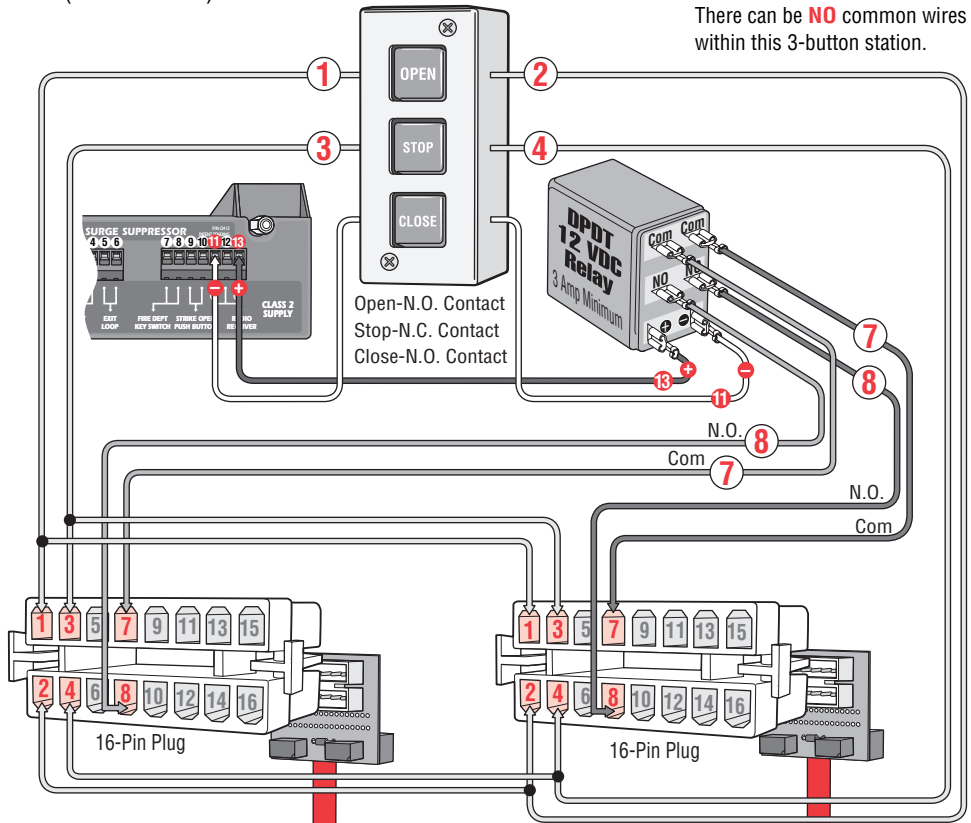

! Cut W1 jumper at the bottom of each board to use the stop button in the 3-push button station

OPTIONAL EDGE SENSOR WIRING

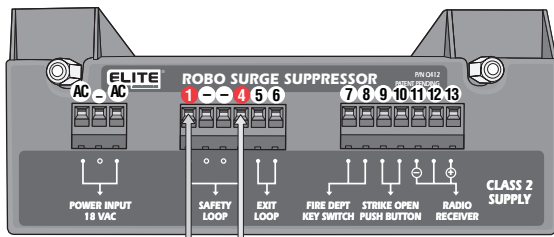

- Never Paint Sensing Edge
- Never Pull On Wires
- Never Cut or Puncture Edge
- Never Operate Unguarded Equipment

Use #10 Screws as necessary to mount Edge Sensor

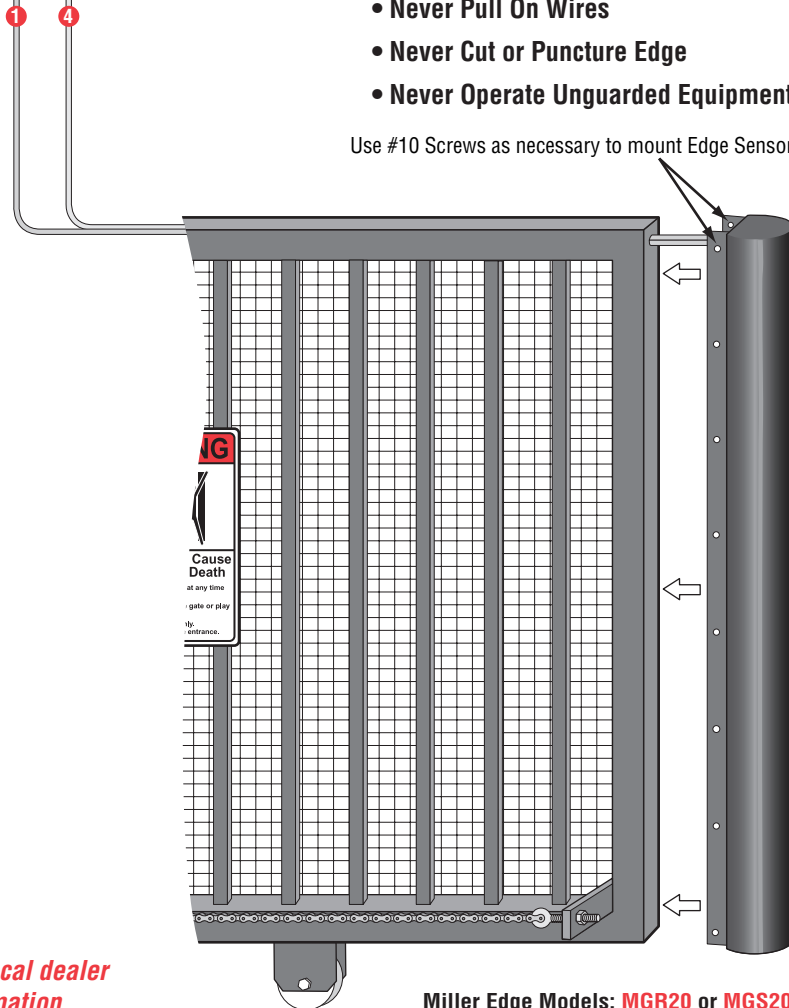

*Contact your local dealer
for more information.*

Miller Edge Models: **MGR20** or **MGS20**

SINGLE OPERATOR LOOP SIZE AND PLACEMENT

It is **VERY** important to have enough separation between loops and gates to prevent false detection.

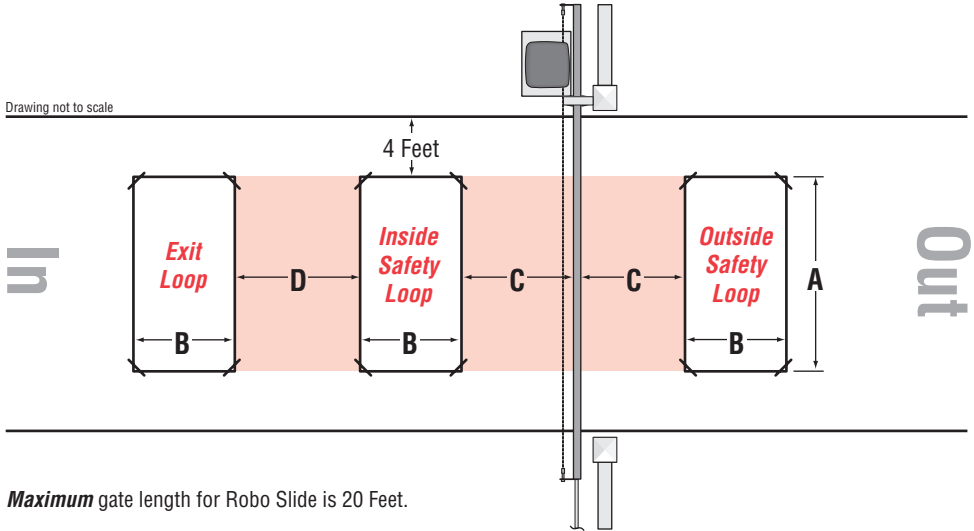

As **A** increases in size to cover a larger gate opening, the gate will cause a larger change of inductance when opening and closing. Therefore dimension **C** must increase as **A** increases.

If A =	6 Feet	9 Feet	12 Feet	15 Feet	18 Feet	21 Feet
Then C =	4 Feet	4.5 Feet	5 Feet	5 Feet	5.5 Feet	6 Feet

Dimension **D** should be equal to or greater than the larger of the “**Inside Safety Loop**” or “**Exit Loop's**” dimension **B**.

If the Inside and outside safety loop are connected to the **same** loop detector they should be series connected. Dimension **A**, **B** and **C** should be the same for each loop. Both loops should have the same number of turns of wire.

This is for a typical single Robo Slide loop installation. Individual circumstances may alter dimensions.

For toll free technical support: **1-888-ELITE-10**

35483

MASTER / SLAVE LOOP SIZE AND PLACEMENT

It is **VERY** important to have enough separation between loops and gates to prevent false detection.

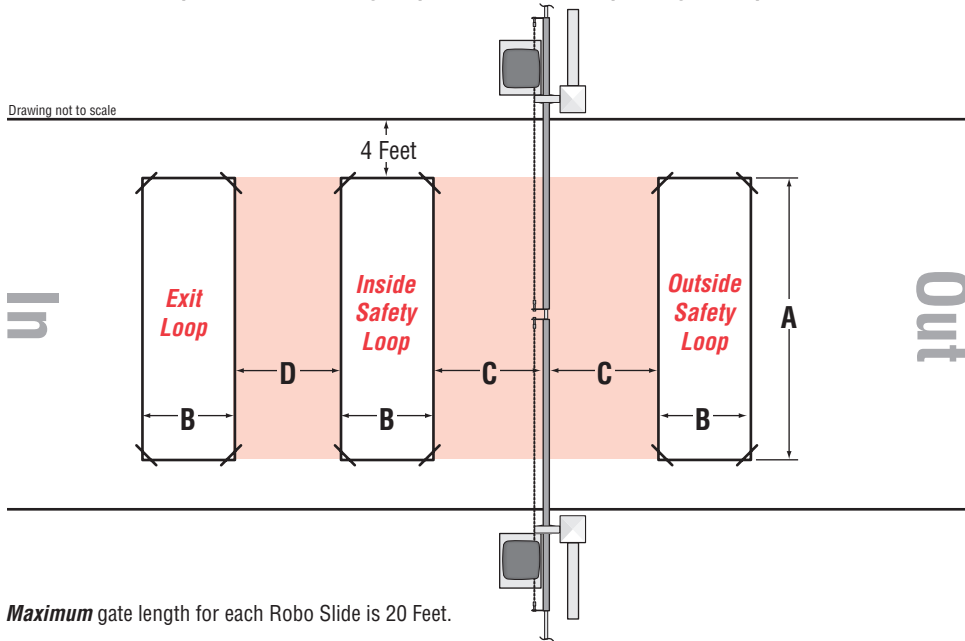

As **A** increases in size to cover a larger gate opening, the gate will cause a larger change of inductance when opening and closing. Therefore dimension **C** must increase as **A** increases.

If A =	6 Feet	9 Feet	12 Feet	15 Feet	18 Feet	28 Feet
Then C =	4 Feet	4.5 Feet	5 Feet	5 Feet	5.5 Feet	6 Feet

Dimension **D** should be equal to or greater than the larger of the “**Inside Safety Loop**” or “**Exit Loop's**” dimension **B**.

If the Inside and outside safety loop are connected to the **same** loop detector they should be series connected. Dimension **A**, **B** and **C** should be the same for each loop. Both loops should have the same number of turns of wire.

This is for a typical master/slave loop installation. Individual circumstances may alter dimensions.

For toll free technical support: **1-888-ELITE-10**

35483

LOOP INSTALLATION AND NUMBER OF WIRE TURNS

Loop Installation “Saw Cut” Type

- 1 Mark the loop layout on the pavement. Remove sharp inside corners that can damage the loop wire insulation.
- 2 Set the saw to cut to a depth (typically 2" to 2.5") that insures a minimum of 1" from the top of the wire to pavement surface. The saw cut width should be larger than the wire diameter to avoid damage to the wire insulation when placed in the saw slot. Cut the loop and feeder slots. Remove all debris from the slot with compressed air. Check that the bottom of the slot is even.
- 3 It is highly recommended that a continuous length of wire be used to form the loop and feeder to the detector. It is also highly recommend using 12-18 AWG cross-link polyethylene (XLPE) insulation for the loop wire. Use heavier wire gauge for a more durable loop area. Use a wood stick or roller to insert the wire to the bottom of the saw cut (Do not use sharp objects). Wrap the wire in the loop saw cut until the desired number of turns is reached. Each turn of wire must lay flat on top of the previous turn.
- 4 The wire must be twisted together a minimum of 6 twists per foot from the end of the saw cut to the detector.
- 5 the wire must be held firmly in the slot with 1" pieces of backer rod every 1 to 2 feet. This prevents the wire from floating when the loop sealant is applied.
- 6 Apply the sealant. The sealant selected should have good adhering properties with similar expansion and contraction characteristics to that of the pavement material.

Number of Wire Turns Needed for Loop

⚠ Important

Loop Perimeter	Number of Wire Turns
10 feet to 13 feet	4
14 feet to 26 feet	3
27 feet to 80 feet	2
80 feet and up	1

⚠ The wire **must** be twisted together 6 twists per foot from the end of the saw cut to the loop detector.

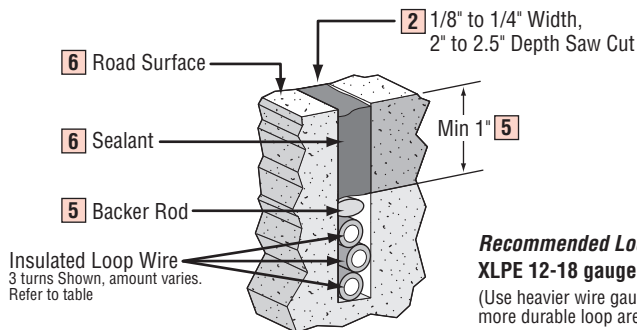
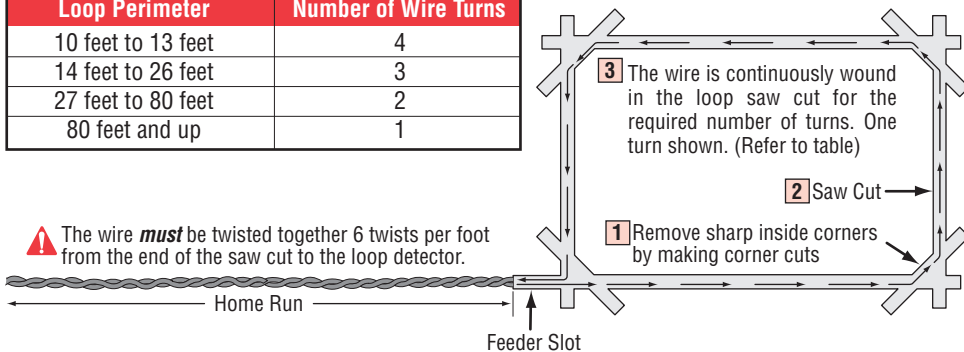

Recommended Loop Wire
XLPE 12-18 gauge
 (Use heavier wire gauge for a more durable loop area)

WIRING LOOP DETECTOR TO OPERATOR

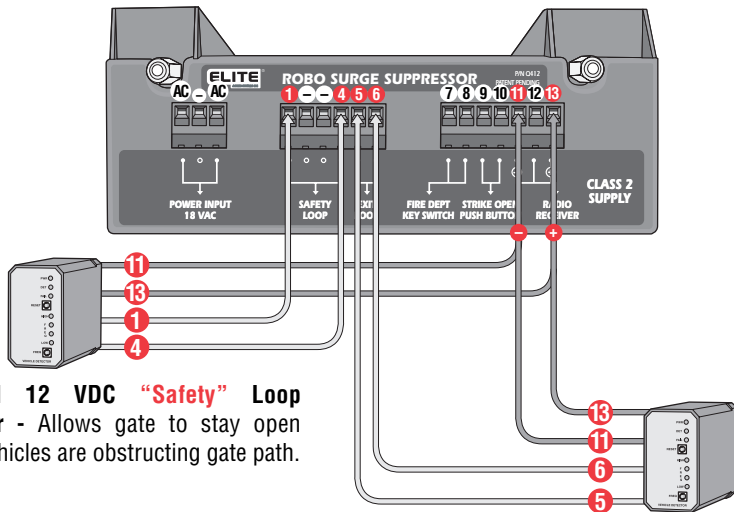

External 12 VDC “Safety” Loop Detector - Allows gate to stay open when vehicles are obstructing gate path.

External 12 VDC “Exit” Loop Detector - Allows gate to automatically open for exiting vehicles.

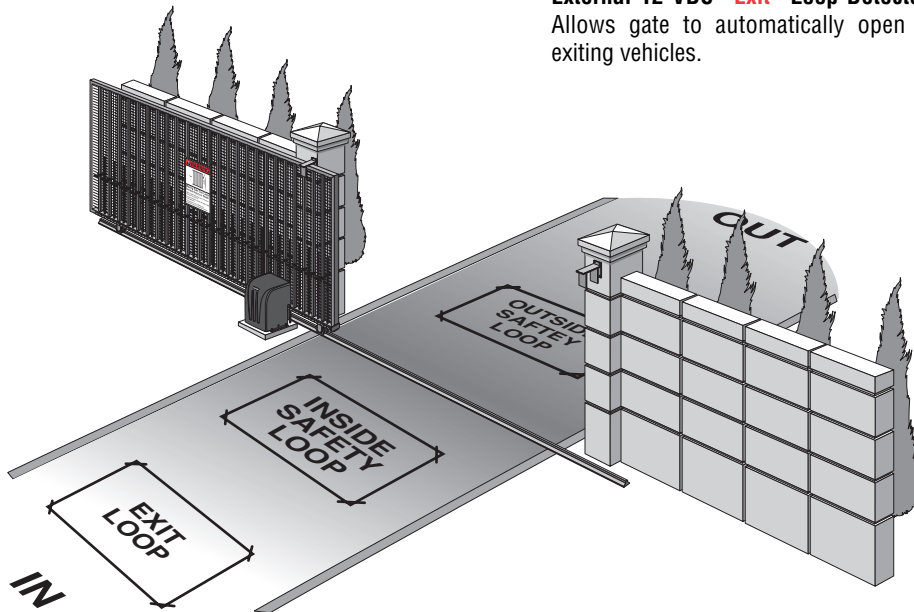

*If the “Inside” and “outside” safety loops are connected to the **same** loop detector:*

- They should be series connected to the detector
- Have the same dimensions. (Page 26 or 27)
- Have the same number of wire turns. (Page 28)

MASTER AND SLAVE WITH TIMER

To use the master/slave option with Robo Slide, you must purchase the **Optional Input Board** (Elite Part # **Q203**) and connect it to the **J2** slot of each operator. (Refer to page 20)

Caution: 18 VAC plug-in transformer, per gate operator required

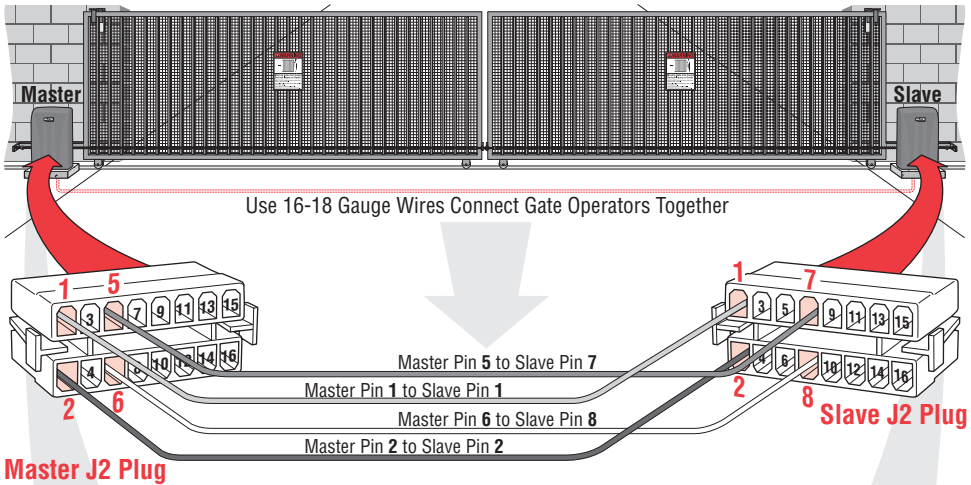

1. Make master/slave J2 plug connections as shown above
2. Turn timers on **BOTH** control boards to the “**ON**” position
3. Use **MASTER** timer **ONLY** for the auto close time adjustment (0 to 60 sec)
4. Turn the **SLAVE** timer adjustment all the way Counterclockwise

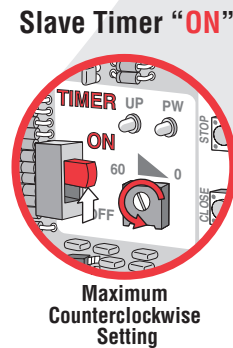
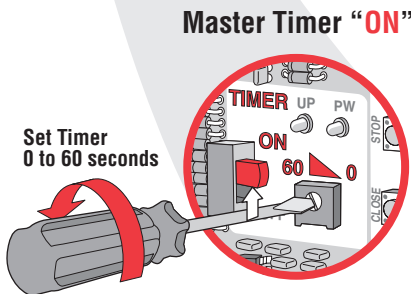

MASTER AND SLAVE WITHOUT TIMER

To use the master/slave option with Robo Slide, you must purchase the **Optional Input Board** (Elite Part # **Q203**) and connect it to the **J2** slot of each operator. (Refer to page 20)

Caution: 18 VAC plug-in transformer, per gate operator required

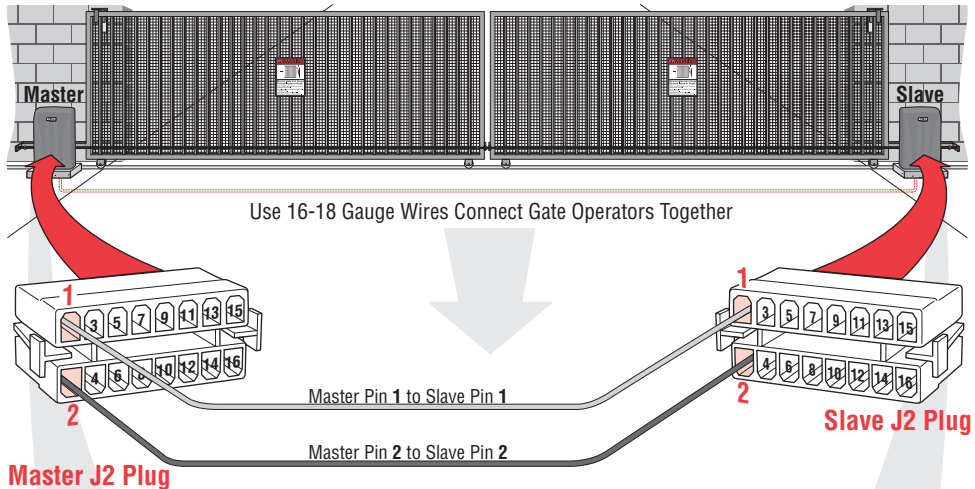

1. Make master/slave J2 plug connections as shown above
2. Turn timers on **BOTH** control boards to the “**OFF**” position

Master Timer “OFF”

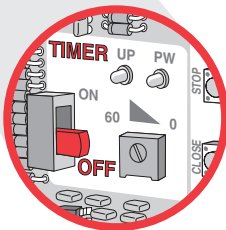

Slave Timer “OFF”

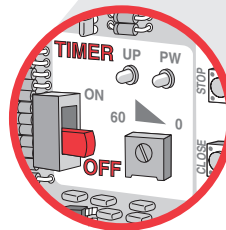

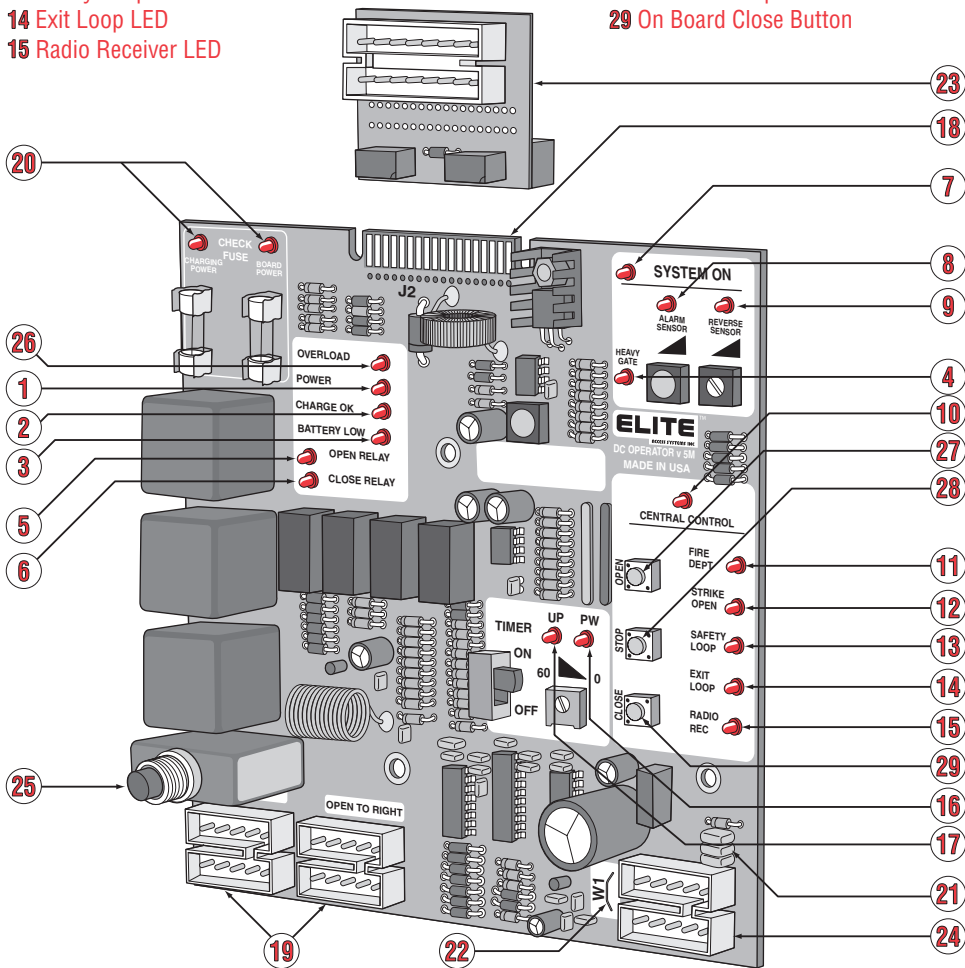

CONTROL BOARD FUNCTIONS

- | | |
|---|---|
| <ul style="list-style-type: none"> 1 Power On LED 2 Charge On LED 3 Low Battery Indicator LED 4 Heavy Gate Indicator LED 5 Open Relay LED 6 Close Relay LED 7 System on, Reversing Sensor and Alarm Sensor 8 Alarm Sensor LED 9 Reversing Sensor LED (Rebounder) 10 Central Control LED 11 Fire Department or Key Switch LED 12 Strike Open LED 13 Safety Loop or Photocell LED 14 Exit Loop LED 15 Radio Receiver LED | <ul style="list-style-type: none"> 16 Timer Power LED 17 Timer-Up Indicator 18 J2 Alternate Optional Output 19 Movement Direction Sockets 20 Replace Fuse Indicator 21 Spike Suppressor 22 Jumper for Stop Button 23 Optional Input Board 24 Surge Suppressor Connector 25 Breaker Reset 26 Overload LED 27 On Board Open Button 28 On Board Stop Button 29 On Board Close Button |
|---|---|





LED DESCRIPTION

<i>LED Description</i>	 LED On	 LED Off
<p>① Power at all times when there is one or more power sources ie: Battery, 18 VAC or solar</p>	<p>Power source OK and board power fuse OK</p>	<p>1. No power source at all <i>If dimmed down</i> 1. Bad board power fuse</p>
<p>② Charger OK on when there is any charging power ie: 18 VAC - solar</p>	<p>Transformer or solar OK and charging power fuse OK</p>	<p>1. No Transformer or Solar <i>If dimmed down</i> 1. Bad Charging power fuse</p>
<p>③ Battery Low normally off - it will indicate low battery</p>	<p><i>Flashing LED - Battery is less than required limit needs to be recharged</i> 1. Excess usage 2. Bad charging system 3. Under rate solar panel 4. Bad battery 5. Bad battery connection</p>	<p>Battery OK Battery voltage is over minimum required limit</p>
<p>④ Heavy Gate will work only when the gate is in motion</p>	<p>1. Gate is too heavy 2. Bad wheels 3. Bad rollers 4. Chain is too tight 5. Steep slope on open or close cycle 6. Low battery</p>	<p>Gate weight and condition are OK</p>
<p>⑤ Open Relay</p>	<p>Open relay is energized</p>	<p>Open relay is not energized</p>
<p>⑥ Close Relay</p>	<p>Close relay is energized</p>	<p>Close relay is not energized</p>
<p>⑦ System On will work only when the gate is in motion</p>	<p>Detecting motor current</p>	<p>1. Motor stop 2. No motor current detected</p>
<p>⑧ Alarm Sensor when LED goes on you will hear a “beep” sound for about 20 seconds</p> <hr/> <p>LED will flash 3 times for “board OK” during power connection.</p>	<p>1. Hearing beep sound means overload 2. Gate is too heavy 3. Broken wheel 4. Gate off track 5. Unwanted object has physically stopped gate</p>	<p>System is OK</p>

Note: Circled red numbers indicates location on control board, identified on page 32.

LED DESCRIPTION - CONTINUED

<i>LED Description</i>	 LED On	 LED Off
9 Reversing Sensor	Sensor is detecting obstruction	No obstruction is detected
10 Central Control	Acknowledgement of receiving open command from one of the surge suppressor terminals <ul style="list-style-type: none"> • Fire Department 7 & 8 • Strike Open 9 & 10 • Safety Loop 1 & 4 • Exit Loop 5 & 6 • Radio Receiver 11 & 12 	Not receiving any command
11 Fire Dept	Receiving signal at the surge suppressor terminal block 7 & 8	Not receiving signal at the surge suppressor terminal block 7 & 8
12 Strike Open	Receiving signal at the surge suppressor terminal block 9 & 10	Not receiving signal at the surge suppressor terminal block 9 & 10
13 Safety Loop	Receiving signal at the surge suppressor terminal block 1 & 4	Not receiving signal at the surge suppressor terminal block 1 & 4
14 Exit Loop	Receiving signal at the surge suppressor terminal block 5 & 6	Not receiving signal at the surge suppressor terminal block 5 & 6
15 Radio Rec	Receiving signal at the surge suppressor terminal block 11 & 12	Not receiving signal at the surge suppressor terminal block 11 & 12
16 Timer PW	Timer power is on	Timer is not on
17 Timer UP	Output signal to close relay	Not receiving signal to close relay

Note: Circled red numbers indicates location on control board, identified on page 32.

TROUBLESHOOTING

How to Reset the Breaker

If all electronic sensors fail or are not adjusted properly due to heavy gates, off-track gate, or obstructed gate path, the breaker will kick-out. Reset the breaker by pressing the reset button located on the bottom left corner of the control board.



Always disconnect the battery before resetting the breaker or injury could occur as the gate starts.

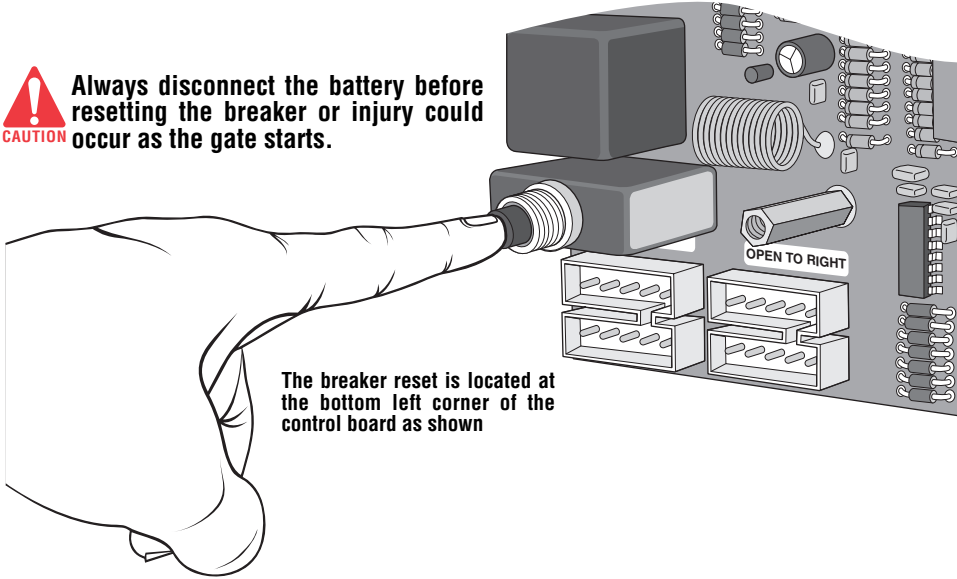

How to Check the Fuses

If the gate is not moving in any direction be sure to check all of the LED displays on the control board. If the board power or charging power LEDs are **“ON”**, change the corresponding fuse on the top left corner of the board.



Replace fuse with 1.5A - 250V fuse

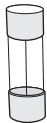

Robo Fuse
(Elite Part # **Q162**)

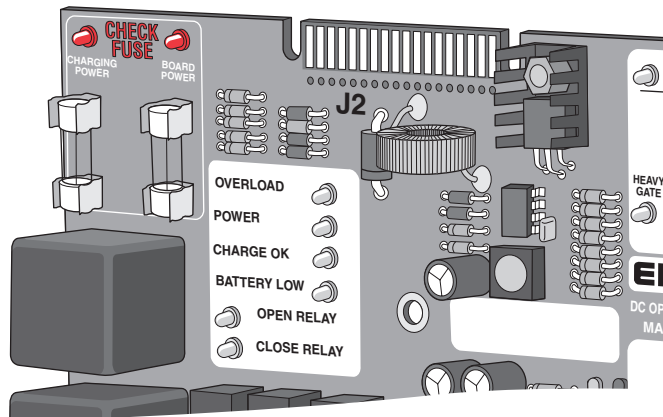

TROUBLESHOOTING

The Gate Will Not Close!

For Toll Free Technical Support: 1-888-ELITE-10

35483

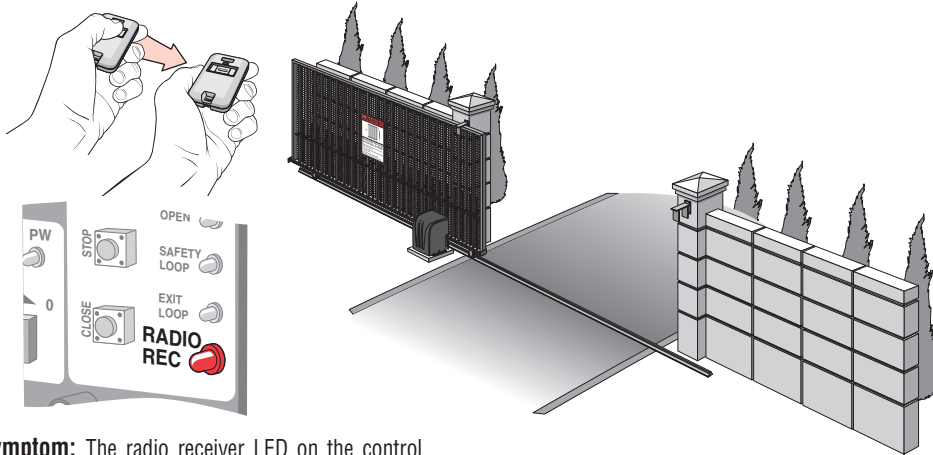

Symptom: The radio receiver LED on the control board remains “ON” when using the remote control.

Possible Solutions: Stuck remote control button. The radio receiver has malfunctioned in the “ON” position.

The Gate Will Not Open!

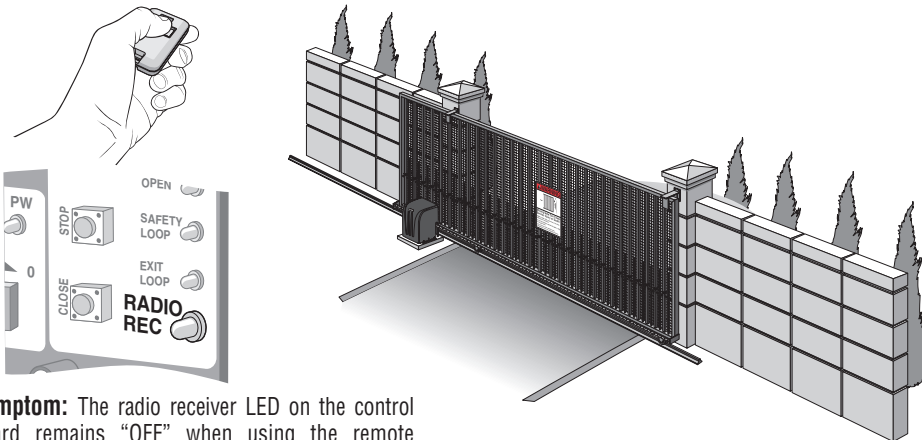

Symptom: The radio receiver LED on the control board remains “OFF” when using the remote control.

Possible Solutions: Dead battery in the remote control. Remote control code switches are different from radio receiver code switches. The radio receiver has malfunctioned in the “OFF” position.

For further information, contact your local dealer.

TROUBLESHOOTING

If you hear a  **“BEEP”** sound.....



The gate is TOO Heavy.

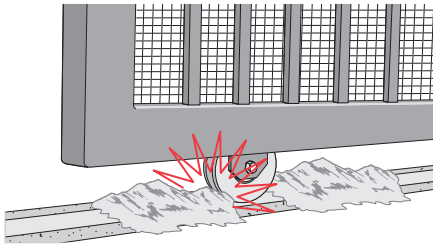
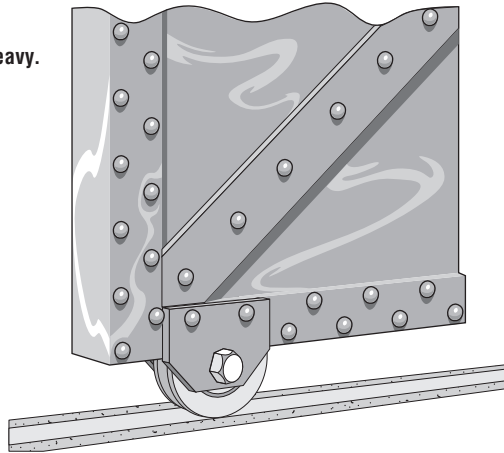

Debris is on the gate's track such as mud, rocks, dirt, etc.

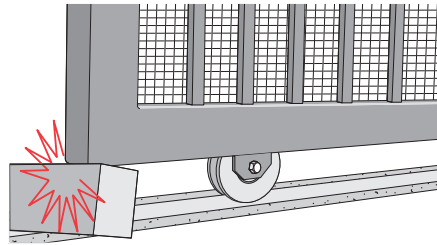

The gate is hitting a wall or vehicle.

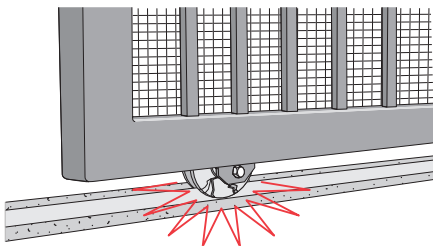

The gate has one or more broken wheels.

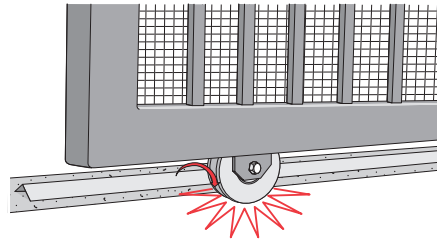

The gate is off the track.

After fixing the problem, the Robo Slide will automatically reset itself.

ROBO SLIDE PARTS



Q241

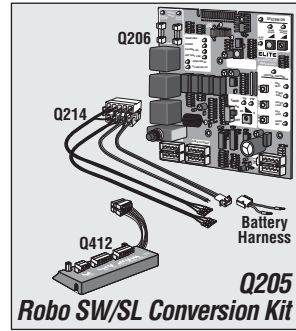

Q205
Robo SW/SL Conversion Kit



Q203

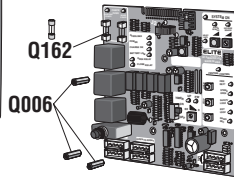

Q206

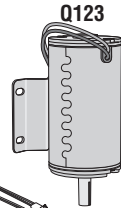

Q123

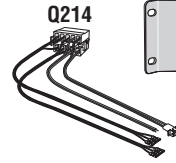

Q214

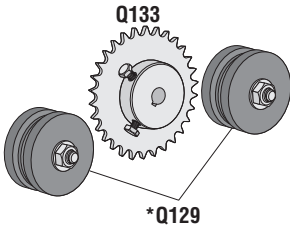

*Q129

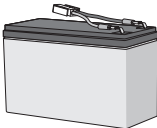

A BT 12

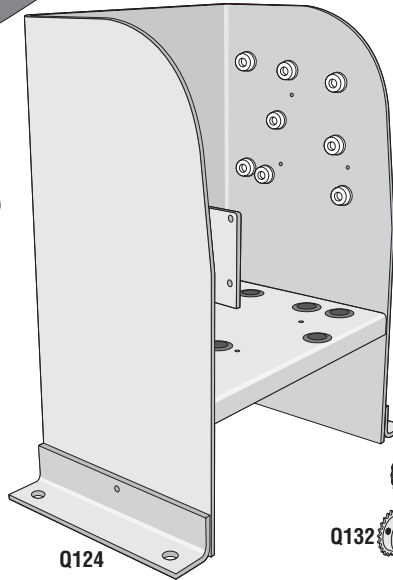

Q124



Q412



Q180

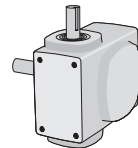

Q212



Q131

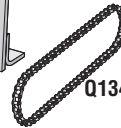

Q134

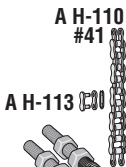

A H-110
#41

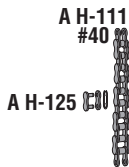

A H-111
#40



A H-113



A H-125

*Q003

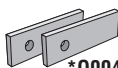

*Q004

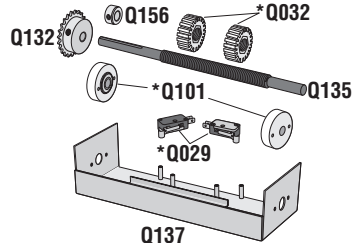

Q135

Q132

Q156

*Q032

*Q101

*Q029

Q137

Note: *Sold Individually, 2 Shown.
For part list, refer to next page.

PARTS LIST

Robo SW / SL Conversion Kit

Q205	— Q211 - Limit/Motor Harness
	— Q412 - Surge Suppressor Terminal
	— Q206 - Control Board
	— Battery Harness

A BT 12 - 12 VDC, 7 amp. Battery with Harness
A H-110 - Gate Chain #41 (10 ft) (20 ft included)
A H-111 - Gate Chain #40 (10 ft) Optional
A H-113 - Master Link #41
A H-125 - Master Link #40
Q003 - Chain Bolt
Q004 - Chain Bracket
Q006 - PC Board Nuts (1 Set)
Q029 - Limit Switch
Q032 - Limit Switch Adjustment Nut
Q101 - Limit Switch Bearing Holder
Q123 - Motor - DC - 12V

Q124 - Chassis - Robo Slide
Q129 - Idler Sprocket with Bolt/Nut
Q131 - Limit Switch Drive Sprocket
Q132 - Limit Switch Sprocket
Q133 - Drive Sprocket
Q135 - Limit Switch Bolt (Shaft)
Q137 - Limit Switch Box
Q156 - 1/2 Inch Collar
Q162 - Fuse
Q180 - 1 inch Diameter Coupling
Q203 - Option Board with Harness
Q206 - Control Board
Q212 - Gear Reducer 40 - 30:1
Q214 - Limit/Motor Harness
Q241 - Cover, Polyethylene Robo Slide
Q412 - Surge Suppressor Terminal

Multiple Parts "Q" Number

MAINTENANCE

Make sure the reversing sensor is functioning properly. (Page 18)

Make sure the gate track is clear of dirt, rocks or other substances.

Make sure the wheels are operating smoothly on the track.

Oil the chain regularly with a chain lubrication oil available at most motorcycle stores.

Important: Any service must be performed by an authorized service technician.

Please call your local service company for maintenance and repairs.



PLEASE DO NOT TOUCH ME!...UNLESS YOU ARE AN AUTHORIZED SERVICE TECHNICIAN!

ELITE ROBO SLIDE ACCESSORIES

12 VDC Radio Receiver

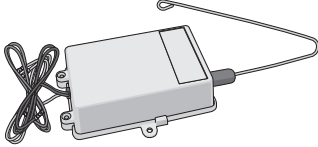

(Elite Part # **A 1099 12V**)

Transmitter

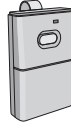

(Elite Part # **A 3089**)

12 VDC Photo Beam

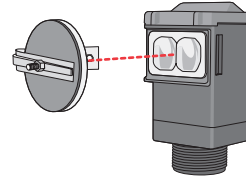

(Elite Part # **A OMRON 12V**)

18 VAC Plug-in Transformer



(Elite Part # **A POW 1**)

Magnetic Locks (Outdoor)

(Elite Part # **A MG 1300**)

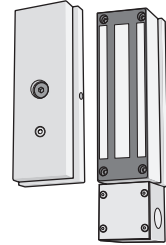

Solar Panel

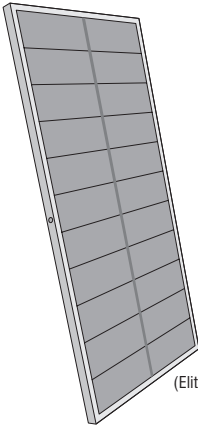

(Elite Part # **SOLAR 3**)



Power Wheels Series

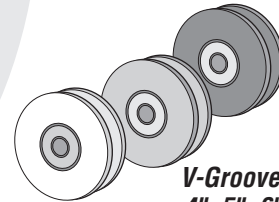

**V-Groove
4", 5", 6"**

12 VDC 30 Ahr Battery

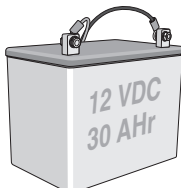

(Elite Part # **A 12330**)

12 VDC External Loop Detectors

(Elite Part # **A 23**)

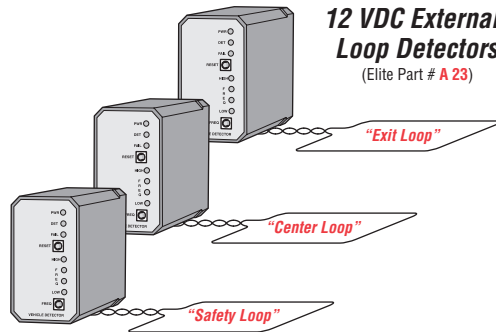

OWNERS CHECKLIST OF INSTALLATION

1. Owner and Installer must read all warnings and safety precautions and be aware of their roles and responsibilities. (Pages 2-9)
2. Make sure concrete mounting pad is big enough and deep enough for operator. (Page 11)
3. Operator must be **securely** fastened to concrete pad. (Page 11)
4. Operator chain must be **4" Minimum** from gate. (Page 11)
Chain must not be too tight or too loose.
5. Gate operator must be grounded to an earth ground rod within 3 feet. (Page 13)
6. Verify that both the battery and plug-in transformer are connected properly. (Page 14)
7. Verify that the gate opens and closes as needed. (Page 17)
8. When gate hits object during operation, it **must** stop or reverse. (Page 18)
9. Make sure that any pinch point or potential entrapment are guarded by means of safety devices or like. (Page 7, 22, 25)
10. Warning placards need to be permanently mounted on **both** sides of gate. (Page 18)
11. Test all additional equipment connected to operator.
12. Make sure **all** wire connections are **securely** fastened.
13. Review typical maintenance on operator. (Page 39)
14. Schedule periodic maintenance on operator by qualified service technician.
15. Inquire about Manufacturers "*operator warranty*". (Warranty Card Included with operator)
16. Inquire about **separate** "*installation warranty*" with installer.

FEATURES AND SPECIFICATIONS

We suggest the following items manufactured by Chamberlain Professional Products for better and safer operations.

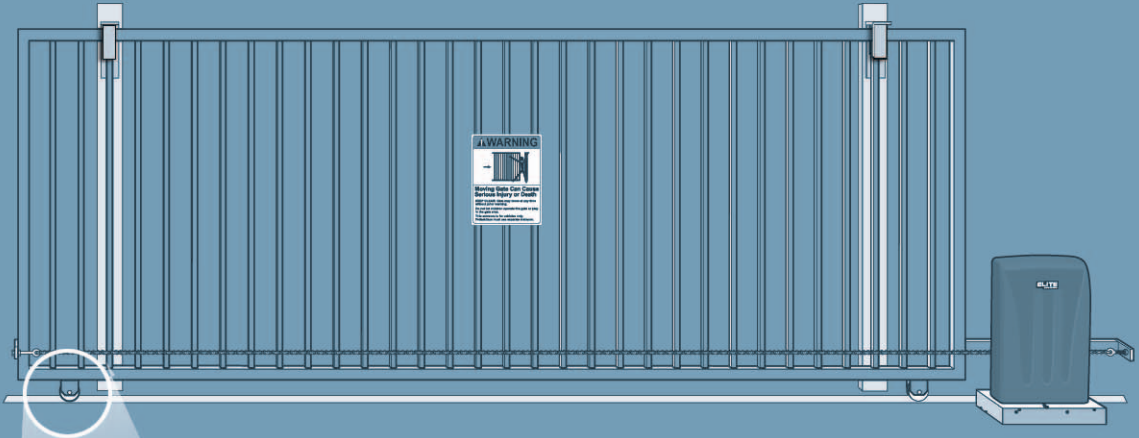

POWER WHEELS

These wheels are the best choice for high traffic sliding applications.

WARNING SIGN

Use a warning sign on gate to prevent injury to children.



ATTENTION

In order to reduce any severe injuries, Chamberlain Professional Products recommends the electric gate be either; covered with a mesh or installed in such a way which to prevent small children or any other persons from being able to stand, hang or climb on the electric gate.