

# CHAMBERLAIN®

chamberlaindiy.com.au  
chamberlaindiy.co.nz

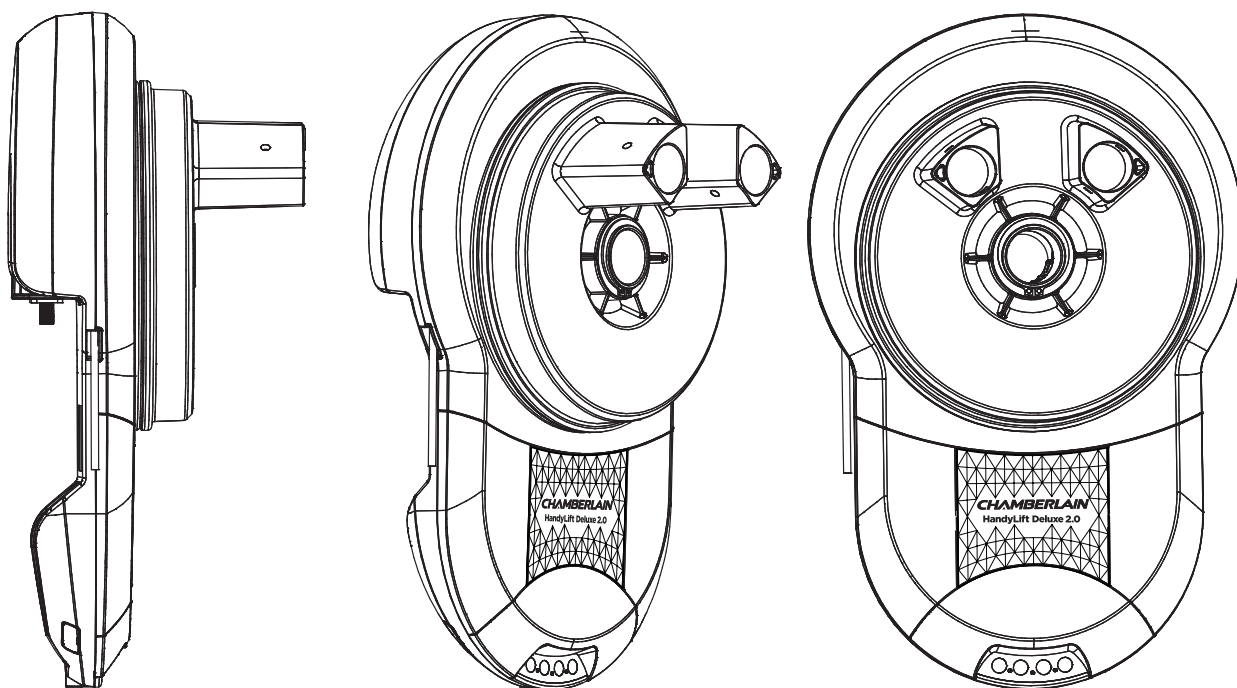

## HandyLift Deluxe 2.0

### CR675EVO

#### Garage Roller Door Opener

#### Installation and Operating Instructions

Owners Copy: Please keep these instructions for future reference



This manual contains IMPORTANT SAFETY information  
DO NOT PROCEED WITH THE INSTALLATION UNTIL READING THE  
INSTRUCTIONS THOROUGHLY



# Warranty Registration

Register your warranty at:

[chamberlaindiy.com.au/warranty](http://chamberlaindiy.com.au/warranty)

or

[chamberlaindiy.co.nz/warranty](http://chamberlaindiy.co.nz/warranty)

***CHAMBERLAIN***®

# START BY READING THESE IMPORTANT SAFETY INSTRUCTIONS

## WARNING

- Failure to comply with the following instructions may result in serious injury or property damage.
- Read and follow all instructions carefully.
- The garage door opener is designed and tested to offer safe service provided it is installed and operated in strict accordance with the instructions in this manual.



These safety alert symbols mean **WARNING**: A possible risk to personal safety or property damage exists.



**Keep the garage door balanced.** Do not let the garage door opener compensate for a binding or sticking garage door. Sticking, binding or unbalanced doors must be repaired before installing this opener.



**Do not wear rings, watches or loose clothing** while installing or servicing a garage door opener. Wear gloves and suitable protective clothing where appropriate.



**Frequently examine the door installation.** In particular examine cable, springs and mountings for signs of wear, damage or imbalance. Do not use if repair or adjustment is needed since springs and hardware are under extreme tension and a fault can cause serious personal injury.



To avoid serious injury from entanglement, **remove all ropes, chains and locks connected to the garage door** before installing the door opener.



**Installation and wiring** must be in compliance with your local building and electrical codes.



**The safety reverse system test is very important.** Your garage door **MUST** reverse on contact with a 40 mm obstacle placed on the floor. Failure to properly adjust the opener may result in serious injury from a closing garage door. **Repeat the test once a month and make any necessary adjustments.**



This appliance should not be used by children or persons with reduced physical, sensory or mental capabilities, or a lack of experience & knowledge, unless they have been given supervision or instruction concerning use of the appliance by a person responsible for their safety.



**Automatic Drive** - Keep away from the area of the door as it may operate unexpectedly.



**This opener should not be installed in a damp or wet space exposed to weather.**



**The opener must not be used on a wicket door (door within a door).**



**The obstruction detection beams must be used for all installations where the closing force as measured on the bottom of the door is over 400 N (40 kgf).** Excessive force will interfere with the proper operation of the safety reverse system or damage the garage door.



**After installation, ensure that the parts of the door do not extend over public footpaths or roads.**



Install the wireless wall control (or any additional wall control) **in a location where the garage door is visible away from moving parts, at a height of at least 1.5 m and out of the reach of children. Do not allow children to operate push buttons or transmitters.** Serious personal injury from a closing garage door may result from misuse of the opener.



**Permanently fasten the warning labels in prominent places,** adjacent to wall controls and manual release mechanisms as a reminder of safe operating procedures.



**Activate opener only when the door is in full view, free of obstructions and the opener is properly adjusted. No one should enter or leave the garage while the door is in motion.**



**Do not allow children to play near the door or with door controls.**



If the power cable is damaged, it must be replaced by the manufacturer, its service agent or similarly qualified persons in order to avoid hazard.



**Disconnect electric power to the garage door opener before making repairs or removing covers.**

**KEEP THESE INSTRUCTIONS**

**NOTE:** If your garage has no service entrance door, we recommend an outside quick release must be installed. This accessory allows manual operation of the garage door from outside in case of power failure.

CONTENTS	PAGE
SAFETY INSTRUCTIONS	1
CARTON INVENTORY	2
TOOLS REQUIRED	2
DOOR REQUIREMENTS	2
CONTROL PANEL	3
PREPARE & TEST THE DOOR	4
OPERATING MANUAL RELEASE	5
PINNING THE DOOR	5
INSTALLATION PROCEDURE	7
ADJUSTMENT & TESTING	8
INSTALL OBSTRUCTION DETECTION BEAMS	10

AUDIBLE BEEP	11
PARTIAL OPENING	11
WIRELESS PROGRAMMING	12
STANDBY MODE (OPTIONAL)	12
OPERATING YOUR OPENER	13
MAINTAINING YOUR OPENER	13
CARE OF YOUR OPENER	13
SPECIFICATIONS	13
WIRING	14
TROUBLESHOOTING	15
ACCESSORIES	16
DIAGNOSTIC CHART	16
WARRANTY	17

## 1 CARTON INVENTORY

1. Instruction manual (this document)
2. Stop collar
3. Clamp bracket, plates, washers (2) and nuts (2)
4. E940C car visor transmitter (1)
5. E950C transmitter (2)
6. Opener
7. Self tapping screws (2)
8. Weight bar screws (2), washers (2) and nuts (2)
9. Warning label and risk of entrapment label
10. Warranty registration card
11. Quick start guide
12. Weight bar

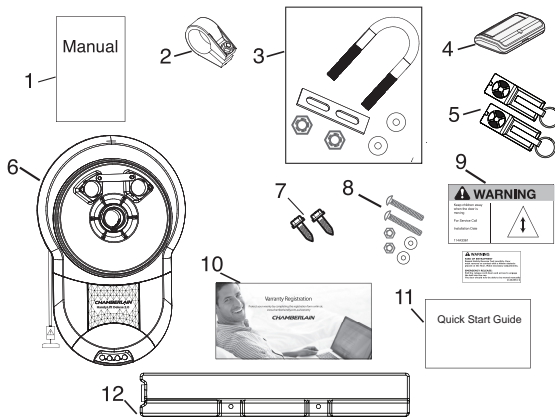

## 2 TOOLS REQUIRED

1. Ladder
2. Adjustable wrench for U-bolts already installed on the door
3. 8 mm socket, 10 mm socket and 13 mm extended socket and socket wrench
4. 300 mm socket extension (for minimum side-room installations)
5. Drill and 5.5 mm drill bit
6. Philips-head screwdriver
7. Marker pen
8. Rope

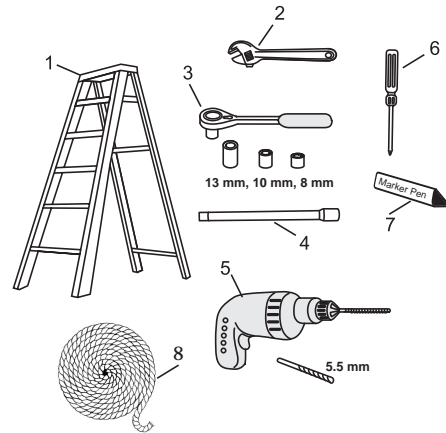

## 3 DOOR REQUIREMENTS

The HandyLift Deluxe 2.0 (CR675EVO) is suitable for spring balanced Residential Rolling garage doors with:

- Maximum door height of 4.5 m
- Maximum curtain area of 16 m<sup>2</sup>
- Maximum door mass of 100 kg

\*The obstruction detection beams must be installed if the force at the edge of the closing door exceeds 400 N (40 kgf).

Door axle diameter must not exceed 35 mm.

Minimum distance from edge of curtain to edge of door bracket 45 mm

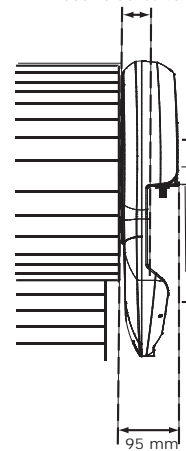

Ensure that there is at least 45 mm from the edge of the curtain to the edge of the bracket. If the roller door drum wheel is on the edge of the curtain or is a smaller diameter, additional clearance may be required.

Assemble the opener to the door axle and the existing door bracket using the U clamp assembly provided. Tighten to 25-28 Nm. Full installation process is in section 12.

## 4 CONTROL PANEL

**1. Terminal Block:** used for external accessories (see chart below).

Ref	Function	Colour	Polarity	Comment
A	Push button	Red	+ve	Dry contact input for push button wired wall controls
B	Common	White	-ve	Common terminal for push button, obstruction detection beams & accessory power
B	Common	White	-ve	Common terminal for push button, obstruction detection beam & accessory power
C	Obstruction Detection Beams	Grey	+ve	Obstruction detection beam Input (pulsing type only) - see section 16
D	Accessory Power	Green	+ve	24v dc 50 mA accessory output available for a universal receiver (output not active in Standby Mode)

**NOTE:** The terminal block is behind a plastic cover in the back housing. Use a small screwdriver to lever open the plastic cover if access to the terminal block is required. All wires should be secured appropriately.

**2. DN Button:** used to drive the door DOWN

**3. UP Button:** used to drive the door UP

**4. P Button:** used to "PROGRAM" the DOOR LIMITS (see section 13)

**5. S Button:** used to "SAVE" and "DELETE" the "REMOTE CONTROLS" (see section 19)

**6. LEDs:** 1. Program DOWN, and Diagnostic code indicator Number 1  
2. Program UP indicator  
3. Diagnostic code indicator Number 2

**7. Control Button:** Used to activate the door when remote controls are not available. Open - Stop - Close.

**8. Courtesy Light:** turns on during operation and automatically turns off after a period of 3 minutes

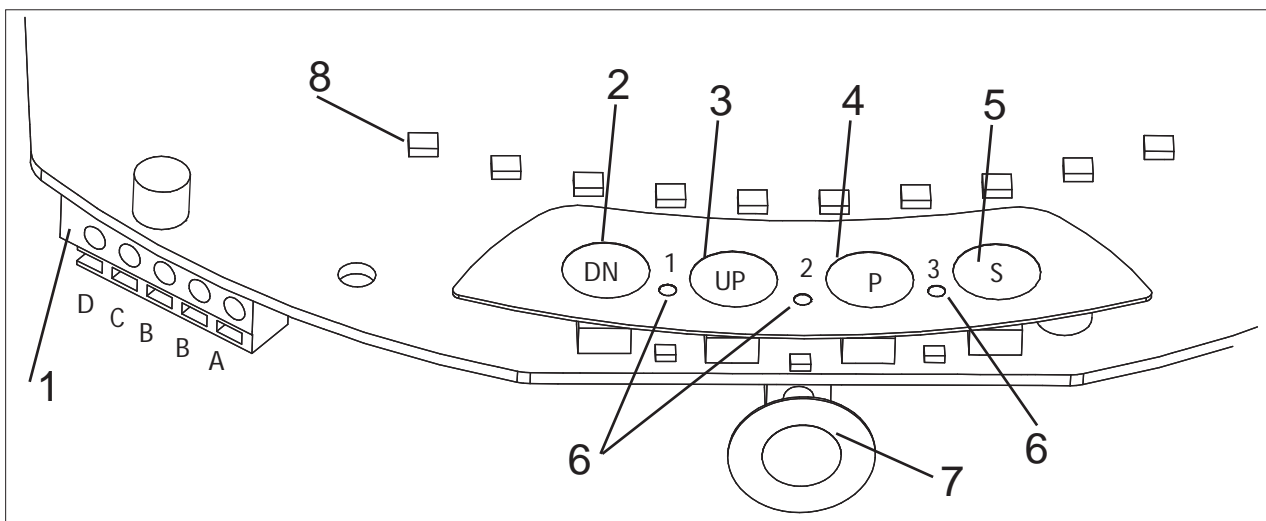

## 5 TESTING THE DOOR

Complete the following test to ensure your door is well balanced, and not sticking or binding:

- Disable all locks and remove any ropes connected to the garage door.
- Lift the door to about halfway and then release it. The door should remain spring balanced.
- Raise and lower the door to determine if there are any sticking or binding points (15 kgf is the absolute maximum allowable to raise or lower the door in any position).

If your door does not hold in place or the door binds or sticks, call a qualified door technician before installing the opener.

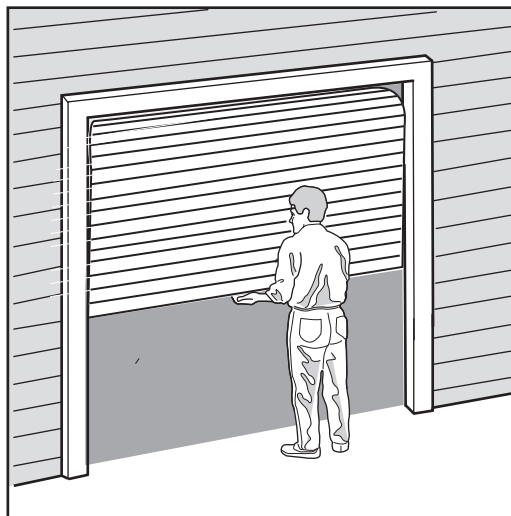

## 6 ATTACHING THE STOP COLLAR

- The stop collar (inset 1) is required to be installed on the opposite side of the door to where the opener is to be installed.
- Ensure the U-Bolt holding the door shaft to the door bracket is tightly secure.

(NOTE: This U-Bolt must not be removed or loosened)

- Remove the bolt assembly from the plastic stop collar. Open the collar as wide as possible and push it onto the door shaft.
- Fit the stop collar hard against the boss of the door drum. Reinstall the bolt assembly onto the stop collar and tighten.

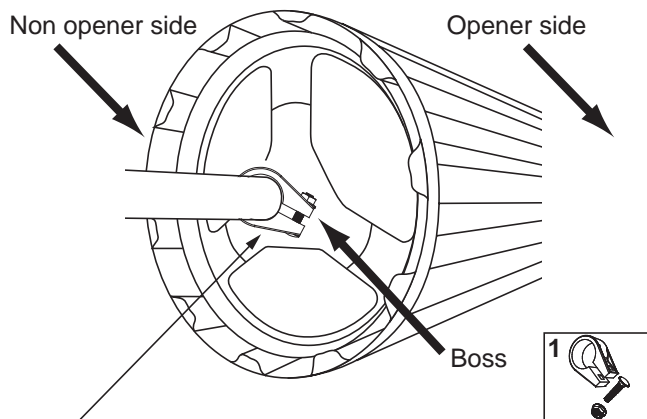

### SAFETY CHECK!

Is the stop collar installed?  
YES: proceed to the next step

NO: install the stop collar before proceeding

## 7 ATTACHING THE WEIGHT BAR

If the door has a lifting handle, remove the handle, nuts & bolts. Place the weight bar over the handle holes, insert the extended bolts through the weight bar & fasten the handle back in place.

- Place the weight bar in the centre of the door as shown.

If the door curtain does not have a handle you will need to follow these instructions:

- Use a marker pen to mark the two hole positions.
- Drill two 5.5 mm holes through the two marked positions, then place the weight bar on the inside of the door.
- Use the bolts, washers and nuts (provided - inset 2) to fasten the weight bar in place.

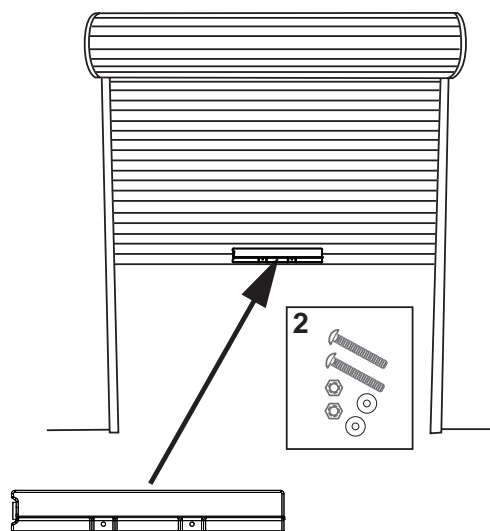

## 8 THE RELEASE HANDLE & CORD



**Do not disengage the opener to manual operation with children, persons or other objects including motor vehicles within the doorway. The door is under significant tension and if the door has developed a fault or incorrect tension, it may be unsafe and may fall rapidly.**

The manual release mechanism enables the door to be manually operated during power outages or in an emergency.

The RED Manual Release cord is preassembled to the opener. When the opener is installed the handle should be no higher than 1.8 metres from the floor. The cord may need to be extended for high door installations.

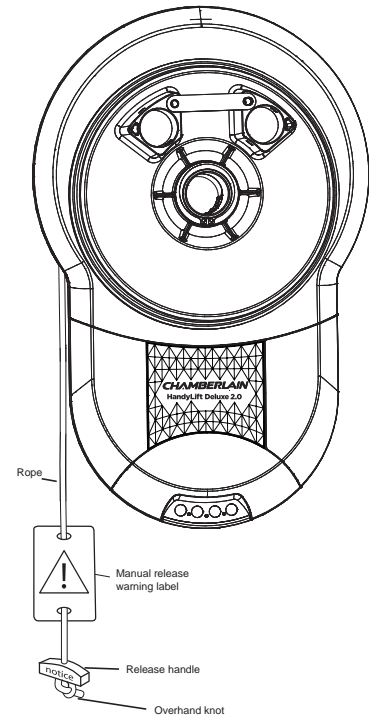

## 9 OPERATING THE MANUAL RELEASE

### To disengage the opener

Pull the release cord down firmly, (the opener will make a clicking noise).

### To re-engage the opener

Pull the release cord down firmly, (the opener will make a clicking noise).

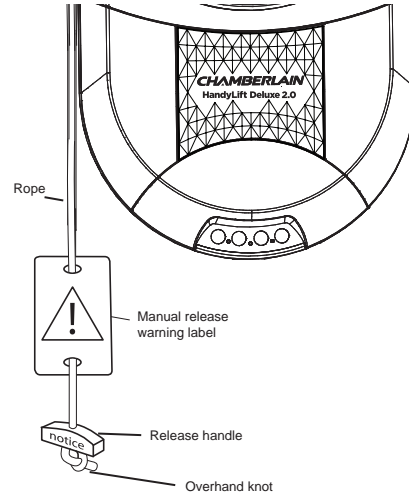

**Disable all locks and remove any ropes connected to the garage door.**

**Take care when operating the manual release as an open door may fall rapidly due to weak or broken springs, or being out of balance.**

## 10 PINNING THE DOOR

**Note: A ballooning door may delay the safety reversal response and can compromise garage door security.**

- To remedy any ballooning, insert the supplied self tapping metal screws (inset 3) into where the curtain leaves the roll. Secure these through the curtain into the drum wheel at each end of the roll.
- After determining the correct fastener location as shown, lift the door approximately half a turn from the closed position to allow access for securing the screws.

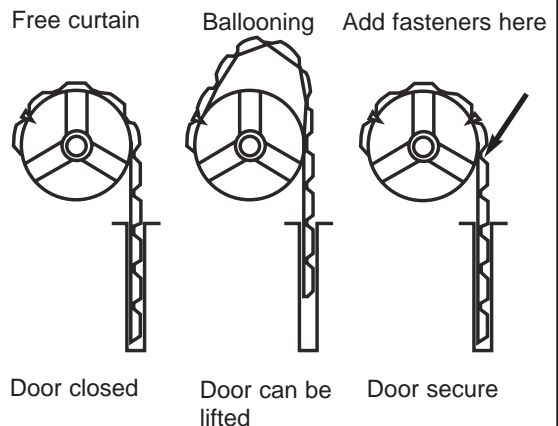
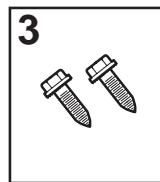

**11 LEFT / RIGHT HAND INSTALLATION**

LEFT  
(handing must  
be changed  
during limit  
setting - refer to  
section 13)

RIGHT  
(factory  
default  
setting)

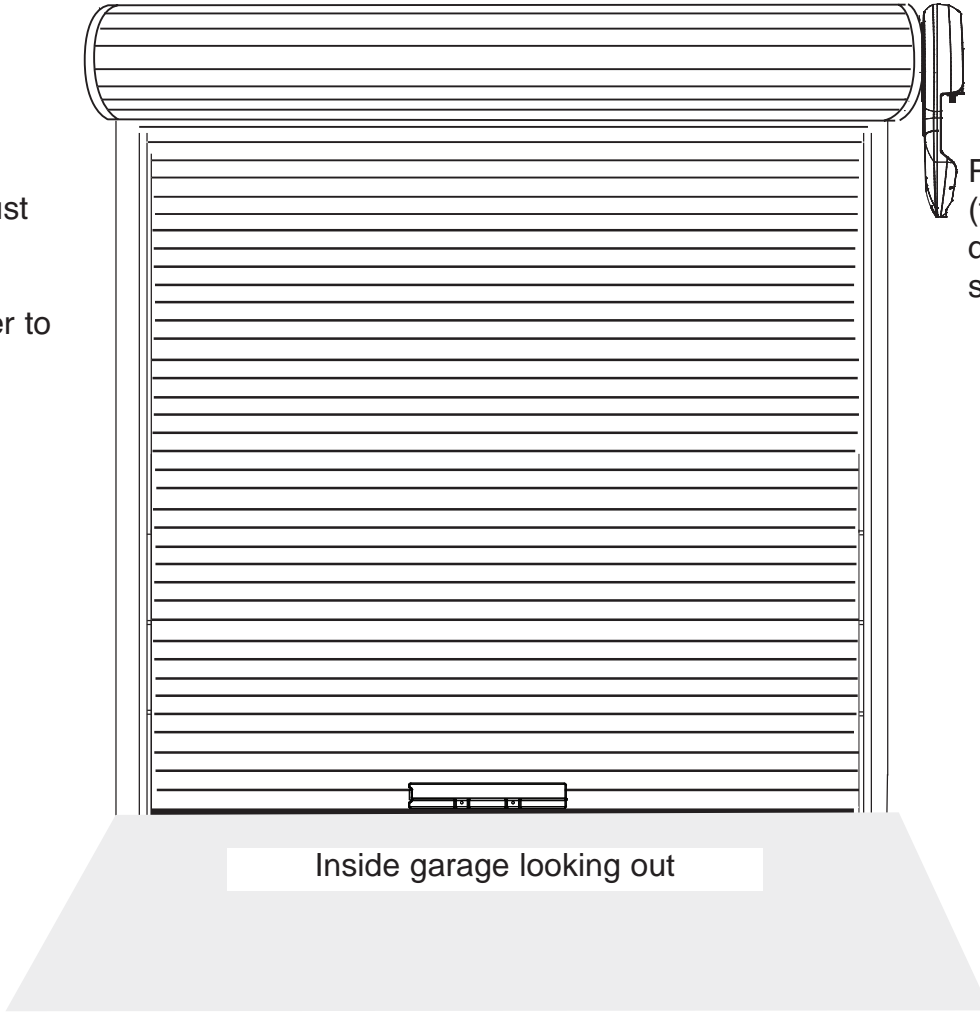

Inside garage looking out



## 12 INSTALLATION PROCEDURE



**Do not allow people to walk under or around the door during the installation process as serious injury can occur.**

**NOTE:** The opener can be installed on either side of the door. The following instructions are for **RIGHT HAND INSTALLATIONS** (as illustrated i.e. inside the garage looking out). For left hand installations, reverse the instruction terminology (eg LEFT for RIGHT etc).

### Preparation:

- Place the opener in manual release mode (refer to section 10)
- Completely open the roller door. For safety, tie a rope around the door
- Ensure the door axle U-BOLT and door mounting bracket on the left hand side (non opener side) are securely fastened
- Support the door with a door stand, ladder or similar device to safely support the door
- Mark the position of the door shaft on the right hand door bracket (for reassembly purposes)
- While the door is supported, remove the right hand axle U-Bolt and door mounting bracket from the wall

### Install the opener:

- Slide the opener over the door axle and engage the drive legs into the door drum wheel, either side of a spoke
- Refit the door mounting bracket to the wall
- Clamp the opener on the door axle and door bracket (inset 4) in the marked position using the clamp assembly supplied (tighten to 25 – 28 Nm)
- Remove all ropes and the support stand
- Check the operation of the door in manual mode by raising and lowering by hand. It should operate smoothly without sticking or binding. The disengage handle should already be attached less than 1.8m above the floor



### Connect the power:

- Position the power cable away from the door curtain and any moving parts
- Plug the opener into a nearby power point and turn ON
- The opener light will turn ON and remain ON for 3 minutes

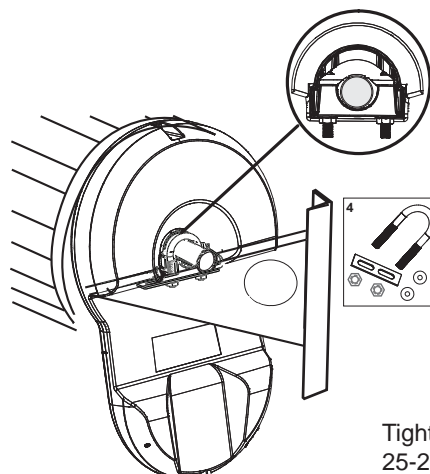
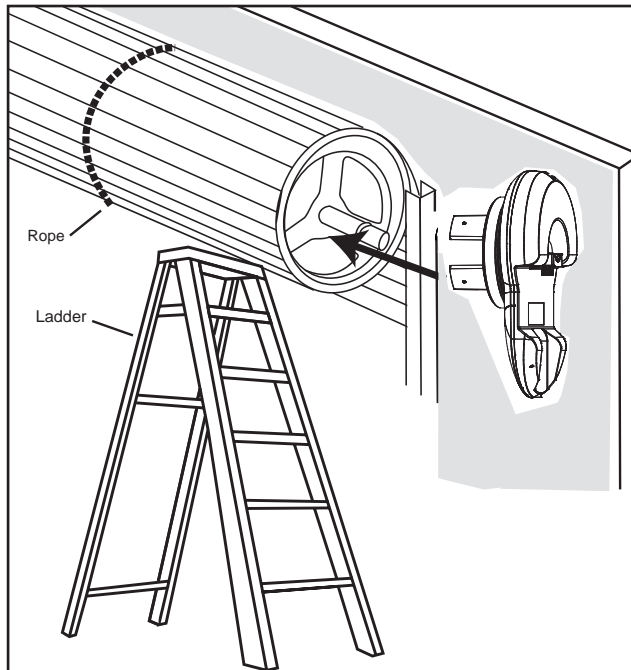
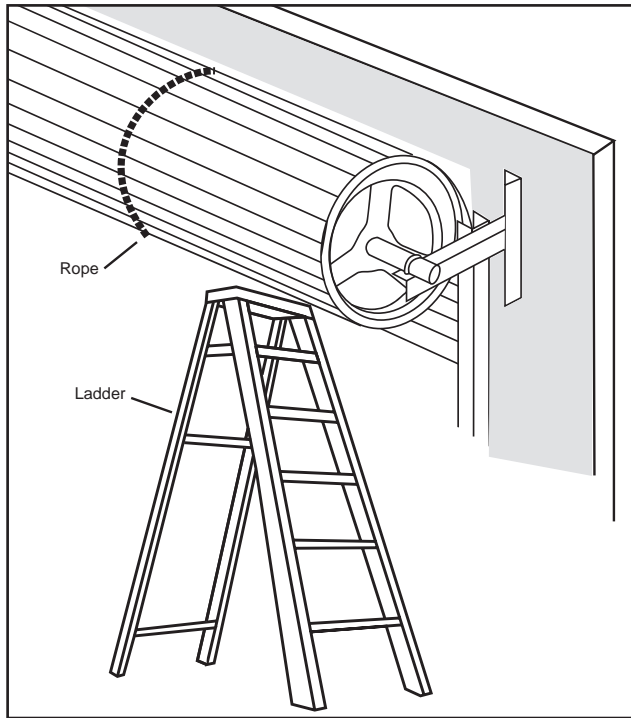

## 13 SETTING THE LIMITS FOR RIGHT OR LEFT HAND OPERATION AND FORCE

Travel limits set how far your door goes up and down. Your opener must also be configured for right or left hand installation. If not the door will rotate in the reverse direction.

**Program Buttons:** The Control Panel diagram in section 4 identifies the Control Buttons and LED layout

**Audible BEEP:** An audible "BEEP" also occurs with each button press. This feature can be turned OFF

**Courtesy light:** During the programming sequence, the courtesy light will flash at half strength

**NOTE: The HandyLift Deluxe 2.0 (CR675EVO) opener is factory configured for right hand installation.**



**The opener will operate during this procedure. Make sure the door is clear of obstruction. Ensure your hands are away from any moving parts before activating the door.**

### Setting the Right or Left Hand Operation:

Refer to the diagrams on the right for guidance. Ensure the door is positioned halfway and the opener is engaged (out of manual mode). Turn the opener Power **ON**, the courtesy light will turn ON.

1. Press the "P" button for 5 seconds until LED 3 will flash, as well as LED 2 or LED 1 will flash. For Right Hand setting LED 2 will flash, and for Left Hand setting LED 1 will flash.
2. To change to the opposite setting, simply press the "S" button, and the opposite LED will flash.
3. When the correct hand setting is selected, Press and Release the "P" program button to accept this setting. (continue)

### Setting the Door Limits:

4. Press and hold the "UP" button until the door reaches the desired OPEN position (You can toggle between the "UP" and "DN" buttons to move the door to the correct position. Make sure there is enough room for your vehicle to pass under)
5. Press and release the "P" program button to accept this setting.
6. Press and hold the "DN" button until the door reaches the desired CLOSED position (You can toggle between the UP and DN buttons to move the door to the correct position.)
7. Press and release the "P" program button to accept this setting. (LED 2 should flash to indicate you are now in Force Learn mode) (continue)

### Setting the Force Automatically:

8. Press and release the "UP" button. The door will travel to the OPEN position with LED 2 flashing.
9. Press and release the "DN" button. The door will travel to the CLOSED position with LED 1 flashing. When fully closed, LED 1 will stop flashing and the courtesy light will change to full power. (This process is now complete)

### Setting the Force manually: (Only perform if Limits are already set)

- Start with the door fully CLOSED.
- Press the "S" button twice to enter into force learn mode. The Courtesy light will go to half strength, and Led 2 will flash quickly.
- Press and release the "UP" button. The door will travel to the OPEN position, then LED 1 will flash quickly.
- Press and release the "DN" button. The door will travel to the CLOSED position, then LED 1 will stop and the courtesy light will change to full power.

This process is now complete.

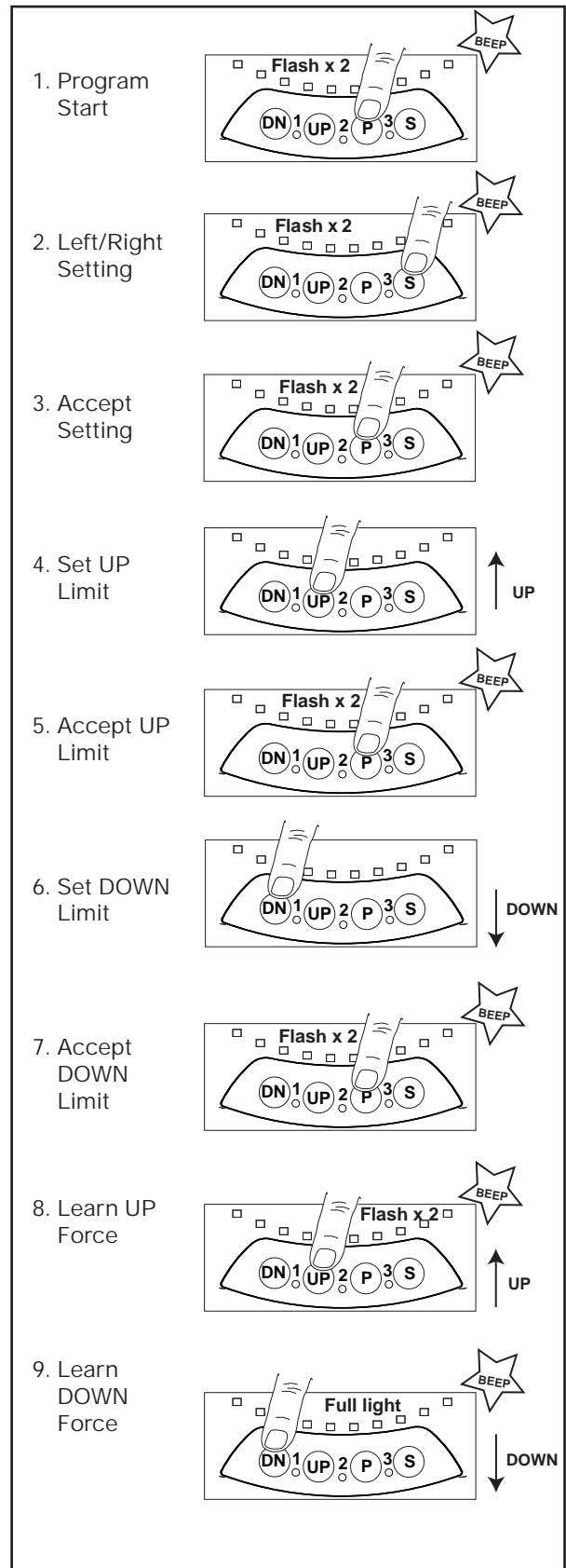

## 14 TESTING THE SAFETY REVERSE SYSTEM



The safety reverse system test is important. The garage door must reverse on contact with a 40 mm obstacle laid flat on the floor. Failure to properly adjust the opener may result in serious personal injury from a closing garage door.

Operate the door in the down direction. The door must reverse upon contact with the obstacle. If the door stops on the obstacle, remove obstacle and repeat limit and force setting (refer to section 13).

**Repeat the safety reverse system test.**

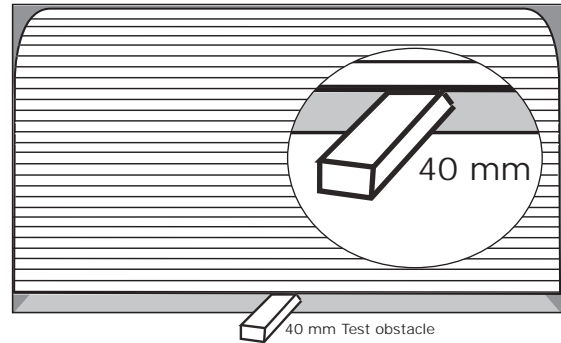

## 15 FIXING WARNING LABELS

Once you have completed your installation and successfully carried out the safety reverse system test (outlined above), install the warning labels provided with your opener as shown.

The **risk of entrapment label** must be installed adjacent to the release handle at a height of less than 1.8 m from the floor.

The **WARNING** label must be installed in a prominent place near any fixed control.

Any fixed wall control or wireless door control must be mounted at a height of no less than 1.5 m **out of the reach of children**.

Read the safety instructions (page 1) for further details concerning safety.

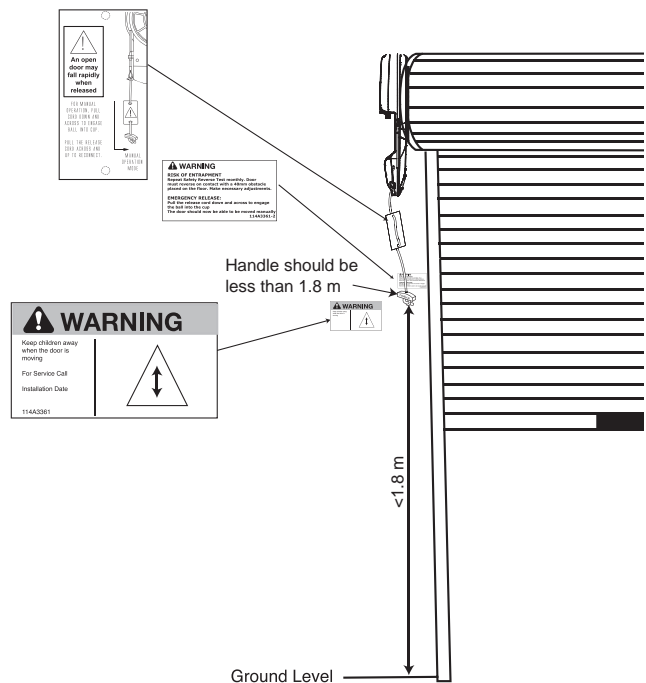

**STANDARD INSTALLATION COMPLETE**

## 16 INSTALLING OBSTRUCTION DETECTION BEAMS (OPTIONAL ACCESSORY)

**NOTE:** This accessory must be used for all installations where the closing force as measured on the bottom of the door is over 400 N (40 kgf).

After the opener has been installed and adjusted, obstruction detection beams can be installed. Instructions are included with this accessory.

The obstruction detection beams provide an additional measure of safety against a small child or animal being trapped under a garage door. It uses an infra-red beam, which when broken by an obstruction, causes a closing door to stop and open, preventing an open door from closing and is **strongly recommended for homeowners with young children or pets.**

### ENABLING the obstruction detection beams:

- Connect the obstruction detection beam wiring to the opener and turn ON. (The obstruction detection beams will automatically enable once they are connected and will now operate in a FAIL SAFE mode.)

### DISABLING the obstruction detection beams:

If the obstruction detection beams are installed and needs to be removed the opener will need to be reprogrammed.

Perform the power ON/OFF sequence as follows

- Remove the obstruction detection beam wires from the opener
- Turn the mains power OFF for 5 seconds
- Turn the power ON for 5 seconds
- Turn the power OFF for 5 seconds
- Turn the power ON and check the opener operates OK without the obstruction detection beams

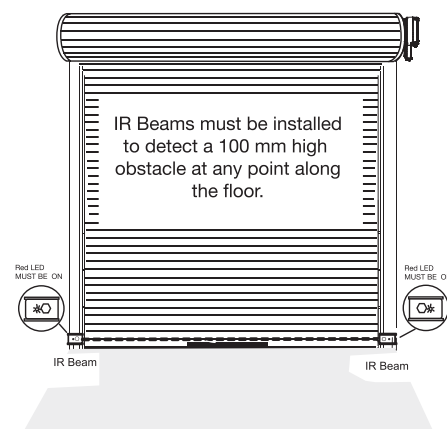

### SAFETY FIRST!



Whilst Chamberlain have engineered safety features into your garage door opener, we urge you to consider fitting obstruction detection beams to your new garage door opener. In many countries these devices are compulsory to assist in preventing serious injury or property damage. For your own peace of mind and the safety of others please consider installing this safety device.

### Timer to close feature (TTC)

**Auto close is NOT recommended for households with young children.**

**TIMER TO CLOSE feature: (TTC) 10 to 180 seconds.**

**NOTE: Obstruction detection beams must be installed before TTC will operate.**

The Timer to Close feature allows the door to automatically close after a specified time period. During the OPEN door waiting period, the courtesy light will flash continuously.

If the door encounters an obstruction while closing, the opener will return to the OPEN position and the waiting period will begin again.

#### To activate the Timer to Close:

- Start with obstruction detection beams installed and the door fully CLOSED
- Press and Hold both “P” and “DN” buttons for 3 seconds. When the Courtesy light flashes “TWICE”, release both buttons
- Press the “UP” for each 10 second interval required for Timer to Close. A “BEEP” will register for each press. “DN” button will reduce the count if needed.
- Press and release the “P” button to accept this setting

#### To deactivate the Timer to Close:

- Start with the door fully CLOSED
- Press and Hold both “P” and “DN” buttons for 3 seconds. When the Courtesy light flashes “TWICE”, release both buttons.
- Press and release the “P” button to accept this setting

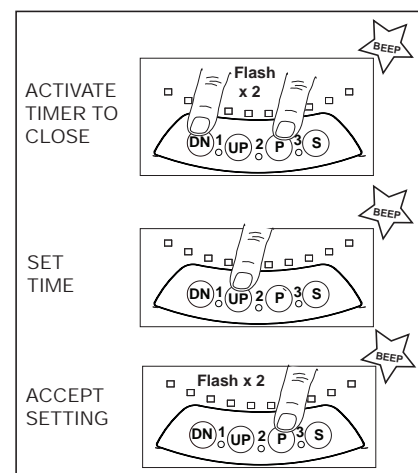

**The door may operate unexpectedly, therefore do not allow anything to obstruct the path of the door.**

## 17 AUDIBLE BEEP (OPTIONAL)

The HandyLift Deluxe 2.0 (CR675EVO) has been factory set for an audible “BEEP”.

The Audible beep can be turned OFF by using the following method.

- Start with the door fully CLOSED.
  - Press and Hold both “S” and “DN” buttons for 3 seconds
  - The Courtesy light will flash “TWICE”.
- Release the buttons.

To turn the audible beep back ON, simply repeat the above process.

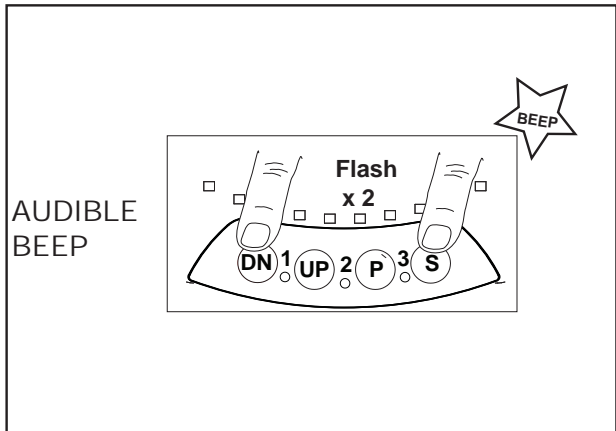

## 18 VENTILATION MODE - PARTIAL OPENING FEATURE

This is an adjustable, second stop position, that can be pre-set, partially open for ventilation, pedestrian or pet access, programmed to the Remote Control.

### To activate the ventilation mode:

1. Start with the door fully **CLOSED** (figure 1). Drive the opener **UP** and stop at the position required for you wish to set the door at.
2. Enter ventilation activation mode by pressing the **P** and **UP** buttons together for 3 seconds (figure 2). Release when the courtesy light flashes once.
3. Press the remote control button that you have allocated for this feature (figure 3). Do not use the button already allocated for normal operation. The courtesy light will flash when the code is accepted.

The remote will now operate to and from the “programmed” and the “fully closed position”. Outside this range the remote will operate as normal.

### To deactivate the partial opening feature:

1. Start with the door fully **CLOSED**.
2. Enter ventilation mode by pressing the **P** and **UP** buttons together for 3 seconds (figure 2). The courtesy light will flash twice, indicating that deactivation has occurred.

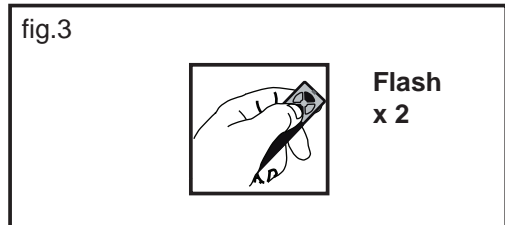
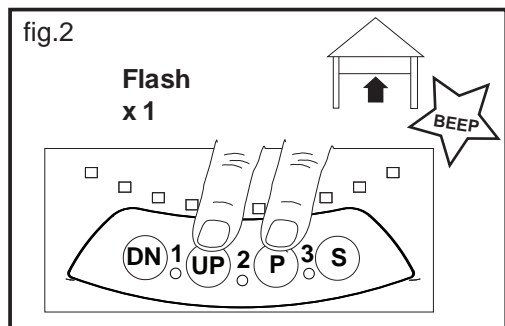
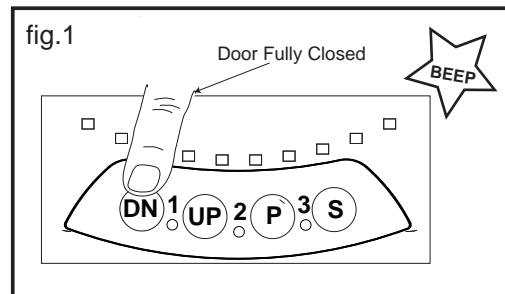

## 19 WIRELESS PROGRAMMING (REMOTE ACCESSORIES)

**NOTE:** The transmitters supplied with your opener are preprogrammed by the factory.



**Activate the opener only when door is in full view, free of obstruction and properly adjusted. No one should enter or leave the garage while the door is in motion. Do not allow children to operate push buttons or remotes. Do not allow children to play near the door.**

If you purchase additional transmitters, the garage door opener must be programmed to accept the new remote code.

**Program the receiver to match additional transmitter codes:**

**Using the “S” SAVE Button**

1. Press and hold the button on the remote that you wish to use (1)
2. Press and release the “S” button on the opener (2)
3. Release the remote button when the courtesy light flashes twice. It has learnt the code. If you release the remote control push button before the opener light flashes, the opener has not learnt the code.

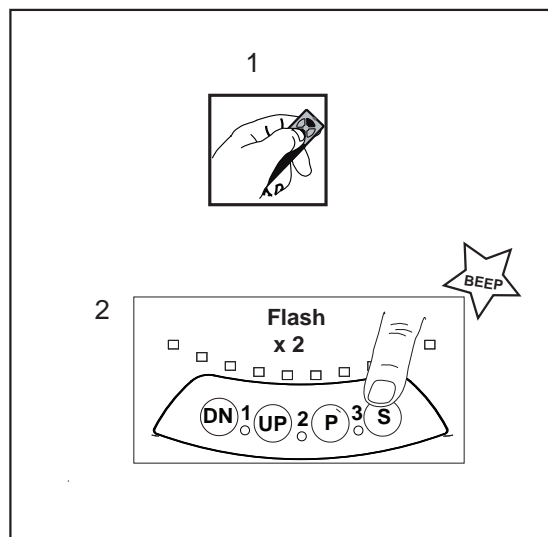

The opener will now operate when the remote control button is pressed.

**To Erase all Remote Control Codes**

1. Press and hold the “S” button on the opener until the courtesy light flashes twice, and continue holding for approximately 8 seconds, until the courtesy light flashes twice again.
2. Release the button, all codes are now erased.

## 20 STANDBY MODE (OPTIONAL)

**The HandyLift Deluxe 2.0 has been factory set for low standby mode (sub 1 watt usage).**

This will deliver the lowest possible standby power. The External Accessory Power is turned OFF in this mode, so if this output is required, Normal Standby mode will need to be activated (eg. for using an external receiver).

**To Activate NORMAL STANDBY mode:**

- Turn the mains power OFF.
- Press and Hold both “UP” and “DN” buttons.
- Turn ON mains power while both buttons are still pressed.
- Courtesy light comes ON, and after 5 seconds another 10 flashes. Release both buttons.

**To Activate LOW STANDBY mode:**

- Turn the mains power OFF.
- Press and Hold both “UP” and “DN” buttons.
- Turn ON mains power while both buttons are still pressed.
- Courtesy light comes ON, and after 5 seconds another 1 flash. Release both buttons.

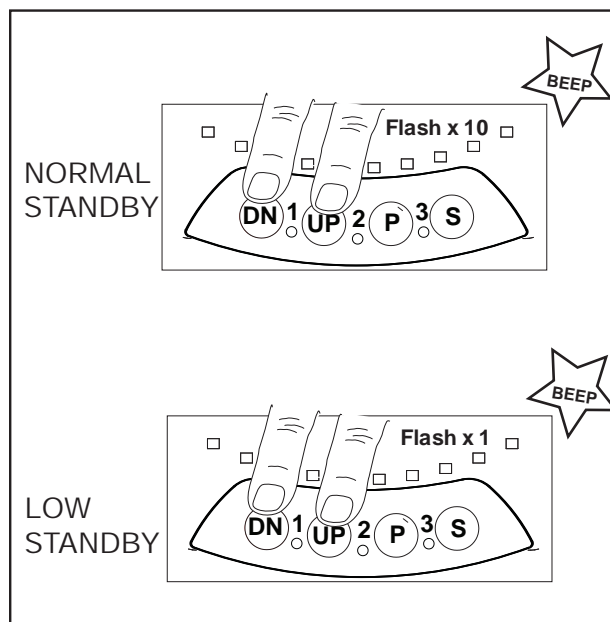

## OPERATION OF YOUR OPENER

Your opener can be activated by any of the following devices:

- **Opener Control Panel:** UP & DOWN buttons, and O.S.C. control button.
- **Remote Control Transmitter:** hold the button down until the door starts to move.
- **Wireless Entry Keypad:** This is an optional accessory that opens the door using a four digit keycode.

### When the opener is activated:

- If open, the door will close. If closed, the door will open
- If closing, the door will stop
- If opening, the door will stop (allowing space for entry and exit of pets and for ventilation)
- If the door has been stopped in a partially open or closed position, it will reverse direction

### Obstruction behaviour:

- If an obstruction is encountered while closing, the door will reverse
- If an obstruction is encountered while opening, the door will reverse and stop
- Obstruction detection beams use an invisible beam which, when broken by an obstruction, causes a closing door to open and prevents an open door from closing. It is **STRONGLY RECOMMENDED** for homeowners with young children or pets.

### Opening the door manually:



**When releasing the door, the door should be fully closed if possible. Weak or broken springs could allow an open door to fall rapidly. Property damage or serious injury could result.**

The door can be opened manually by pulling the release cord down firmly.  
To re-engage the door, pull the release cord down firmly.

**The opener light will turn on for 3 minutes when the opener is activated.**

## CARE OF YOUR OPENER

When properly installed, your opener will operate with minimal maintenance. The opener does not require additional lubrication.

**Limit and Force Settings:** These settings must be checked and properly set when the opener is installed. Weather conditions may cause some minor changes in the door operation, requiring some re-adjustments, particularly during the first year of operation. Refer to limit and force setting in, section 13.

**Follow the instructions carefully and repeat the safety reverse test after any adjustment.**

**Transmitter:** Additional transmitters can be purchased at any time. Refer to [chamberlaindiy.com.au](http://chamberlaindiy.com.au) or [chamberlaindiy.co.nz](http://chamberlaindiy.co.nz) for compatible transmitters. Any new transmitters must be programmed into the opener.

**Transmitter battery:** If the transmission range decreases, replace the battery.

## MAINTENANCE OF YOUR OPENER

### Once a Month:

- Repeat the safety reverse test (see section 14). Make any necessary adjustments.
- Manually operate the door. If it is unbalanced or binding, call for professional garage door service.
- Check to be sure that the door opens and closes fully.  
Set the limits and/or force if necessary.

## SPECIFICATIONS HANDYLIFT DELUXE 2.0 (CR675EVO)

Input Voltage:	220-240 VAC, 50-60 Hz, 140 W
Rated Load:	35 Nm
Max. Pull Force:	500 N @ Ø300 mm
Max. door weight:	100 kg
Max lift under Spring Tension:	15 kg
Max. door area:	16 m <sup>2</sup>
Standby Power:	<1 watt
Drive:	DC gear motor permanent lubrication
Max. Drum Rotations:	4 <sup>1</sup> / <sub>2</sub>
Memory Registers:	64
Operating Frequency:	433.30/433.92/434.54 MHz
Operating Temperature:	55°C to -25°C

**SPECIAL NOTE:** Chamberlain strongly recommends that obstruction detection beams be installed on all garage door openers.

## 21 TYPICAL WIRING DIAGRAM HANDYLIFT DELUXE 2.0 (CR675EVO)

### Information for Service Personnel

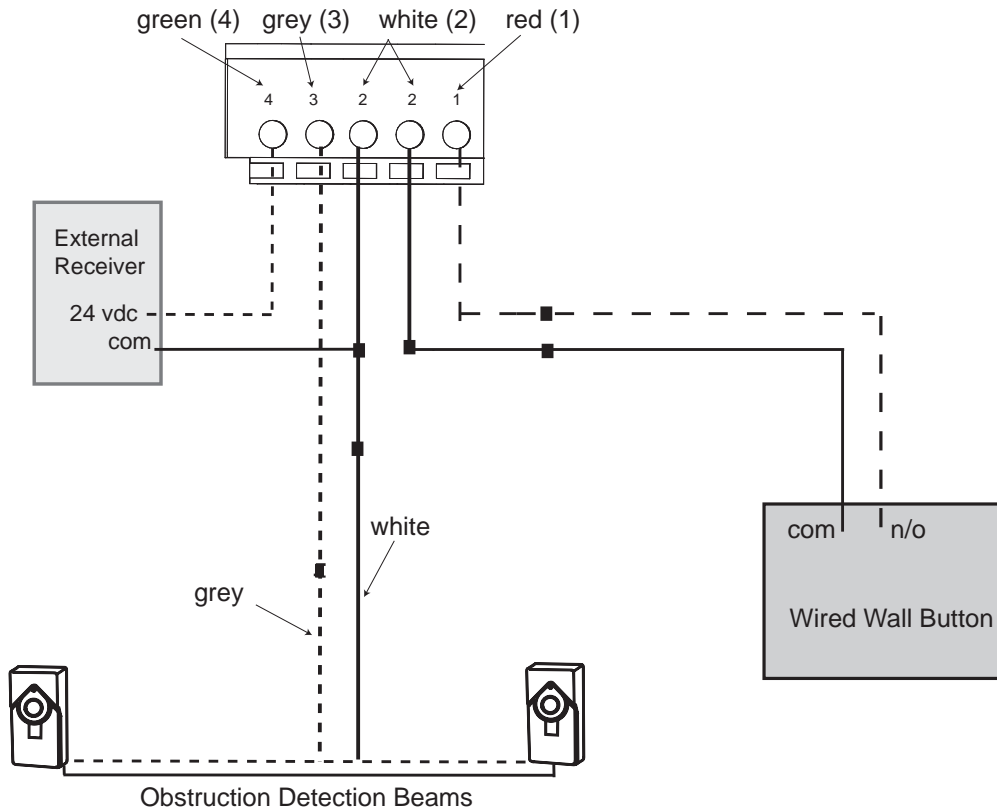

## 22 REPLACE BATTERIES IN REMOTES

### Battery of the remote control:

The batteries in the remote have a long life.

If the transmission range decreases, the batteries should be replaced. Batteries are not covered by the warranty.



**To prevent SERIOUS INJURY OR DEATH: observe the following instructions for the battery**

- NEVER allow small children near batteries.

- If battery is swallowed, immediately notify a Doctor.

- Danger of explosion if battery is replaced improperly.
- Replacement only by identical or equivalent type.
- Dispose of old battery properly. Batteries should not be treated as household waste. All consumers are required by law to dispose of batteries properly at the designated collection points.
- Never recharge batteries that are not meant to be recharged.
- Do not short-circuit batteries or take them apart.
- If necessary, clean contacts on batteries and contacts before loading.
- Never expose batteries to excessive heat such as sunshine, fire or the like!

### Replacing battery (CR2032 or equivalent):

To replace the battery, turn the remote control around and open the case with a screwdriver. Lift the cover and lift the control board. Slide the battery to one side and remove the old battery. Be sure to observe the polarity of the battery.

Assemble the transmitter again following the steps in reverse.





## **23 TROUBLESHOOTING**

### **1. The opener will not operate from either the UP/DOWN activation button or the transmitters :**

- Does the opener have electric power? Plug a lamp into the outlet. If it does not work, check the fuse box.
- Have you disabled all door locks? Review the installation instruction warnings on page 1.
- Is there a build-up of ice or snow under the door? The door may be frozen to the ground. Remove any restriction.
- The garage door spring may be broken. Have it replaced by contacting a garage door repairer.

### **2. Opener operates from the transmitter, but not from the wired wall control terminals:**

- Check that the wiring connections are correct.

### **3. The door operates from the UP/DOWN activation buttons but not from the wireless wall control or transmitter:**

- Program the opener to match the transmitter code. Repeat with all transmitters.

### **4. The transmitter has short range:**

- Change the location of the transmitter.
- Check to be sure the antenna on the bottom of the opener extends fully downward.
- Some installations may have shorter range due to a metal door, foil backed insulation, or metal garage siding.
- The batteries may be flat. Replace the batteries.

### **5. The garage door opens and closes by itself:**

- Be sure that no transmitter buttons are being pressed.
- Clear the memory and re-program all wireless wall controls and transmitters.

### **6. The door reverses and stops before opening completely:**

- Is something obstructing the door? Is it out of balance, or are the springs broken? Remove the obstruction or repair the door.

### **7. Door reverses for no apparent reason and opener lights flash 10 times:**

- Check the obstruction detection beams (if you have installed this accessory). If the red light on the beam is flashing, the alignment is incorrect.
- The red light on the beams may not be on if the opener is in Standby mode. Activate the door to temporarily exit standby mode and check lights are on constantly. If the LEDs are flashing, realign the beams.

### **8. The door opens but will not close (or reverses while closing):**

- Is something obstructing the door? Pull the manual release handle. Operate the door manually. If it is unbalanced or binding, call a trained door systems technician.
- Clear any ice or snow from the garage floor area where the door closes.
- Repeat the limit and force setting. Repeat safety reverse test after adjustments.

### **9. The opener strains to operate the door:**

- The door may be out of balance or the springs may be broken. Close the door and use the manual release to disconnect the door. Open and close the door manually. A properly balanced door will stay in any point of travel while being supported entirely by its springs. If it does not, disconnect the opener and call a trained door systems technician.

### **10. The opener motor hums briefly, then will not work:**

- Check that the door is not in manual release mode (refer to section 6).
- The garage door springs may be broken.
- If the problem occurs on the first operation of the opener, the door may be locked. Disable any door locks.

### **11. The opener will not operate due to a power failure:**

- Use the manual release handle to disconnect the door. The door can be opened and closed manually. When power is restored, re-engage the opener to operate it via a transmitter.

### **12. The LED Indicators on the control panel are flashing in sequence:**

- Check the diagnostic code on the next page.

## 24 ACCESSORIES

1. Model E940C Car visor remote
2. Model E950C Key ring remote
3. Model E840C Wireless keypad - open the garage door with a four button key code

4. Model 1702AML Outside quick release
5. Model 774AML Obstruction detection beams - safety beams to protect your family, pets and property from a closing door

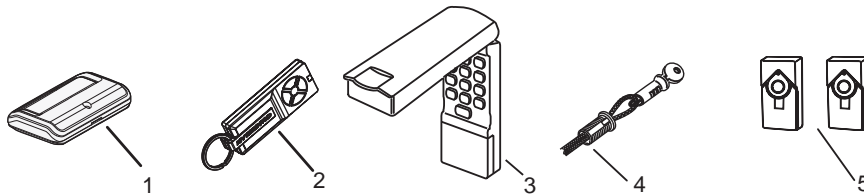

## 25 DIAGNOSTIC CHART

Your garage door opener is programmed with self-diagnostic capabilities. The indicator LED's 1 & 3 on the control panel will flash a number of times to indicate a fault code exists.

DIAGNOSTIC CODE		SYMPTOM	POSSIBLE RESOLUTION
LED 1	LED 3		
1	1	The garage door opener will not close and the courtesy light flashes.	Safety sensors are open circuit or wires may be cut. Inspect sensor wires for a disconnected or cut wire. Turn power off and reboot the opener.
1	2	The garage door opener will not close and the courtesy light flashes.	There is a short circuit wire for the safety sensors. Inspect safety sensor wire at all staple points and replace wire or correct as needed. Turn power off and reboot the opener.
1	3	The door control will not function.	The wires for the door control are shorted or the door control is faulty. Inspect safety sensor wire at all staple points and connection points and replace wire or correct as needed.
1	4	The garage door opener will not close and the courtesy light flashes.	Safety sensors are misaligned or were momentarily obstructed. Realign both sensors to ensure both LEDs are steady and not flickering. Make sure nothing is hanging or mounted on the door that would interrupt the sensors path while closing.
1	5	There is no door movement or motor accelerates before stopping suddenly.	No RPM pulses have been detected. Check the door manually for balance, binding or obstructions. Internally the possible cause may be the motor, logic board or RPM sensor. Try resetting door travel limits. Contact service centre.
2	1	Opener fails to operate.	Possible PCB memory failure. Reboot opener by turning the mains power OFF and then ON after 15 seconds. Reprogram the door travel limits and force settings. Contact service centre.
2	2	Opener fails to operate.	Possible PCB Voltage failure. Reboot opener by turning the mains power OFF and then ON after 15 seconds. Reprogram the door travel limits and force settings. Contact service centre.
2	4	Opener fails to operate using the remote controls	Possible receiver failure. Reboot opener by turning the mains power OFF and then ON after 15 seconds. Recode the transmitters. Contact service centre.
4	1	Door is moving down, stops and reverses.	Manually open and close the door. Check for binding or obstructions, such as a broken spring or door lock. If the door is binding or sticking contact a trained door systems technician. If door is not binding or sticking, reset the limits (refer to "Program the Travel Limits and Force" section).
4	2	Door is moving up, stops and reverses.	Manually open and close the door. Check for binding or obstructions, such as a broken spring or door lock. If the door is binding or sticking contact a trained door systems technician. If door is not binding or sticking, reset the limits (refer to "Program the Travel Limits and Force" section).

## CHAMBERLAIN LIMITED WARRANTY

### Chamberlain® HandyLift® Deluxe 2.0 CR675EVO

Chamberlain Australia Pty Limited / Chamberlain New Zealand Limited (Chamberlain), the manufacturer of Chamberlain automatic garage door openers is committed to manufacturing and supplying high quality goods. As part of this commitment, we seek to provide reliable service and support for our goods and are pleased to provide you, the original purchaser, with this Chamberlain Limited Warranty.

The benefits given to you under this Chamberlain Limited Warranty are in addition to any rights and remedies that you may have under Australian or New Zealand consumer protection laws. Our goods come with guarantees that cannot be excluded under the Australian Consumer Law, or New Zealand Consumer Guarantees Act 1993. You are entitled to a replacement or refund for a major failure and for compensation for any other reasonably foreseeable loss or damage. You are also entitled to have the goods repaired or replaced if the goods fail to be of acceptable quality and the failure does not amount to a major failure.

### Chamberlain's warranty

#### What is covered

Chamberlain warrants to the original purchaser of the Chamberlain HandyLift Deluxe 2.0 CR675EVO Roller Door Opener (Unit) that it is free from defects in materials and workmanship for a period of 5 years (60 months) or 10,000 cycles (each opening & closing of the garage door equals 1 cycle) whichever comes first, from the date of purchase when installed in a residential premise with a residential specified garage door that is designed for the sole purpose of a single-family dwelling.

Remote controlled transmitters and accessories included with this Unit have a 12 month warranty from date of purchase. These transmitters and accessories are not covered for damage caused by neglect.

#### What is not covered

Batteries and globes are not covered under this warranty period.

#### Warranty conditions

It is a condition of this warranty that for the operating life of the Unit the garage door is operable by hand and opens and closes with no more than a maximum of 20 kg of lifting weight. It is also a condition of the Chamberlain Limited Warranty that the Unit is serviced by a professional garage door technician during the period 24 to 36 months after the purchase date. This garage door service fee will be at the consumer's expense. For assistance with finding your local garage door technician call Chamberlain on 1800 665 438.

*NB: The Australian Garage Door Association directs attention to consumers to maintain your garage door in good running order it is important your door is serviced by a professional garage door technician every 12 months or earlier as conditions may require.*

It is also a condition of the Chamberlain Limited Warranty to register your warranty by completing the online form at [www.chamberlaindiy.com.au](http://www.chamberlaindiy.com.au) or [www.chamberlaindiy.co.nz](http://www.chamberlaindiy.co.nz).

#### Making a claim

During the applicable Chamberlain Limited Warranty period, if you are concerned that the Unit may be defective, call our Customer Service Centre toll free line (AU: 1800 665 438, NZ: 0800 653 667).

Once the problem has been diagnosed, subject to your rights under the applicable Australian and New Zealand consumer protection laws with respect to major failures, Chamberlain will provide you with, at their discretion:

- a replacement Unit
- or
- repairs to the opener, Chamberlain will furnish replacement parts free of charge if non electrical.-

Repairs and replacement parts provided under this Chamberlain Limited Warranty is provided free of charge and is warranted for the remaining portion of the original warranty period.

This Chamberlain Limited Warranty provides benefits which are in addition to your other rights and remedies as a consumer.

## Exclusions - what voids the warranty

If our service centre determines that a warranty claim has been made in respect of a failure or defect arising under or out of any exclusion detailed below such that the claim is not covered under this Chamberlain Limited Warranty, we may, subject to your other rights and remedies as a consumer, charge you a fee to repair, replace and/or return the Unit to you. This Chamberlain Limited Warranty does not cover any failure of, or defect in, the Unit due to:

- 1 non-compliance with the instructions regarding specifications, installation, operation, maintenance and testing of the Unit or of any product with which the Unit is used;
- 2 any attempt by a person other than a Professional Dealer to repair, dismantle, reinstall or move the Unit to another location once it has been installed;
- 3 tampering, neglect, abuse, wear and tear, accident, electrical storm, excessive use or conditions other than normal domestic use;
- 4 problems with, or relating to, the garage door or garage door hardware, including but not limited to the door springs, door rollers, door alignment or hinges;
- 5 problems caused by electrical faults or replacement of batteries or light bulbs, blown fuses, electrical surges, power surges or power strikes, fire, flood, rain, water, lightning or storms;
- 6 water or moisture ingress that causes corrosion or electrical malfunction;
- 7 corrosion caused by sea air if located near a waterway, beach etc;
- 8 fitment to a commercial door or in a commercial operating application, installation of a residential garage door opener in a commercial or industrial premises other than a single-family dwelling.
- 9 lack of proper maintenance, service or care of the door and Unit;
- 10 any unauthorised modification to the Unit; or
- 11 damage caused by insects, pests or other after sale damage caused by events or accidents outside Chamberlain's reasonable control and not arising under normal and standard operating conditions.

NB: A General Purpose Outlet (GPO) ie: power point must be supplied by the consumer as this electrical fitting does not form a part of the Unit (opener). If this Chamberlain Limited Warranty does not apply, you may have rights available to you under the Australian and New Zealand consumer protection laws.

#### Accessories Warranty:

Accessories supplied with the Unit are warranted for 12 months from the date of installation.

#### Liability – Australia only

Except as set out in the Australian Consumer Law (being Schedule 2 of the Competition and Consumer Act 2010) (as amended, consolidated or replaced):

- 1 all other guarantees, warranties and representations in relation to the Unit or its supply are excluded to the extent that Chamberlain can lawfully exclude them; and
- 2 under no circumstances will Chamberlain be liable for consequential, incidental or special damages arising in connection with the use, or inability to use, the Unit, other than those which were reasonably foreseeable as liable to result from the failure.

#### Liability – New Zealand only

Except as set out in the Fair Trading Act 1986 and the Consumer Guarantees Act 1993 (as amended, consolidated or replaced):

- 1 all other guarantees, warranties and representations in relation to the Unit or its supply are excluded to the extent that Chamberlain can lawfully exclude them; and
- 2 under no circumstances will Chamberlain be liable for consequential, incidental or special damages arising in connection with the use, or inability to use, the Unit, other than those which were reasonably foreseeable as liable to result from the failure.

**Note: We request that you retain your sales docket or invoice as proof-of-purchase and attach it to this manual to enable you to establish the date of purchase in the unlikely event of a warranty service being required. Chamberlain reserves the right to change the design and specifications of the Unit without prior notification. Some features or accessories of the Unit may not be available in certain markets or areas. Please check with your distributor.**

## Chamberlain service centre contact details

### Australia

Phone toll free 1800 665 438  
Fax toll free 1800 888 121  
PO Box 1446, Lane Cove NSW 1595  
Website: [www.chamberlaindiy.com.au](http://www.chamberlaindiy.com.au)

### New Zealand

Auckland phone 09 477 2823  
Phone toll free 0800 653 667  
Fax toll free 0800 653 663  
Website: [www.chamberlaindiy.co.nz](http://www.chamberlaindiy.co.nz)

**Email:** [customerservice@chamberlainnz.com](mailto:customerservice@chamberlainnz.com)

# Warranty Registration

Register your warranty at:

[chamberlaindiy.com.au/warranty](http://chamberlaindiy.com.au/warranty)

or

[chamberlaindiy.co.nz/warranty](http://chamberlaindiy.co.nz/warranty)

***CHAMBERLAIN***®