



SECURITY+

Model 3800PLD GARAGE DOOR OPENER

For Residential and Light Duty Commercial Use
Install On Sectional Doors With Torsion
Assemblies Only



This product is intended for installation only by trained garage door technicians. This product may require adjustments to door springs and or track configurations. This product is not intended for use on low headroom tracks or garage doors utilizing extension springs.

- Please read this manual and the enclosed safety materials carefully!
- Fasten the manual near the garage door after installation.
- The door **WILL NOT CLOSE** unless the Protector System® and cable tension monitor are connected and properly aligned.
- Periodic checks of the garage door opener are required to ensure safe operation.
- The model number label is located behind the hinged door of your opener.
- **DO NOT** exceed 10 complete cycles of door operation per hour.

Table of Contents

INTRODUCTION	2-5	Attach the Cable Tension Monitor (Required)..... 10	Using the Remote Control..... 25
Safety Symbol and Signal Word Review ..	2	Install the Smart Control Panel®	Care of Your Garage Door Opener..... 26
Planning.....	3	Install Remote Light..... 12	Troubleshooting..... 26-27
Preparing Your Garage Door.....	4	Electrical Requirements	Smart Control Panel® Messages
Tools Needed	4	Install the EverCharge® Standby Power System (optional)..... 14	Diagnostic Chart
Specifications.....	4	Install The Protector System®..... 15-18	PROGRAMMING
Carton Inventory	5	ADJUSTMENT	30-32
Hardware Inventory.....	5	Program the Travel Limits..... 19	To Add or Reprogram a Hand-Held Remote Control (Model 895MAX)..... 30
ASSEMBLY	6-7	Set the Force..... 20	To Erase All Codes From Garage Door Opener Memory
Attach the Collar to the Garage Door Opener	6	Test the Safety Reversal System..... 21	To Add, Reprogram or Change a Keyless Entry PIN..... 31
Attach Mounting Bracket to the Garage Door Opener	7	Test The Protector System®..... 21	Programming Light or Additional Light.. 32
INSTALLATION	7-17	Test Cable Tension Monitor	REPAIR PARTS
Installation Safety Instructions.....	7	Test Power Door Lock..... 22	33-34
Position and Mount the Garage Door Opener	8	To Open Door Manually	Installation Parts
Attach the Emergency Release Rope and Handle.....	9	OPERATION	Garage Door Opener Assembly Parts..... 34
Install Power Door Lock.....	9	23-29	ACCESSORIES
		Operation Safety Instructions..... 23	35
		Using Your Garage Door Opener..... 23	REPAIR PARTS AND SERVICE
		Using the Smart Control Panel®	36
			WARRANTY
			36

Introduction

Safety Symbol and Signal Word Review

This garage door opener has been designed and tested to offer safe service provided it is installed, operated, maintained and tested in strict accordance with the instructions and warnings contained in this manual.

When you see these Safety Symbols and Signal Words on the following pages, they will alert you to the possibility of **serious injury or death** if you do not comply with the warnings that accompany them. The hazard may come from something mechanical or from electric shock. Read the warnings carefully.

When you see this Signal Word on the following pages, it will alert you to the possibility of damage to your garage door and/or the garage door opener if you do not comply with the cautionary statements that accompany it. Read them carefully.



WARNING

Mechanical



WARNING

Electrical



CAUTION

Introduction

Planning

Survey your garage area to see if any of the conditions below apply to your installation. Depending on your requirements, additional materials may be required.

THIS GARAGE DOOR OPENER IS COMPATIBLE WITH:

- Doors that use a torsion bar and springs. The torsion bar must be 1 inch (2.5 cm) diameter.
- 4-6 inch (10-15 cm) drums, not to be used on tapered drums over 6 inches (15 cm).
- High lift and standard lift sectional doors up to 14 feet (4.2 m) high.
- Doors up to 18 feet (5.4 m) wide.
- Doors up to 180 sq. ft. (16.7 sq. m).

NOTE: Inspect the torsion bar while the door is raised and lowered. It is important that there is no noticeable movement up and down or left and right. If the movement is not corrected, the life of the garage door opener will be greatly reduced.

Review or inspect proposed installation area. The garage door opener can be installed on the left or right side of door. Select the side that meets the requirements listed below.

a Must have minimum of 2-1/2 inches (6.4 cm) between the garage wall and the center of the torsion bar.

b Must have minimum of 3 inches (7.6 cm) between the ceiling and the center of torsion bar.

c Must have minimum of 8 inches (20.3 cm) between the side garage wall (or obstruction) and the end of torsion bar.

d The torsion bar must extend at least 1-5 inches (2.5-12 cm) past the bearing plate.

e An electric outlet is required within 6 feet (1.8 m) of the installation area. If outlet does not exist, contact a qualified electrician.

f Depending upon garage construction, extension brackets or wood blocks may be needed to install safety reversing sensors.

g Alternate floor mounting of the safety reversing sensors will require hardware not provided.

h Any gap between the floor and the bottom of the door must not exceed 1/4 inch (6 mm), otherwise the safety reversal system may not work properly.

i A model 475LM EverCharge® Standby Power System is strongly recommended if there is no access door to the garage, as this garage door opener cannot be used in conjunction with an external emergency release mechanism.

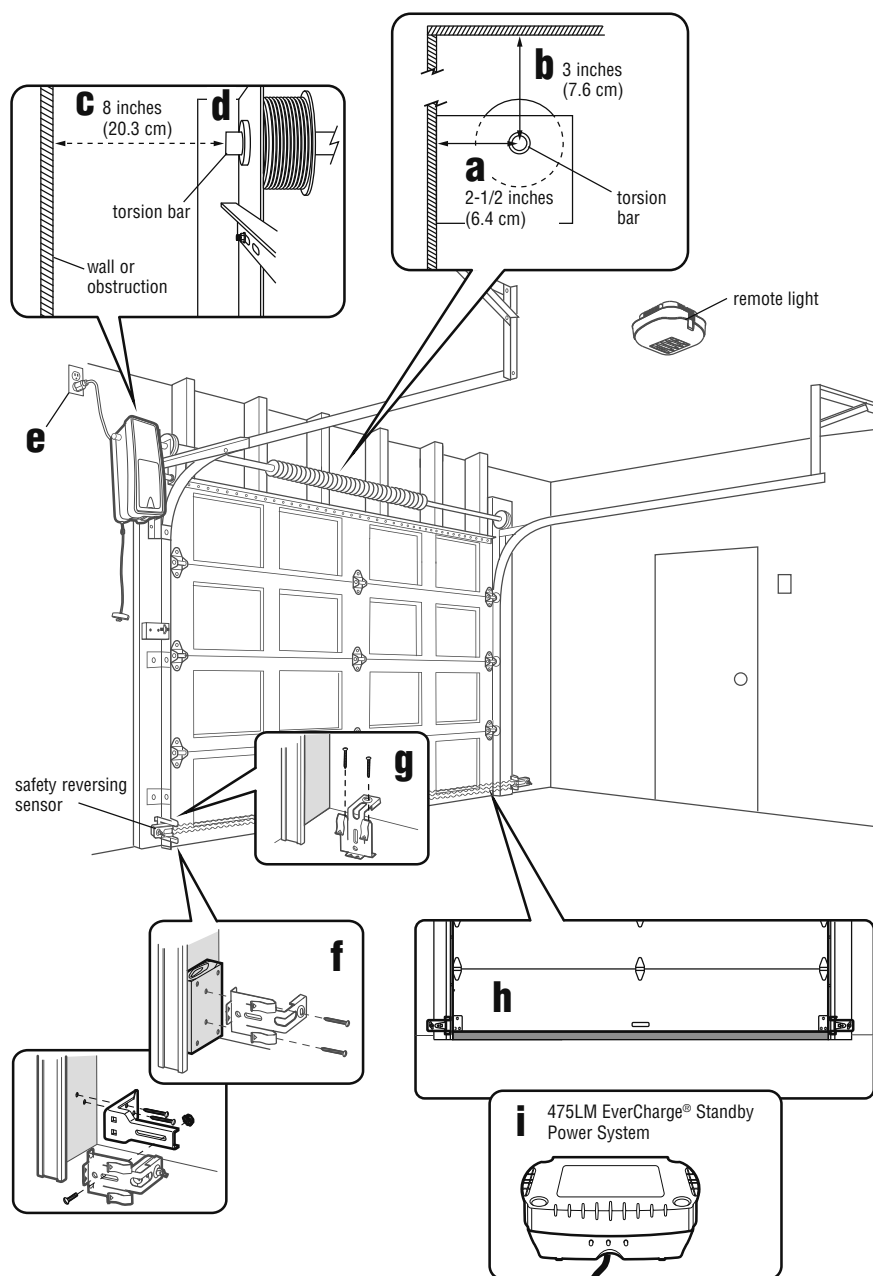

Introduction

Preparing Your Garage Door

BEFORE YOU BEGIN:

- Disable locks.
- Remove any ropes connected to the garage door.

Complete the following test to make sure the garage door is balanced and is not sticking or binding:

1. Lift the door halfway up. Release the door. If balanced, it should stay in place, supported entirely by its springs.
2. Raise and lower the door to check for binding or sticking.

If your door binds, sticks, or is out of balance, call a trained door systems technician.

3. Verify equal cable tension on each side of door. Cable tension should remain equal during the entire travel of the door.

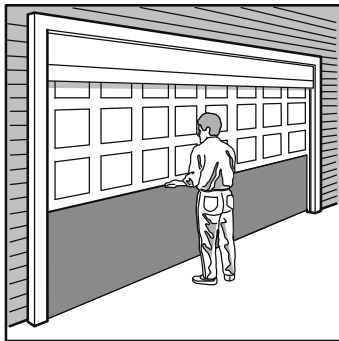

Sectional Door

⚠ WARNING

To prevent possible **SERIOUS INJURY** or **DEATH**:

- **ALWAYS** call a trained door systems technician if garage door binds, sticks, or is out of balance. An unbalanced garage door may **NOT** reverse when required.
- **NEVER** try to loosen, move or adjust garage door, door springs, cables, pulleys, brackets or their hardware, **ALL** of which are under **EXTREME** tension.
- Disable **ALL** locks and remove **ALL** ropes connected to garage door **BEFORE** installing and operating garage door opener to avoid entanglement.

CAUTION

To prevent damage to garage door and opener:

- **ALWAYS** disable locks **BEFORE** installing and operating the opener.
- **ONLY** operate garage door opener at 120 V, 60 Hz to avoid malfunction and damage.
- **DO NOT** exceed 10 complete cycles of door operation per hour.

Specifications

Volts	120 Vac - 60 Hz, ONLY
Current	1.0 AMP
Rated Load325 in. lb/sec 10 Cycles per Hour

Tools Needed

During assembly, installation and adjustment of the garage door opener, instructions will call for hand tools as illustrated below.

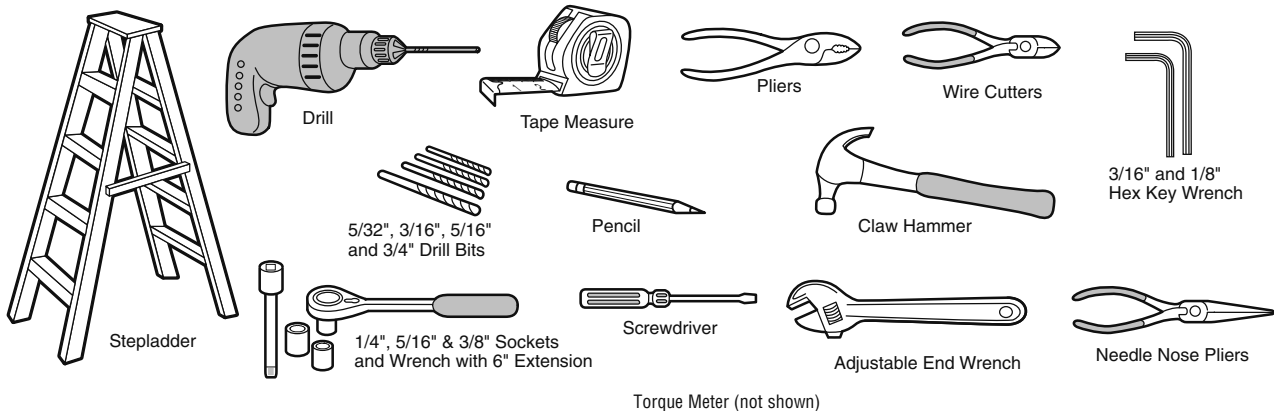

Introduction

Carton Inventory

Accessories included with the garage door opener will vary depending on the model purchased. If anything is missing, carefully check the packing material.

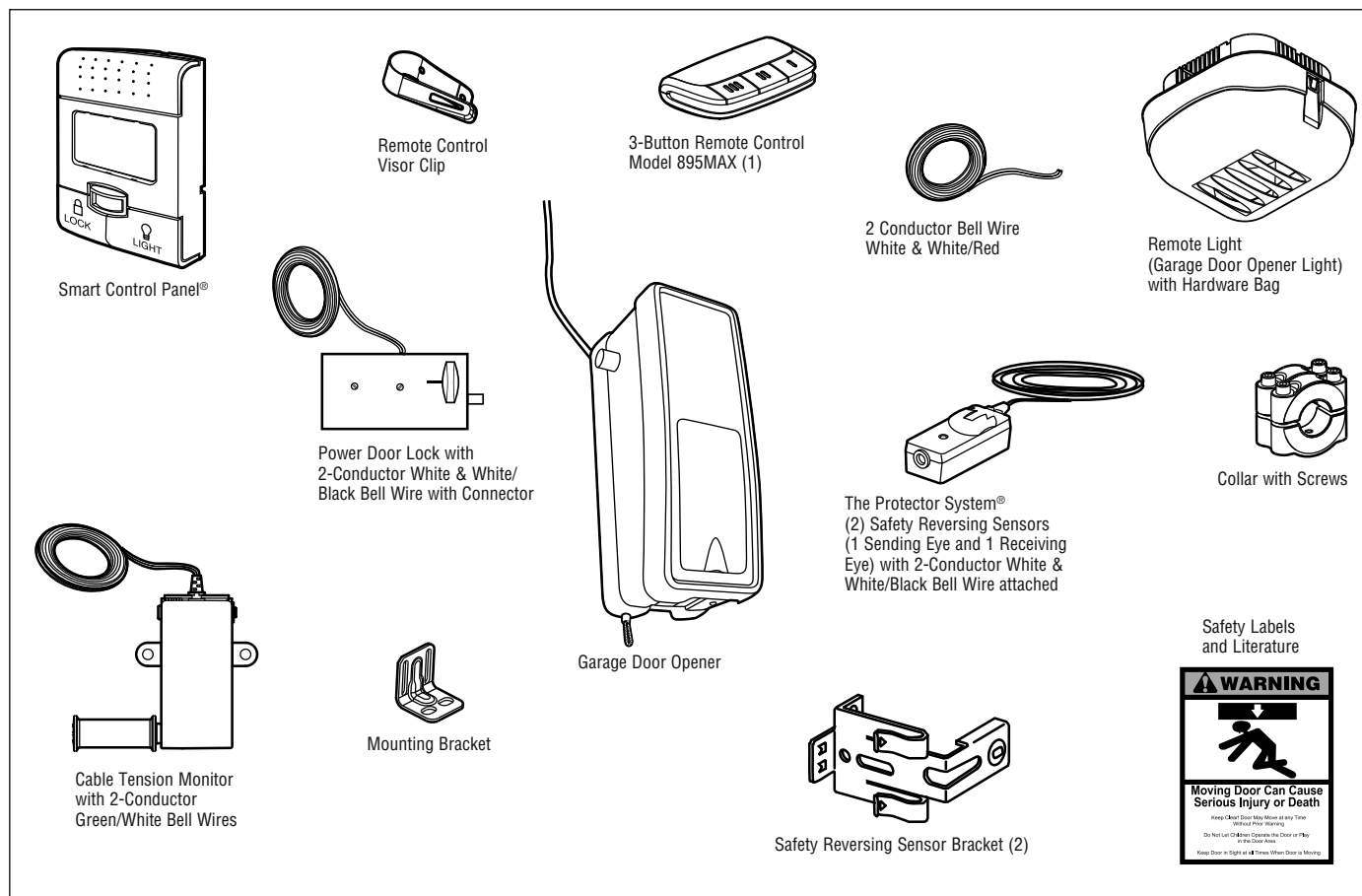

Hardware

Hex Screw #14-10x1-7/8" (4)

Screw #6x1-1/4" (2)

Machine Screw #6x1" (2)

Carriage Bolt 1/4"-20x1/2" (2)

Wing Nut 1/4"-20 (2)

Pan Head Screw 1/4"-20x1/2" (2)

Hex Head Screw #8x1" (2)

Self Tapping Screw #10-32 (2)

Drywall Anchor (2)

Drywall Anchor (Screw-In) (2)

Handle

Rope

Insulated Staples (30)

Lock Template

Assembly

1 Attach the Collar to the Garage Door Opener

To avoid installation difficulties, do not run the garage door garage door opener until instructed to do so.

The garage door opener can be installed on either side of the door (see PLANNING section page 3). The illustrations shown are for installation on the left side.

- 1 Loosen the collar screws.
- 2 Attach collar to the garage door opener motor shaft. The side of the collar with the larger hole should be placed on the motor shaft. Ensure that the collar is seated all the way on motor shaft until stop is reached.
- 3 Position the collar so the screws are facing out and are accessible when attached to the torsion bar.
- 4 Tighten the screws on both sides of the collar equally to secure collar to the motor shaft (to 12-14 ft./lbs. of torque).

NOTE: Do not tighten set screws until indicated.

WARNING

To prevent possible SERIOUS INJURY or DEATH, the collar MUST be properly tightened. The door may NOT reverse correctly or limits may be lost due to collar slip.

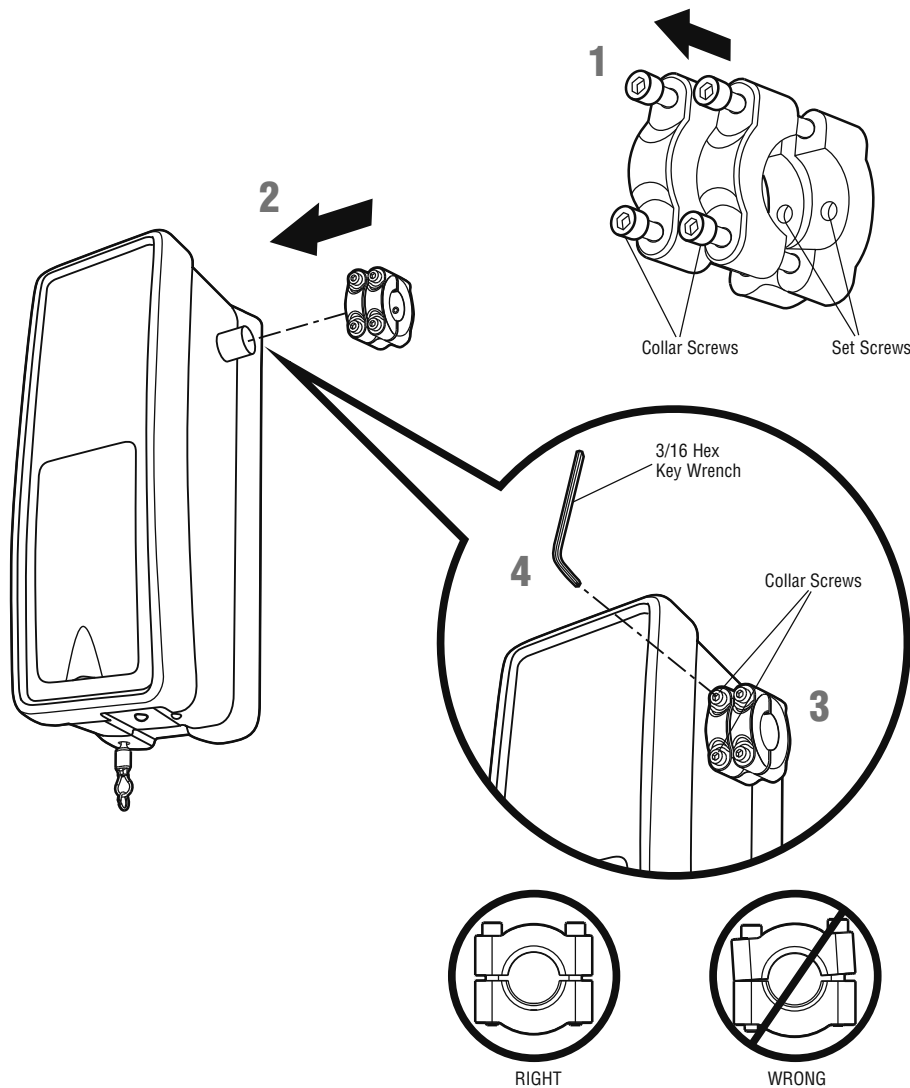

Assembly

2 Attach Mounting Bracket to Garage Door Opener

- 1 Loosely attach slotted side of mounting bracket to the same side of the garage door opener as the collar, using self-threading screws provided.

HARDWARE

Screw
#10-32

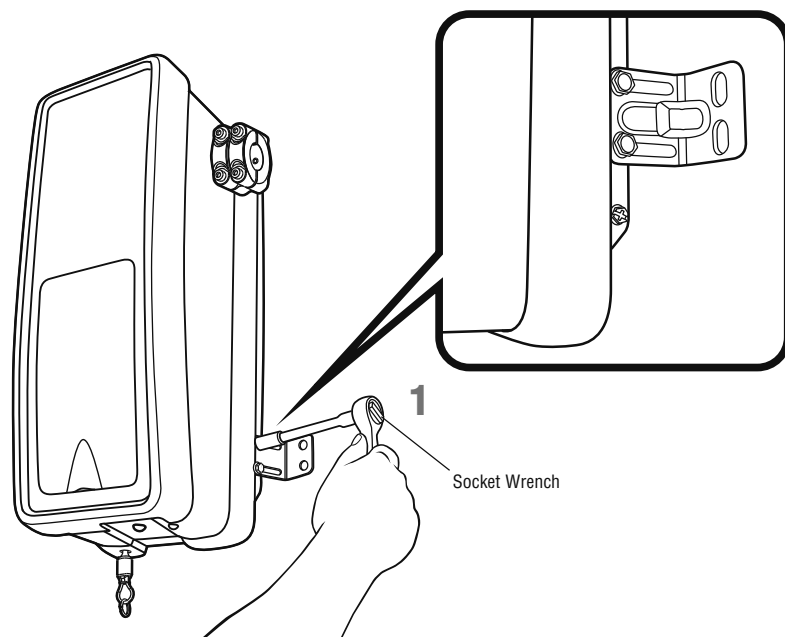

Installation

IMPORTANT INSTALLATION INSTRUCTIONS

WARNING

To reduce the risk of SEVERE INJURY or DEATH:

1. READ AND FOLLOW ALL INSTALLATION WARNINGS AND INSTRUCTIONS.
2. Install door operator ONLY on properly balanced and lubricated door. An improperly balanced door may NOT reverse when required and could result in SEVERE INJURY or DEATH.
3. ALL repairs to cables, spring assemblies and other hardware MUST be made by a trained door systems technician BEFORE installing garage door opener.
4. Disable ALL locks and remove ALL ropes connected to door BEFORE installing garage door opener to avoid entanglement.
5. Mount the emergency release within reach, but at least 6 feet (1.83 m) above the floor and avoiding contact with vehicles to avoid accidental release.
6. NEVER connect door operator to power source until instructed to do so.
7. NEVER wear watches, rings or loose clothing while installing or servicing the garage door opener. They could be caught in door or operator mechanisms.
8. Install wall-mounted door control:
 - within sight of the door.
 - out of reach of children at minimum height of 5 feet (1.5 m).
 - away from ALL moving parts of the door.
9. Install the Entrapment Warning Placard next to the door control in a prominent location.
10. Place manual release/safety reverse test label in plain view on inside of door.
11. Upon completion of installation, test safety reversal system.

Installation

1 Position and Mount the Garage Door Opener

NOTE: For additional mounting options refer to the accessories page.

- 1 Close the garage door completely.
- 2 Slide the garage door opener onto the end of the torsion bar. If the torsion bar is too long or damaged, you may need to cut the torsion bar. Ensure the collar does not touch the bearing plate.
- 3 Use a level to position and vertically align the garage door opener. Verify the mounting bracket is located on a solid surface such as wood, concrete or door/flag bracket.
- 4 When the garage door opener is properly aligned, mark the mounting bracket holes. If necessary, tighten collar screws on the torsion bar to hold garage door opener in place while marking holes.

NOTE: The garage door opener does not have to be flush to wall.

- 5 Remove the garage door opener from torsion bar. Drill 3/16 inch pilot holes at the marked locations. Drill through steel plate if necessary.
- 6 Slide the garage door opener back onto the torsion bar until pilot holes align with bracket. Securely tighten collar screws to the torsion bar to 12-14 ft./lbs. of torque.
- 7 Securely tighten both set screws.

NOTE: You may need to manually raise the door slightly in order to reach the set screws.

- 8 Secure the mounting bracket to the wall and to the garage door opener. Use the 14-10x1-7/8 inch screws to secure the mounting bracket to the wall.
- 9 Secure the antenna wire with a staple to prevent antenna from being entangled in a door roller.

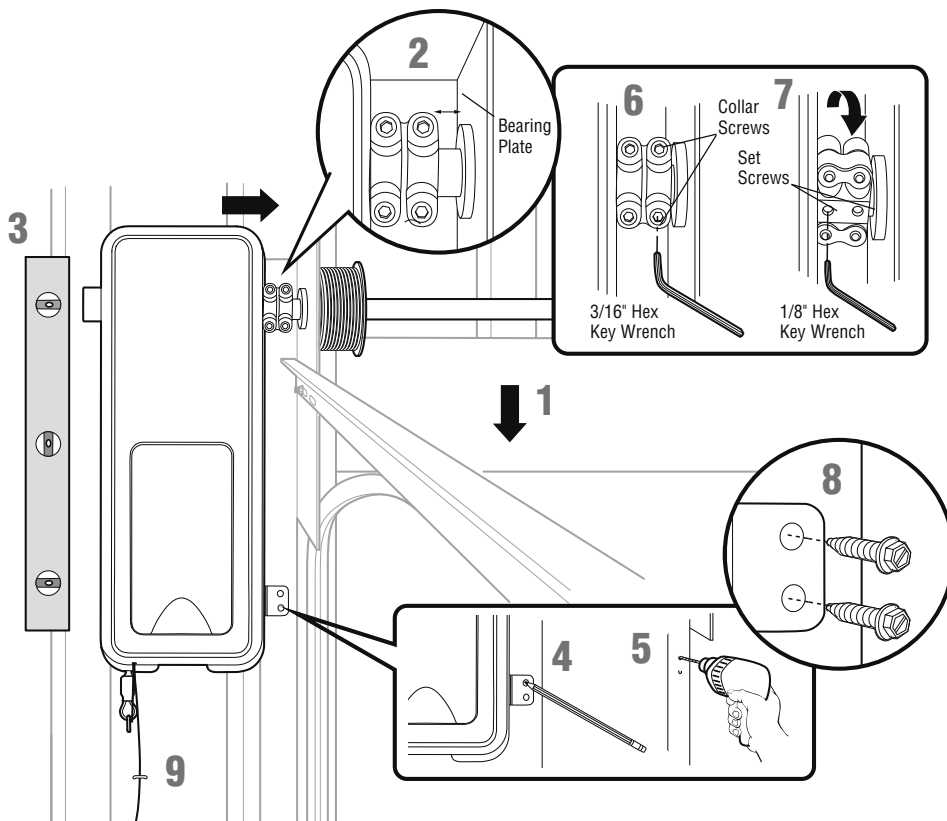

⚠ WARNING

To prevent possible **SERIOUS INJURY** or **DEATH**:

- Concrete anchors **MUST** be used if mounting bracket into masonry.
- **NEVER** try to loosen, move or adjust garage door, springs, cables, pulleys, brackets or their hardware, **ALL** of which are under **EXTREME** tension.
- **ALWAYS** call a trained door systems technician if garage door binds, sticks or is out of balance. An unbalanced garage door might **NOT** reverse when required.
- Operator **MUST** be mounted at a right angle to the torsion bar to avoid premature wear on the collar.

HARDWARE

Staple



14-10x1-7/8" Hex Screw

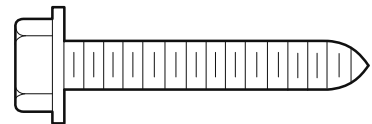

Installation

2 Attach the Emergency Release Rope and Handle

- 1 Thread one end of the rope through the hole in the top of the red handle so "NOTICE" reads right side up as shown. Secure with an overhand knot at least 1 inch (2.5 cm) from the end of the rope to prevent slipping.
- 2 Thread the other end of the rope through the loop in the emergency release cable. Adjust rope length so the handle is no higher than 6 feet (1.83 m) above the floor. Secure with an overhand knot.

NOTE: If it is necessary to cut the rope, heat seal the cut end with a match or lighter to prevent unraveling.

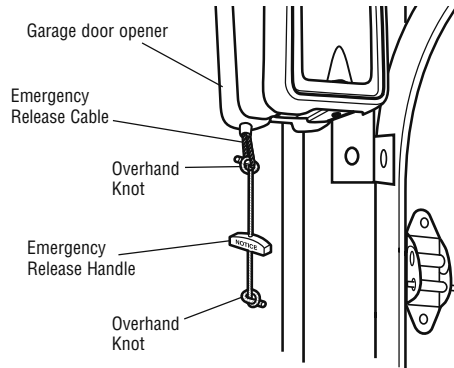

⚠ WARNING

To prevent possible **SERIOUS INJURY** or **DEATH** from a falling garage door:

- If possible, use emergency release handle to disengage door **ONLY** when garage door is **CLOSED**. Weak or broken springs or unbalanced door could result in an open door falling rapidly and/or unexpectedly.
- **NEVER** use emergency release handle unless garage doorway is clear of persons and obstructions.

HARDWARE

Handle

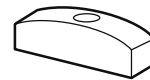

Rope



3 Install Power Door Lock

The power door lock is used to prevent the garage door from being manually opened once the door is fully closed.

- 1 The power door lock must be mounted within 10 feet of garage door opener with approximately a 3 inch (7.6 cm) distance between the center of a door roller and the hole for the power door lock bolt. If possible, mount on same side as garage door opener. The second roller from the bottom is ideal for most installations.
- 2 Ensure rail surface is clean and attach lock template to track.
- 3 Drill holes as marked on the template.
- 4 Fasten power door lock to the outside of the garage door track with hardware provided.
- 5 Run bell wire up wall to garage door opener. Use insulated staples to secure wire in several places. Insert wire through the bottom of the garage door opener.
- 6 Plug the connector into the garage door opener.

HARDWARE

Lock Screw
1/4"-20x1/2"

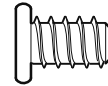

Staples

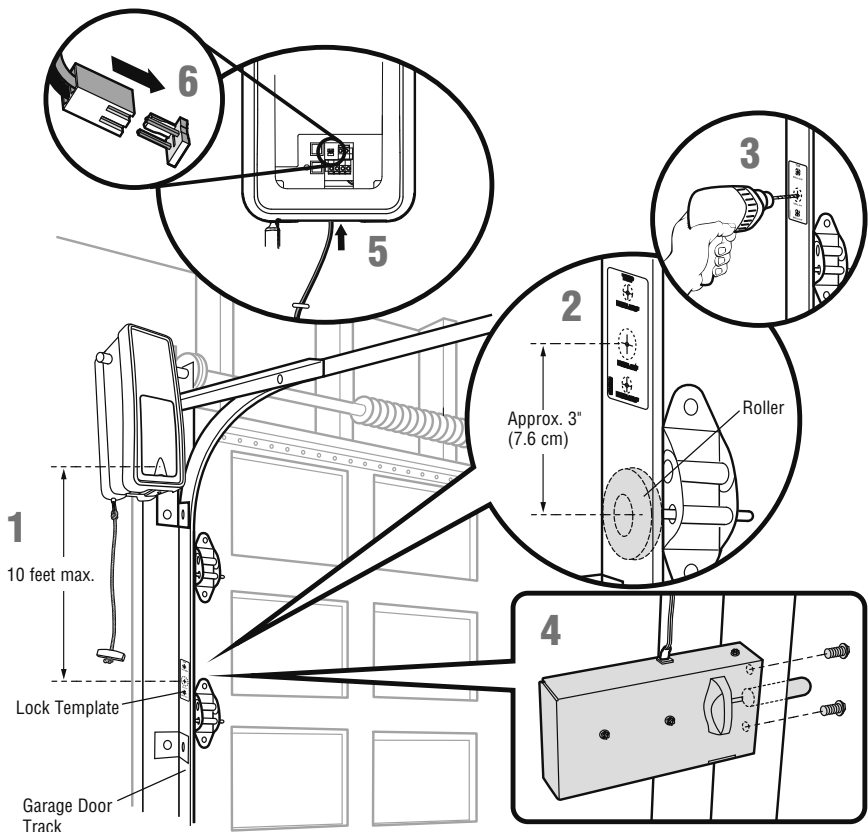

Installation

4 Attach the Cable Tension Monitor (Required)

NOTE: The cable tension monitor is shipped for left side installation. It is recommended that the cable tension monitor be installed on the same side of the door as the garage door opener. For right side installation, remove the snap-ring holding the roller in place and reassemble it on the opposite side of the cable tension monitor.

- 1 Position the cable tension monitor as close to the drum as possible. Make sure cable tension monitor is located over a wood support member and the roller is free from any obstructions.

NOTE: There must be no obstructions in the installation area that prevent the cable tension monitor or the cable itself from closing completely when slack is detected.

- 2 Mark and drill 3/16 inch pilot holes for screws (pilot holes are not required for anchors).

NOTE: If the cable tension monitor cannot be mounted into wood with the lag screws provided, it can be mounted into 1/2 inch or greater drywall using the wall anchors (2) and the #8 hex screws (2) provided in the hardware bag.

- 3 Attach the cable tension monitor to the wall using the hardware provided. Make sure that the roller is on top of the cable.

- 4 Run bell wire to garage door opener. Use insulated staples to secure wire.

- 5 Connect bell wire to the green quick-connect terminals on the garage door opener (polarity is not important).

NOTE: Cable must have tension through entire door travel. Make sure there is no slack in cable on opposite side of garage door during normal operation. If slack occurs during door travel, adjust cables as required.

The cable tension monitor MUST be connected and properly installed before the garage door opener will move in the down direction.

The cable tension monitor detects ANY slack that may occur in the cables and will reverse the door, eliminating service calls.

HARDWARE



#8 Hex Head Screw (2)



Screw #6 (2)



Staples

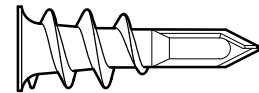

Wall Anchor (2)

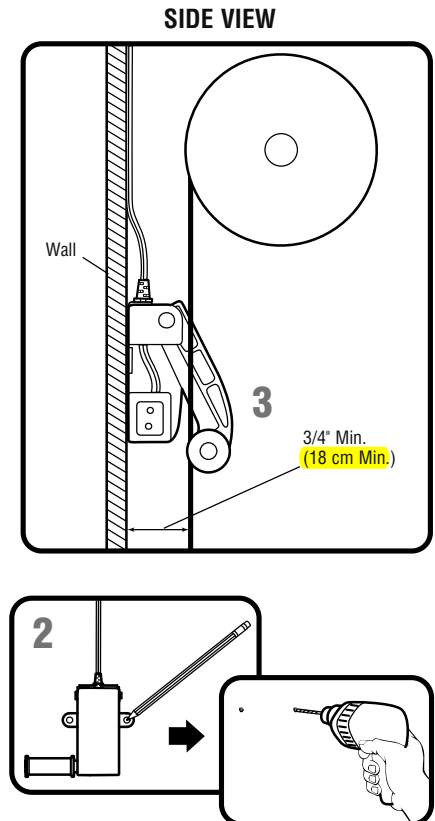
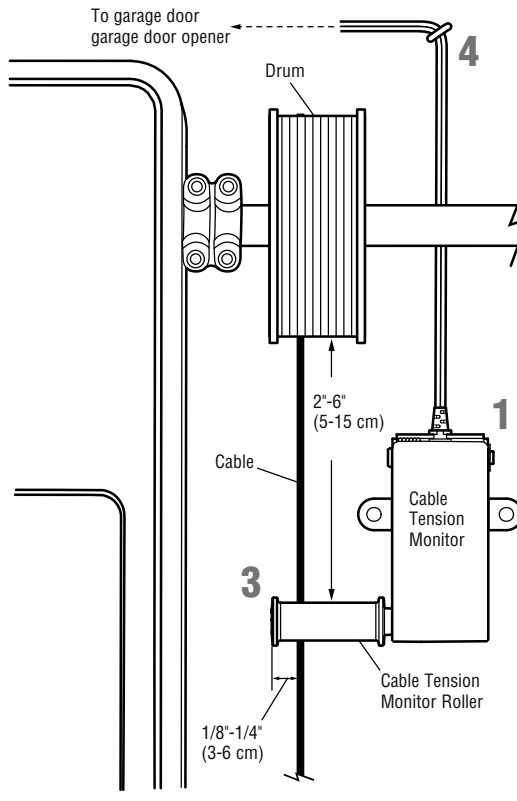
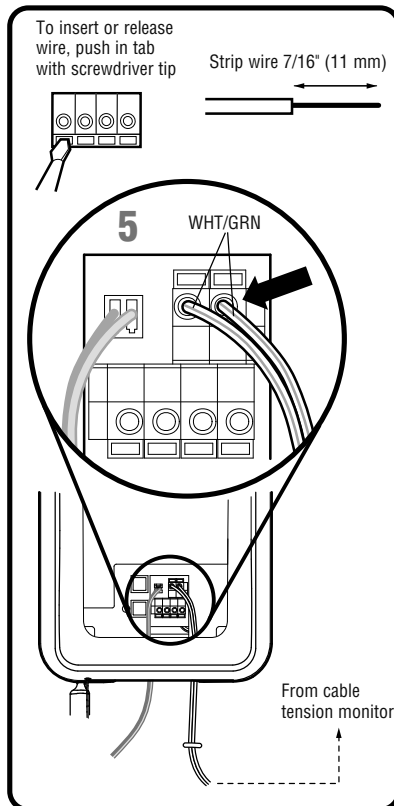

Installation

5 Install the Smart Control Panel®

Locate door control within sight of door, at a minimum height of 5 feet (1.5 m) where small children cannot reach, away from moving parts of door and door hardware.

If installing into drywall, drill 5/32 inch holes and use the anchors provided. For pre-wired installations (as in new home construction), control panel may be mounted to a single gang box.

NOTE: The functional temperature range of the door control is between -4° F (-20° C) and 122° F (50° C). Scroll speed of display is slower at lower temperatures although the door control remains fully functional.

CAUTION: Continuous exposure of the door control to temperatures below -22° F (-30° C) may damage the LCD screen.

SPECIAL NOTE: Only one Smart Control Panel® can be connected to each garage door opener. If additional door controls are desired to operate the same garage door opener, it is recommended to use model 378LM wireless door control as the secondary door control.

- 1** Strip 7/16 inch (11 mm) of insulation from one end of bell wire and connect to the two screw terminals on back of door control: white wire to W(2) and white/red wire to R(1).
- 2a** Remove push bar cover by gently prying at the lower/middle portion of the cover with a small flat-head screwdriver. Fasten with 6AB x 1-1/4" self-tapping screws (drywall installation) or 6-32 x 1" machine screws (into gang box) as follows:
 - b** Install bottom screw, allowing 1/8 inch (3 mm) to protrude above wall surface.
 - c** Position bottom of door control on screw head and slide down to secure. Adjust screw for snug fit.
 - d** Install top screw with care to avoid cracking plastic housing. **DO NOT overtighten.**
 - e** Replace cover by inserting top tabs first and then snap cover in place.
- 3 (For standard installations ONLY)** Run bell wire up wall and across ceiling to the garage door opener. Use insulated staples to secure wire in several places. **DO NOT** pierce wire with a staple, creating a short or open circuit.
- 4** Strip 7/16 inch (11 mm) of insulation from end of bell wire. Connect bell wire to the quick-connect terminals on the garage door opener: white to white and white/red to red.
- 5** Fasten the warning placard to the wall next to the door control.

NOTE: If you have any trouble with the operation of the buttons, loosen the top mounting screw. **DO NOT** connect the power and operate the garage door opener at this time. The door will travel to the full open position but will not return to the close position until the sensor beams are connected and properly aligned. See page 15.

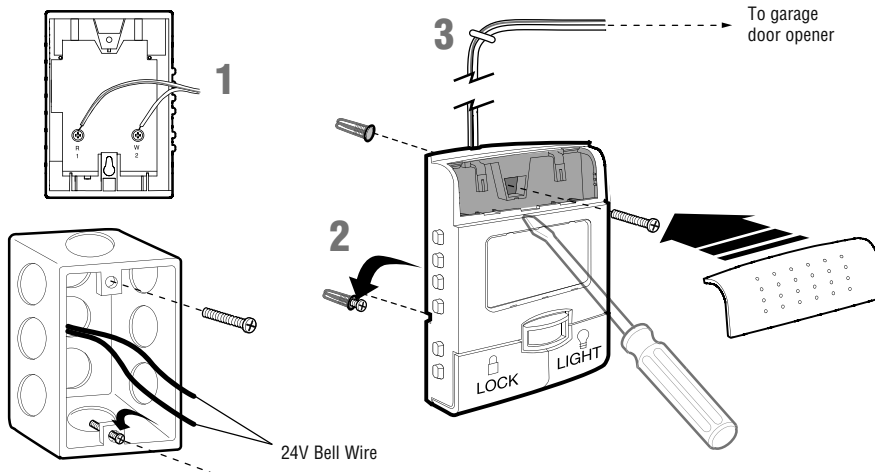

⚠️ WARNING

To prevent possible SERIOUS INJURY or DEATH from electrocution:

- Be sure power is NOT connected BEFORE installing door control.
- Connect ONLY to 24 VOLT low voltage wires.

To prevent possible SERIOUS INJURY or DEATH from a closing garage door:

- Install door control within sight of garage door, out of reach of children at a minimum height of 5 feet (1.5 m) and away from ALL moving parts of door.
- NEVER permit children to operate or play with door control push buttons or remote controls.
- Activate door ONLY when it can be seen clearly, is properly adjusted and there are no obstructions to door travel.
- ALWAYS keep garage door in sight until completely closed. NEVER permit anyone to cross path of closing garage door.

HARDWARE

Screw 6ABx1-1/4"
(standard installation)

Insulated Staples

Screw 6-32x1" (pre-wired)

Drywall Anchors

4

To insert or release wire, push in tab with screwdriver tip

WHT
Red White
WHT/RED

5
(Fasten next to door control)

Installation

IMPORTANT INSTALLATION INSTRUCTIONS

⚠️ ⚠️ WARNING

To reduce the risk of SEVERE INJURY or DEATH:

1. This portable luminaire has a polarized plug (one blade is wider than the other) as a feature to reduce the risk of electric shock.
2. This plug will fit in a polarized outlet ONLY one way.
3. If the plug does not fit fully in the outlet, reverse the plug.
4. If it still does not fit, contact a qualified electrician.
5. NEVER use with an extension cord unless plug can be fully inserted.
6. DO NOT alter the plug.
7. Light is intended for ceiling mount and indoor applications ONLY.

6 Install Remote Light

The remote light (garage door opener light) is designed to plug directly into a standard 120V outlet. Select an appropriate location on the ceiling to mount the light within 6 feet (1.8 m) of an electrical outlet so that the cord and light are away from moving parts.

1. Install the hinge and latch clips. Clips slide in between the metal plate and the plastic housing on each side of the light base.
2. Install screws into the ceiling leaving 1/8 inch (3.1 mm) of the thread exposed.
NOTE: If installing light on drywall and a ceiling joist cannot be located, use wall anchors provided. No pilot hole is required for wall anchors.
3. Determine the length of power cord needed to reach the nearest outlet. Wind any excess cord around cord retainer on the top side of the light base.
4. Install the light base by pushing onto the screws and turning the base clockwise to lock the light in place.
5. Install two Type A19 incandescent or compact fluorescent bulbs. 100 watt maximum per bulb, 200 watts total.
6. Install the light lens by hooking one end of the lens over the hinge and pressing up on the other end to latch into place.
7. Plug in the light to outlet.

NOTE: Light will not operate until the garage door opener is activated.

HARDWARE

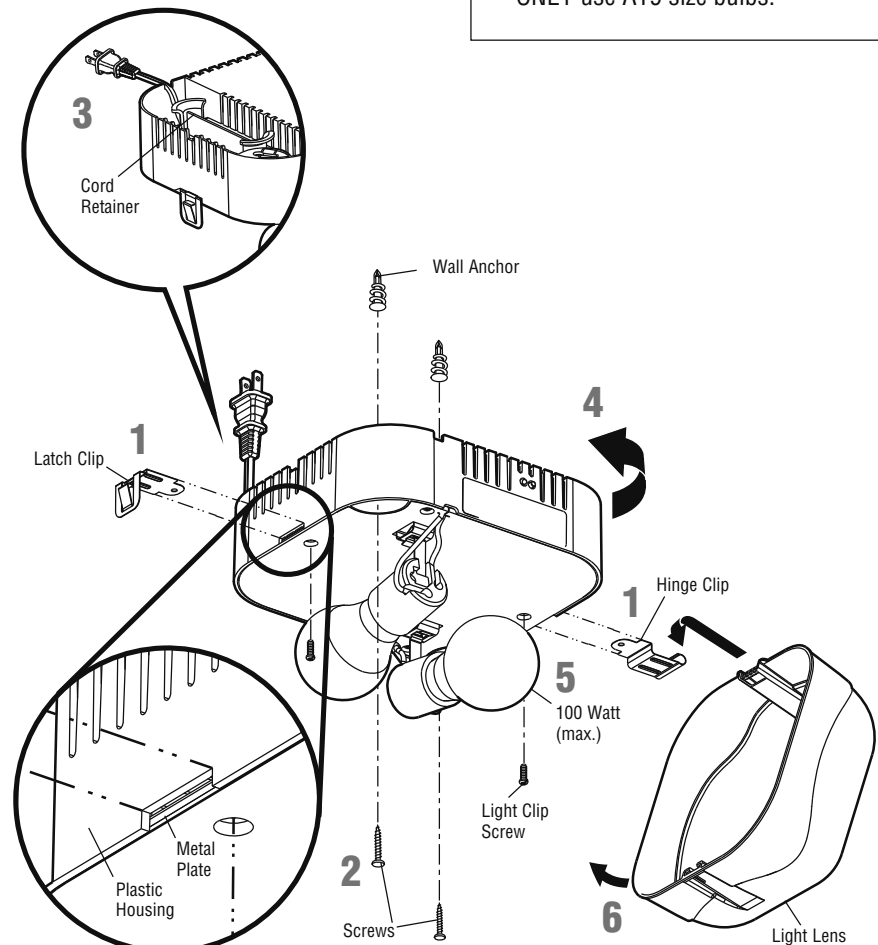
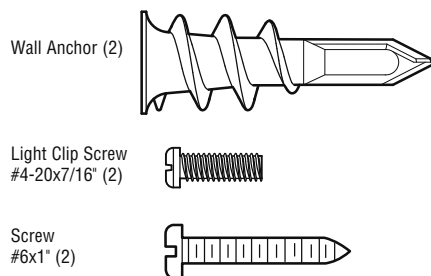

CAUTION

To prevent possible OVERHEATING of the endpanel or light socket:

- DO NOT use short neck or specialty light bulbs.
- DO NOT use halogen bulbs. Use ONLY incandescent.

To prevent damage to the opener:

- DO NOT use bulbs larger than 100W.
- ONLY use A19 size bulbs.

Installation

7 Electrical Requirements

To avoid installation difficulties, do not run the garage door opener at this time.

To reduce the risk of electric shock, your garage door opener has a grounding type plug with a third grounding pin. This plug will only fit into a grounding type outlet. If the plug doesn't fit into the outlet you have, contact a qualified electrician to install the proper outlet.

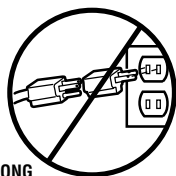
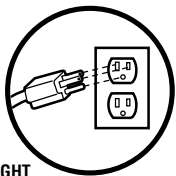

PERMANENT WIRING CONNECTION

If permanent wiring is required by your local code, refer to the following procedure.

To make a permanent connection through the 7/8 inch hole in the back of the garage door opener (according to local code):

1. Remove the garage door opener from the torsion bar, remove cover screws and set the cover aside.
2. Remove the attached green ground terminal.
3. Cut black and white wires and strip away 1/2 inch (1.3 cm) of insulation, 3 inch (7.6 cm) before spade terminals.
4. Remove the power cord from the garage door opener.
5. Install a 90° conduit or flex cable adapter to the 7/8 inch hole. Reinstall garage door opener to torsion bar.
6. Run wires through conduit, cut to proper length and strip insulation.
7. Attach with wire nuts provided.
8. Properly secure wire under plastic ties so that wire does not come in contact with moving parts.
9. Reinstall the cover.

To avoid installation difficulties, do not run the garage door opener at this time.

WARNING

To prevent possible **SERIOUS INJURY** or **DEATH** from electrocution or fire:

- Be sure power is **NOT** connected to the opener, and disconnect power to circuit **BEFORE** removing cover to establish permanent wiring connection.
- Garage door installation and wiring **MUST** be in compliance with **ALL** local electrical and building codes.
- **NEVER** use an extension cord, 2-wire adapter or change plug in **ANY** way to make it fit outlet. Be sure the opener is grounded.

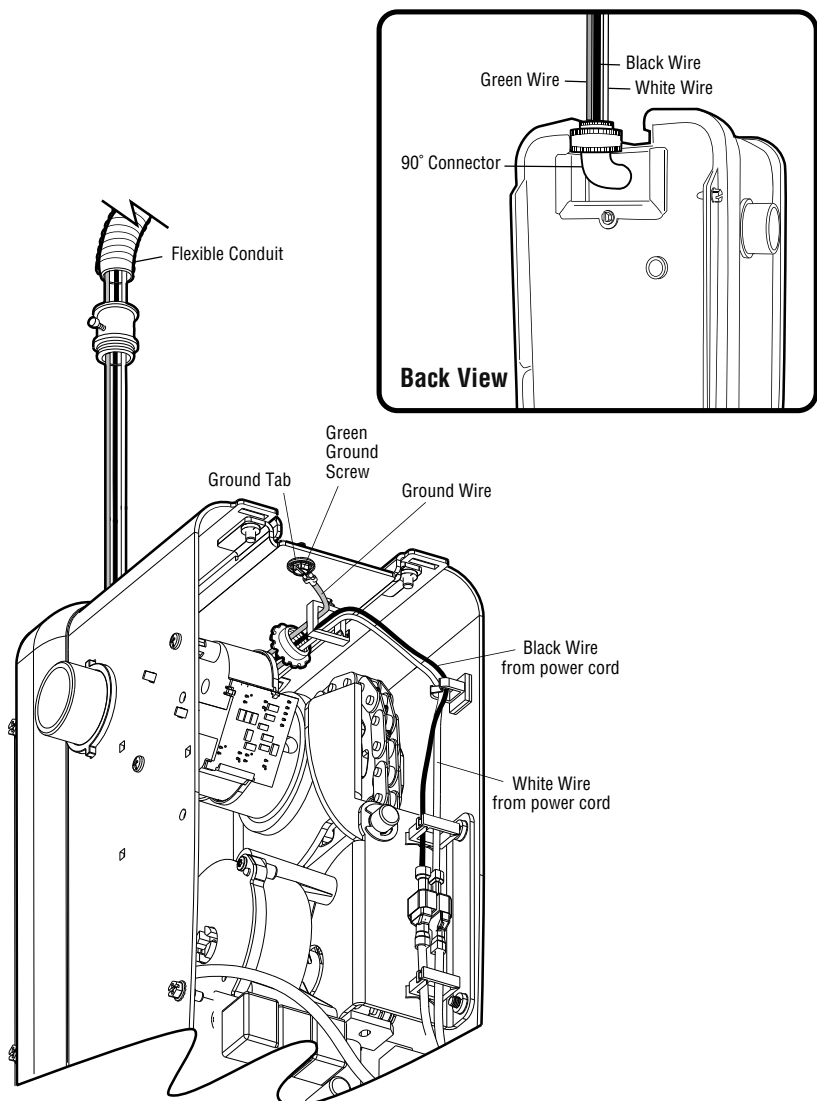

Installation

8 Install the EverCharge® Standby Power System (SPS) (optional)

If the optional EverCharge® Standby Power System is part of this installation it should be installed at this time. The SPS can be mounted to either the ceiling or a wall within 3 feet (.9 m) of the garage door opener.

1. Position the SPS on a structural support (ceiling joist or wall stud).
2. Attach the SPS to the support with the 1-1/2 inch lag screws (2) provided. There are mounting holes on either side of the SPS.
3. Connect the SPS cord into the connector on the bottom of the garage door opener.
4. Follow all instructions included with the EverCharge® Standby Power System to test for proper operation.

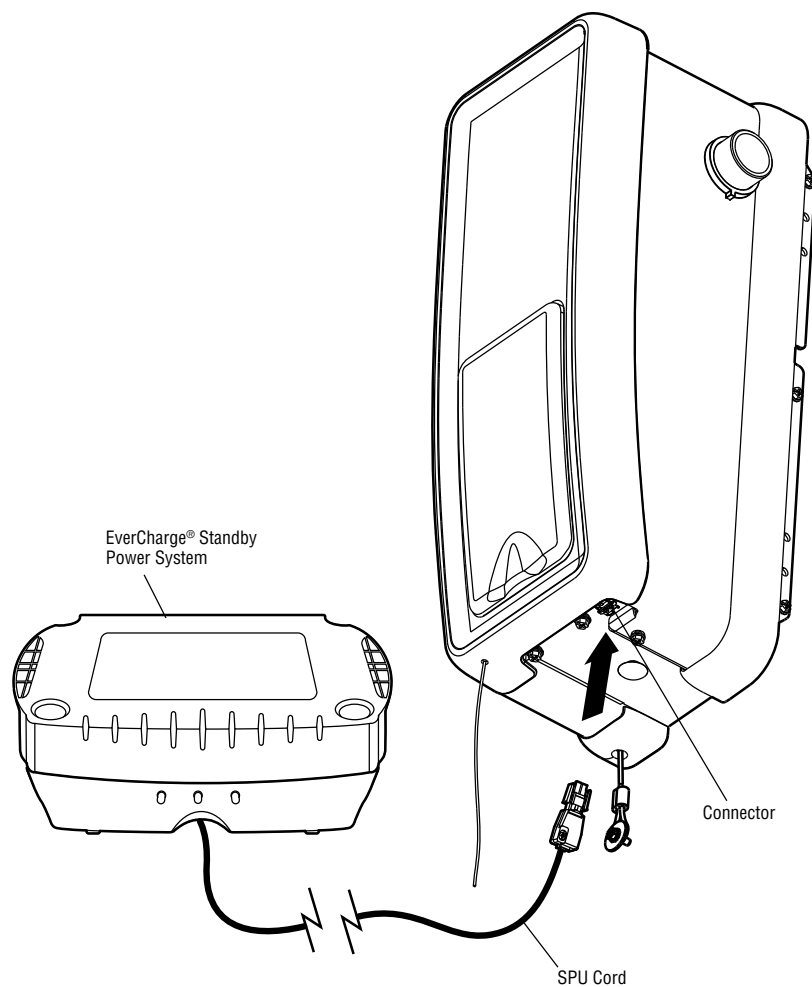

Installation

9 Install the Protector System®

The safety reversing sensor must be connected and aligned correctly before the garage door opener will move in the down direction. This is a required safety device and cannot be disabled.

IMPORTANT INFORMATION ABOUT THE SAFETY REVERSING SENSOR

When properly connected and aligned, the safety reversing sensor will detect an obstacle in the path of its electronic beam. The sending eye (with an amber indicator light) transmits an invisible light beam to the receiving eye (with a green indicator light). If an obstruction breaks the light beam while the door is closing, the door will stop and reverse to full open position, and the opener lights will flash 10 times.

The units must be installed inside the garage so that the sending and receiving eyes face each other across the door, no more than 6 inches (15 cm) above the floor. Either can be installed on the left or right of the door as long as the sun never shines directly into the receiving eye lens.

The mounting brackets are designed to clip onto the track of sectional garage doors without additional hardware.

If it is necessary to mount the units on the wall, the brackets must be securely fastened to a solid surface such as the wall framing. Extension brackets (see accessories) are available if needed. If installing in masonry construction, add a piece of wood at each location to avoid drilling extra holes in masonry if repositioning is necessary.

The invisible light beam path must be unobstructed. No part of the garage door (door tracks, springs, hinges, rollers or other hardware) may interrupt the beam while the door is closing.

⚠ WARNING

Be sure power is NOT connected to the garage door opener BEFORE installing the safety reversing sensor.

To prevent SERIOUS INJURY or DEATH from a closing garage door:

- Correctly connect and align the safety reversing sensor. This required safety device MUST NOT be disabled.
- Install the safety reversing sensor so beam is NO HIGHER than 6" (15 cm) above garage floor.

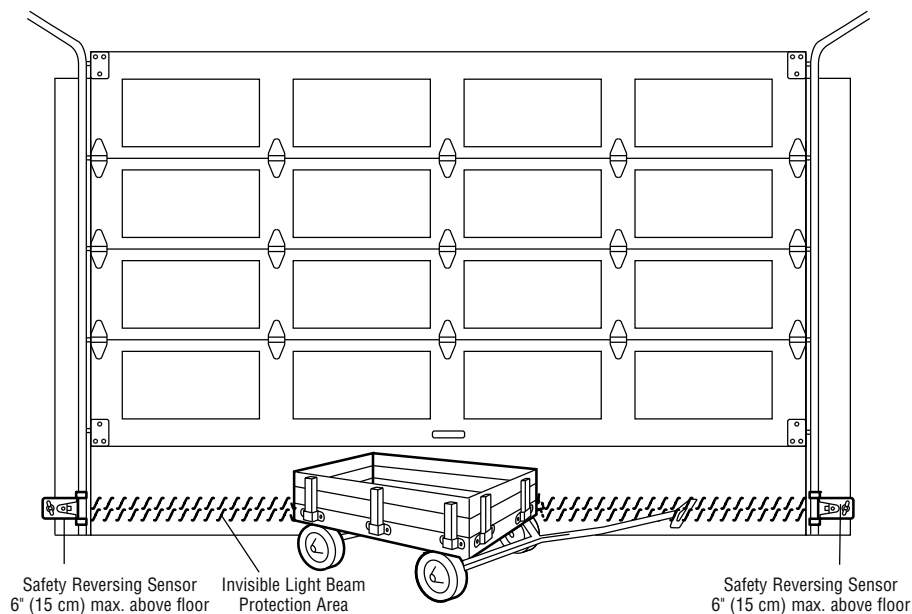

Facing the door from inside the garage.

Installation

INSTALLING THE BRACKETS

Be sure power to the opener is disconnected. Install and align the brackets so the safety reversing sensors will face each other across the garage door, with the beam no higher than 6" (15 cm) above the floor. They may be installed in one of three ways, as follows.

1a Track Installation

1. Slip the curved arms over the rounded edge of each door track, with the curved arms facing the door. Snap into place against the side of the track. It should lie flush, with the lip hugging the back edge of the track, as shown.

If your door track will not support the bracket securely, wall installation is recommended.

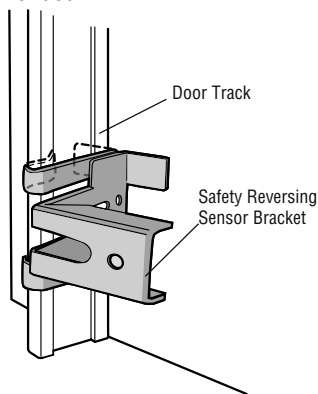

1b Wall Installation

1. Place the bracket against the wall with curved arms facing the door. Be sure there is enough clearance for the sensor beam to be unobstructed.
2. If additional depth is needed, an extension bracket (see Accessories) or wood blocks can be used.
3. Use bracket mounting holes as a template to locate and drill (2) 3/16" diameter pilot holes on the wall at each side of the door, no higher than 6" (15 cm) above the floor.
4. Attach brackets to wall with lag screws (not provided).

If using extension brackets or wood blocks, adjust right and left assemblies to the same distance out from the mounting surface. Make sure all door hardware obstructions are cleared.

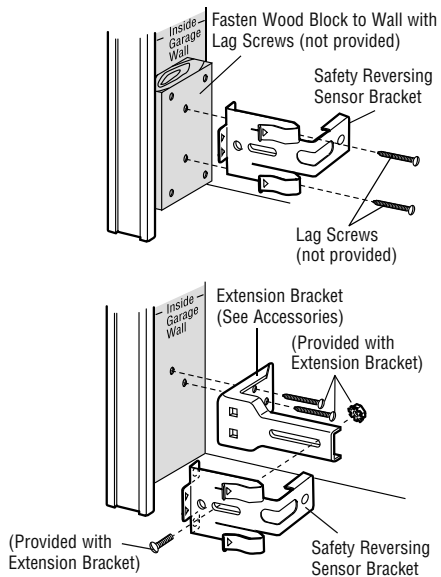

1c Floor Installation

1. Use wood blocks or extension brackets (see Accessories) to elevate sensor brackets so the lenses will be no higher than 6" (15 cm) above the floor.
2. Carefully measure and place right and left assemblies at the same distance out from the wall. Be sure all door hardware obstructions are cleared.
3. Fasten to the floor with concrete anchors as shown.

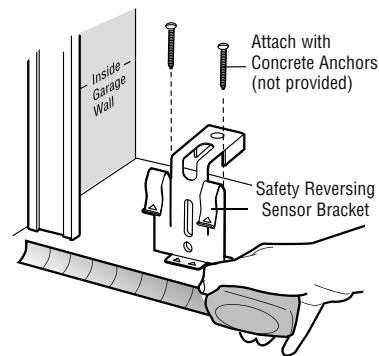

Installation

MOUNTING AND WIRING THE SAFETY REVERSING SENSORS

- 1 Slide a 1/4"-20x1/2" carriage bolt head into the slot on each sensor.
- 2 Use wing nuts to fasten safety reversing sensors to brackets, with lenses pointing toward each other across the door. Be sure the lens is not obstructed by a bracket extension.
- 3 Finger tighten the wing nuts.

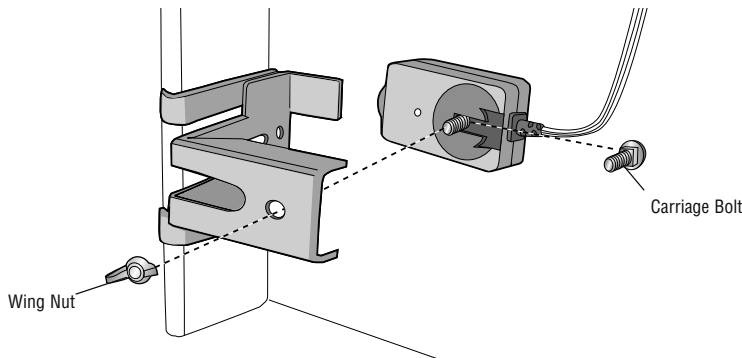

HARDWARE

Carriage Bolt
1/4"-20x1/2"

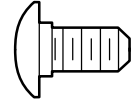

Wing Nut
1/4"-20



- 4 Run the wires from both safety reversing sensors to the opener. Use insulated staples to secure wire to wall and ceiling.
- 5 Strip 7/16" (11 mm) of insulation from each set of wires. Separate white and white/black wires sufficiently to connect to the opener quick-connect terminals: white to white and white/black to grey.

HARDWARE

Staple

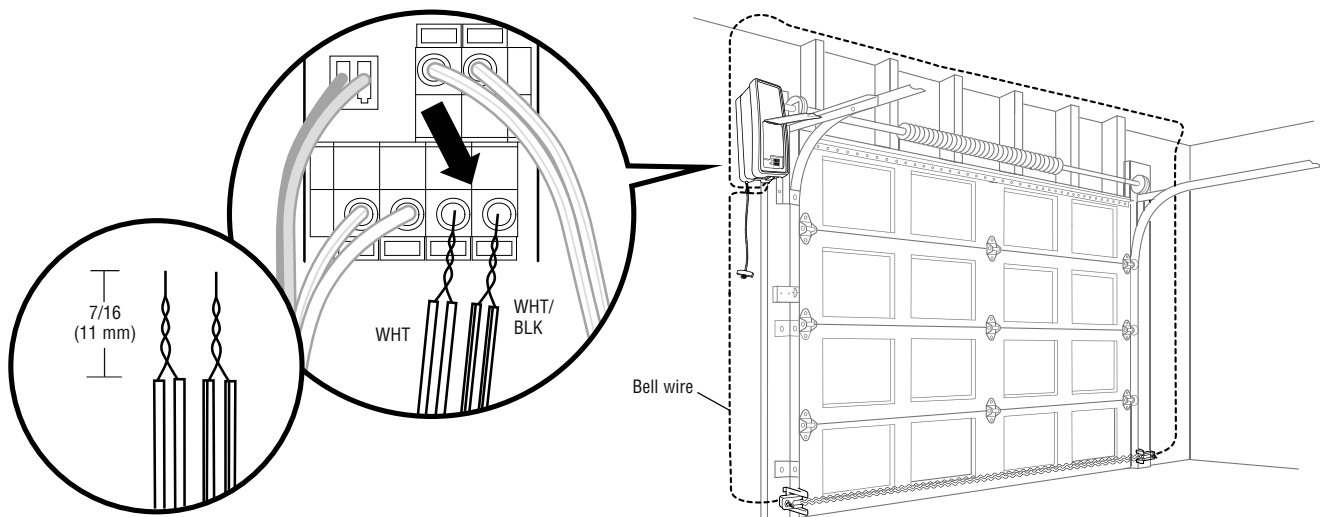

Installation

ALIGNING THE SAFETY REVERSING SENSORS

- 1 Plug in the opener. The indicator lights in both the sending and receiving eyes will *glow steadily* if wiring connections and alignment are correct.
The *sending eye* amber indicator light will glow regardless of alignment or obstruction. If the green indicator light in the *receiving eye* is off, dim, or flickering (and the invisible light beam path is not obstructed), alignment is required.
- 2 Loosen the *sending eye* wing nut and readjust, aiming directly at the *receiving eye*. Lock in place.
- 3 Loosen the *receiving eye* wing nut and adjust the safety reversing sensor until it receives the sender's beam. When the green indicator light *glows steadily*, tighten the wing nut.

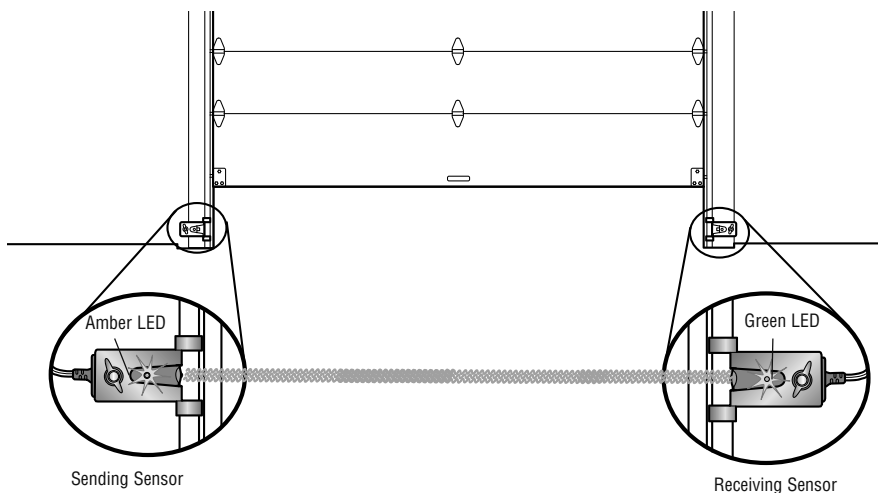

TROUBLESHOOTING THE SAFETY REVERSING SENSORS

- 1 If the *sending eye* indicator light does not *glow steadily* after installation, check for:
 - Electric power to the opener.
 - A short in the white or white/black wires. These can occur at staples, or at opener connections.
 - Incorrect wiring between safety reversing sensors and opener.
 - A broken wire.
- 2 If the *sending eye* indicator light *glows steadily* but the *receiving eye* indicator light doesn't:
 - Check alignment.
 - Check for an open wire to the receiving eye.
- 3 If the receiving eye indicator light is dim, realign either sensor.

NOTE: When the invisible beam path is obstructed or misaligned while the door is closing, the door will reverse. If the door is already open, it will not close. The remote lights will blink 10 times. (If bulbs are not installed, 10 clicks can be heard.) See page 15.

Adjustment

1 Program the Travel Limits

Travel limits regulate the points at which the door will stop when moving up or down.

Adjust the position of the door by using the black and purple buttons. Black moves the door UP (open) and purple moves the door DOWN (close).

SETTING THE UP POSITION:

- 1 Press and hold the black button until the LED starts flashing slowly, then release.
- 2 Push and hold the black button until the door reaches the desired UP (open) position.

NOTE: Make sure the door opens high enough for your vehicle.

- 3 Push the door control or programmed remote control. This sets the UP (open) limit and begins closing the door.
- 4 Immediately when the door begins to close, press and release either the black or purple button. This will stop the door.

SETTING THE DOWN POSITION:

- 5 Push and hold the purple button until the door reaches the desired DOWN (closed) position.
- 6 Once the door is closed, if there appears to be too much pressure on the door, you may toggle the door back and forth using the black and purple buttons to reach the desired closed position.
- 7 Push the door control or programmed remote control. This sets the DOWN (close) limit and the door should open.

Proceed to *Set the Force*.

WARNING

Without a properly installed safety reversal system, persons (particularly small children) could be **SERIOUSLY INJURED** or **KILLED** by a closing garage door.

- NEVER learn forces or limits when door is binding or sticking. Repair door first.
- Incorrect adjustment of garage door travel limits will interfere with proper operation of safety reversal system.
- After ANY adjustments are made, the safety reversal system **MUST** be tested. Door **MUST** reverse on contact with 1-1/2" high (3.8 cm) object (or 2x4 laid flat) on floor.

CAUTION

To prevent damage to vehicles, be sure fully open door provides adequate clearance.

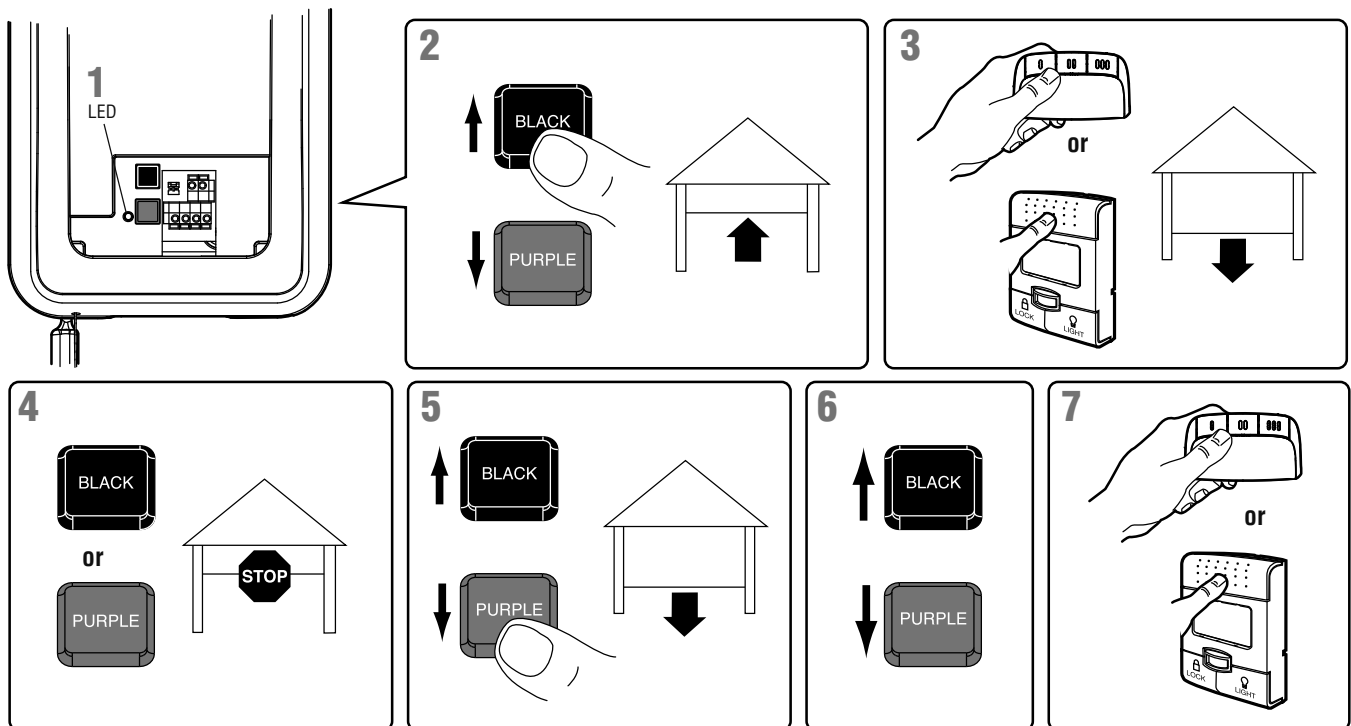

Adjustment

2 Set the Force

The force setting measures the amount of force required to open and close the door.

- 1 Push the purple button twice to enter into the Force Adjustment Mode. The LED will flash quickly.
- 2 Push the door control or programmed remote control. The door will close (DOWN).
- 3 Push the door control or programmed remote control again. The door will open (UP).
- 4 Push the door control or programmed remote control a third time to close the door (DOWN).

The LED will stop flashing when the force has been programmed.

The door must travel through a complete cycle, up and down, in order for the force to be set properly. If the garage door opener cannot open and close the door fully, inspect the door to ensure that it is balanced properly and is not sticking or binding.

If the door is not stopping exactly where you would like it, repeat *Program the Travel Limits*.

⚠ WARNING

Without a properly installed safety reversal system, persons (particularly small children) could be **SERIOUSLY INJURED** or **KILLED** by a closing garage door.

- NEVER learn forces or limits when door is binding or sticking. Repair door first.
- Too much force on garage door will interfere with proper operation of safety reversal system.
- After ANY adjustments are made, the safety reversal system **MUST** be tested. Door **MUST** reverse on contact with 1-1/2" high (3.8 cm) object (or 2x4 laid flat) on floor.

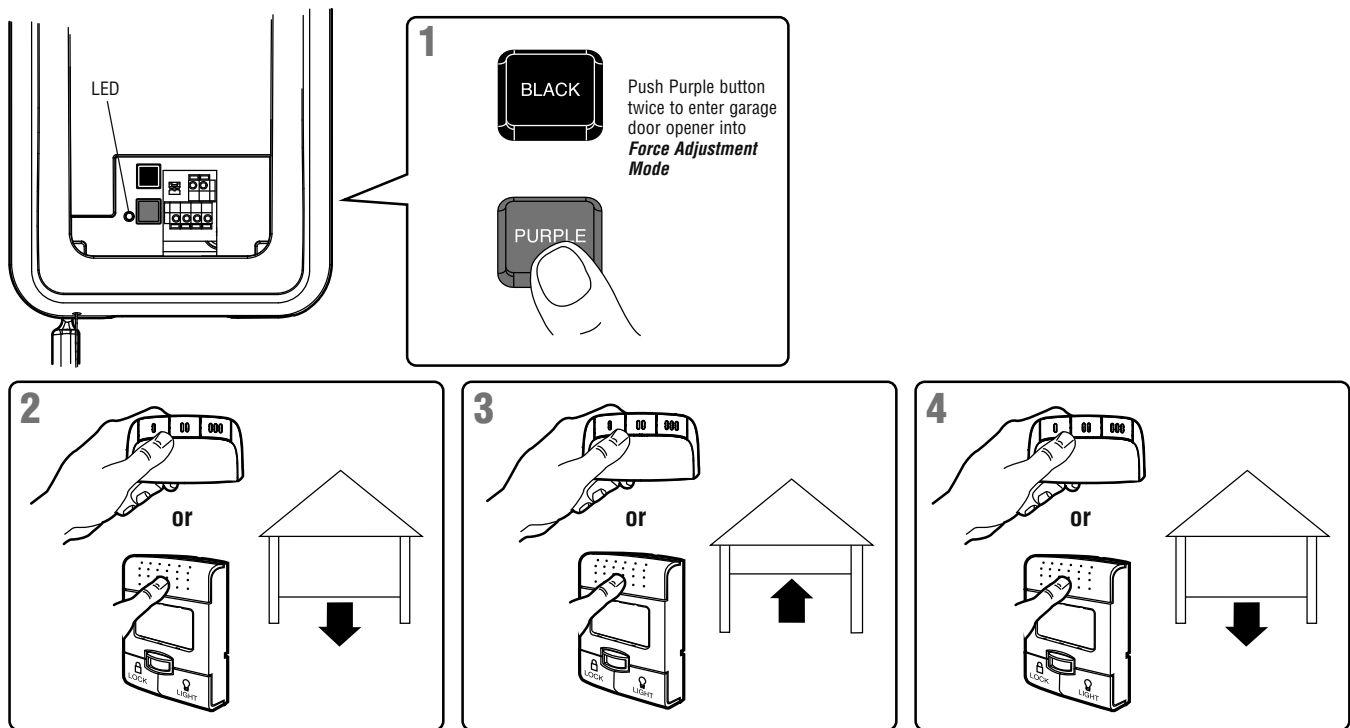

Adjustment

3 Test the Safety Reversal System

TEST

With the door fully open, place a 1-1/2 inch (3.8 cm) board (or a 2x4 laid flat) on the floor, centered under the garage door.

Operate the door in the down direction. The door must reverse on striking the obstruction. Upon successful safety reversal test proceed to Adjustment Step 4.

ADJUST

If the door stops on the obstruction, it is not traveling far enough in the down direction. Complete Adjustment Steps 1 and 2 *Program the Travel Limits* and *Set the Force*.

Repeat the test.

When the door reverses on the 1-1/2 inch (3.8 cm) board (or 2x4 laid flat), remove the obstruction and run the garage door opener through 3 or 4 complete travel cycles to test adjustment.

If the garage door opener continues to fail the Safety Reverse Test, call for a trained door systems technician.

IMPORTANT SAFETY CHECK:

Test the Safety Reverse System after:

- Each adjustment of limits, or force controls.
- Any repair to or adjustment of the garage door (including springs and hardware).
- Any repair to or buckling of the garage floor.
- Any repair to or adjustment of the opener.

4 Test the Protector System®

- Press the remote control push button to open the door.
- Place the opener carton in the path of the door.
- Press the remote control push button to close the door. The door will not move more than an inch, and the opener lights will flash.

The garage door opener will not close from a remote if the indicator light in either sensor is off (alerting you to the fact that the sensor is misaligned or obstructed).

If the garage door opener closes the door when the safety reversing sensor is obstructed, do not operate the door. Call for a trained door systems technician.

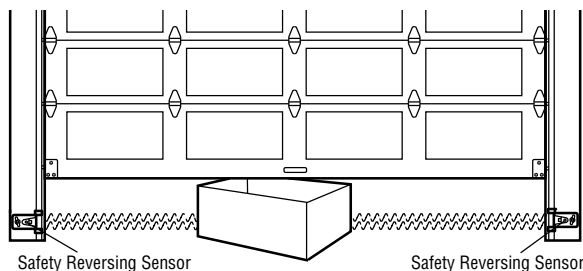

⚠ WARNING

Without a properly installed safety reversal system, persons (particularly small children) could be SERIOUSLY INJURED or KILLED by a closing garage door.

- Safety reversal system MUST be tested every month.
- If one control (force or travel limits) is adjusted, the other control may also need adjustment.
- After ANY adjustments are made, the safety reversal system MUST be tested. Door MUST reverse on contact with 1-1/2" (3.8 cm) high object (or 2x4 laid flat) on the floor.

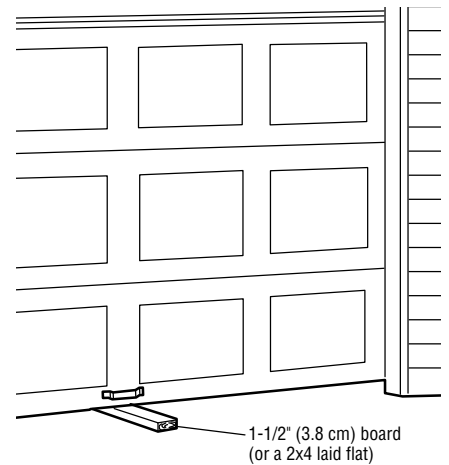

⚠ WARNING

Without a properly installed safety reversing sensor, persons (particularly small children) could be SERIOUSLY INJURED or KILLED by a closing garage door.

Adjustment

5 Test Cable Tension Monitor

If your cable tension monitor has been activated the LED on the garage door opener will blink 9 times.

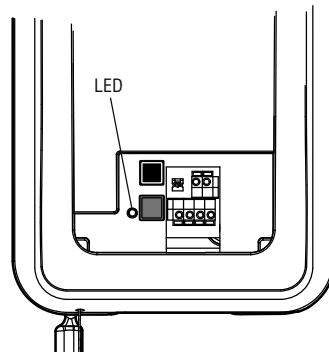

⚠ WARNING

To prevent possible **SERIOUS INJURY** or **DEATH** from a falling garage door:

- If possible, use emergency release handle to disengage door **ONLY** when garage door is **CLOSED**. Weak or broken springs or unbalanced door could result in an open door falling rapidly and/or unexpectedly.
- **NEVER** use emergency release handle unless garage doorway is clear of persons and obstructions.

6 Test Power Door Lock

1. With the door fully closed, the power door lock bolt should be protruding through the track.
2. Operate the door in the open direction. The power door lock should retract before the door begins to move.
3. Operate the door in the down direction. When the door reaches the fully closed position, the power door lock should automatically activate to secure the door.

NOTE: If the power door lock does not function, the lock can be manually released by sliding the manual release handle to the open position.

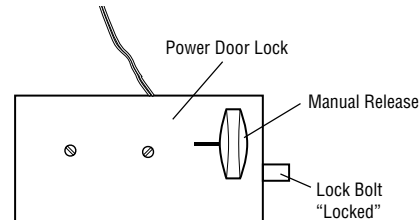

7 To Open the Door Manually

Disengage door lock before proceeding. The door should be fully closed if possible. Pull down on the emergency release handle until a click noise is heard from the garage door opener and lift the door manually.

To reconnect the door to the garage door opener, pull the emergency release handle straight down a second time until a click noise is heard from the garage door opener. The door will reconnect on the next UP or DOWN operation.

Test the emergency release:

1. Make sure the garage door is closed.
2. Pull the emergency release handle. The garage door should then be able to be opened manually.
3. Return the door to the closed position.
4. Pull the emergency handle a second time.
5. Reconnect the door to the garage door opener.

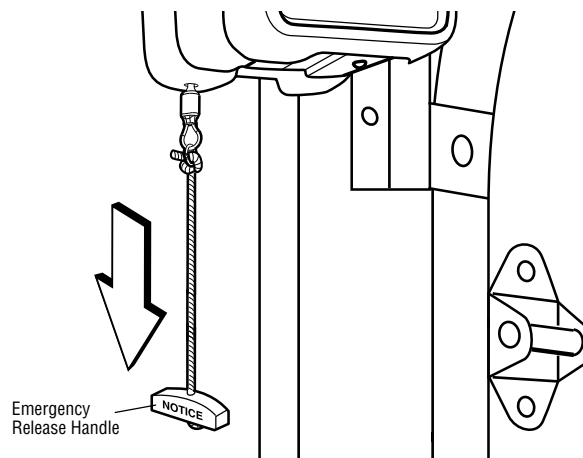

Operation

IMPORTANT SAFETY INSTRUCTIONS

WARNING

To reduce the risk of SEVERE INJURY or DEATH:

1. READ AND FOLLOW ALL WARNINGS AND INSTRUCTIONS.
2. ALWAYS keep remote controls out of reach of children. NEVER permit children to operate or play with door control push buttons or remote controls.
3. ONLY activate door when it can be seen clearly, it is properly adjusted and there are no obstructions to door travel.
4. ALWAYS keep door in sight until completely closed. NO ONE SHOULD CROSS THE PATH OF THE MOVING DOOR.
5. NO ONE SHOULD GO UNDER A STOPPED, PARTIALLY OPENED DOOR.
6. If possible, use emergency release handle to disengage door ONLY when door is CLOSED. Weak or broken springs or unbalanced door could result in an open door falling rapidly and/or unexpectedly, causing SEVERE INJURY or DEATH.
7. NEVER use emergency release handle unless doorway is clear of persons and obstructions.
8. After ANY adjustments are made, the safety reversal system MUST be tested. Failure to adjust the garage door opener properly may cause SEVERE INJURY or DEATH.
9. Safety reversal system MUST be tested every month. Door MUST reverse on contact with 1-1/2" (3.8 cm) high object (or a 2x4 laid flat) on the floor. Failure to adjust the garage door opener properly may cause SEVERE INJURY or DEATH.
10. ALWAYS KEEP DOOR PROPERLY BALANCED (see page 3). An improperly balanced door may NOT reverse when required and could result in SEVERE INJURY or DEATH.
11. ALL repairs to cables, spring assemblies and other hardware, ALL of which are under EXTREME tension, MUST be made by a trained door systems technician.
12. ALWAYS disconnect electric power to garage door opener BEFORE making ANY repairs or removing covers.
13. **SAVE THESE INSTRUCTIONS.**

Using Your Garage Door Opener

Your Security+® garage door opener and hand-held remote control have been factory-set to a matching code which changes with each use, randomly accessing over 100 billion new codes. Your garage door opener will operate with up to eight Security+® remote controls and one Security+® Keyless Entry System. If you purchase a new remote, or if you wish to deactivate any remote, follow the instructions in the *Programming* section.

Activate your garage door opener with any of the following:

- *The hand-held Remote Control:* Hold the large push button down until the door starts to move.
- *The wall-mounted Door Control:* Hold the push button or bar down until the door starts to move.
- *The Keyless Entry (See Accessories):* If provided with your garage door opener, it must be programmed before use. See Programming.

When the garage door opener is activated (with the safety reversing sensor correctly installed and aligned).

- If open, the door will close. If closed, it will open.
- If closing, the door will reverse.
- If opening, the door will stop.
- If the door has been stopped in a partially open position, it will close.
- If obstructed while closing, the door will reverse. If the obstruction interrupts the sensor beam, the garage door opener lights will blink for five seconds.
- If obstructed while opening, the door will stop.
- If fully open, the door will not close when the beam is broken. The sensor has no effect in the opening cycle.

If the sensor is not installed, or is misaligned, the door won't close from a hand-held remote. However, you can close the door with the Door Control, the Outside Keylock, or Keyless Entry, *if you activate them until down travel is complete*. If you release them too soon, the door will reverse.

The garage door opener lights will turn on when the garage door opener is activated. They will turn off automatically after 4-1/2 minutes or provide constant light when the Light feature on the Smart Control Panel® is activated. Bulb size is A19. Bulb power is 100 watts maximum.

Security+® light feature: Lights will also turn on when someone walks through the open garage door. With a Smart Control Panel®, this feature may be turned off as follows: With the garage door opener lights off, press and hold the light button for 10 seconds, until the light goes on, then off again. To restore this feature, start with the garage door opener lights on, then press and hold the light button for 10 seconds until the light goes off, then on again.

Operation

Using the Smart Control Panel®

Press the push bar to open or close the door. Press again to reverse the door during the closing cycle or to stop the door while it's opening.

This door control contains a motion sensing detector that will automatically turn on the light when it detects a person entering the garage.

Light feature

Press the Light button to turn the garage door opener light on or off. It will not control the garage door opener lights when the door is in motion. If you turn it on and then activate the garage door opener, the light will remain on for 4-1/2 minutes.

Press again to turn it off sooner. The 4-1/2 minute interval can be changed to 1-1/2, 2-1/2, or 3-1/2 minutes as follows: Press and hold the Lock button until the light blinks (about 10 seconds). A single blink indicates that the timer is reset to 1-1/2 minutes. Repeat the procedure and the light will blink twice, resetting the timer to 2-1/2 minutes. Repeat again for a 3-1/2 minute interval, etc., up to a maximum of four blinks and 4-1/2 minutes. When using the garage door opener lights as working lights, we recommend that you first disable the motion sensor. See *Automatic Light Feature*, below.

Motion Sensing (Automatic Light Feature)

The garage door opener light will turn on automatically when a person enters the garage. When a person walks in front of the door control, the light will come on for five minutes, then shut off. This feature works by detecting body heat.

To disable this feature, push the motion sensing button on the side of the door control.

We recommend that you disable the motion sensor when using the garage door opener lights as working lights. Otherwise, they will turn off automatically if you are working beyond the sensors range.

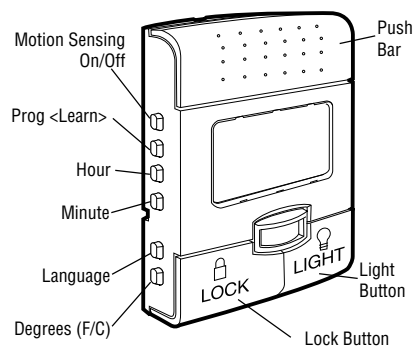

Lock feature

Designed to prevent operation of the door from hand-held remote controls. However, the door will open and close from the Door Control, the Outdoor Key Switch and the Keyless Entry Accessories. To activate, press and hold the Lock button for 2 seconds. To turn off, press and hold the Lock button again for 2 seconds. The Lock feature will also turn off whenever the "learn" button on the garage door opener panel is activated.

(PROG) Learn Feature

The door control is equipped with a Prog <LEARN> button to assist in learning remote controls to the garage door opener. Press the Prog <LEARN> button once to initiate LEARN mode and the display will show 'Learn Remote Control - Press Learn Button Again to Confirm'. Press the Prog <LEARN> button a second time and the display will show 'Learn Mode - Press Remote Control Button to Learn Remote.' Press the button of the remote control to be learned and the worklight will blink to confirm the remote control has been learned.

Hour & Minute Feature

Press or hold either of these side buttons to increment the hour or minute displayed on the LCD display.

(LANG) Language Feature

Press this side button to toggle between the three languages - English, French and Spanish.

Degrees F/C Feature

Press this side button to toggle the temperature units between Fahrenheit and Celsius.

Display Contrast Adjustment

Press and hold the light button then push the hour button to increase the contrast or the minute button to decrease the contrast.

Operation

Using the Remote Control

Press and hold the button down until the door or gate starts to move. The remote control will operate from up to 3 car lengths away on typical installations. Installations and conditions vary, contact an installing dealer for more information.

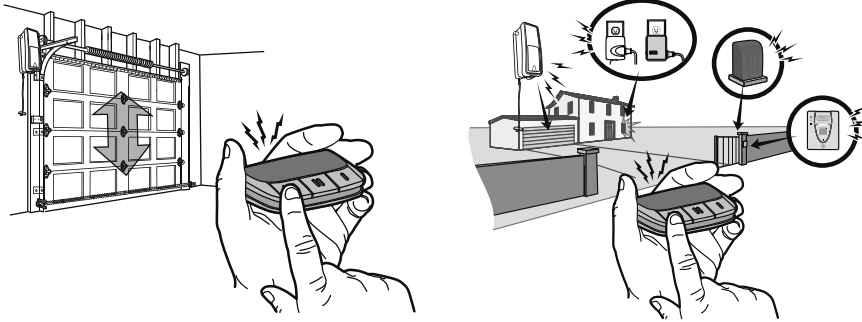

3-Button Remote Controls

Additional buttons on the remote control can be programmed to operate up to 3 devices such as additional garage door openers, light controls, gate operators or access control systems.

To Control the Opener Lights

Additional buttons on the remote control can be programmed to operate the garage door opener lights without opening the door.

1. With the door closed, press and hold the remote button that you want to control the light.
2. Press and hold the Light button on the Smart Control Panel®.
3. Press and hold the Lock button on the Smart Control Panel®.
4. After the opener lights flash, release all buttons.

Test by pressing the remote push button. The opener lights should turn on or off but the door should not move.

The Remote Control Battery

The LED(s) on your remote control will stop flashing when the battery is low and needs to be replaced. To replace battery, open the case as shown. Insert battery positive side up (+). Replace the battery with only 3V2016 coin cell batteries. Dispose of old battery properly.

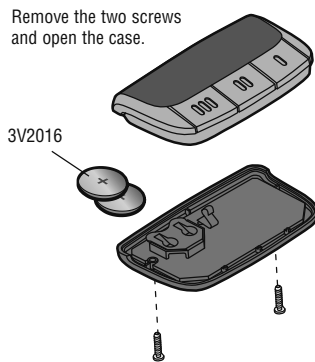

⚠ WARNING

To prevent possible **SERIOUS INJURY** or **DEATH**:

- NEVER allow small children near batteries.
- If battery is swallowed, immediately notify doctor.

To reduce risk of fire, explosion or chemical burn:

- Replace **ONLY** with 3V2016 coin batteries.
- **DO NOT** recharge, disassemble, heat above 100° C (212° F) or incinerate.

NOTICE: To comply with FCC and or Industry Canada (IC) rules, adjustment or modifications of this receiver and/or transmitter are prohibited, except for changing the code setting or replacing the battery. **THERE ARE NO OTHER USER SERVICEABLE PARTS.**

Tested to Comply with FCC Standards FOR HOME OR OFFICE USE. Operation is subject to the following two conditions: (1) this device may not cause harmful interference, and (2) this device must accept any interference received, including interference that may cause undesired operation.

Operation

Care of Your Garage Door Opener

MAINTENANCE SCHEDULE

Once a Month

- Manually operate door. If it is unbalanced or binding, call a trained door systems technician.
- Check to be sure door opens and closes fully. Adjust limits and/or force if necessary (see Adjustment Steps 1 and 2).
- Repeat the safety reverse test. Make any necessary adjustments (see Adjustment Step 3).

Once a Year

- Oil door rollers, bearings and hinges. The garage door opener does not require additional lubrication. Do not grease the door tracks.

Troubleshooting

The garage door opener doesn't operate from either the Door Control or the remote control:

- Does the garage door opener have electric power? Plug a lamp into the outlet. If it doesn't light, check the fuse box or the circuit breaker. (Some outlets are controlled by a wall switch.)
- Have you disabled all door locks? Review installation instruction warnings on page 7.
- Is there a build-up of ice or snow under the door? The door may be frozen to the ground. Remove any restriction.
- The garage door spring may be broken. Have it replaced (see page 3 for reference).

Garage door opener operates from the remote, but not from the Door Control:

- Is the door control lit? If not, reverse the wires. If the garage door opener runs, check for a faulty wire connection at the door control, a short under the staples, or a broken wire.
- Are the wiring connections correct? Review Installation Step 5, page 11.

The door operates from the Door Control, but not from the remote control:

- Is the door push bar flashing? If so, Lock mode is engaged. Make sure it is off by pressing the Lock button for two seconds.
- Program the garage door opener to match the remote control code. (Refer to instructions on the garage door opener panel.) Repeat with all remote controls.

The remote control has short range:

- Change the location of the remote control in your car.
- Check to be sure the antenna on the side or back panel of the garage door opener extends fully downward.
- Some installations may have shorter range due to a metal door, foil backed insulation, or metal garage siding.

The garage door opens and closes by itself:

- Be sure that all remote control push buttons are off.
- Remove the bell wire from the door control terminals and operate from the remote only. If this solves the problem, the door control is faulty (replace), or there is an intermittent short on the wire between the door control and the garage door opener.
- Clear memory and re-program all remote controls.

The door doesn't open completely:

- Check power door lock.
- Is something obstructing the door? Is it out of balance, or are the springs broken? Remove the obstruction or repair the door.

Operation

Troubleshooting (Continued)

The door opens but won't close:

- Check cable tension monitor (see Installation Step 4).
- If the garage door opener lights blink, check the safety reversing sensor (see Installation Step 9).
- If the garage door opener lights don't blink and it is a new installation (see Adjustment Step 2). For an existing installation, see below.

Repeat the safety reverse test after the adjustment is complete.

The door reverses for no apparent reason and garage door opener lights don't blink:

- Check cable tension monitor (see Installation Step 4).
- Is something obstructing the door? Pull the emergency release handle. Operate the door manually. If it is unbalanced or binding, call a trained door systems technician.
- Clear any ice or snow from the garage floor area where the door closes.
- Review Adjustment Step 2.

Repeat safety reverse test after adjustments.

The door reverses for no apparent reason and garage door opener lights blink for 5 seconds after reversing:

- Check the safety reversing sensor. Remove any obstruction or align the receiving eye (see Installation Step 9).

The garage door opener strains to operate door:

- The door may be out of balance or the springs may be broken. Close the door and use the emergency release handle to disconnect the door. Open and close the door manually. A properly balanced door will stay in any point of travel while being supported entirely by its springs. If it does not, disconnect the garage door opener and call a trained door systems technician.

The garage door opener motor hums briefly, then won't work:

- The garage door springs may be broken. See above.
- If the problem occurs on the first operation of the garage door opener, door may be locked. Disable the power door lock.

The garage door opener won't operate due to power failure:

- Manually open the power door lock.
- Use the emergency release handle to disconnect the door. The door can be opened and closed manually. When power is restored, pull manual release a second time.
- If a Standby Power Unit is connected, the opener should be able to operate up to 20 times without power.

Door loses limits.

- Collar not tightened securely. Tighten collar (see Assembly Steps 1 and 2) and reprogram limits (see Adjustment Step 1).

The garage door opener moves when the door is in operation:

- Some minor movement is normal for this product. If it is excessive the collar will wear prematurely.
- Check to make sure the torsion bar is not moving left/right excessively.
- Check to make sure the torsion bar is not visibly moving up and down as it rotates.
- Check that the opener is mounted at a right angle to the jackshaft. If not, move the position of the mounting bracket.

Power lock makes noise when operating.

- Call LiftMaster® dealer for replacement power lock.

Operation

Smart Control Panel® Messages

The following messages are contained within the Smart Control Panel® and may appear during the operations of the garage door opener:

MESSAGE

Safety Sensors check alignment, blockage or miswiring see owner's manual

Meaning: This message will appear if the safety reversing sensors are out of alignment, if they are blocked or if the wiring is disconnected. To clear message from door control do the following:

- Check to see that area is clear between the safety reversing sensors.
- Check to see that the safety reversing sensors are not misaligned.
- Realign receiving eye sensor, clean lens and secure brackets.
- Verify door track is firmly secured to wall and does not move.
- Check to see that the safety reversing sensors' wires are connected to the garage door opener.
- If message has not cleared after the above checks, refer to message #2.

MESSAGE

Safety Sensors malfunction check miswiring see owner's manual

Meaning: This message will appear if the Safety Reversing Sensors are miswired. To clear the message, do the following:

- Inspect the safety reversing sensor wires for a short (staple in wire), correct wiring polarity (black/white wires reversed), replace/attach as needed.
- Disconnect all wires from back of garage door opener.
- Remove safety reversing sensors from brackets and shorten sensor wires to 1-2 feet (30-60 cm) from back of each sensor.
- Reattach sending eye to garage door opener using shortened wires. If sending eye indicator light glows steadily, attach the receiving eye.
- Align sensors, if the indicator lights glow replace the wires for the sensors. If the sensor indicator lights do not light, replace the safety reversing sensors.

MESSAGE

Learn remote control press LEARN button to confirm

Meaning: This message will appear when the 'LEARN' button has been pressed on the door control. Pressing the 'LEARN' button again will allow the user to program an additional remote control to the opener.

MESSAGE

Learn mode press remote control button to program remote

Meaning: This message will appear when the 'learn' button has been pressed a second time on the door control or anytime on the garage door opener. The garage door opener is ready to program another remote control by simply pressing the remote control button. Once the opener has 'LEARNED' the remote control, the worklight will blink one time.

MESSAGE

Lock mode remote control locked out press LOCK button to enable remote

Meaning: This message will appear when the 'Lock' button has been pressed and held for more than one second. This feature will disable the garage door opener from receiving remote control signals. To exit 'LOCK' mode, press and hold the button for more than one second.

MESSAGE

English, Français and Español

Meaning: This message will appear when the 'Language' button has been pressed. Pressing the button will toggle to the next language.

MESSAGE

*Motion sensing on
Motion sensing off*

Meaning: This message will appear when the Motion Sensing button is pressed. The motion detector will toggle on or off with each press of the button.

MESSAGE

Battery backup enabled

Meaning: Opener is running on battery power.

MESSAGE

Battery backup enabled

Meaning: Opener is running on battery power with full charge.

MESSAGE

*Battery low
Battery backup enabled*

Meaning: Opener is running on battery power with low charge.

MESSAGE

Battery bad replace battery now see owner's manual

Meaning: Battery is beyond a recoverable condition.

MESSAGE

Power restored battery recharging

Meaning: Battery charging from recent battery backup state.

Operation

Your garage door opener is programmed with self-diagnostic capabilities. The diagnostic LED will flash a number of times, then pause, signifying it has found a potential issue. Consult Diagnostic Chart below.

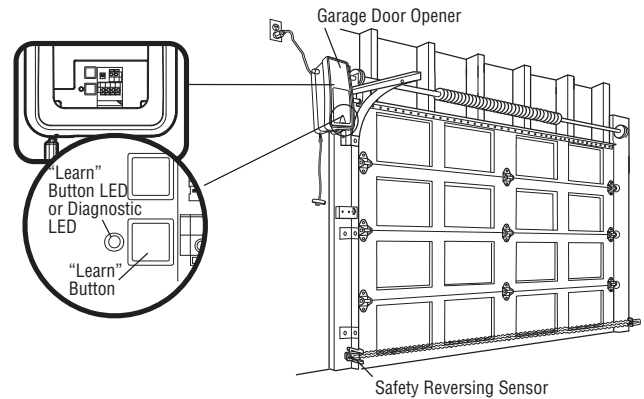
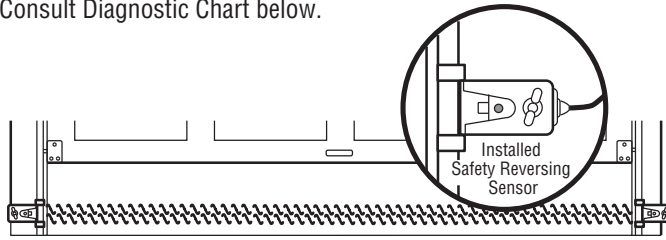

Diagnostic Chart

1 FLASH

Safety reversing sensors wire open (broken or disconnected)

OR

2 FLASHES

Safety reversing sensors wire shorted or black/white wire reversed

3 FLASHES

Door control or wire shorted

4 FLASHES

Safety reversing sensors slightly misaligned (dim or flashing LED)

5 FLASHES

Motor RPM is not recognized

9 FLASHES

Cable tension monitor reversal

10 FLASHES

Limits and forces need reprogramming

11 FLASHES

Limits and forces need reprogramming

12 FLASHES

Attempting to compensate

13 FLASHES

Attempting to compensate

SYMPTOM: One or both of the Indicator lights on the safety sensors do not glow steady.

- Inspect sensor wires for a short (staple in wire), correct wiring polarity (black/white wires reversed), broken or disconnected wires, replace/attach as needed.
- Disconnect all wires from back of garage door opener.
- Remove sensors from brackets and shorten sensor wires to 1-2 ft. (30-60 cm) from back each of sensor.
- Reattach sending eye to garage door opener using shortened wires. If sending eye indicator light glows steadily, attach the receiving eye.
- Align sensors, if the indicator lights glow replace the wires for the sensors. If the sensor indicator lights do not light, replace the safety reversing sensors.

SYMPTOM: The door doesn't activate from the door control.

- Inspect door control/wires for a short (staple in wire), replace as needed.
- Disconnect wires at door control, touch wires together. If garage door opener activates, replace door control.
- If garage door opener does not activate, disconnect door control wires from garage door opener. Momentarily short across red and white terminals with jumper wire. If garage door opener activates, replace door control wires.

SYMPTOM: Sending indicator light glows steadily, receiving indicator light is dim or flashing.

- Realign receiving eye sensor, clean lens and secure brackets.
- Verify door track is firmly secured to wall and does not move.

SYMPTOM: Door travels 2-3 inches and stops.

- Reprogram limits and forces. See Adjustment section.
- If the motor unit continues to travel 2-3 inches, check the travel module connection or replace the travel module.

SYMPTOM: No movement, motor runs 2-3 seconds.

- Reconnect the emergency release.
- Motor may need to be replaced.

SYMPTOM: Door stops and reverses while closing.

- Check for possible door obstructions and remove.
- Check that the cable tension monitor is properly connected to the opener.
- Replace the cable tension monitor.

SYMPTOM: Door stops while opening.

- Reprogram limits and forces. See Adjustment section.

SYMPTOM: Door stops and reverses while closing.

- Reprogram limits and forces. See Adjustment section.

SYMPTOM: Door stops and reverses while closing.

- Garage door opener will try to compensate three times before turning to a 10 Flash.

SYMPTOM: Door stops while opening.

- Garage door opener will try to compensate three times before turning to a 11 Flash.

Programming

Your garage door opener has already been programmed at the factory to operate with your hand-held remote control. The door will open and close when you press the button shown.

Below are instructions for programming your garage door opener to operate with additional 895MAX remote controls. To program additional remote controls, refer to the instructions provided with the remote control.

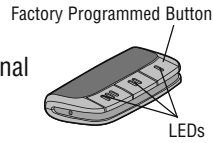

NOTICE: If this Security+® garage door opener is operated with a non-rolling code transmitter, the technical measure in the receiver of the garage door opener, which provides security against code-theft devices, will be circumvented. The owner of the copyright in the garage door opener does not authorize the purchaser or supplier of the non-rolling code transmitter to circumvent that technical measure.

To Add or Reprogram a Hand-held Remote Control (Model 895MAX)

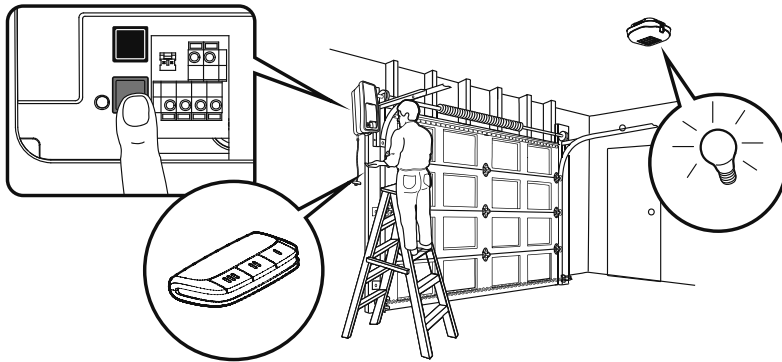

- 1 To enter programming mode, press the Program button until the LEDs on the front of the remote control turn on.

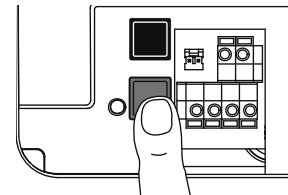
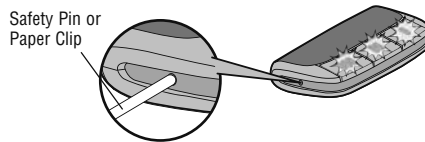

USING THE SMART CONTROL PANEL®

- 2 Press and release the Prog <Learn> button on the Smart Control Panel® **twice**. Within 30 seconds...

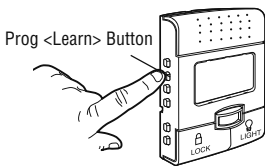

OR

USING THE "LEARN" BUTTON

- 2 Press and release the Learn button on the garage door opener. The Learn LED will light. Within 30 seconds...

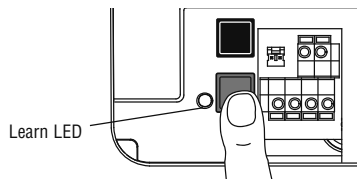

- 3 Press and release the remote control button you want to use... Check to see if the garage door opener light bulb blinks. If not, wait for the remote control LED to light solid then **slowly** press and release the remote control button again. **Repeat** until the light bulb blinks. **DO NOT** press the button after the light bulb blinks.

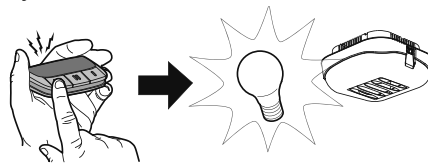

- 4 To exit programming mode, press any remote control button **except** the button that was just programmed.

Programming

To Add, Reprogram or Change a Keyless Entry PIN

NOTE: Your new Keyless Entry must be programmed to operate your garage door opener.

USING THE “LEARN” BUTTON

- 1 Press and release the purple “learn” button on garage door opener. The learn indicator light will glow steadily for 30 seconds.
- 2 Within 30 seconds, enter a four digit personal identification number (PIN) of your choice on the keypad. Then press and hold the ENTER button.
- 3 Release the button when the remote light blinks. It has learned the code. If light bulbs are not installed, two clicks will be heard.

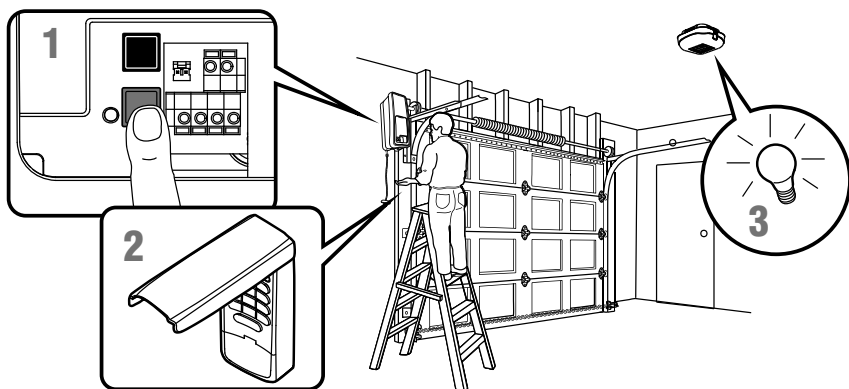

USING THE DOOR CONTROL

- 1 Press the Prog <Learn> button on the door control.
- 2 Press the Prog <Learn> button again to confirm Learn Mode.
- 3 Enter a four digit personal identification number (PIN) of your choice on the keypad. Then press ENTER.
- 4 When the remote light blinks, it has learned the code. If light bulbs are not installed, two clicks will be heard.

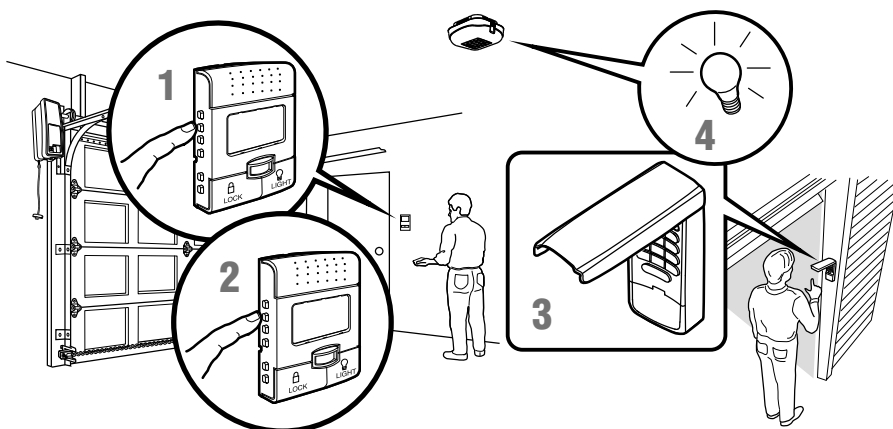

One Button Close:

The garage door opener can be closed by pressing only the ENTER button if the one button close feature has been activated. This feature has been activated at the factory. To activate or deactivate this feature press and hold buttons 1 and 9 for 10 seconds. The keypad will blink twice when the one button close is active. The keypad will blink four times when one button close is deactivated.

To change an existing, known PIN

If the existing PIN is known, it may be changed by one person without using a ladder.

1. Press the four buttons for the present PIN, then press and hold the # button.

The garage door opener light will blink twice. Release the # button.

2. Press the new 4-digit PIN you have chosen, then press ENTER.

The garage door opener lights will blink once when the PIN has been learned.

Test by pressing the new PIN, then press ENTER. The door should move.

To set a temporary PIN

You may authorize access by visitors or service people with a temporary 4-digit PIN. After a programmed number of hours or number of accesses, this temporary PIN expires and will no longer open the door. It can be used to close the door even after it has expired. To set a temporary PIN:

1. Press the four buttons for your personal entry PIN (not the last temporary PIN), then press and hold the * button.

The remote light will blink three times. Release the button.

2. Press the temporary 4-digit PIN you have chosen, then press ENTER.

The garage door opener light will blink four times.

3. To set the number of hours this temporary PIN will work, press the number of hours (up to 255), then press *.

OR

3. To set the number of times this temporary PIN will open door, press the number of times (up to 255), then press #.

The remote light will blink once when the temporary PIN has been learned.

Test by pressing the four buttons for the temporary PIN, then press ENTER. The door should move. If the temporary PIN was set to a certain number of openings, remember that the test has used up one opening. To clear the temporary password, repeat steps 1-3, setting the number of hours or times to 0 in step 3.

Programming

Reprogramming Light or Additional Light

Your garage door opener remote light has already been programmed at the factory to operate with your opener. Any additional or replacement remote lights will need to be programmed.

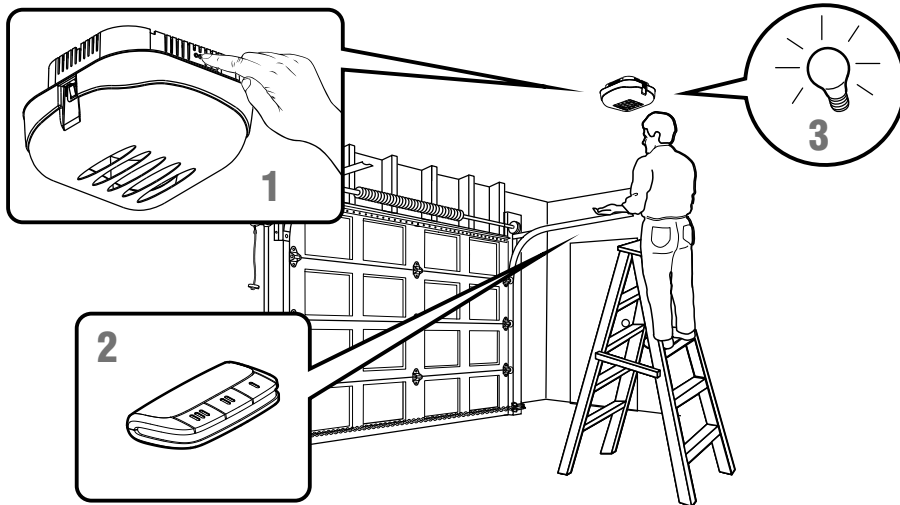

- 1** Press and the “learn” button on the light until the LED comes ON.
- 2** Activate the garage door opener using the hand-held remote, door control, or keyless entry.
- 3** The code has been learned when the remote light comes on.

Repair Parts

Installation Parts

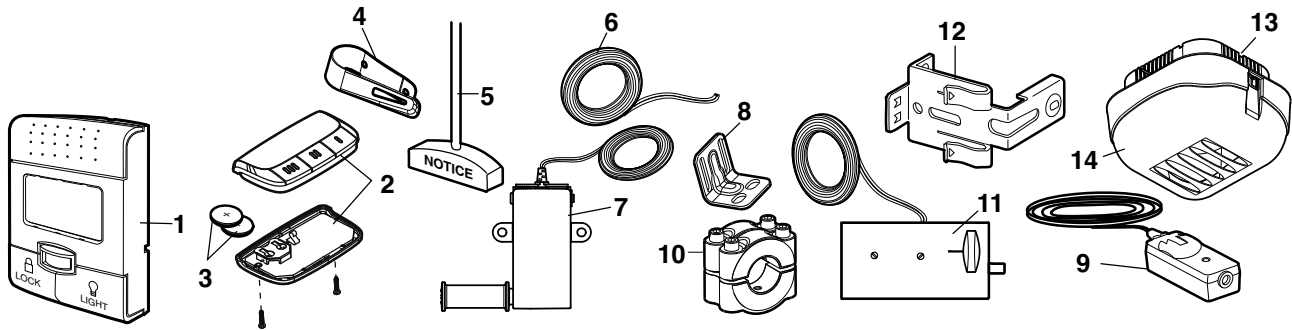

KEY NO.	PART NO.	DESCRIPTION	KEY NO.	PART NO.	DESCRIPTION
1	398LM	Smart Control Panel®	10	41A6388	Collar with set screws (2)
2	895MAX	3-Button remote control	11	41A6102	Power door lock
3	10A19	3V2016 lithium battery: led and garage door opener	12	41A5266-1	Safety sensor brackets (2)
4	29C151	Remote control visor clip	13	380LM	Remote Light (garage door opener light)
5	41A4582	Emergency release rope & handle assembly	14	41D96-1	Light lens for light
6	41B4494-1	2-Conductor bell wire - white & white/red			NOT SHOWN
7	41A6104	Cable tension monitor		101D173	Push bar for door control
8	41C0902	Mounting bracket		41A6288	Hardware bag for light
9	41A5034	Safety sensor kit (receiving and sending eyes) with 3 feet (.9 m) 2-conductor bell wire attached		41A6298	Installation hardware bag (includes hardware listed on page 5)
				114A3489	Owner's manual
				114A3489SP	Owner's manual - Spanish

Repair Parts

Garage Door Garage Door Opener Assembly Parts

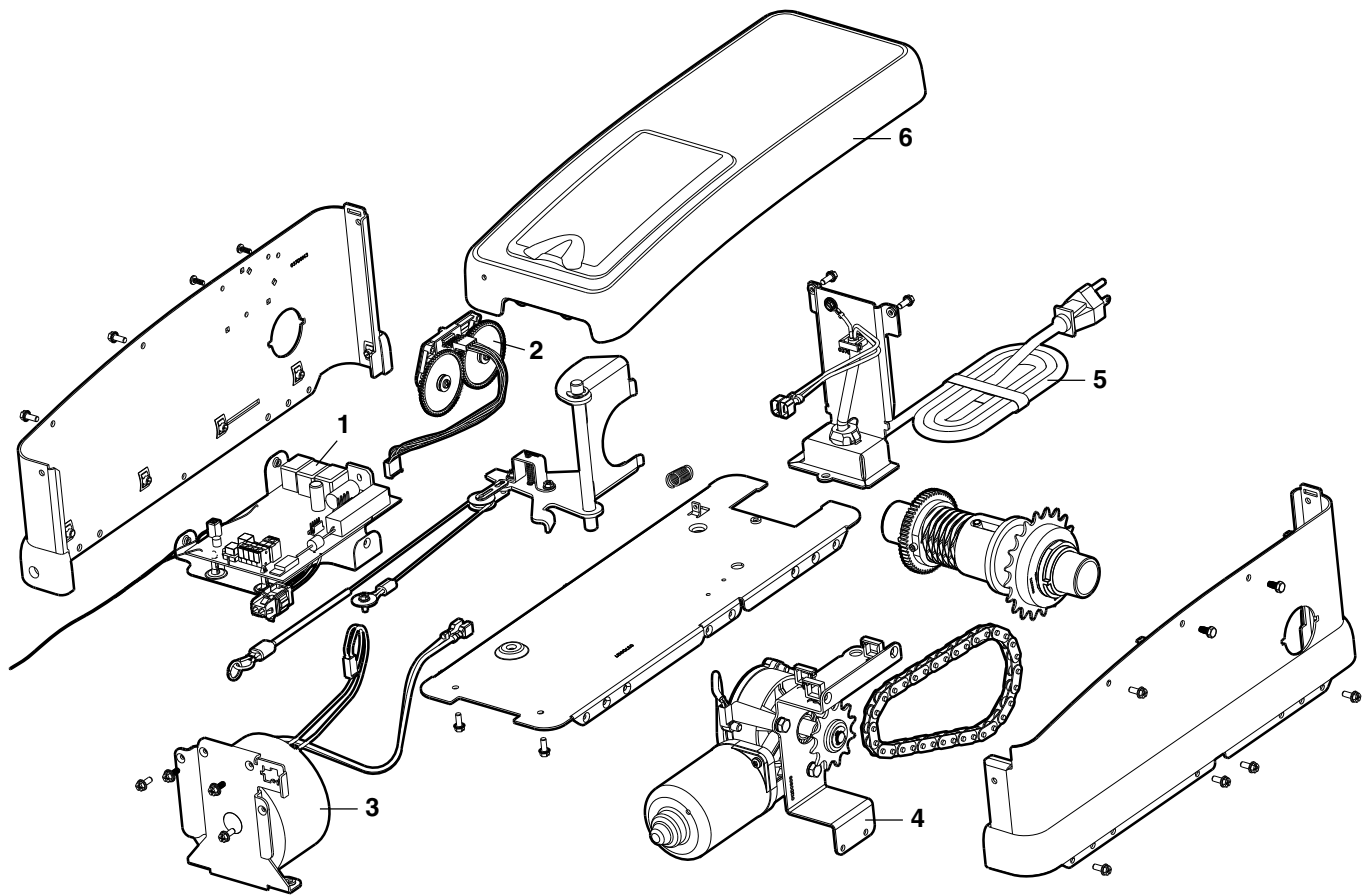

KEY NO.	PART NO.	DESCRIPTION	KEY NO.	PART NO.	DESCRIPTION
1	41DJ001	Logic board complete with plate	4	41A6095	Motor with bracket
2	41A6408	Travel Module	5	41B122	Power cord
3	41C168	Transformer	6	41A6348-3	Cover

Accessories

41A5281

Extension Brackets:

(Optional) For safety reversing sensor installation onto the wall or floor.

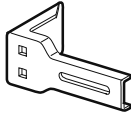

377LM

Keyless Entry with Security+® (Ⓢ):

Enables homeowner to operate garage door garage door opener from outside by entering a password on a specially designed keyboard. Also can add a temporary password for visitors or service persons. This temporary password can be limited to a programmable number of hours or entries.

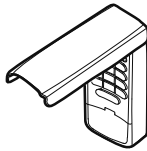

902LM/903LM

2 & 3 Door Multi-Function Door Control:

Ideal for homes with up to three garage doors. Combine up to three controls into one door control panel for a neat compact appearance. Enhanced functions include Lock Feature to lock out outside radio signals while you are away from home and turn garage door opener lights on or off from the control panel.

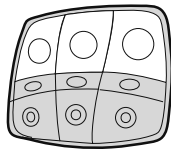

370LM

3-Button Mini-Remote Control with Security+® (Ⓢ):

With key ring.



373LM

3-Button Security+® Remote Control (Ⓢ):

Includes visor clip.



975LM

Laser Park Assist:

Laser enables homeowners to precisely park vehicles in the garage.

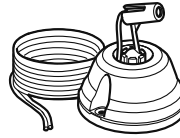

380LM

Remote Light:

Enables homeowner to turn on a work light from their car with their garage door opener remote or from anywhere in their home with an additional LiftMaster Security+® remote.

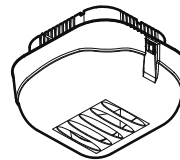

378LM

Wireless Door Control:

Push bar, light feature and auxiliary button. Includes battery.



395LM

Remote Light Control (Ⓢ):

Enables homeowner to turn on a lamp, television or other appliance from their car with their garage door opener remote or from anywhere in their home with an additional LiftMaster Security+® remote.

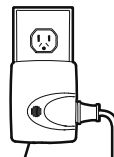

475LM

EverCharge® Standby Power System:

Provides backup power to the model 3800 garage door openers.

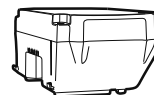

916LM

Garage Door Monitor Sensor:

Additional accessory sensor for homes with multiple garage doors.



915LM

Garage Door Monitor:

Security for the largest door of your home!

Tells you if your garage door is open or closed. Monitors up to 4 garage doors by adding additional sensor modules.



895MAX

3-Button Remote Control:

Includes visor clip.



480LM

Alternate Mounting Kit:

This kit allows model 3800 to be mounted below the torsion bar in the case where the torsion bar is not round or the normal mounting area is obstructed.

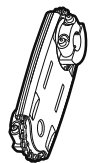

LIFTMASTER® SERVICE IS ON CALL

OUR LARGE SERVICE ORGANIZATION
SPANS AMERICA

INSTALLATION AND SERVICE INFORMATION IS AS NEAR AS YOUR
TELEPHONE.

SIMPLY DIAL OUR TOLL FREE NUMBER:

1-800-528-9131

www.liftmaster.com

For professional installation, parts and service, contact your local LIFTMASTER/CHAMBERLAIN dealer. Look for him in the Yellow Pages, or call our Service number for a list of dealers in your area.

HOW TO ORDER REPAIR PARTS

Selling prices will be furnished on request or parts will be shipped at prevailing prices and you will be billed accordingly.

WHEN ORDERING REPAIR PARTS, ALWAYS GIVE THE FOLLOWING INFORMATION:

- PART NUMBER
- PART NAME
- MODEL NUMBER

ADDRESS ORDERS TO:
THE CHAMBERLAIN GROUP, INC.
Technical Support Group
6050 S. Country Club Road
Tucson, Arizona 85706

**SERVICE INFORMATION
TOLL FREE NUMBER:
1-800-528-9131**

LIFTMASTER® FIVE YEAR LIMITED WARRANTY LIFETIME MOTOR LIMITED WARRANTY ONE YEAR LIMITED WARRANTY FOR EVERCHARGE® STANDBY POWER BATTERY

The Chamberlain Group, Inc. ("Seller") warrants to the first retail purchaser of this product, for the residence in which this product is originally installed, that it is free from defect in materials and/or workmanship for a period of 60 full months from the date of purchase and that the motor is free from defect in materials and/or workmanship for a period of the lifetime of the product. The proper operation of this product is dependent on your compliance with the instructions regarding installation, operation, and maintenance and testing. Failure to comply strictly with those instructions will void this limited warranty in its entirety.

If, during the limited warranty period, this product appears to contain a defect covered by this limited warranty, call 1-800-528-9131; toll free, before dismantling this product. Then send this product, pre-paid and insured, to our service center for warranty repair. You will be advised of shipping instructions when you call. Please include a brief description of the problem and a dated proof-of-purchase receipt with any product returned for warranty repair. Products returned to Seller for warranty repair, which upon receipt by Seller are confirmed to be defective and covered by this limited warranty, will be repaired or replaced (at Seller's sole option) at no cost to you and returned pre-paid. Defective parts will be repaired or replaced with new or factory-rebuilt parts at Seller's sole option.

ALL IMPLIED WARRANTIES FOR THE PRODUCT, INCLUDING BUT NOT LIMITED TO ANY IMPLIED WARRANTIES OF MERCHANTABILITY AND FITNESS FOR A PARTICULAR PURPOSE, ARE LIMITED IN DURATION TO THE FIVE YEAR LIMITED WARRANTY PERIOD SET FORTH ABOVE EXCEPT THE IMPLIED WARRANTIES WITH RESPECT TO THE BATTERY, WHICH IS LIMITED IN DURATION TO ONE YEAR, MOTOR, WHICH IS LIMITED IN DURATION TO THE LIFETIME LIMITED WARRANTY PERIOD FOR THE MOTOR, AND NO IMPLIED WARRANTIES WILL EXIST OR APPLY AFTER SUCH PERIOD. Some states do not allow limitations on how long an implied warranty lasts, so the above limitation may not apply to you.

THIS LIMITED WARRANTY DOES NOT COVER NON-DEFECT DAMAGE, DAMAGE CAUSED BY IMPROPER INSTALLATION, OPERATION OR CARE (INCLUDING, BUT NOT LIMITED TO ABUSE, MISUSE, FAILURE TO PROVIDE REASONABLE AND NECESSARY MAINTENANCE, UNAUTHORIZED REPAIRS OR ANY ALTERATIONS TO THIS PRODUCT), LABOR CHARGES FOR REINSTALLING A REPAIRED OR REPLACED UNIT, REPLACEMENT OF BATTERIES IN REMOTE CONTROL TRANSMITTERS AND LIGHT BULBS OR UNITS INSTALLED FOR NON-RESIDENTIAL USE. THIS LIMITED WARRANTY DOES NOT COVER ANY PROBLEMS WITH, OR RELATING TO, THE GARAGE DOOR OR GARAGE DOOR HARDWARE, INCLUDING BUT NOT LIMITED TO THE DOOR SPRINGS, DOOR ROLLERS, DOOR ALIGNMENT OR HINGES. THIS LIMITED WARRANTY ALSO DOES NOT COVER ANY PROBLEMS CAUSED BY INTERFERENCE. ANY SERVICE CALL THAT DETERMINES THE PROBLEM HAS BEEN CAUSED BY ANY OF THESE ITEMS COULD RESULT IN A FEE TO YOU. UNDER NO CIRCUMSTANCES SHALL SELLER BE LIABLE FOR CONSEQUENTIAL, INCIDENTAL OR SPECIAL DAMAGES ARISING IN CONNECTION WITH USE, OR INABILITY TO USE, THIS PRODUCT. IN NO EVENT SHALL SELLER'S LIABILITY FOR BREACH OF WARRANTY, BREACH OF CONTRACT, NEGLIGENCE OR STRICT LIABILITY EXCEED THE COST OF THE PRODUCT COVERED HEREBY. NO PERSON IS AUTHORIZED TO ASSUME FOR US ANY OTHER LIABILITY IN CONNECTION WITH THE SALE OF THIS PRODUCT.

Some states do not allow the exclusion or limitation of consequential, incidental or special damages, so the above limitation or exclusion may not apply to you. This limited warranty gives you specific legal rights, and you may also have other rights, which vary from state to state.