



Centurion Deuren B.V.

Kantoor

Koningsweg 2-13, 3762 EC Soest

Werkplaats/Showroom

Nijverheidsweg 24, 3762 ER Soest

T (035) 60 30 982

F (035) 60 31 544

E info@centuriondeuren.nl

I www.centuriondeuren.nl

IBAN NL87 RABO 0131 1795 43

KvK 32032777

BTW NL 0051621802

Gebruikers- & Installatiehandleiding KS-Serie (70 - 100)

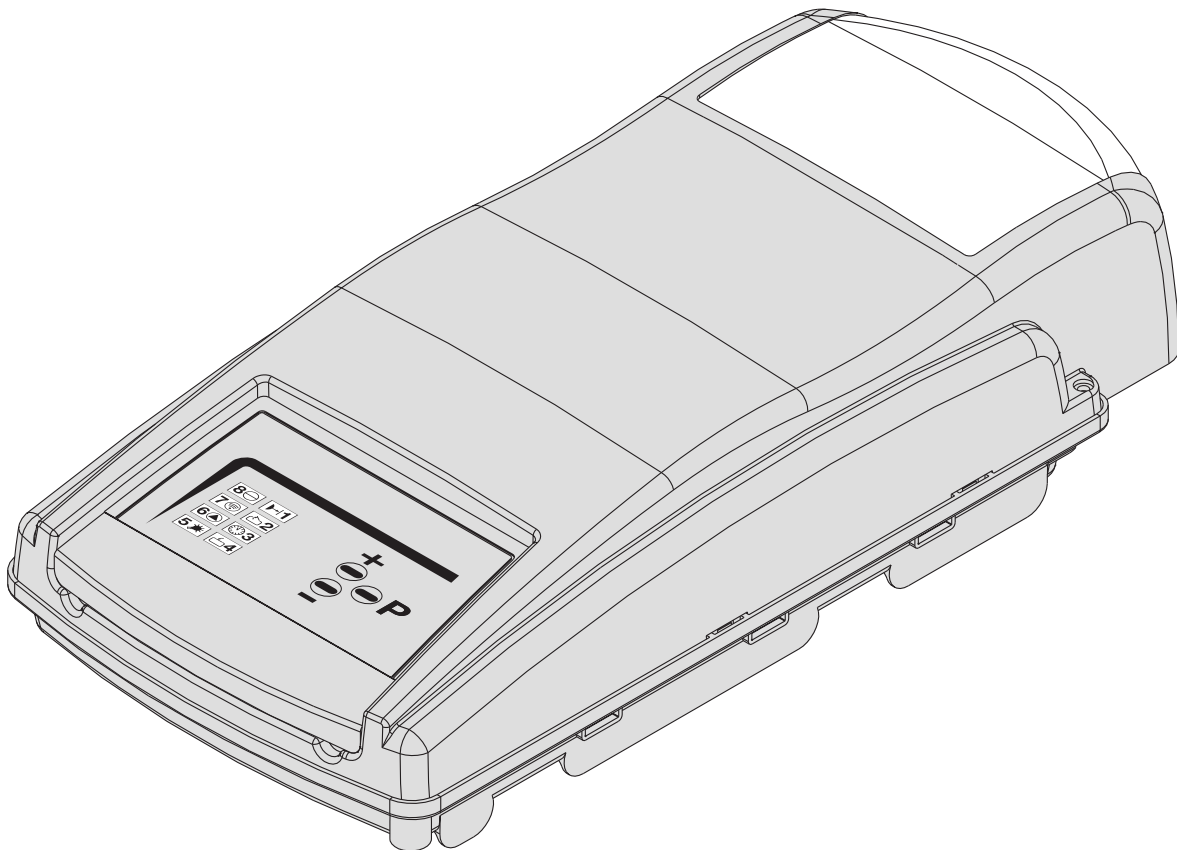

Offertes en leveringen geschieden volgens onze leveringsvoorwaarden gedeponereerd ter Griffie van de Arrondissementsrechtbank te Amsterdam.
Diverse Centurion geautomatiseerde segmentdeuren zijn getest en goedgekeurd voor gebruik bij het Politiekeurmerk Veilig Wonen®

⚠ BELANGRIJKE VEILIGHEIDSINSTRUCTIES VOOR DE INSTALLATIE
WAARSCHUWING – INCORRECTE INSTALLATIE KAN LEIDEN TOT ERNSTIG
LETSEL. VOORKOM PERSOONLIJK LETSEL EN BESCHADIGING VAN DE
APPARATUUR. LEES DEZE INSTRUCTIES AANDACHTIG DOOR VOORDAT U
DE AANDRIJVING MONTEERT.

Controleer of de garagedeur in goede staat en balans is en dat hij goed open en dicht gaat alvorens u de aandrijving installeert.

- Gebruik geen extra krachten om te compenseren voor een moeilijk lopende garagedeur. Overdadig benodigde krachten voorkomen een veilig werkende Safety Reverse Systeem of kunnen de garagedeur beschadigen.
- Kleding kan vastraken in hendels en andere uitsteeksels. Verwijder alle touwen, hendels, haken, beugels en andere uitsteeksels van de deur. Draag geen wijde losse kleding.
- Plaats het wandcontact (drukknop) in het zicht van garagedeur, maar weg van elk beweegbaar onderdeel van de garagedeur. Het is raadzaam het wandcontact hoog genoeg, buiten bereik voor kinderen, te plaatsen.
- **De Safety Reverse Systeem test is erg belangrijk.** Een dichtgaande garagedeur moet stoppen en terug opengaan indien zich er een obstakel onder de deur bevind. **Het niet correct instellen** kan resulteren in schade of letsel. Herhaal deze test maandelijks en pas, indien noodzakelijk, instellingen aan (zie Menu ④ en Menu ⑤ op blz. 12 van deze handleiding).

Plaatselijke veiligheidsvoorschriften in acht nemen. Netvoeding- en stroomleidingen absoluut gescheiden leggen.

- Indien er geen tweede toegangsdeur tot garage is, moet men een noodontgrendeling van buitenaf installeren. Deze accessoire maakt het mogelijk toegang tot garage te krijgen in geval van een stroomuitval.
- Voor het openen van de behuizing de aandrijving eerst loskoppelen van de netspanning!
- Controleer de installatie, met name de kabels, veren en bevestigingen op tekenen van slijtage, beschadiging of het niet goed in balans zijn. Breng zelf geen veranderingen aan deur, veren of kabels aan, daar een niet goed gebalanceerde deur letsel kan veroorzaken.
- Sloten of grendels op de deur verwijderen of buiten gebruik stellen.

BELANGRIJKE VEILIGHEIDSOPMERKING

Houd mensen en dieren uit de buurt van bewegende deuren. Laat iedereen zien hoe de aandrijving veilig gebruikt kan worden. Open de deur alleen als deze volledig zichtbaar is. Laat nooit iemand onder een bewegende deur doorlopen. Laat geen kinderen met de deur of afstandsbediening spelen.

VEILIGHEIDSVORZIENINGEN

- **Automatische terugloop**
Een sluitende deur stopt en opent zich automatisch binnen 2 seconden indien de deur een obstakel raakt.
- **Automatische looptijdbe grenzing**
Sluitende deur stopt en opent zich indien deze niet geheel is gesloten binnen 88 seconden (instelbaar 30 - 240 seconden).
- **Safety Stop**
Opegaande deur stopt binnen 2 seconden zodra deze tegen een obstakel komt.
- **Fotocel**
Voor extra veiligheid bevelen wij een fotocel aan. Indien een voorwerp of persoon de infra-rood straal onderbreekt terwijl de deur sluit, stopt de deur en keert deze terug in stand open zonder dat iemand de deur zelf heeft aangeraakt.

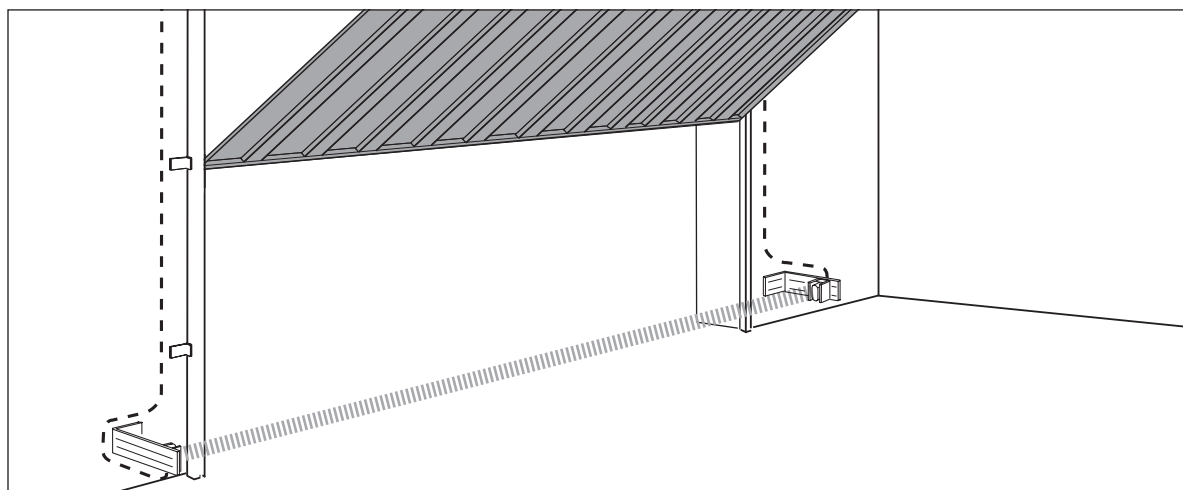

BELANGRIJK

Voor optimale veiligheid moet men de onafhankelijk open en dichtloop krachtbe grenzing (zie Menu ④ en Menu ⑤ op blz. 12 van deze handleiding) instellen en regelmatig testen.

Montage-instructies

Let op: Indien de opener is geleverd met een tweedelige rail dient men de montage-instructies, geleverd bij rail, in acht te nemen.

1 Plaats grijze tandwiel adapter op motoraandrijf.

De rail samen met de 2 klembeugels aan de aandrijving vastschroeven.
Zorg dat de schroeven goed vastgedraaid worden.

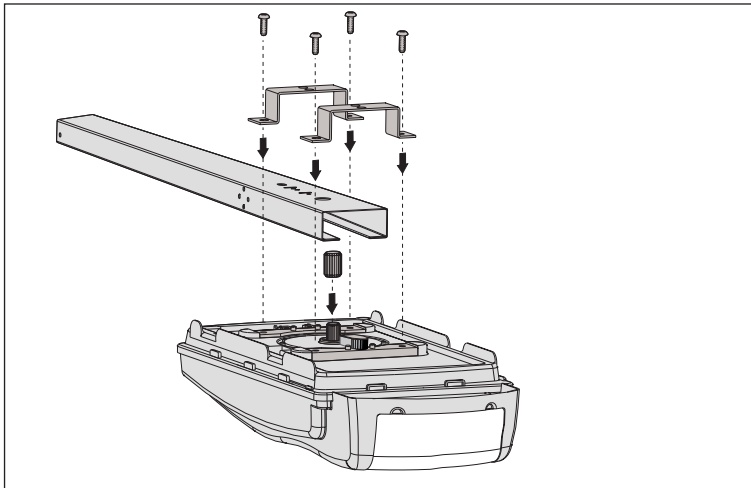

2 Monteer de inschakelpal en de trekstang op het wagentje.

- Verwijder de pal van zijn transport ligplaats en druk hem in de voorziene plaats op de loopwagen. (zie fig. 1)
- Schroef de trekstang in de loopwagen. Let op de positie van de trekkoord (zie fig. 2) om beschadiging en incorrecte werking te voorkomen

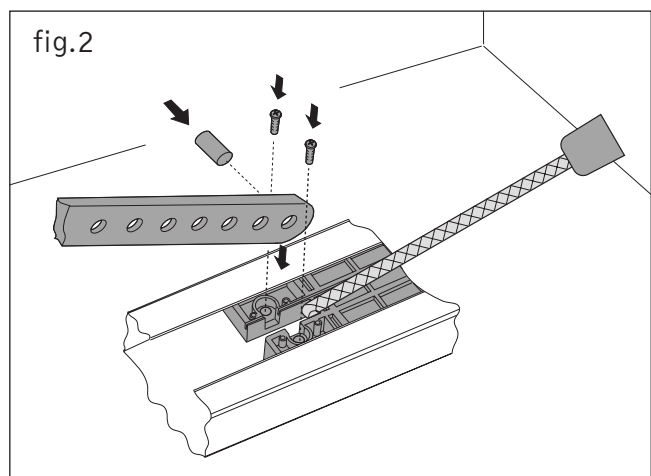
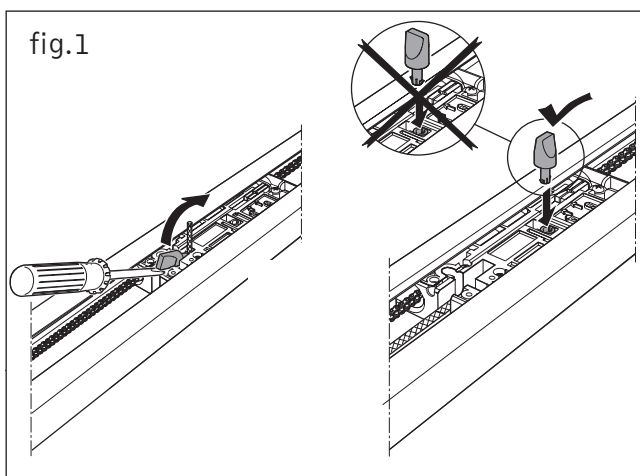

3 Snelontkoppeling.

- a. Om de loopwagen te ontgrendelen: trek aan de touw "a". De loopwagen blijft ontgrendeld.(zie fig. 3)
- b. Om de loopwagen terug in te schakelen: beweeg de rode pal in de richting van de pijl en start de opener (zie fig. 4)

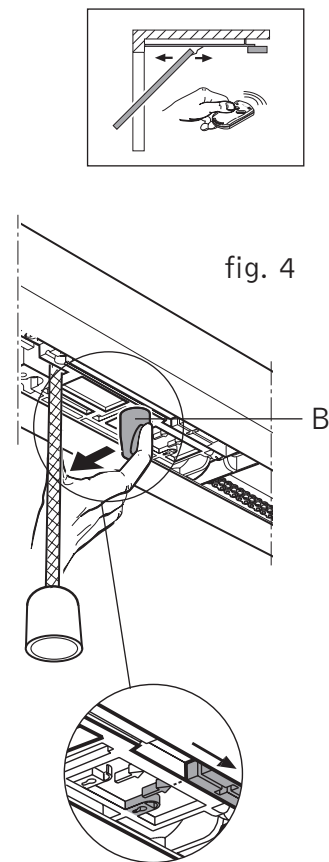
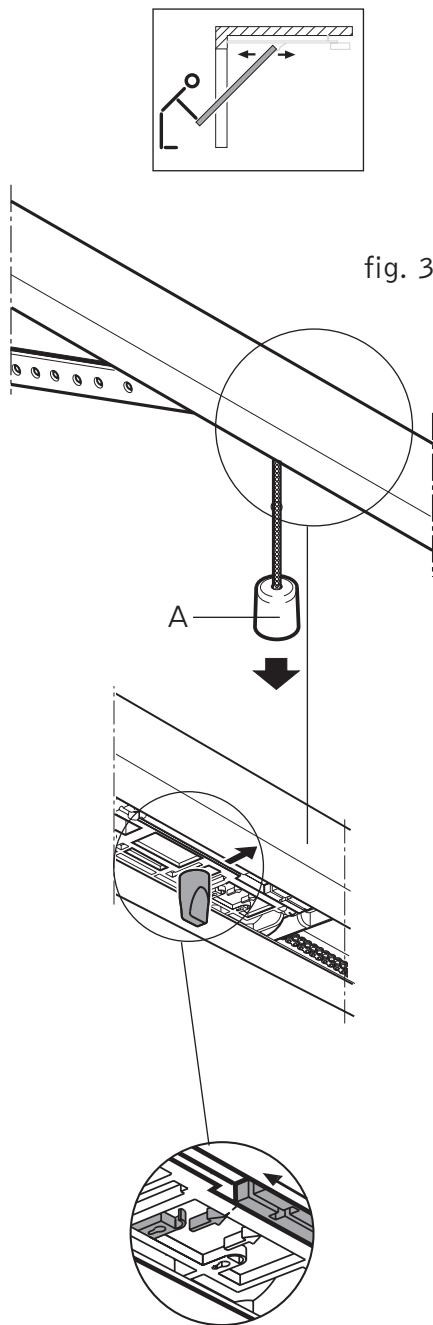

SELECTEER UW TYPE GARAGEDEUR

Voordat u de aandrijving gaat monteren dient u te controleren of de opener geschikt is voor uw type garagedeur. Bepaal uw deurtype in Stap **4A**, **4B**, **4C** of **4D** en volg nauwkeurig de individuele instructies. Voor alle overige deurtypen dient u contact op te nemen met uw leverancier. Speciale accessoires of aanpassingen kunnen noodzakelijk zijn.

4A Kanteldeuren

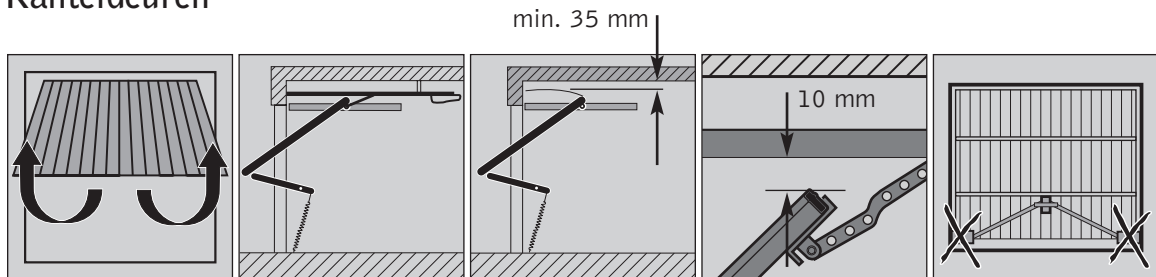

- Monteer deurbeugel in het midden van deur. Rail bevestigingsbeugel met rail in het midden boven de deur op het deurkozijn of op de latei zodanig bevestigen dat de bovenkant van het deurblad 10 mm onder de rail ligt, gemeten vanaf het hoogste punt.

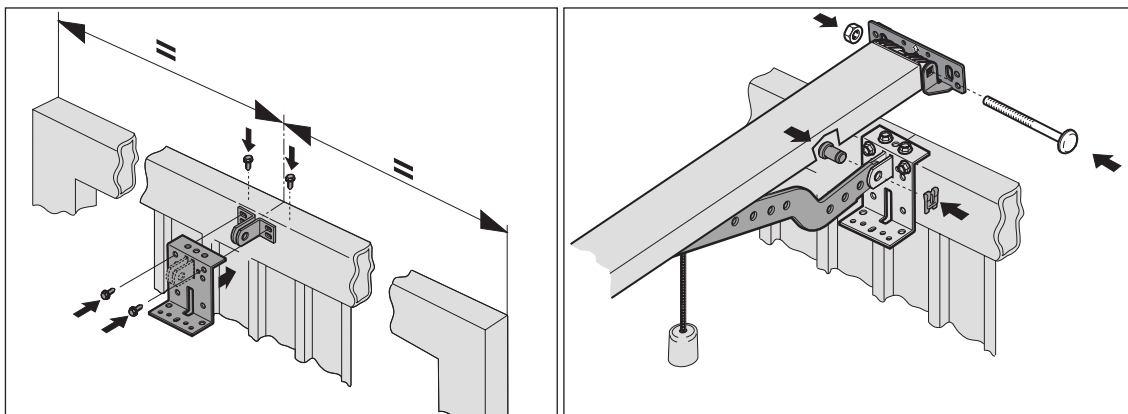

- De aandrijving met behulp van een ondersteuning horizontaal stellen en bevestigen.

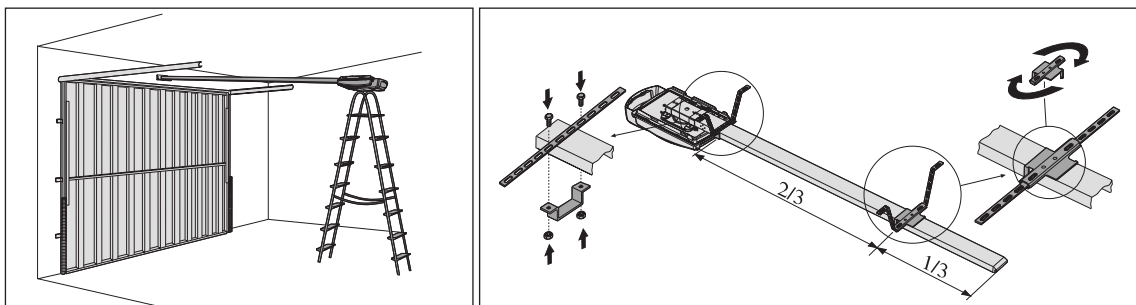

- Ontkoppel loopwagen van ketting of tandriem. Open of sluit de deur langzaam.
- Trekstang aan deurbeugel koppelen.

Let op! Sloten of grendels op de deur verwijderen of buiten gebruik stellen.

4B

Sectionaaldeuren

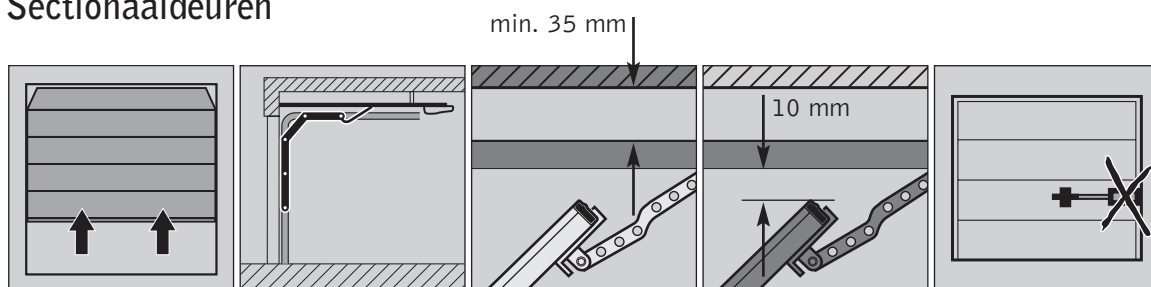

ATTENTIE

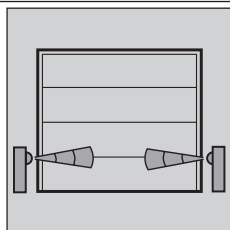

Een fotocel wordt ten zeerste aanbevolen (niet inbegrepen, apart te bestellen).

- De verstelbare console op de juiste hoogte afstellen en in het midden van het bovenste deurpaneel vastschroeven.

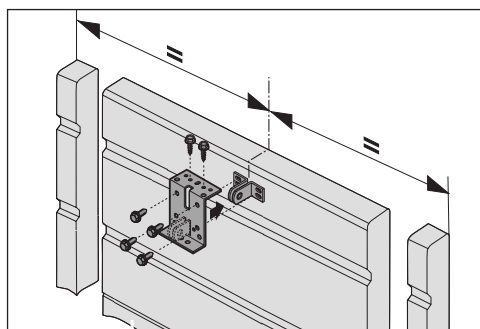

- Rail bevestigingsbeugel met rail in het midden boven de deur op het deurkozijn of op de latei zodanig bevestigen dat de bovenkant van het deurblad 10 mm onder de rail ligt, gemeten vanaf het hoogste punt.

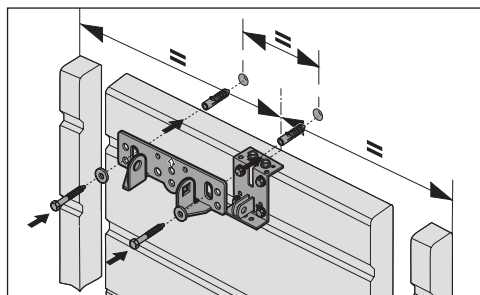

- De aandrijving met behulp van een ondersteuning horizontaal stellen en bevestigen.

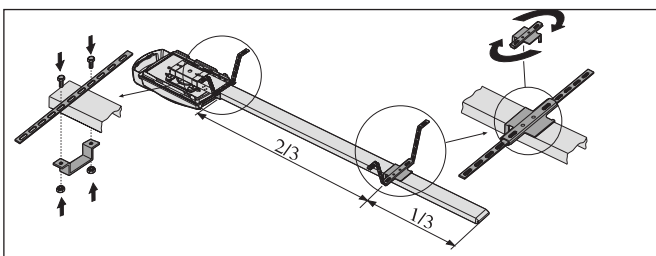
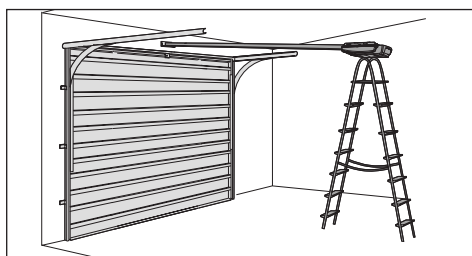

- Ontkoppel loopwagen van ketting of tandriem. Open of sluit de deur langzaam.
- Tweedelige trekstang aan deurbeugel koppelen.

Let op! sloten of grendels op de deur verwijderen of buiten gebruik stellen.

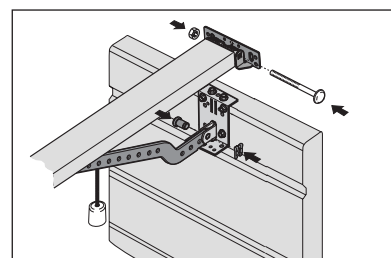

4C Binnen de gevel draaiende kanteldeur

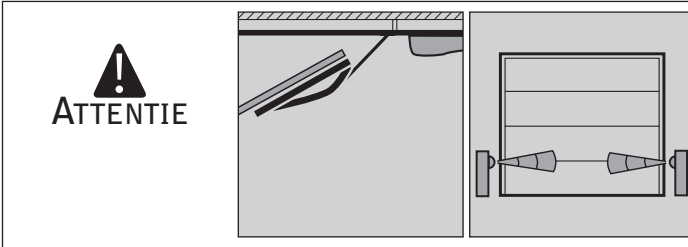
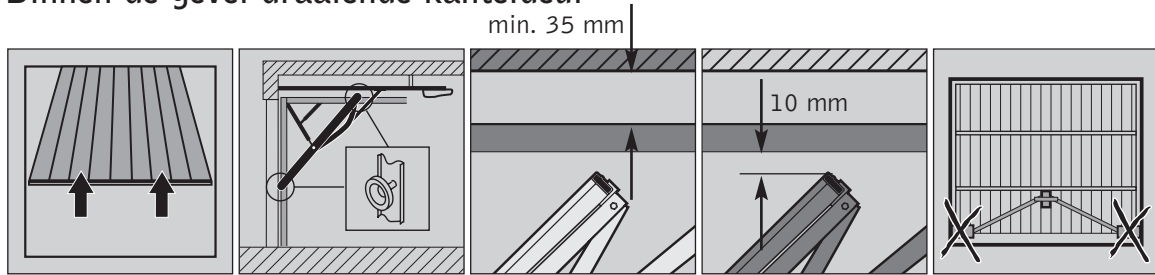

Speciale curvenarm (zie tekening) is noodzakelijk (niet inbegrepen). Een fotocel wordt ten zeerste aanbevolen (niet inbegrepen, apart te bestellen).

- Rail bevestigingsbeugel met rail in het midden boven de deur op het deurkozijn of op de latei zodanig bevestigen dat de bovenkant van het deurblad 10 mm onder de rail ligt, gemeten vanaf het hoogste punt.

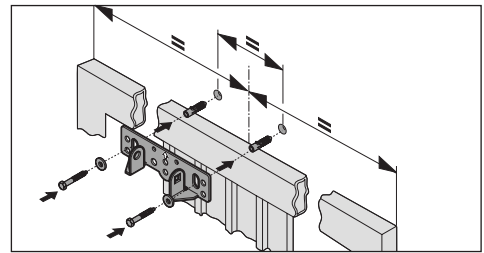

- Monteer de curvenarm volgens de instructies van de leverancier van de arm.
- De aandrijving met behulp van een onder-steuning horizontaal stellen en bevestigen.

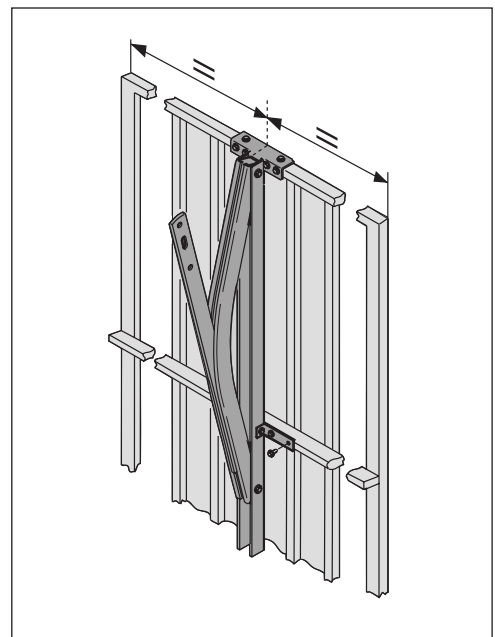
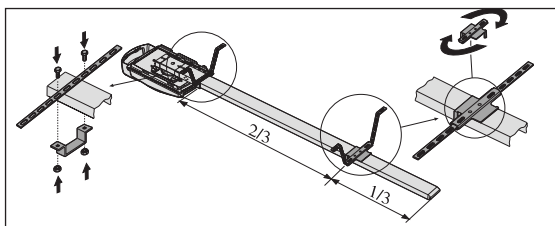
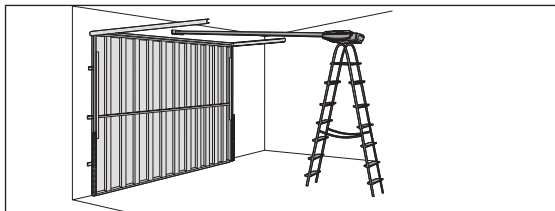

- Ontkoppel loopwagen van ketting of tandriem. Open of sluit de deur langzaam.
- De deur geheel openen en trekstang met curvenarm verbinden. Sluit deur handmatig en controleer of de afstand tussen loopwagen en deur min. 165 mm is.

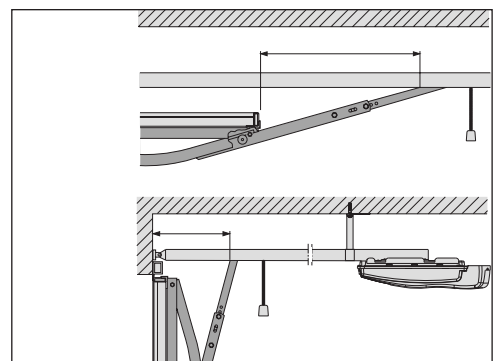

4D**Verticaal geleide deur**

(waarvan de helft buiten de gevel blijft)

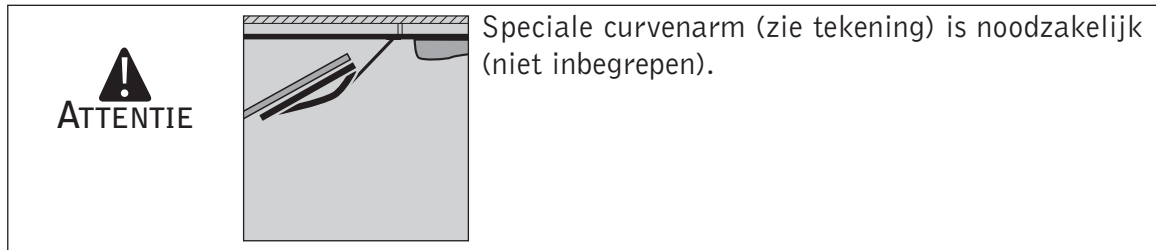
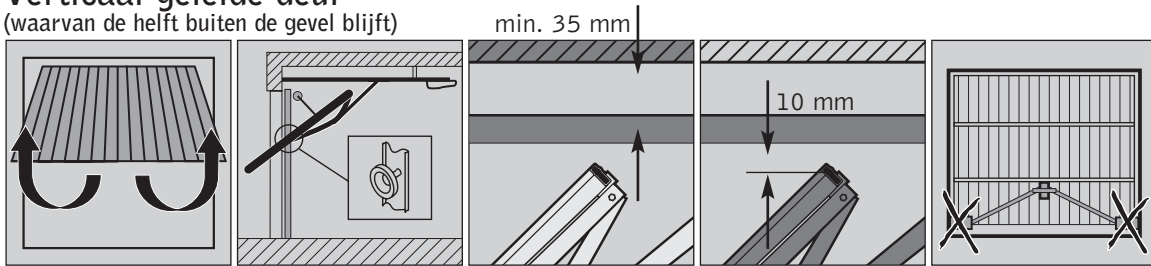

- Rail bevestigingsbeugel met rail in het midden boven de deur op het deurkozijn of op de latei zodanig bevestigen dat de bovenkant van het deurblad 10 mm onder de rail ligt, gemeten vanaf het hoogste punt.
- Monteer de curvenarm volgens de instructies van de leverancier van de arm.
- De aandrijving met behulp van een ondersteuning horizontaal stellen en bevestigen.

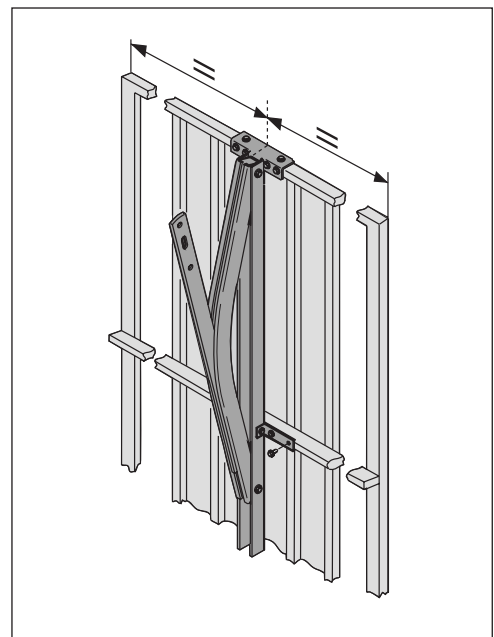
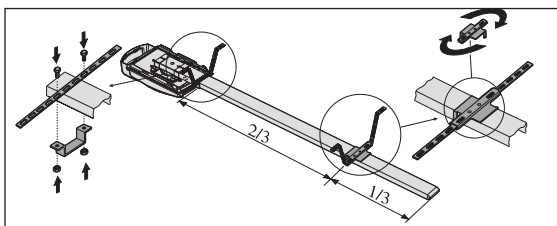
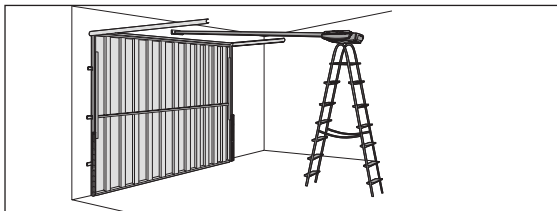
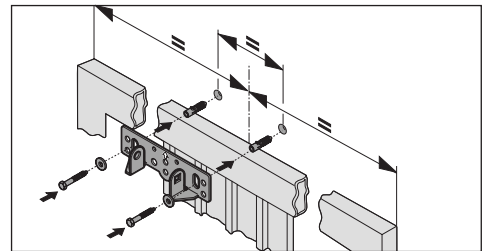

- Ontkoppel loopwagen van ketting of tandriem. Open of sluit de deur langzaam.
- De deur geheel openen en trekstang met curvenarm verbinden. Sluit deur handmatig en controleer of de afstand tussen loopwagen en deur min. 165 mm is.

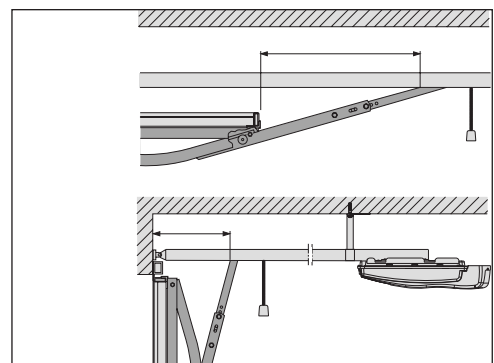









VOOR ALLE OVERIGE DEURTYPEN DIENT U CONTACT OP TE NEMEN MET UW LEVERANCIER!

- 5 Controleer of aandrijving en rail goed is geplaatst en alle schroeven zijn aangedraaid. ⚠️ Let op: voordat u uw aandrijving gaat programmeren moet uw loopwagen vergrendeld zijn (aan ketting/tandriem) en trekarm aan garagedeur bevestigd zijn.
- 6 Plaats gloeilamp.
Type E14, max. 40 Watt (niet inbegrepen).



Aanduidingen elektronisch controlepaneel

Uw aandrijving heeft een makkelijk controlepaneel met 8 verlichte symbolen en 3 programmeertoetsen.





LED's

-  1 externe fotocel
-  2 deur open
-  3 automatisch sluiten
-  4 deur gesloten
-  5 230V verlichting
-  6 storing
-  7 impuls (knippert langzaam indien 'vakantieslot')
-  8 in bedrijf, netspanning (230V)

Programmeertoetsen

-  Programmeertoets voor "verminderen" en deur DICHT testtoets
-  Programmeertoets voor "vermeerderen" en deur OPEN testtoets
-  Programmeertoets

VERKLARING

LED uit bijv. 
LED verlicht bijv. 
LED knippert bijv. 
LED knippert snel bijv. 

Standaard instelling: bijv.





Toets ingedrukt  of  of 



Verlichting van aandrijving aan:  uit: 
Externe verlichting aan:  uit: 

Programmeren van besturing - Basisfuncties

Nadat aandrijving op netstroom is aangesloten ondergaat hij automatisch een self-test; alle 8 LED's en de gloeilamp zijn voor ongeveer 2 seconden verlicht. De aandrijving is in bedrijfs-toestand nadat de gloeilamp uit is en LED  is verlicht.

HET MAKEN EN VERANDEREN VAN INSTELLINGEN:

Alle gegevens en veranderingen worden geprogrammeerd met behulp van drie programmeer-toetsen. Druk toets  voor ca. 2 sec. in om van bedrijfstoestand naar programmeermode te gaan. Laat toets  los wanneer alle LED's branden en LED  knippert. U bent nu in de programmeermode van de basis functies.

Gebruik de  en  toets voor veranderingen in programmeermenu
 toets om menukeuze / programmering op te slaan in geheugen.

MENU OVERZICHT:

- ① Programmering van de fotocel
- ② Programmering van deur OPEN eindpositie
- ③ Programmering van deur DICHT eindpositie
- ④ Programmering maximale trekkracht
- ⑤ Programmering maximale duwkracht
- ⑥ Programmering van handzender privé code

INSTELLEN VAN DE AANDRIJVING:





Menu ①

PROGRAMMEREN VAN DE FOTOCEL*

1.  toets voor ca. 2 sec indrukken (LED  knippert en alle anderen zijn verlicht).
2. A. Druk op  als u een fotocel installeert (LED  verlicht).
B. Druk op  als u geen fotocel installeert (LED  knippert snel).
3. Druk op  om fotocel functie op te slaan en automatisch naar programmeermenu ② te gaan.
*De fotocel is een optionele accessoire.





Menu ②

PROGRAMMEREN VAN DE DEUR OPEN EINDPOSITIE

1. LED  knippert en alle zijn verlicht.
2. Druk op de  toets om garagedeur naar gewenste deur OPEN eindpositie te laten gaan. Gebruik de  (OPEN) en  (DICHT) toetsen voor fijnafstelling.
3. Druk op  om deur open eindpositie op te slaan en automatisch naar programmeermenu ③ te gaan.

Menu ③

PROGRAMMEREN VAN DE DEUR DICHT EINDPOSITIE

1. LED  knippert en alle anderen zijn verlicht.
2. Druk op de  toets om garagedeur naar gewenste deur DICHT eindpositie te laten gaan. Gebruik de  (DICHT) and  (OPEN) toetsen voor fijnafstelling.
3. Druk op  om deur DICHT eindpositie op te slaan en automatisch naar programmeermenu ④ te gaan.

Externe aansluitingen

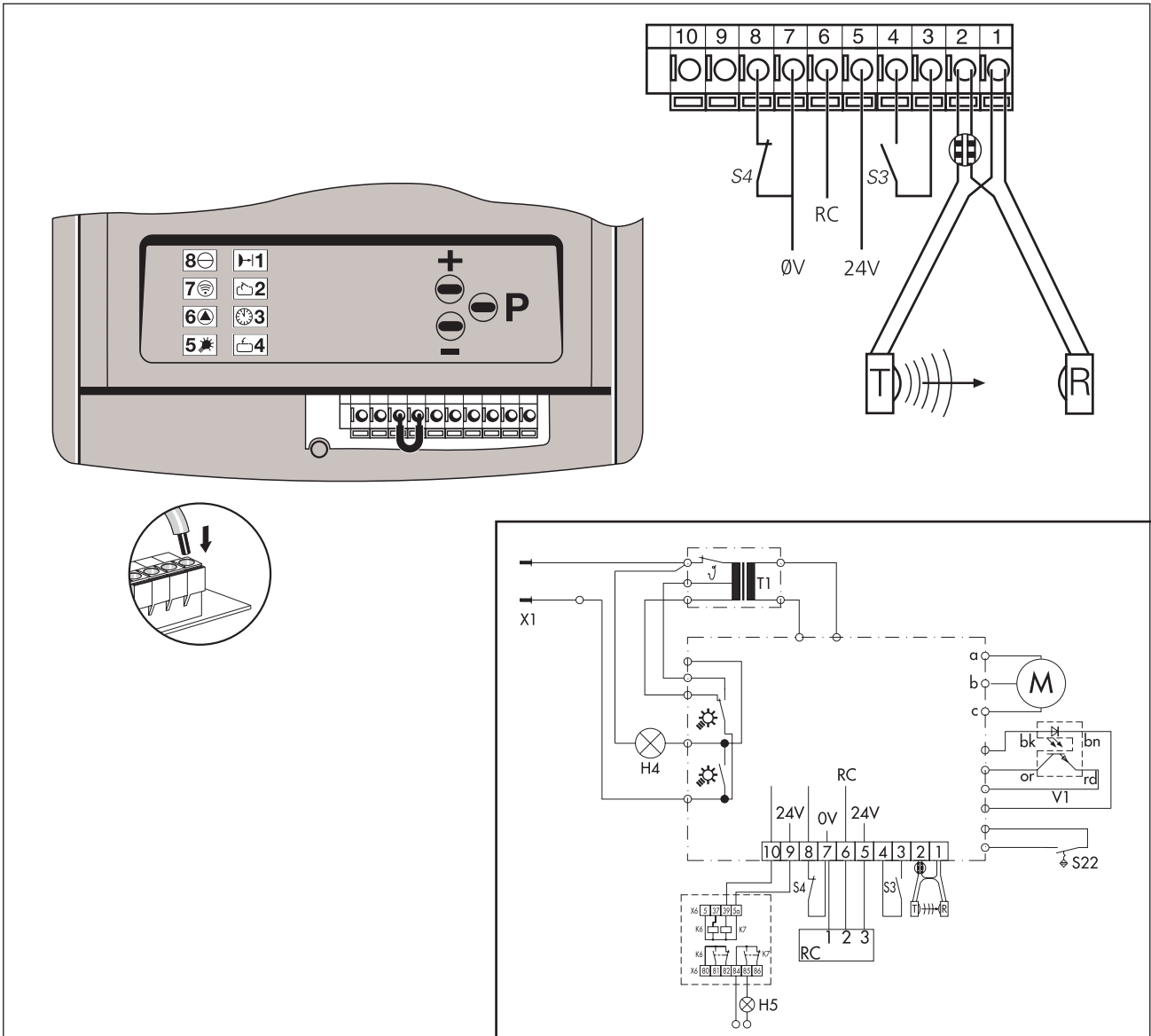

M	motor
T1	transformator
V1	toerentalsensor (RPM)
S22	referentiepuntschakelaar
T	fotocel zender
R	fotocel ontvanger
S3	drukknop IMPULSE (NO contact)
S4	drukknop (NC contact)
X1	plug 1~N 220-240V 50Hz
H4	gloeilamp
H5	signaallamp
RC	Relais contact
0V	Massa
24V	24 VDC, 50mA max.

bk	zwart
bn	bruin
or	oranje
rd	rood
a	bruin
b	groen/geel
c	groen

Het is mogelijk ofwel een druktoets ofwel een 3-voudige wandconsole aan te sluiten (impuls, licht aan/uit, vakantievergrendeling). Als LED 8 brandt en LED 7 knippert is de vakantievergrendeling geactiveerd. Deactiveer de vakantievergrendeling via 3-voudige wandconsole of het kort indrukken van de toets op de aandrijving.

Storingshandleiding

Storingsindicatie	Oorzaak	Werkwijze
LED 8 brandt niet.	Spanning ontbreekt.	Controleer of netspanning aanwezig is. Wandcontactdoos controleren.
	Thermische beveiliging transformator is in werking getreden.	Transformator laten afkoelen.
	Besturingseenheid defect.	Netspanning uitschakelen. Besturingseenheid eraf schroeven en laten controleren.
LED 6 knippert Foutmelding 10	Uitschakelautomaat te gevoelig. Deur loopt te zwaar of is geblokkeerd.	Uitschakelautomaat opnieuw instellen (Menu 4, Menu 5). Deur gangbaar maken.
LED 6 knippert Foutmelding 6 of 15	Externe fotocel defect of onderbroken.	Verwijder belemmering of fotocel laten controleren.
Aandrijving loopt alleen in "OPEN", echter niet in "DICHT" richting. Foutmelding 15	Fotocel Menu 1 geprogrammeerd, echter niet aangesloten	Fotocel omprogrammeren of aansluiten.
Geen reactie na impuls. LED 7 brandt.	Aansluitklemmen voor drukknop "IMPULSE" zijn door bijv. kortsluiting in de leiding of verkeerde aansluiting aan de klemmen gebrugd.	Alle contactschakelaars van de aandrijving loskoppelen. Eén voor één opnieuw aansluiten en fout zoeken.
Geen reactie na impuls. Foutmelding 36	Kortsluitstekker S4 (NC) verwijderd, zonder STOP-knop te hebben aangesloten.	Stop-drukknop aansluiten.
Indien interne ontvanger: LED 7 knippert niet snel na impuls via handzender.	Codering van de handzender komt niet overeen met ontvangercodering.	Codering controleren Menu 6.
	Batterij leeg.	Nieuwe 12V A 23 batterij plaatsen. De knipperdiode van de zender geeft de conditie van de batterij aan.
	Handzender, besturingselektronica of antenne defect.	Controleer alle drie de componenten.
Onvoldoende reikwijdte van de afstandsbediening (minder dan 5 m).	Batterij leeg.	Nieuwe 12V A 23 batterij plaatsen. De knipperdiode van de zender geeft de conditie van de batterij aan.
LED 6 knippert. Foutmelding 9	Toerentalsensor.	Aandrijving laten nakijken.
	Deur loopt te zwaar.	Deur laten nakijken.
Reageert niet op zender maar wel op drukknop LED 8 brandt LED 7 knippert	Aandrijving is in vakantie-vergrendeling	Deactiveer de vakantievergrendeling via 3-voudige wandconsole of het kort indrukken van de  toets op de aandrijving.

DIAGNOSE WORDT ZICHTBAAR INDIEN DE  TOETS KORT WORDT INGEDRUKT.

LED knippert onregelmatig







 + 

 + 

 + 

 + 

 +  + 

 +  +  +  + 

 +  +  +  + 

 +  +  +  +  +  +  + 

Foutmelding

6	Fotocel aangesproken
7	Programmering afgebroken
8	Referentiepuntschakelaar defect
9	Toerentalsensor defect Blokkeerbeveiliging aangesproken
10	Krachtbegrenzing
11	Looptijdbegrenzing
15	Test fotocel niet o.k.
16	Test krachtbegrenzing
28	Zelflerende krachtbegrenzing
27	'Offset' gevoeligheid krachtbegrenzing
36	Ruststroomcircuit onderbroken

Storingsindicatie

Programmeren van de besturing - Geavanceerde instellingen

Waarschuwing – Het programmeren van de geavanceerde instellingen mag alleen door een getraind en bevoegd vakman worden uitgevoerd.

GEAVANCEERDE PROGRAMMEER EN UITBREIDINGSMOGELIJKHEDEN:

- Automatisch sluiten (Niveau 3).
- Aanpassen Automatische krachtinstellingen en verlichting (Niveau 4).
- Verlichting / signaallampen (Niveau 5).

Programmeren van de besturing - Automatisch sluiten (Niveau 3)

Waarschuwing – Bij activering van de functie automatisch sluiten moet een fotocel aangesloten worden overeenkomstig Menu ① in de basisfuncties.

MENU OVERZICHT (N3):

- ① Tijdsduur 'deur open' (automatisch sluiten).
- ② Programmeren voorwaarschuwingstijd (tijd voordat de deur sluit).
- ③ Programmeren voorwaarschuwingstijd voordat de deur opengaat
(te gebruiken in combi met waarschuwingslamp).
- ④ Voortijdig sluiten na het passeren van de fotocel.
- ⑤ Reset van de niveau 3 menu's

PROGRAMMEREN AUTOMATISCH SLUITEN:

Menu ① (N3)

TIJDSDUUR 'DEUR OPEN' (AUTOMATISCH SLUITEN)

Besturing bevindt zich in bedrijfstoestand.

1. Programmeertoetsen , en tegelijk ca. 10 seconden indrukken totdat LED knippert en alle andere zijn verlicht.
2. Laat los (LED knippert).
3. Gebruik de en toetsen om 'deur open' tijdsduur te programmeren.
minimale tijd: 5 seconden
maximale tijd: 255 seconden



timer	5	10	15	20	25	30	35	40	50	80	100	120	150	180	255	
deactivated	seconds	seconds	seconds	seconds	seconds	seconds	seconds	seconds	seconds	seconds	seconds	seconds	seconds	seconds	seconds	seconds

































4. Druk op om 'deur open' tijdsduur op te slaan en automatisch naar Menu ② te gaan.

Menu 2 (N3)

PROGRAMMEREN VOORWAARSCHUWINGSTIJD (TIJD VOORDAT DEUR SLUIT)

Nadat de 'deur open' tijdsduur is geprogrammeerd knippert LED .



- Controleer of LED  knippert en dat alle andere zijn verlicht.
- Gebruik de  en  toetsen om 'voorwaarschuwingstijd' te programmeren.
minimale tijd: 2 seconden
maximale tijd: 70 seconden





























 	 	 	 	 	 	 	 	 	 	 	 	 	 	 	 
timer activated	2 seconds	5 seconds	10 seconds	15 seconds	20 seconds	25 seconds	30 seconds	35 seconds	40 seconds	45 seconds	50 seconds	55 seconds	60 seconds	65 seconds	70 seconds

- Druk op  om op te slaan en naar Menu 3 te gaan.

Menu 3 (N3)

PROGRAMMEREN VOORWAARSCHUWINGSTIJD VOORDAT DE DEUR OPENGAAT





- Controleer of LED  knippert en dat alle andere zijn verlicht.
- Gebruik de  en  toetsen om 'voorwaarschuwingstijd' te programmeren.
minimale tijd: 0 seconden
maximale tijd: 7 seconden

 	 	 	 	 	 	 	 	 	 	 	 	 	 
0 seconds	1 seconds	2 seconds	3 seconds	4 seconds	5 seconds	6 seconds	7 seconds						

- Druk op  om op te slaan en naar Menu 4 te gaan.





Menu 4 (N3)

VOORTIJDIG SLUITEN NA HET PASSEREN VAN DE FOTOCEL

- Controleer of LED  knippert en dat alle andere zijn verlicht.
- Gebruik de  en  toetsen om de gewenste instelling te kiezen:
 - LED  knippert: Deur sluit na de ingestelde tijd
 - LED  brandt: Deur sluit na het passeren van de fotocel

 	 	 	 	 	 	 	 	 	 	 	 	 	 
 	 	 	 	 	 	 	 	 	 	 	 	 	 
 	 	 	 	 	 	 	 	 	 	 	 	 	 
 	 	 	 	 	 	 	 	 	 	 	 	 	 
Deur sluit na de ingestelde tijd	Deur sluit na de ingestelde tijd	Deur sluit na de ingestelde tijd	Deur sluit na de ingestelde tijd	Deur sluit na de ingestelde tijd	Deur sluit na de ingestelde tijd	Deur sluit na de ingestelde tijd	Deur sluit na de ingestelde tijd	Deur sluit na de ingestelde tijd	Deur sluit na de ingestelde tijd	Deur sluit na de ingestelde tijd	Deur sluit na de ingestelde tijd	Deur sluit na de ingestelde tijd	Deur sluit na de ingestelde tijd
													Deur sluit na het passeren van de fotocel

- Druk op  om op te slaan en om het geavanceerde programmeerniveau 3 "Automatisch sluiten" te beëindigen.

Alle LED's gaan in volgorde van  tot  uit. De aandrijving is nu in bedrijfstoestand; LED  en mogelijk LED  (deur volledig open) of LED  (deur volledig gesloten) zijn verlicht.

Menu 5 (N3)

RESET VAN DE NIVEAU 3 MENU'S:

Druk de programmeertoetsen en tegelijk in voor langer dan 20 seconden.

De reset is uitgevoerd wanneer de LED's automatisch uitschakelen beginnende met LED en eindigend met LED .

De aandrijving is nu terug in bedrijfstoestand; LED en mogelijk LED (deur volledig open) of LED (deur volledig gesloten) zijn verlicht.

Programmeren automatische krachtinstellingen en verlichting (Niveau 4)

Waarschuwing – Het programmeren van de geavanceerde instellingen mag alleen door een getraind en bevoegd vakman worden uitgevoerd.

MENU OVERZICHT (N4):

- 1 Programmeren tijdsduur verlichting
- 2 Programmeren 'meerwaarde' automatisch geleerde kracht
- 3 Programmeren van 'meerwaarde' automatisch geleerde kracht in langzame snelheid

HET AANPASSEN VAN DE AUTOMATISCHE KRACHTINSTELLINGEN EN VERLICHTING:

1. Druk in de bedrijfstoestand tegelijk ca. 10 seconden op , en totdat LED knippert en alle andere LED's zijn verlicht.
2. Blijf op drukken en selecteer met de of toets Niveau 4 (LED knippert snel).
3. Laat los.

Menu 1 (N4)

PROGRAMMEREN TIJDSDUUR VERLICHTING ()

1. LED knippert en alle andere zijn verlicht.
2. Gebruik de of toetsen om verlichtingsduur te programmeren.
minimale tijd: 90 seconden
maximale tijd: 240 seconden

90	95	100	110	120	130	140	150	160	170	180	190	200	210	220	240	
seconds	seconds	seconds	seconds	seconds	seconds	seconds	seconds	seconds	seconds	seconds	seconds	seconds	seconds	seconds	seconds	seconds

3. Druk op om op te slaan en automatisch naar Menu 2 te gaan.

Menu 2 (N4)

PROGRAMMEREN 'MEERWAARDE' AUTOMATISCH GELEERDE KRACHT



1. LED knippert en alle andere zijn verlicht.
2. Gebruik de of toetsen om 'meerwaarde' in stappen van 1/15 te verhogen of te verminderen.
minimale meerwaarde: 1/15
maximale meerwaarde: 15/15

deakti- vated	1/15	2/15	3/15	4/15	5/15	6/15	7/15	8/15	9/15	10/15	11/15	12/15	13/15	14/15	15/15	



















































































































3. Druk op om op te slaan en automatisch naar Menu 3 te gaan.

Menu 3 (N4)





PROGRAMMEREN VAN 'MEERWAARDE' AUTOMATISCH GELEERDE KRACHT IN LANGZAME SNELHEID

- LED  knippert en alle andere zijn verlicht.
- Gebruik de  of  toetsen om 'meerwaarde' automatisch geleerde kracht in langzame snelheid in stappen van 1/15 te verhogen of te verminderen.

minimale meerwaarde: 1/15
maximale meerwaarde: 15/15

 	 	 	 	 	 	 	 	 	 	 	 	 	 	 	 	 	 	 	
 	 	 	 	 	 	 	 	 	 	 	 	 	 	 	 	 	 	 	
 	 	 	 	 	 	 	 	 	 	 	 	 	 	 	 	 	 	 	
deakti- vated	1/15	2/15	3/15	4/15	5/15	6/15	7/15	8/15	9/15	10/15	11/15	12/15	13/15	14/15	15/15				

- Druk op  om op te slaan en om het geavanceerde programmeerniveau 4 "Automatische krachtinstellingen en verlichting" te beëindigen.

Alle LED's gaan in volgorde van  tot  uit. De aandrijving is nu in bedrijfstoestand; LED  en mogelijk LED  (deur volledig open) of LED  (deur volledig gesloten) zijn verlicht.









Programmeren van verlichting / signaallampen (Niveau 5)

Waarschuwing - Het programmeren van de geavanceerde instellingen mag alleen door een getraind en bevoegd vakman worden uitgevoerd.

MENU OVERZICHT (N5):



- Programmeren van looptijdbegrenzing
- Programmeren van externe signaal lampen
- Programmeren van verlichting van de aandrijving
- Programmeren verlichting 'externe lichtrelais' (box) en van de aandrijving















































































HET AANPASSEN VAN DE VERLICHTING EN/OF SIGNAALLAMPEN:

- Druk in de bedrijfstoestand tegelijk ca. 10 seconden op ,  en  totdat LED  knippert en alle andere LED's zijn verlicht.
- Blijf op  drukken en selecteer met de  of  toets Niveau 5 (LED  knippert snel)
- Laat  los.

Menu 1 (N5)

PROGRAMMEREN VAN LOOPTIJD BEGRENZING (MAXIMALE DUUR VAN SLUITEN)





- LED  knippert en alle andere zijn verlicht.
- Gebruik de  en  toetsen om verlichtingsduur te programmeren
minimale tijd: 30 seconden
maximale tijd: 240 seconden









 	 	 	 	 	 	 	 	 	 	 	 	 	 	 	 	 	 	 	
																			
																			
30	40	50	55	65	80	100	120	140	160	180	190	200	210	220	240				
seconds	seconds	seconds	seconds	seconds	seconds	seconds	seconds	seconds	seconds	seconds	seconds	seconds	seconds	seconds	seconds				

- Druk op  om op te slaan en automatisch naar Menu  te gaan.

Menu ② (N5)

PROGRAMMEREN VAN EXTERNE SIGNAALLAMPEN (☀/🔦)





1. LED  knippert en alle andere zijn verlicht.
2. Gebruik de  en  toetsen voor het programmeren van verlichting
LED  knippert externe lampen branden
LED  brandt externe lampen knipperen









    externe lampen branden	    externe lampen knipperen
--	--

3. Druk op  om op te slaan en automatisch naar Menu ③ te gaan.

Menu ③ (N5)

PROGRAMMEREN VAN VERLICHTING VAN DE AANDRIJVING (💡/💡)





1. LED  knippert en alle andere zijn verlicht.
2. Gebruik de  en  toetsen voor het programmeren van verlichting
LED  knippert verlichting brandt tijdens voorwaarschuwingstijd (sluiten)
LED  brandt verlichting knippert tijdens voorwaarschuwingstijd (sluiten)

    verlichting brandt tijdens waarschuwingstijd	    verlichting knippert tijdens waarschuwingstijd
---	---

3. Druk op  om op te slaan en automatisch naar Menu ④ te gaan.





Menu ④ (N5)

PROGRAMMEREN VERLICHTING 'EXTERNE LICHTRELAIS' (BOX) EN VAN DE AANDRIJVING

1. LED  knippert en alle andere zijn verlicht.
2. Gebruik de  en  toetsen voor het programmeren van verlichting
LED  knippert aandrijvingverlichting brandt tijdens waarschuwingstijd
LED  brandt extern lichtrelais 30 sec. alarmmelding na het aanspreken van de beveiliging tegen ongewenst openen.

    aandrijvingverlichting brandt tijdens waarschuwingstijd	    extern lichtrelais 30 sec. alarmmelding na het aanspreken van de beveiliging tegen ongewenst openen.
---	--

3. Druk op  om op te slaan en om het geavanceerde programmeerniveau 5 " Programmeren van Verlichting / signaallampen " te beëindigen.

Alle LED's gaan in volgorde van LED  tot LED  uit. De aandrijving is nu in bedrijfs-toestand; LED  en mogelijk LED  (deur volledig open) of LED  (deur volledig gesloten) zijn verlicht.

Technische gegevens:

Centurion KS70 / KS100
Garagedeuropener

Aansluiting

230 V
250 W (in bedrijf met verlichting)
3,9 W (stilstand zonder verlichting)

Bewegingssnelheid:

0,14 cm/sec. met vertraagde start en stop

Trek- en duwkracht:

KS70 = 700 N
KS100 = 1000 N

Looptijdbegrenzing:

88 sec. (instelbaar)

Verlichting:

1 x 40 W (type E14), instelbaar van
90 - 240 sec.

Stuurspanning:

Laagspanning minder dan 24 V DC

Automatische sluiten:

Voor het automatisch sluiten van garagedeur zijn de optionele fotocellen noodzakelijk. Waarschuwingstijd instelbaar van 2 tot 70 sec. en openingstijd van 5 - 255 sec. Voor aansluiting signaallampen is een extern lichtrelais als toebehoren verkrijgbaar.

Uitschakelautomaat:

Elektronische krachtbegrenzing door micro-processor en stroomsensor.

Blokkeerbeveiliging:

Door microprocessor en toerentalsensor.

Inbraak beveiligingssysteem:

Elektronische back-drive beveiliging bij gesloten deur; deur sluit zich automatisch na detectie van een circa 1cm. ongewenste (terugwaartse) beweging.

Beschermingsgraad:

Uitsluitend geschikt voor droge ruimtes..

⚠ Let op: Plaatselijke veiligheidsvoorschriften in acht nemen!
Netvoeding- en stroomleidingen absoluut gescheiden leggen.

⚠ Let op: Open en sluit de deur alleen als deze volledig zichtbaar is en wanneer u er zeker van bent dat er geen personen of objecten in het looptraject van garagedeur bevinden.

Onderhoud

Deze garagedeuropener is grotendeels onderhoudsvrij. Echter, alle bewegende delen van de deur en de aandrijving dienen regelmatig gecontroleerd en goed afgesteld te worden. De deur moet gemakkelijk met de hand bediend kunnen worden; controleer regelmatig en handmatig of de deur goed is uitgebalanceerd. De instelling van uitschakelautomaat OPEN en DICHT dienen regelmatig getest te worden.

Manufacturers Declaration

We hereby declare that the product referred to below, with reference to its design, construction and to the version as marketed by us, conforms to the relevant safety and health requirements contained in the European Council Directives pertaining to electromagnetic compatibility, machines and low voltage.

This declaration becomes null and void in the event of modification or changes to the product not expressly agreed with us.

KS-series

Relevant European Council Directives pertaining to electromagnetic compatibility (89/336/EEC, 93/68/EEC and 93/44/EEC), machines (89/392/EEC, 91/368/EEC, 93/68/EEC and 93/44/EEC) and low voltage (73/23/EEC, 93/68/EEC and 93/44/EEC).

To agreed standards: EN55014
EN60555-2
EN60555-3
EN40082-1
EN60335-1

To National standard and technical specification:
ETS300220

July 1, 1998 A.M.Q. Enneking

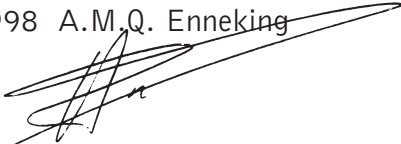

Date / Signature

E-King bv
P.O. Box 75089
1070 AB Amsterdam

Technical alterations reserved.

Copyright
E-King b.v.

Centurion Deuren B.V.

Koningsweg 2-13,
3762 EC Soest.
Telefoon (035) 60 30 982
www.centuriondeuren.nl

Showroom:

Nijverheidsweg 24 in Soest
(alleen op afspraak).

