

**CONTROL PANEL  
FOR 24 V GEARMOTORS**

FA01233-EN

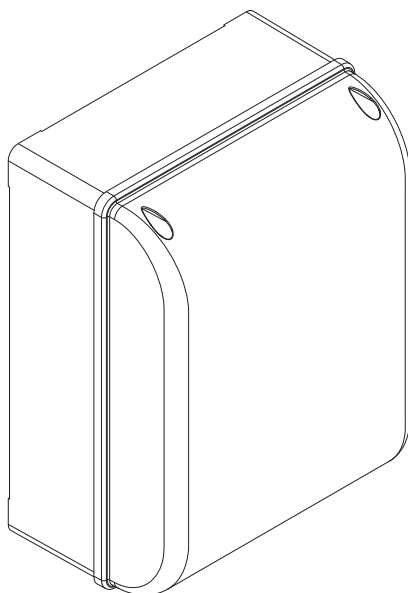



**ZL65**

**INSTALLATION MANUAL**

**IMPORTANT SAFETY INSTRUCTIONS WHEN INSTALLING**  
**WARNING: INCORRECT INSTALLATION MAY RESULT IN SERIOUS HARM, FOLLOW THESE INSTALLATION INSTRUCTIONS.**  
**THIS MANUAL IS EXCLUSIVELY INTENDED FOR PROFESSIONAL, SKILLED STAFF**

## LEGEND

-  This symbol shows which parts to read carefully.
-  This symbol shows which parts describe safety issues
-  This symbol shows which parts to tell users about.

## DESCRIPTION

Control panel for one or two-leaved swing gates with graphic display, divided into programming and warning and self-diagnosing safety devices.

The control panel is set up for:

- connecting the RGP1 module for reducing consumption;
  - connecting the ERLB emergency (blackout) operation and battery-recharging card.
  - connecting to the RIO-CONN card for configuring Rio-series wireless accessories;
  - connecting the UR042 module for remotely managing CAME operators, using the CAME CLOUD-specific system.
- All connections and links are rapid-fuse protected.

### Intended use

For private homes and apartment blocks.

-  Any installation and/or use other than that specified in this manual is forbidden.

### Technical data

Type	ZL65
Protection rating (IP)	54
Power supply (V - 50/60 Hz)	230 AC
Power supply motor (V)	24 DC
Stand-by consumption (W)	7
Stand-by consumption with the RGP1 (W) module	0.5
Maximum power (W)	300
Casing material	ABS
Operating temperature (°C)	-20 ÷ +55
Insulation class	□
Weight (Kg)	3.3

### Fuses

LINE FUSE - Line	2 A-F = 230V
ACCESSORIES - Accessories	2 A-F

## Dimensions (mm)

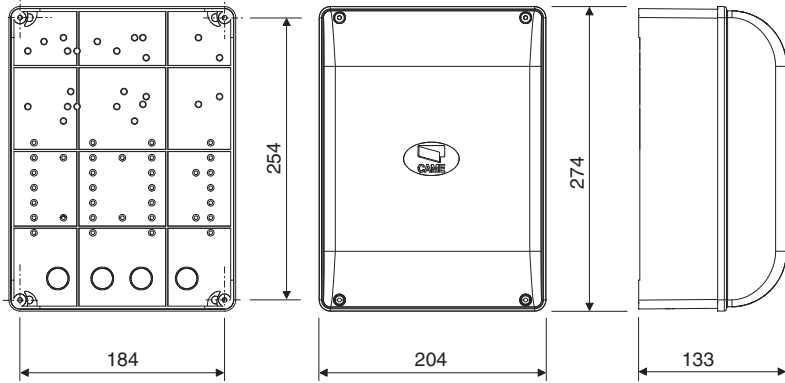

## Description of parts

- |   |  |
|---|--|
| <ol style="list-style-type: none"> <li>1. Line fuse</li> <li>2. Power supply terminals</li> <li>3. Terminals for signaling devices</li> <li>4. Gearmotors with encoder terminals</li> <li>5. Control devices terminals</li> <li>6. Safety devices terminals</li> <li>7. CRP connection terminals</li> <li>8. Keypad selector terminal</li> <li>9. Terminals for transponder devices</li> <li>10. Antenna terminal</li> <li>11. Connector for the UR042 module</li> <li>12. AF card connector</li> </ol> | <ol style="list-style-type: none"> <li>13. R700/R800 board connector</li> <li>14. Connector for the RIO-CONN card</li> <li>15. RSE board connector</li> <li>16. Memory Roll card connector</li> <li>17. Programming buttons</li> <li>18. Display</li> <li>19. Transformer</li> <li>20. Terminals for the RGP1 module</li> <li>21. Accessories fuse</li> <li>22. Housing for the UR042 module</li> <li>23. Housing for the RGP1 module</li> <li>24. Housing for the RLB battery-charger card</li> </ol> |
|---|--|

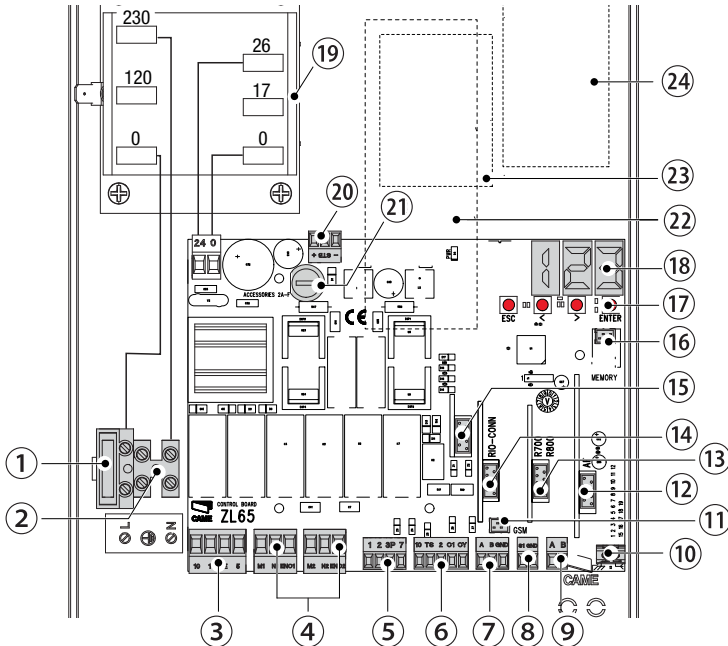

## GENERAL INSTALLATION INDICATIONS

⚠ Only skilled, qualified staff must install this product.

⚠ Warning! Before working on the control panel, cut off the main current supply and, if present, remove any batteries.

### Preliminary checks

⚠ Before installing the control panel, do the following:

- make sure the fastening points and the anchoring surface are solid and protected from impacts. Only use suitable nuts, bolts, dowels, and so on;
- make sure you have set up a suitable dual-pole cut off device, along the power supply, that is compliant with the installation rules. It should completely cut off the power supply according to category III surcharge conditions (that is, with minimum contact openings of 3 mm);
- ⊕ make sure that any connections inside the container (ones that ensure continuity to the protection circuit) are fitted with additional insulation with respect to those of other electrical parts inside;
- set up suitable tubes and conduits for the electric cables to pass through, making sure they are protected from any mechanical damage.

### Tools and materials

Make sure you have all the tools and materials you will need for installing in total safety and in compliance with applicable regulations. The figure shows some of the equipment installers will need.

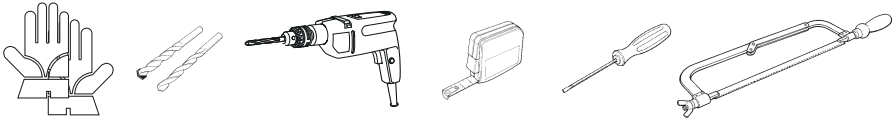

### Cable types and minimum thicknesses

Connection	Cable type	Cable length 1 < 15 m	Cable length 15 < 30 m
Control panel power supply 230 V AC	H05RN-F	2G x 1.5 mm <sup>2</sup>	2G x 2.5 mm <sup>2</sup>
Motor/encoder power supply 24 V DC	FROR CEI 20-22 CEI EN 50267-2-1	3 x 1.5 mm <sup>2</sup>	3 x 2.5 mm <sup>2</sup>
Flashing light		2 x 0.5 mm <sup>2</sup>	
Photocell transmitters		2 x 0.5 mm <sup>2</sup>	
Photocell receivers		4 x 0.5 mm <sup>2</sup>	
Command and safety device		2 x 0.5 mm <sup>2</sup>	
Antenna	the RG58 antenna	max 10 m	
Came Remote Protocol (CRP)	UTP CAT5	max 1000 m	

📖 If cable lengths differ from those specified in the table, establish the cable sections depending on the actual power draw of the connected devices and according to the provisions of regulation CEI EN 60204-1.

For multiple, sequential loads along the same line, the dimensions on the table need to be recalculated according to the actual power draw and distances. For connecting products that are not contemplated in this manual, see the literature accompanying said products

## INSTALLATION

### Fastening the control panel

Fasten the control panel in a protected area using suitable screws and dowels ❶.

📖 Only use 6 x 70 mm cylinder-head screws.

Drill through the pre-drilled holes (18 and 20 mm) under the control panel's base ❷.

⚠ Be careful not to damage the control board.

Enter the cable gland with the corrugated tubes for threading the electrical cables ❸.

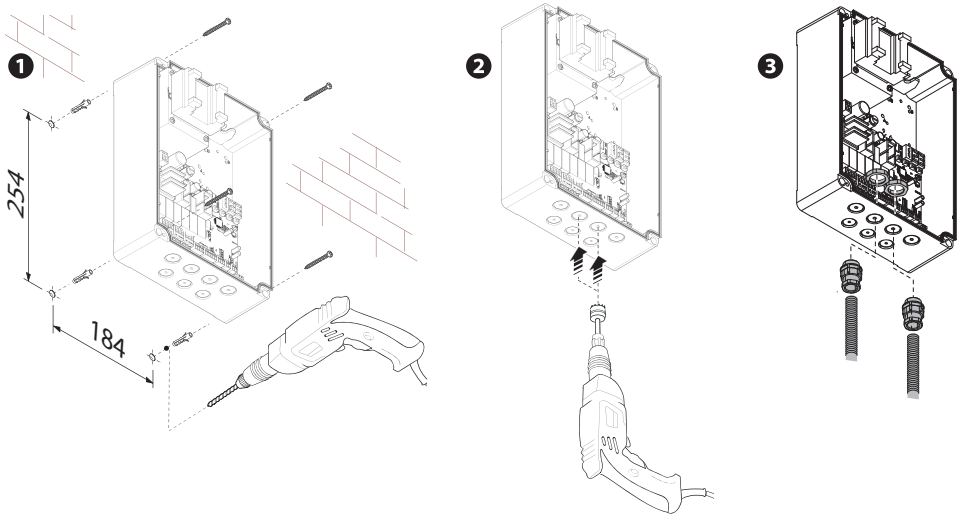

## ELECTRICAL CONNECTIONS AND PROGRAMMING

### Power supply

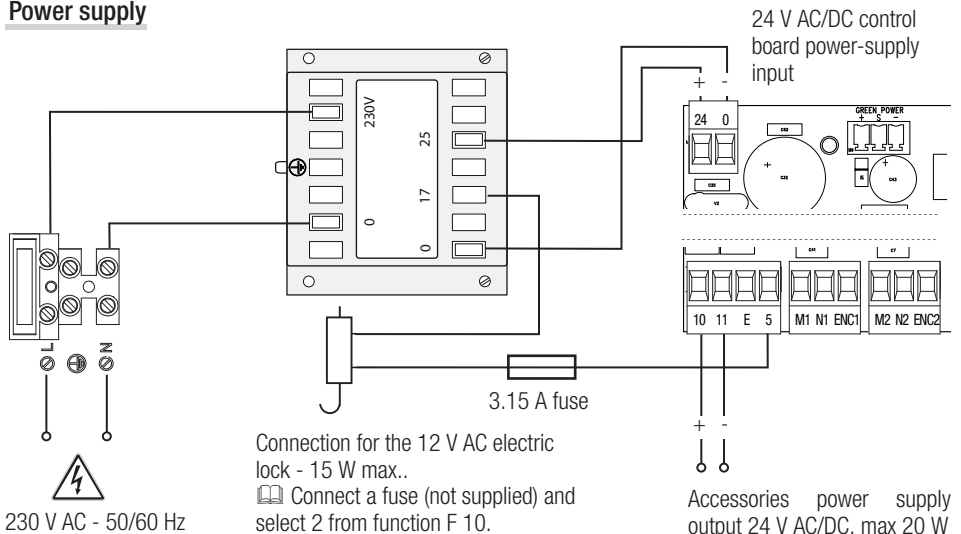

## Connecting gearmotor with encoder

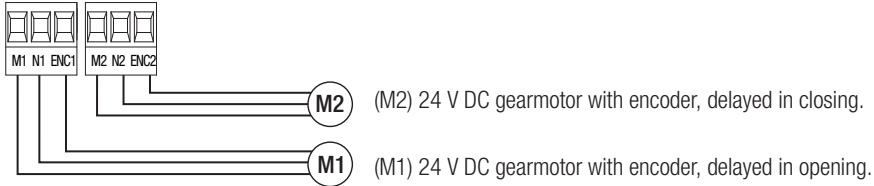

## Warning device

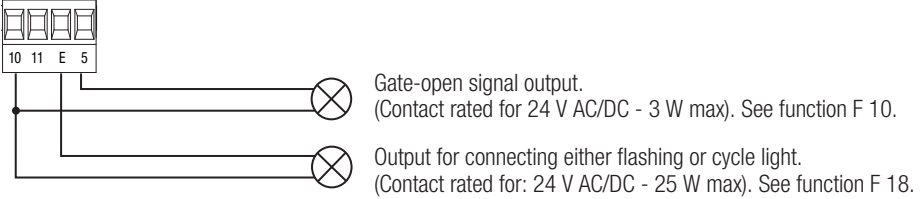

## Command and control devices

**⚠ WARNING!** Before fitting any plug-in card, such as the AF or R800 one, YOU MUST CUT OFF THE MAINS POWER SUPPLY and, if present, disconnect any batteries.

Connector for the UR042 module.

UR042 does not work if it is connected to the RGP1 module or the RSE card.

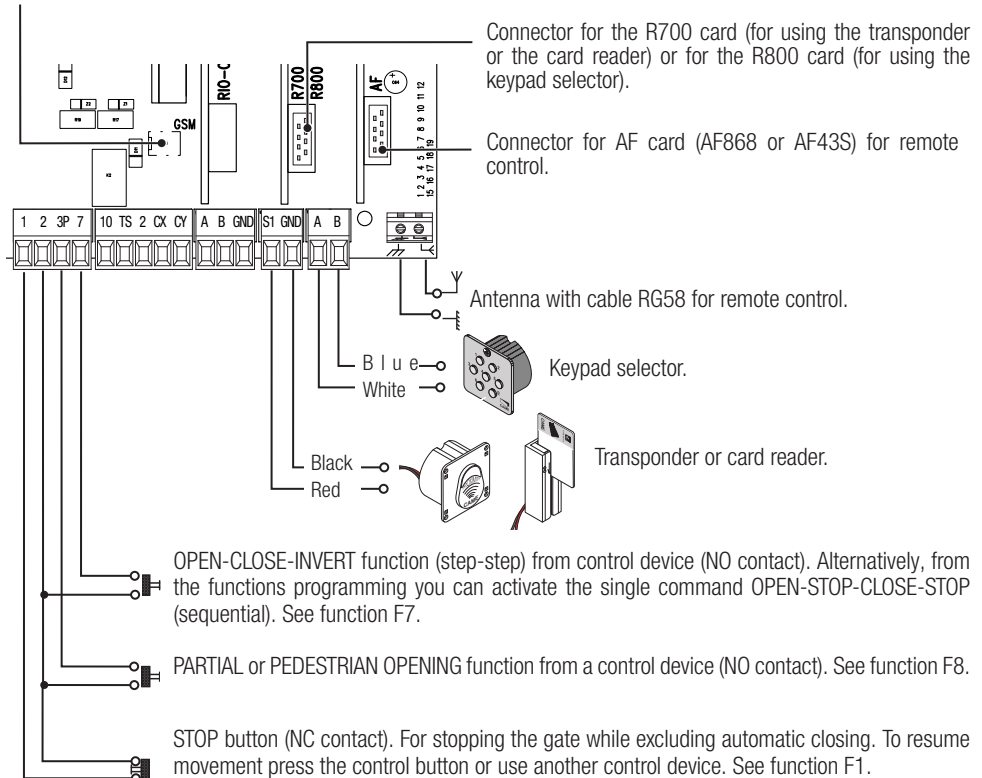

## Safety devices

### Photocells

Configure contact CX or CY (NC), input for safety devices, such as photocells, that comply with EN 12978 provisions. See CX input functions (Function F2) or CY (Function F3) in:

- C1 reopening during closing. when the gate is closing, opening the contact causes the inversion of movement until opening is complete;
- C2 reclosing during opening. When the gate is opening, opening the contact triggers the inversion of movement until the gate is fully closed;
- C3 partial stop. Stopping of the gate, if it is moving, with consequent automatic closing (if the automatic closing function has been entered);
- C4 obstacle wait. Gate stops, if it is moving, and once the obstruction is removed, it resumes its movement.

 If contacts CX and CY are not used they should be deactivated during programming.

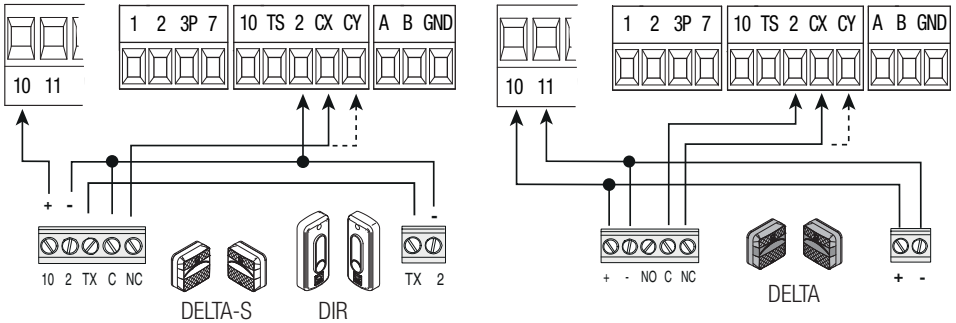

### Sensitive Safety Edges

Configure contact CX or CY (NC), input for safety devices, such as sensitive safety edges, that comply with EN 12978 provisions.

See CX input functions (Function F2) or CY (Function F3) in:

- C7 reopening during closing. when the gate is closing, opening the contact causes the inversion of movement until opening is complete;
- C8 reclosing during opening. When the gate is opening, opening the contact triggers the inversion of movement until the gate is fully closed.

 If contacts CX and CY are not used they should be deactivated during programming.

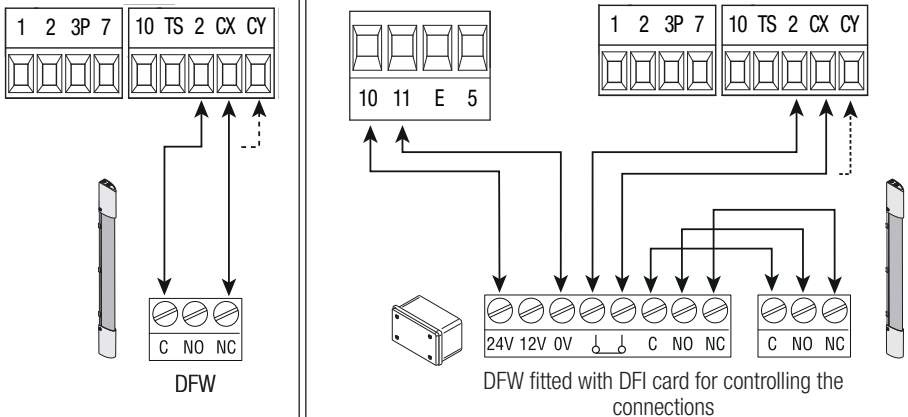

## Connecting the safety devices (i.e. the safety test)

At each opening and closing command, the control board checks the efficacy of the safety devices (such as, photocells).

Any malfunction will inhibit any command and E 4 will appear on the display.

For this type of connection, enable function F 5.

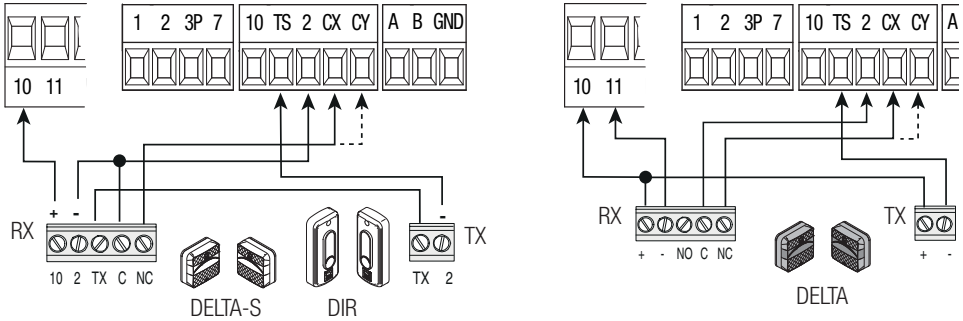

## Wireless devices

Fit the RIO-CONN card into the corresponding connector on the control board.

Set the function to be associated to the wireless device (F65, F66, F67 e F68).

Configure the wireless accessories (see the folder of the accessory you want to configure).

📖 If the devices are not configured with the RIO-CONN card, the E 18 error message is displayed.

⚠️ If the system has radiofrequency interferences, the wireless system will inhibit the operator's normal operating mode and the E 17 error message is displayed.

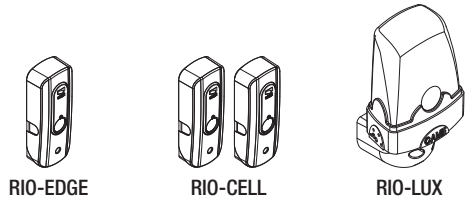
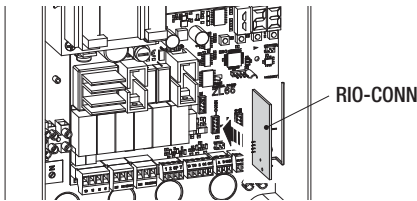

## Connection with Came Remote Protocol (CRP)

Fit the RSE card.

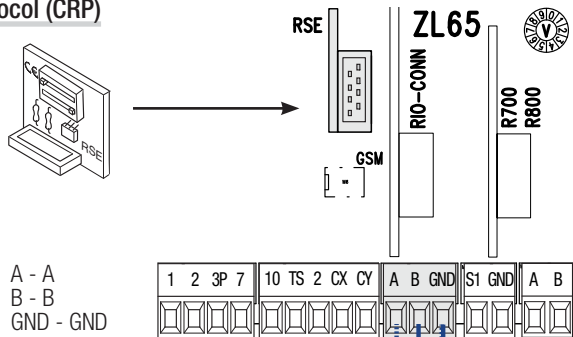

Serial connection of the RS485 with RSE card to the home & building automation system via CRP (Came Remote Protocol).

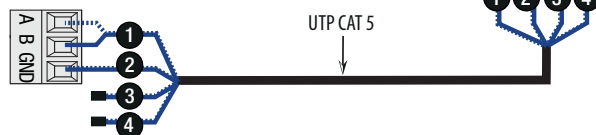



## Description of programming commands

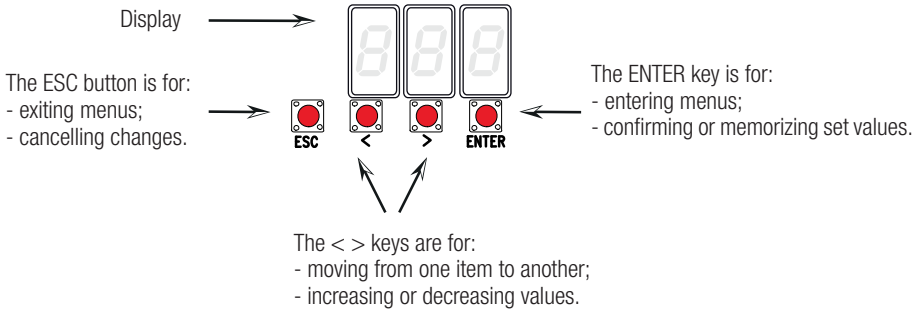

### Browsing the menu

To enter the menu, keep the ENTER button pressed for at least one second.

To select menu items, use the arrow keys ...

... then press ENTER

also for the submenus, use the arrow keys to select ...

... then press ENTER

To increase or decrease a value, use the arrow keys ...

... the press ENTER to confirm ...



... to exit the menu, wait 10 seconds or press ESC.



When the menu is active the system cannot be used.

## Functions map





- F 1 Total stop function (1-2)
- F 2 Function associated to input 2-CX
- F 3 Function associated to input 2-CY
- F 5 Safety test function
- F 6 Maintained action function
- F 7 Control mode on 2-7
- F 8 Control mode on 2-3P
- F 9 Obstruction detection with motor idle function
- F 10 Function associated to the open gate signal or electric lock enabling.
- F 11 Encoder exclusion
- F 12 Slowed-down start function
- F 13 Closing thrust function
- F 14 Sensor type selection function
- F 16 Ram jolt function
- F 18 Additional light function
- F 19 Automatic closing time
- F 20 Automatic closing time after partial opening
- F 21 Preflashing time
- F 22 Working time
- F 23 Delayed opening time
- F 24 Delayed closing time
- F 26 Ram jolt time
- F 28 Adjusting opening speed
- F 30 Adjusting opening slow-down speed
- F 33 Adjusting calibration speed
- F 34 Sensitivity during movement
- F 35 Sensitivity during slow-down
- F 36 Adjusting partial opening
- F 37 Adjusting the M1 gearmotor's opening slow-down start point
- F 38 Adjusting the M1 gearmotor's closing slow-down start point
- F 39 Adjusting the M1 gearmotor's opening approach starting point
- F 40 Adjusting the M1 gearmotor's closing approach starting point
- F 41 Adjusting the M2 gearmotor's opening slow-down starting point
- F 42 Adjusting the M2 gearmotor's closing slow-down starting point
- F 43 Adjusting the M2 gearmotor's opening approach starting point
- F 44 Adjusting the M2 gearmotor's closing approach starting point
- F 46 Setting the motor numbers
- F 49 Managing the serial connection
- F 50 Saving data in memory roll
- F 51 Reading memory roll data
- F 56 Peripheral number
- F 63 Changing COM speed
- F 65 Function associated to the RIO-EDGE [T1] input
- F 66 Function associated to the RIO-EDGE [T2] input
- F 67 Function associated to the RIO-CELL [T1] input
- F 68 Function associated to the RIO-CELL [T2] input
- U 1 Entering new user with an associated command
- U 2 Deleting single users
- U 3 Deleting all users
- U 4 Decoding the radio-frequency code
- A 1 Motor type
- A 2 Motor test
- A 3 Travel calibration
- A 4 Resetting parameters
- A 5 Counting maneuvers
- H 1 Software version









## Functions menu







-  **IMPORTANT! Start programming by first performing the MOTOR TYPE (A 1), F 46 MOTOR NUMBERS and A3 TRAVEL CALIBRATION functions.**
-  **Programming the features is to be done when the operator is stopped.**
-  **You can memorize up to 25 users.**

<b>F 1 Total stop [1-2]</b>	OFF= Deactivated ( <b>default</b> ) / ON= Activated
NC input – Gate stop that excludes any automatic closing; to resume movement, use the control device. The safety device is inserted into [1-2].	
<b>F 2 Input [2-CX]</b>	OFF= Deactivated ( <b>default</b> ) / 1 = C1 / 2 = C2 / 3 = C3 / 4 = C4 / 7 = C7 / 8 = C8
NC input – Can associate: C1 = reopening during closing by photocells, C2 = reclosing during opening by photocells, C3 = partial stop, C4 = obstruction wait, C7 = reopening during closing by sensitive safety-edges, C8 = reclosing during opening by sensitive safety-edges.  The C3 Partial stop function only appears if the F 19 Automatic closing time function is activated.	
<b>F 3 Input [2-CY]</b>	OFF = Deactivated ( <b>default</b> ) / 1 = C1 / 2 = C2 / 3 = C3 / 4 = C4 / 7 = C7 / 8 = C8
NC input – Can associate: C1 = reopening during closing by photocells, C2 = reclosing during opening by photocells, C3 = partial stop, C4 = obstruction wait, C7 = reopening during closing by sensitive safety-edges, C8 = reclosing during opening by sensitive safety-edges.  The C3 Partial stop function only appears if the F 19 Automatic closing time function is activated.	
<b>F 5 Safety test</b>	OFF= Deactivated ( <b>default</b> ) / 1 = CX / 2 = CY / 4 = CX+CY
After every opening or closing command, the board will check whether the photocells are working properly.  The safety test is always active for wireless devices.	
<b>F 6 Maintained action</b>	OFF= Deactivated ( <b>default</b> ) / ON= = Activated
The gate opens and closes by keeping the button pressed. Opening button on contact 2-3P and closing button on contact 2-7. All other control devices, even radio-based ones, are excluded.	
<b>F 7 Command [2-7]</b>	0 = Step-step ( <b>default</b> ) / 1 = Sequential
From the control device connected to 2-7 it performs the step-step (open-close-invert) or sequential (open-stop-close-stop) command.	
<b>F 8 Command [2-3P]</b>	0 = Pedestrian opening ( <b>default</b> ) / 1 = Partial opening
From the control device connected to 2-3P, it performs the pedestrian opening (completely opened M2 leaf) or the partial opening (partially opened 2 leaf): the degree of opening depends on the travel percentage adjustment set with F 36).	
<b>F 9 Obstruction detection when motor is idle</b>	OFF= Deactivated ( <b>default</b> ) / ON= = Activated
With the gate closed, opened or totally stopped, the gearmotor stays idle if the safety devices, that is, photocells or sensitive safety-edges detect an obstruction.	

<b>F 10 Open-gate signal or electric lock enabling</b>	0 = lit when gate is open or moving ( <b>default</b> ) 1 = when opening it flashes intermittently every half-second, when closing it flashes intermittently every second, stays lit when gate is open, stays off when gate is closed 2 = enabled electric lock.
It signals the gate status. The signaling device is connected to 10-5 or, alternatively, it enables the electric lock connected to transformer's 17 V-output and to terminal 5.  In the latter case, connect a 3.15 A fuse.	
<b>F 11 Encoder</b>	ON= Activated ( <b>default</b> ) / OFF = Deactivated
Managing slow-downs, obstruction detections and sensitivity.	
<b>F 12 Slowed-down start</b>	OFF= Deactivated ( <b>default</b> ) / ON= = Activated
With each opening and closing command, the gate starts moving slowly for a few seconds.	
<b>F 13 Closing thrust</b>	OFF= deactivated ( <b>default</b> ) / 1 = minimum thrust / 2 = medium thrust / 3 = maximum thrust
At the closing limit switch, the gearmotors make the leaves perform a brief closing thrust.	
<b>F 14 Select sensor type</b>	0 = transponder sensor or magnetic card reader command 1 = command with keypad selector ( <b>default</b> )
Setting the type of sensor for controlling the operator.	
<b>F 16 Ramming jolt</b>	OFF= Deactivated ( <b>default</b> ) / ON= = Activated
Before every opening or closing maneuver, the leaves thrust inwards to release the electric lock. The thrust time, is set with F 26.	
<b>F 18 Extra light</b>	0 = Flashing ( <b>default</b> ) / 1 = Cycle
Output on contact 10-E. Flashing light: it flashes during the gate's opening and closing phases. Cycle: it stays lit from the beginning of the opening until complete closing, including the waiting time before the automatic closing.	
<b>F 19 Automatic closing time</b>	OFF= Deactivated ( <b>default</b> ) / 1 = 1 second / ... / 180 = 180 seconds
The automatic-closing wait starts when the opening limit switch point is reached and can be set to between 1 and 180 seconds. The automatic closing does not turn on if any of the safety devices trigger when an obstruction is detected, after a total stop or during a power outage.	
<b>F 20 Automatic closing time after partial opening</b>	OFF= Deactivated ( <b>default</b> ) / 1 = 1 second / ... / 180 = 180 seconds
The wait before the automatic closing starts after a partial opening command for an adjustable time of between 1 s and 180 s. The automatic closing does not turn on if any of the safety devices trigger when an obstruction is detected, after a total stop or during a power outage.	
<b>F 21 Preflashing time</b>	OFF= Deactivated ( <b>default</b> ) / 1 = 1 second / ... / 10 = 10 seconds
Adjusting the pre-flashing time for the flashing light connected to 10-E before each maneuver. The flashing time is adjustable from 1 to 10 seconds.	

<b>F 22 Working time</b>	$5 = 5 \text{ seconds} / \dots / 120 = 120 \text{ seconds (default)} / \dots / 180 = 180 \text{ seconds.}$
Motors working time, when opening and closing. Adjustable between 5 and 180 seconds.	
<b>F 23 Delayed opening time</b>	$0 = 0 \text{ seconds} / \dots / 2 = 2 \text{ seconds (default)} / \dots / 10 = 10 \text{ seconds.}$
After an opening command, the M1 gearmotor starts delayed. The delay time is adjustable between 0 and 10 seconds.	
<b>F 24 Delayed closing time</b>	$0 = 0 \text{ seconds} / \dots / 5 = 5 \text{ seconds (default)} / \dots / 25 = 25 \text{ seconds.}$
After either a closing command or an automatic closing, the M2 gearmotor starts delayed. The delay time is adjustable between 0 and 25 seconds.	
<b>F 26 Ram jolt time</b>	$1 = 1 \text{ second (default)} / 2 = 2 \text{ seconds}$
After an opening or closing command, the gearmotor thrusts inward for an adjustable time between 1 and 2 seconds.	
<b>F 27 Lock time</b>	$1 = 1 \text{ second (default)} / 4 = 4 \text{ seconds}$
After an opening or closing command, the electric lock releases for an adjustable time between 1 and 4 seconds.	
<b>F 28 Travel speed</b>	$60 = \text{Minimum speed} / \dots / 100 = \text{Maximum speed (default)}$
Setting the gate's opening and closing speeds, calculated as a percentage.  For FA7024CB gearmotors, the minimum speed is 50.	
<b>F 30 Slow-down speed</b>	$10 = \text{Minimum speed} / \dots / 50 = \text{Speed (default)} / \dots / 60 = \text{Maximum speed}$
Setting the gate's opening and closing slow-down speed, calculated as a percentage.  For FA7024CB gearmotors, the minimum speed is 30.	
<b>F 33 Calibration speed</b>	$20 = \text{Minimum speed} / \dots / 50 = \text{Speed (default)} / \dots / 60 = \text{Maximum speed}$
Setting the gearmotors' speeds during calibration, calculated as a percentage.	
<b>F 34 Travel sensitivity</b>	$10 = \text{sensitivity} / \dots / 100 = \text{minimum sensitivity (default)}$
Adjusting obstruction detection sensitivity during boom travel.	
<b>F 35 Slow-down speed</b>	$10 = \text{sensitivity} / \dots / 100 = \text{minimum sensitivity (default)}$
Adjusting the obstruction-detection sensitivity during slow-downs	
<b>F 36 Adjusting partial opening</b>	$10 = 10\% \text{ of the travel} / \dots / 40 = 40\% \text{ of the travel (default)} / \dots / 80 = 80\% \text{ of the travel}$
Adjustment as a percentage of total travel, during gate opening.	
<b>F 37 M1 slow-down starting point</b>	$1 = 1\% \text{ of the travel} / \dots / 25 = 25\% \text{ of the travel (default)} / \dots / 60 = 60\% \text{ of the travel}$
Adjusting as a percentage of the total travel, the opening slow-down starting point of motor M1.  This function only appears if the Encoder function is activated.	
<b>F 38 M1 closing slow-down point</b>	$1 = 1\% \text{ of the travel} / \dots / 25 = 25\% \text{ of the travel (default)} / \dots / 60 = 60\% \text{ of the travel}$
Adjusting as a percentage of the total travel, the closing slow-down starting point of motor M1.  This function only appears if the Encoder function is activated.	

<b>F 39 M1 opening approach point</b>	1 = 1% of the travel / ... / 10 = 10% of the travel <b>(default)</b>
Adjusting as a percentage of the total travel, the M1 motor's opening approach starting point.  This function only appears if the Encoder function is activated.	
<b>F 40 M1 closing approach point</b>	1 = 1% of the travel / ... / 10 = 10% of the travel <b>(default)</b>
Adjusting as a percentage of the total travel, the M1 motor's closing-approach starting point.  This function only appears if the Encoder function is activated.	
<b>F 41 M2 motor's opening slow-down point</b>	1 = 1% of the travel / ... / 25 = 25% of the travel <b>(default)</b> / ... / 60 = 60% of the travel
Adjusting as a percentage of the total travel, the M2 motor's opening slow-down starting point.  This function only appears if the Encoder function is activated.	
<b>F 42 M2 motor's closing slow-down point</b>	1 = 1% of the travel / ... / 25 = 25% of the travel <b>(default)</b> / ... / 60 = 60% of the travel
Adjusting as a percentage of the total travel, the M2 motor's closing slow-down starting point.  This function only appears if the Encoder function is activated.	
<b>F 43 M2 motor's opening approach point</b>	1 = 1% of the travel / ... / 10 = 10% of the travel <b>(default)</b>
Adjusting as a percentage of the total travel, of the M2 motor's opening approach starting point.  This function only appears if the Encoder function is activated.	
<b>F 44 M2's closing approach point</b>	1 = 1% of the travel / ... / 10 = 10% of the travel <b>(default)</b>
Adjusting as a percentage of the total travel, the M2 motor's closing approach starting point.  This function only appears if the Encoder function is activated.	
<b>F 46 Number of motors</b>	OFF = M1 and M2 <b>(default)</b> / ON = M2
For setting the number of motors connected to the control panel.	
<b>F 49 Managing the serial connection</b>	OFF = Deactivated <b>(default)</b> / 3 = CRP
To enable functioning of the Came Remote Protocol.	
<b>F 50 Saving data</b>	OFF = Deactivated <b>(default)</b> / ON = Activated
Saving users and saved settings in memory roll.  This feature only appears if a memory roll has been fitted into the control board.	
<b>F 51 Read data</b>	OFF = Deactivated <b>(default)</b> / ON = Activated
Uploading data saved in memory roll.  This feature only appears if a memory roll has been fitted into the control board.	
<b>F 56 Peripheral number</b>	1 ----> 255
To set the peripheral's number from 1 to 255 for each control board when you have a system with several operators.	
<b>F 63 Changing COM speed</b>	0 = 1200 Baud / 1 = 2400 Baud / 2 = 4800 Baud / 3 = 9600 Baud / 4 = 14400 Baud / 5 = 19200 Baud / 6 = 38400 Baud / 7 = 57600 Baud / 8 = 115200 Baud
For setting the communication speed used in the CRP (Came Remote Protocol) connection system.	

<b>F 65 Wireless input RIO-EDGE</b> OFF= Deactivated ( <b>default</b> ) / 7 = P7 / 8 = P8 <b>[T1]</b>	
RIO-EDGE wireless safety device associated to any function chosen among those available: P7 = reopening during closing, P8 = reclosing during opening. For programming, see the instructions that come with the accessory.  This function only appears is the control board has been fitted with a RIO-CONN card.	
<b>F 66 Wireless input RIO-EDGE</b> OFF= Deactivated ( <b>default</b> ) / 7 = P7 / 8 = P8 <b>[T2]</b>	
RIO-EDGE wireless safety device associated to any function chosen among those available: P7 = reopening during closing, P8 = reclosing during opening. For programming, see the instructions that come with the accessory.  This function only appears is the control board has been fitted with a RIO-CONN card.	
<b>F 67 Wireless input RIO-CELL</b> OFF= Deactivated ( <b>default</b> ) / 1 = P1 / 2 = P2 / 3 = P3 / 4 = P4 <b>[T1]</b>	
RIO-CELL is associated to any function chosen among those available: P1 = reopening during closing; P2 = reclosing during opening; P3 = partial stop; P4 = obstruction wait. For programming, see the instructions that come with the accessory.  This function only appears is the control board has been fitted with a RIO-CONN card.	
<b>F 68 Wireless input RIO-CELL</b> OFF= Deactivated ( <b>default</b> ) / 1 = P1 / 2 = P2 / 3 = P3 / 4 = P4 <b>[T2]</b>	
RIO-CELL is associated to any function chosen among those available: P1 = reopening during closing; P2 = reclosing during opening; P3 = partial stop; P4 = obstruction wait. For programming, see the instructions that come with the accessory.  This function only appears is the control board has been fitted with a RIO-CONN card.	
<b>U 1 Entering a user</b>	1 = Step-step command (open-close) / 2 = Sequential command (open-stop-close-stop) / 3 = Only open command / 4 = Partial command
Entering up to up to a 25 users maximum and associating to each one a function chosen among the existing ones. This must be done via transmitter or other control device (see "ENTERING USERS WITH ASSOCIATED COMMAND" paragraph).	
<b>U 2 Deleting a user</b>	
Deleting a single user	
<b>U 3 Deleting users</b>	OFF= Deactivated / ON= = Deleting all users
Deleting all users.	
<b>U 4 Decoding the radio-frequency code</b>	Select the type of transmitter radio coding that you wish to save on the control board.  When you select a radio coding, all saved transmitter are automatically deleted.  TWIN's coding lets you save multiple users with the same key (Key block). <b>1 = all of the series (default)/2 = only Rolling Code series /3 = only TWIN series</b>
<b>A 1 Motor type</b>	1 = SWN20 - SWN25 ( <b>default</b> ) / 2 = FA7024CB
Selecting the gearmotor used on the system.	
<b>A 2 Motors test</b>	OFF= Disable / ON= = Activate
Test for checking the gearmotors' proper rotating directions (see the MOTORS TEST paragraph).	

### A 3 Travel calibration

OFF= Disable / ON= Activate

Automatic calibration of the gate-leaf run (see the TRAVEL CALIBRATION paragraph).

 This function appears only if the Encoder function is activated.

### A 4 Resetting parameters

OFF= Disable / ON= Activate

Warning! The default settings are restored and the travel calibration deleted.

### A 5 Counting maneuvers

OFF= Number of maneuvers made / ON= Deleting all maneuvers

For viewing the number of maneuvers completed or for deleting them (001 = 100 maneuvers; 010 = 1,000 maneuvers; 100 = 10,000 maneuvers; 999 = 99,900 maneuvers; CSI = maintenance job)

### H 1 Version

View the firmware version.

## Motors test

Select A 2.

Press ENTER to confirm.

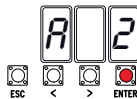

Select 1 and press ENTER to confirm the motors test procedure.

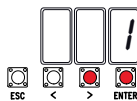

The following [---] characters will be displayed while waiting for a command.

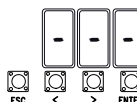

Keep pressed the > key and check whether the M2 second gearmotor's leaf performs an opening maneuver.

 If the leaf performs an opening maneuver, invert the motor's phases.

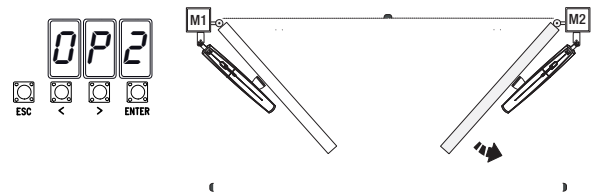

Perform the same procedure using the < arrow key to check the M1 first gearmotor's leaf.

 If the leaf performs an opening maneuver, invert the motor's phases.

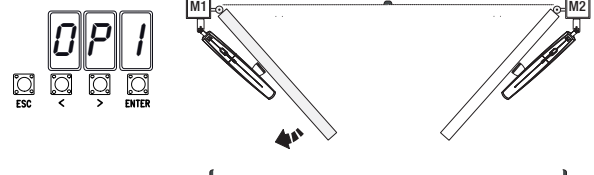



## Travel calibration

📖 Before calibrating the gate travel, position the gate half-way, check that the maneuvering area is clear of any obstruction and check that there are mechanical opening and closing stops.

⚠ The mechanical end-stops are obligatory.

Important! During calibration, all safety devices will be disabled.

Select A 3.

Press ENTER to confirm.

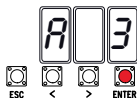

Select 1 and press ENTER to confirm the travel calibration operation.

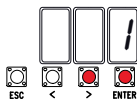

The first gearmotor leaf will perform a closing maneuver until the closing strike ...

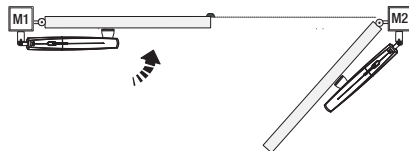
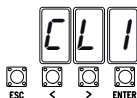

... then, the second gearmotor leaf will perform the same maneuver ...

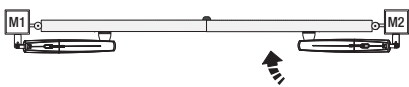
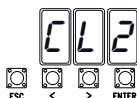

... the the second gearmotor's leaf will perform an opening maneuver until the closing strike ...

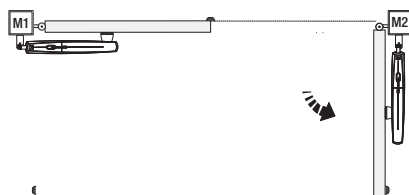
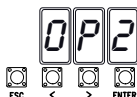

... the first gearmotor's leaf will perform the same maneuver.

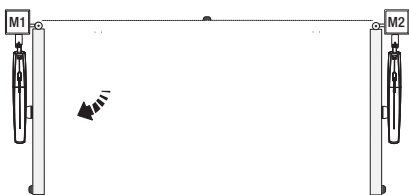
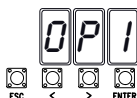

When entering/deleting users, the flashing numbers that appear, are numbers that can be used for other users you may wish to enter (maximum 25 users).

## Entering a user with an associated command

Select U 1  
Press ENTER to confirm.

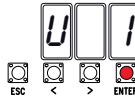

Select a command to associate to the user.  
The commands are:  
- step-step (open-close) = 1;  
- sequential (open-stop-close-stop) = 2;  
- open = 3;  
- partial opening/pedestrian = 4.  
Press ENTER to confirm...

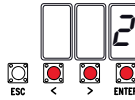

... a number from 1 to 25 will flash for a few seconds  
Send the code from the transmitter or other control device, such as, a keypad selector or a transponder.  
Associate the number to the entered user.

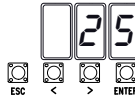

User	Associated command
1 -	
2 -	
3 -	
4 -	
5 -	
6 -	
7 -	
8 -	
9 -	
10 -	
11 -	
12 -	
13 -	
14 -	
15 -	
16 -	
17 -	
18 -	
19 -	
20 -	
21 -	
22 -	
23 -	
24 -	
25 -	

## Deleting a single user

Select U 2.  
Press ENTER to confirm.

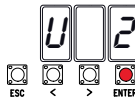

Use the arrow keys select the number of the user you wish to delete.  
Press ENTER to confirm...



... Clr will appear on the screen to confirm deletion.



## Memory Roll Card

To memorize user data and configure the system, to then reuse them with another control board even on another system.

After memorizing the data, it is best to remove the Memory Roll.

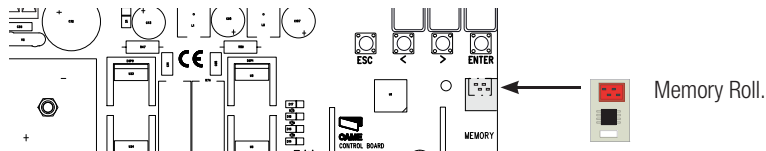

## ILLUSTRATION OF THE SLOW-DOWN AND APPROACH AREAS AND POINTS

The travel areas and slow-down and approach points are tested to comply with the parameters set forth by Technical Regulations EN 12445 and EN 12453 for impact force compatibility of moving gate leaves.

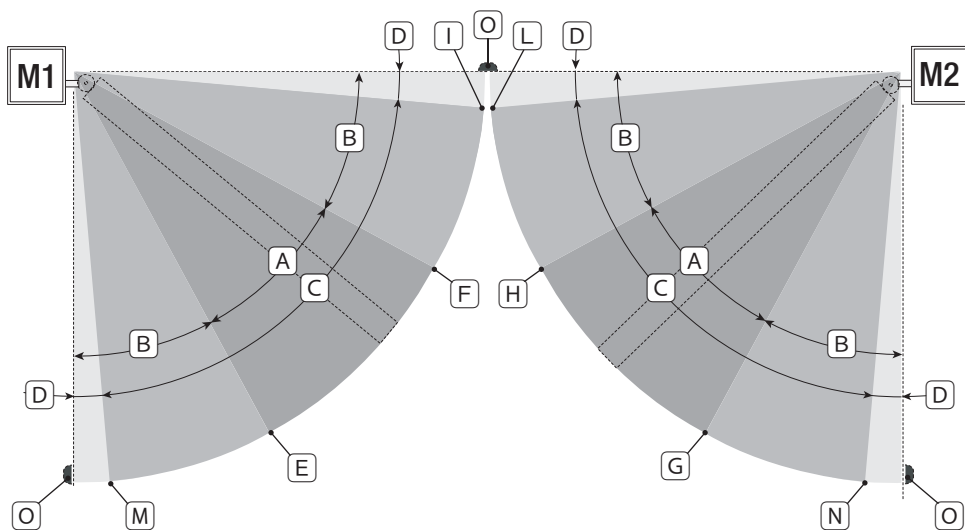

- A = Movement area at normal speed.
- B\* = Movement area at slowed-down speed.
- C = Encoder intervention zone with movement inversion.
- D = Encoder intervention zone with movement stopped.
- E = Opening slow-down starting point for M1.
- F = Closing slow-down starting point for M1.
- G = Opening slow-down starting point for M2.
- H = Closing slow-down starting point for M2.
- I\*\* = Closing approach starting point for M1.
- L\*\* = Closing approach starting point for M2.
- M\*\* = Opening slow-down starting point for M1.
- N\*\* = Opening slow-down starting point for M1
- O = Strike plates..

\* Minimum 600 mm from the strike plate.

\*\* Set the closing-rest percentage for function F 39 - F 40 for the first motor (M1) and F43 - F44 for the second motor (M2) so as to achieve a distance of less than 50 mm from the strike plate.

## ERROR MESSAGE

 The error messages are shown on the display.

E 1	The travel calibration was interrupted when the STOP button was activated
E 2	Calibrating the incomplete travel
E 3	Encoder broken
E 4	Services test error
E 7	Insufficient working time
E 9	Closing obstruction
E 10	Opening obstruction
E 11	Maximum number of detected obstructions
E 14	Serial communication error
E 17	Wireless system error
E 18	The wireless system hasn't been configured.

## FINAL OPERATIONS

### Fastening the cover

Once finished with the electrical connections and powering up, fit the cover and secure it using the supplied screws.

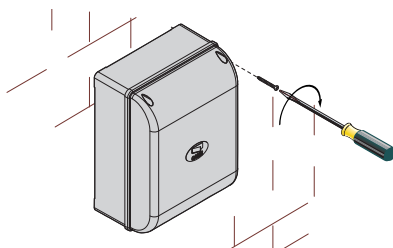

## DISMANTLING AND DISPOSAL

Always make sure you comply with local laws before dismantling and disposing of the product. The packaging materials (cardboard, plastic, and so on) should be disposed of as solid household waste, and simply separated from other waste for recycling.

Whereas other components (control boards, batteries, transmitters, and so on) may contain hazardous pollutants. These must therefore be disposed of by authorized, certified professional services.  
**DO NOT DISPOSE OF IN NATURE!**

## REFERENCE REGULATIONS

The product complies to the reference regulations in effect.

**CAME** 

[CAME.COM](http://CAME.COM)

**CAME S.P.A.**

Via Martiri Della Libertà, 15  
31030 Dosson di Casier - Treviso - Italy  
tel. (+39) 0422 4940 - fax. (+39) 0422 4941