

CONTROL PANEL
FOR 24V OPERATORS

ZL180 SERIES



INSTALLATION MANUAL
ZL180

English

EN

“IMPORTANT INSTALLATION, SAFETY INSTRUCTIONS”

“CAUTION: IMPROPER INSTALLATION MAY CAUSE SERIOUS DAMAGE, FOLLOW ALL INSTALLATION INSTRUCTIONS CAREFULLY”

“THIS MANUAL IS ONLY FOR PROFESSIONAL INSTALLERS OR QUALIFIED PERSONS”



1 Legend of symbols



This symbol indicates sections to be read with particular care.



This symbol indicates sections concerning safety



This symbol indicates notes to communicate to users.

2 Intended use and application

2.1 - INTENDED USE

The ZL180 control panel is designed to control the F7024N, A3024N and A5024N swing gate operators.



The use of this product for purposes other than as described above and installation executed in a manner other than as instructed in this technical manual are prohibited.

2.2 - APPLICATION

Make sure you respect the distances and cable diameters as shown in “cable types and minimal thicknesses” table.

The overall power of the motors must not exceed 300 W.

3 Reference Standards

For its quality processes management Came Cancelli Automatici is ISO 9001:2000 certified, and for its environmental management it is ISO 14001 certified. Came designs and manufactures entirely in Italy.

This product complies with the following standards: see chapter 13 - Conformity declaration - pag. 21.

4 Description

This product is engineered and manufactured by CAME cancelli automatici s.p.a. and complies with current safety regulations. Guaranteed 24 months if not tampered with.

The control panel works on 230 V AC of power, through the terminals L-N, 50/60 Hz frequency.

Both command and control devices and accessories are 24 V powered. Warning! Accessories must not exceed 34 W overall.

The control unit is fitted with an amperometric device which constantly regulates the motor's drive coefficient.

When the gate runs into an obstacle, the amperometric sensor immediately detects an overcharge in the drive and redirects the gate's direction of movement, and:

- opens it if it is closing⁽¹⁾;
- closes it if it is opening.

⁽¹⁾ Warning!: in this case, after 3 consecutive obstacle detections, the gate will stop open excluding the automatic closing function; for movement to start again press the command button or use the remote control.

All connections are protected by quick fuses, see table.

The card provides and controls the following functions:

- automatic closing after an open-command;
- pre-flashing by the motion indicator;
- obstacle detection when gate is still in any position;
- continual monitoring of photocell operation.

The following command modes are possible:

- open/close;
- open/close and maintained action;
- partially open;
- complete stop;
- open/stop/close.

After detecting an obstacle and depending on the type of connection used, the photocells may cause:

- reopening of the gate when it is closing;
- partial stop.

Apposite trimmers regulate:

- the automatic closing run time;
- the second gate leaf's motion time difference;
- the amperometric device's detection sensitivity, in separately in terms of normal opening and closing and braking.

Further implemented options:

- controlling of just one gearmotor;
- peripheral speed reduction (for gate leaves of over 3 m);
- option to change opening endpoint from Stop to Deceleration. With the function of slowing down is mandatory setback mechanical;
- connecting up an electric lock (alternatively to the 2nd radio channel or the “Open Gate” indicator light) and possibly adding the “Ram Blow” function.

TECHNICAL FEATURES

Power supply	230 V - 50/60 Hz
max. rated power	300 W
Power draw when idling	85 mA
Max power of 24 V accessories	34 W
Insulation rating	II
Material	ABS
Protection rating	IP54
operating temperature	-20 / +55°C

FUSES

protection:	fuse type:
Motor/s	6.4 A-F
Electronic board (power supply line)	1.6 A-F
Accessories	2 A-F
Control devices	630 mA-F

4.1 - DIMENSIONS, SPANS AND ANCHORING HOLES

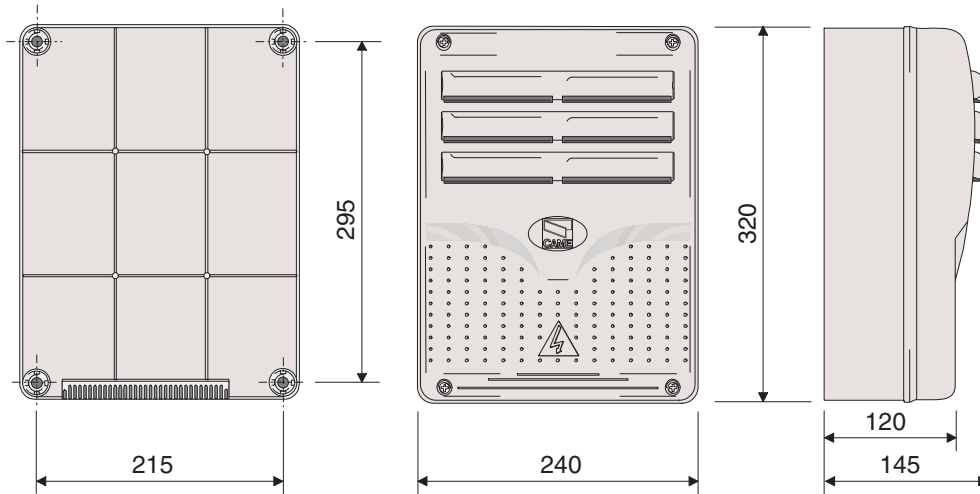

4.2 - MAIN COMPONENTS

- 1 - Transformer
- 2 - Control unit fuse
- 3 - Trimmers (see page 9)
- 4 - Buttons for memorising the radio code
- 5 - Plug for the remote control frequency card
- 6 - Terminal board for connecting the antenna
- 7 - Terminal blocks for connecting accessories, control and safety
- 8 - Terminal board for connecting the gearmotors
- 9 - Terminal board for 230 V AC power grid
- 10 - Line fuse
- 11 - M1 motor fuse
- 12 - M2 motor fuse
- 13 - Accessories fuse
- 14 - Functions selector
- 15 - Control and signalling LED unit

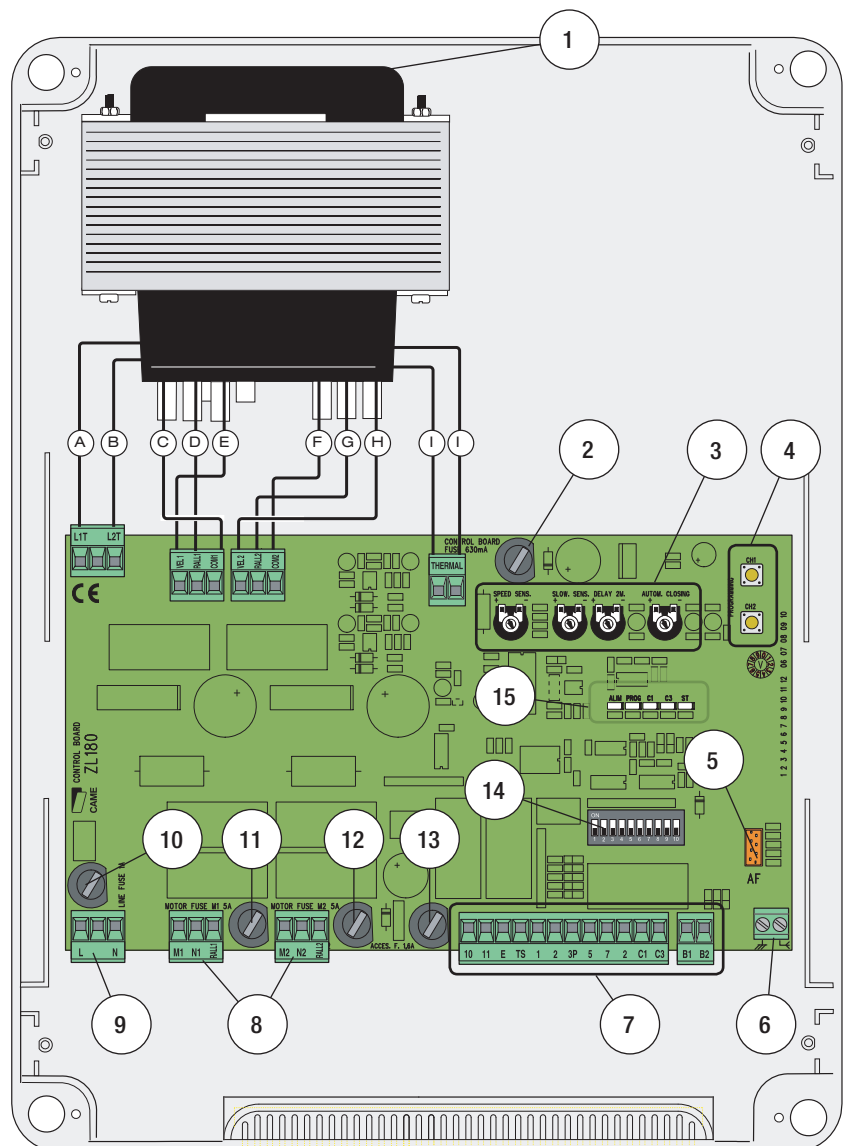

LINKS

THE TRANSFORMER

- A = White
 B = Black
 C = Violet
 D = Grey
 E = Orange
 F = Red
 G = Blue
 H = Brown
 I = Yellow

Warning! Before acting on the machinery, cut off the main power supply and disconnect any emergency batteries.

5 Installation

5.1 - PRELIMINARY CHECKS



Before installing do the following:

- Check that the panel's anchoring point is protected from possible blows, and that the anchoring surface is solid. Also check that the anchoring is done using the appropriate bolts, screws etc.
- Make sure you have a suitable omnipolar cut-off device with contacts more than 3 mm apart, and independent (sectioned off) power supply.
- ⚡ Make sure that any connections inside the case (that provide continuance to the protective circuit) are fitted with extra insulation as compared to the other conductive parts inside;
- Make sure you have suitable tubing and conduits for the electrical cables to pass through and be protected against mechanical damage.

5.2 - TOOLS AND MATERIALS

Make sure you have all the tools and materials you will need for the installation at hand to work in total safety and compliance with the current standards and regulations. The following figure illustrates the minimum equipment needed by the installer. Here are some examples.

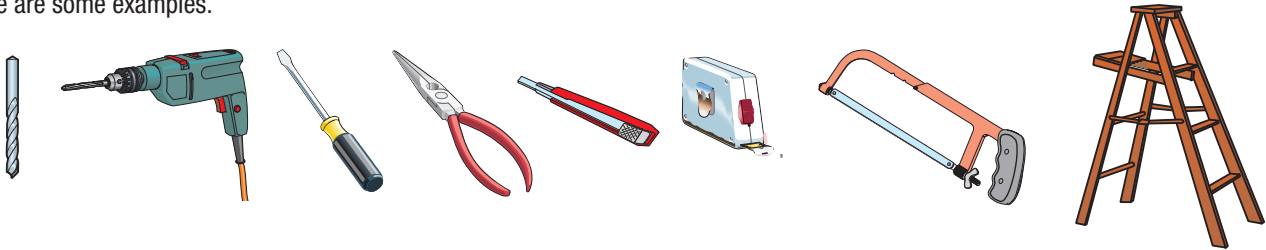

5.3 - FIXING AND MOUNTING THE BOX

Fix the base of the panel in a protected area; we suggest using round top Phillips recessed head screws of max. 6mm in diameter.

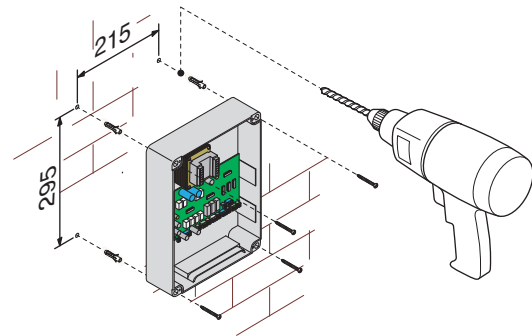

Perforate the pre-punched holes and insert the cable glands with the corrugated tubing for the electrical cables to travel through
N.B.: the pre-punched holes have the following diameters:
23mm 29 and 37 mm.

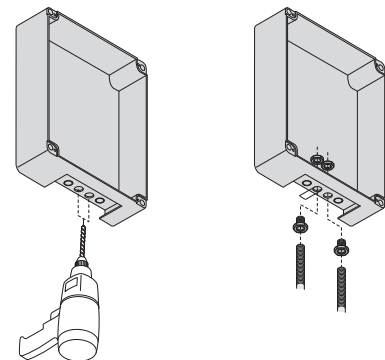

Assemble the pressure hinges.

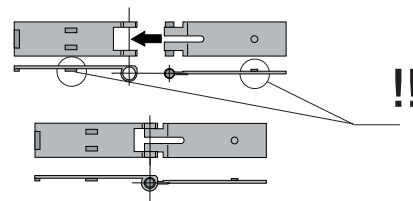

Insert the pressure hinges into the box (on the left or right as you wish) and set them using the provided screws and washers.

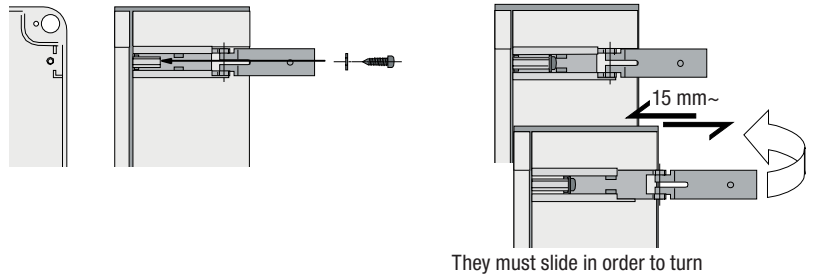

Snap the cover into place onto the hinges. Close it and fix it using the provided screws.

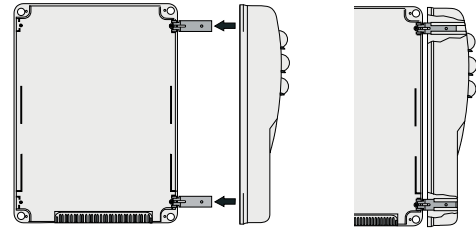

After the adjustments and settings, fix the cover using the provided screws.

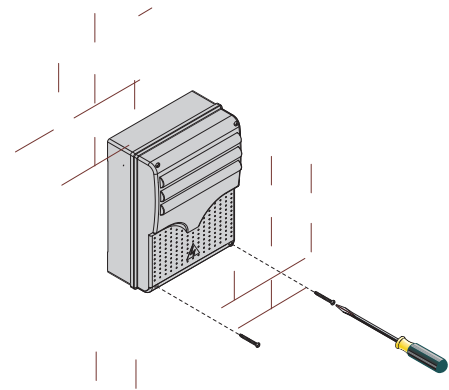

6 Electrical connections

6.1 - CABLE LIST AND MINIMUM THICKNESSES

Connections	Type of cable	Length of cable 1 < 10 m	Length of cable 10 < 20 m	Length of cable 20 < 30 m
Control panel power supply 230 V	FROR CEI 20-22 CEI EN 50267-2-1	3G x 1,5 mm ²	3G x 2,5 mm ²	3G x 4 mm ²
Motor power supply 24 V		3 x 1 mm ²	3 x 1,5 mm ²	3 x 2,5 mm ²
flashing lamp		2 x 0,5 mm ²	2 x 1 mm ²	2 x 1,5 mm ²
Transmitter photocells		2 x 0,5 mm ²	2 x 0,5 mm ²	2 x 0,5 mm ²
Receiver photocells		4 x 0,5 mm ²	4 x 0,5 mm ²	4 x 0,5 mm ²
Power supply to accessories		2 x 0,5 mm ²	2 x 0,5 mm ²	2 x 1 mm ²
Control and safety devices		2 x 0,5 mm ²	2 x 0,5 mm ²	2 x 0,5 mm ²
Antenna connection	RG58	max. 10 m		

N.B.: If the cable length differs from that specified in the table, then you must determine the proper cable diameter based on the actual power draw from the connected devices and according to the CEI EN 60204-1 standards.

For connections that require several, sequential loads, the sizes given on the table must be re-evaluated based on actual power draw and distances.

When connecting products that are not specified in this manual, please follow the documentation provided with said products.

6.4 - POWER SUPPLY TO AND ACCESSORIES

Terminals for powering the following accessories:
 - 24 V AC (normally alternated power)
 - 24 V AC (continuous power) when the emergency batteries are in operation.
 Overall power allowed: 34 W

Power supply
 230 V AC 50/60 Hz

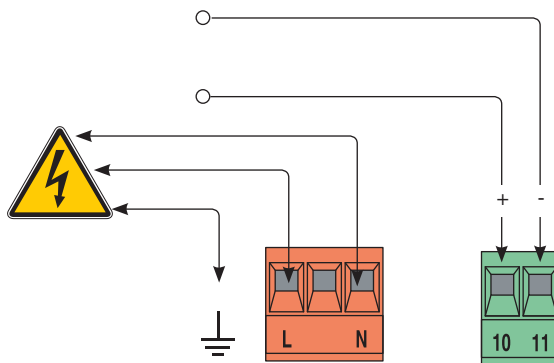

6.3- SIGNALLING AND LIGHTING DEVICES

Open gate indicator-light
 (socket rating: 24 V - 3 W max.).
 - Turns on when the gate is ajar or open. It turns off when the gate is closed.
 (Also see Chapt. 6.5)

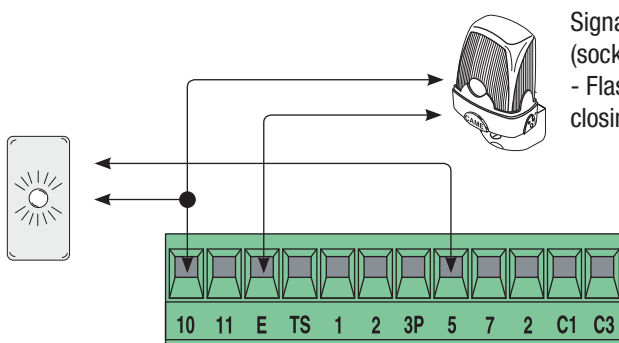

Signal Flasher
 (socket rating: 24 V - 25 W max.)
 - Flashes during opening and closing phases

A3024N-A5024N gearmotors

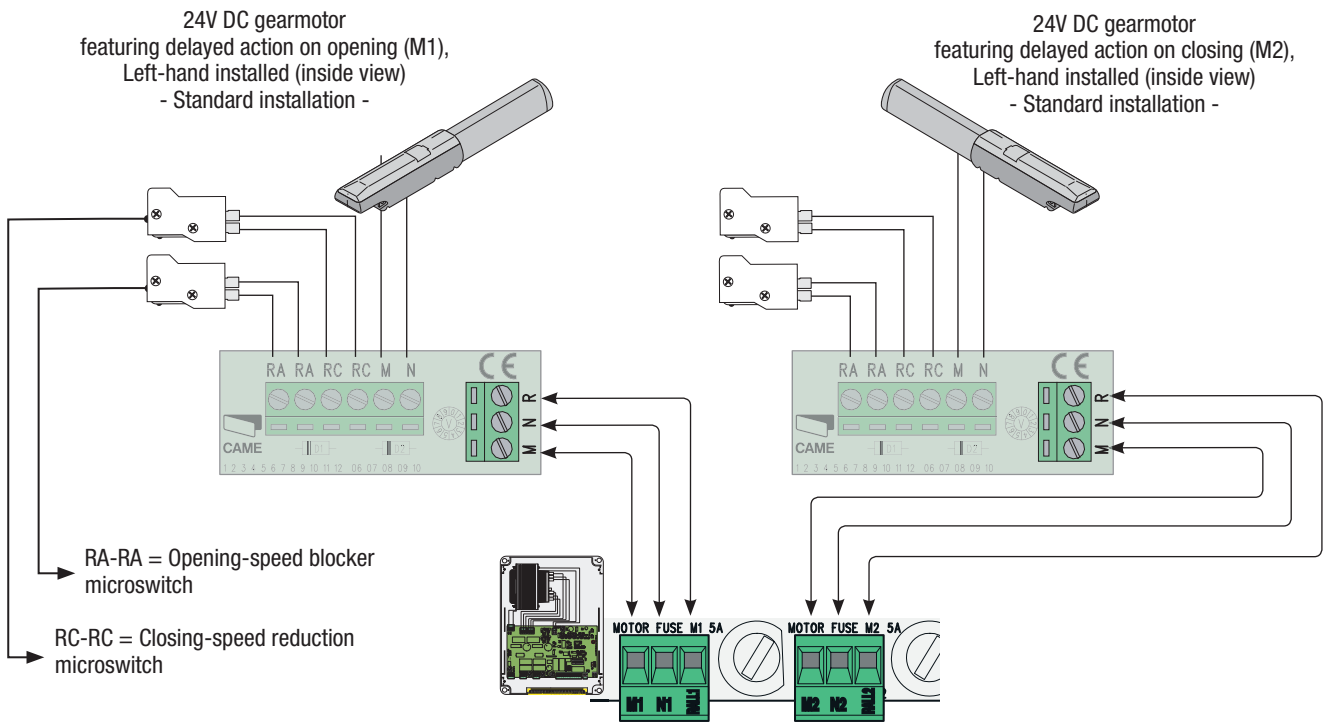

A3024N-A5024N gearmotors

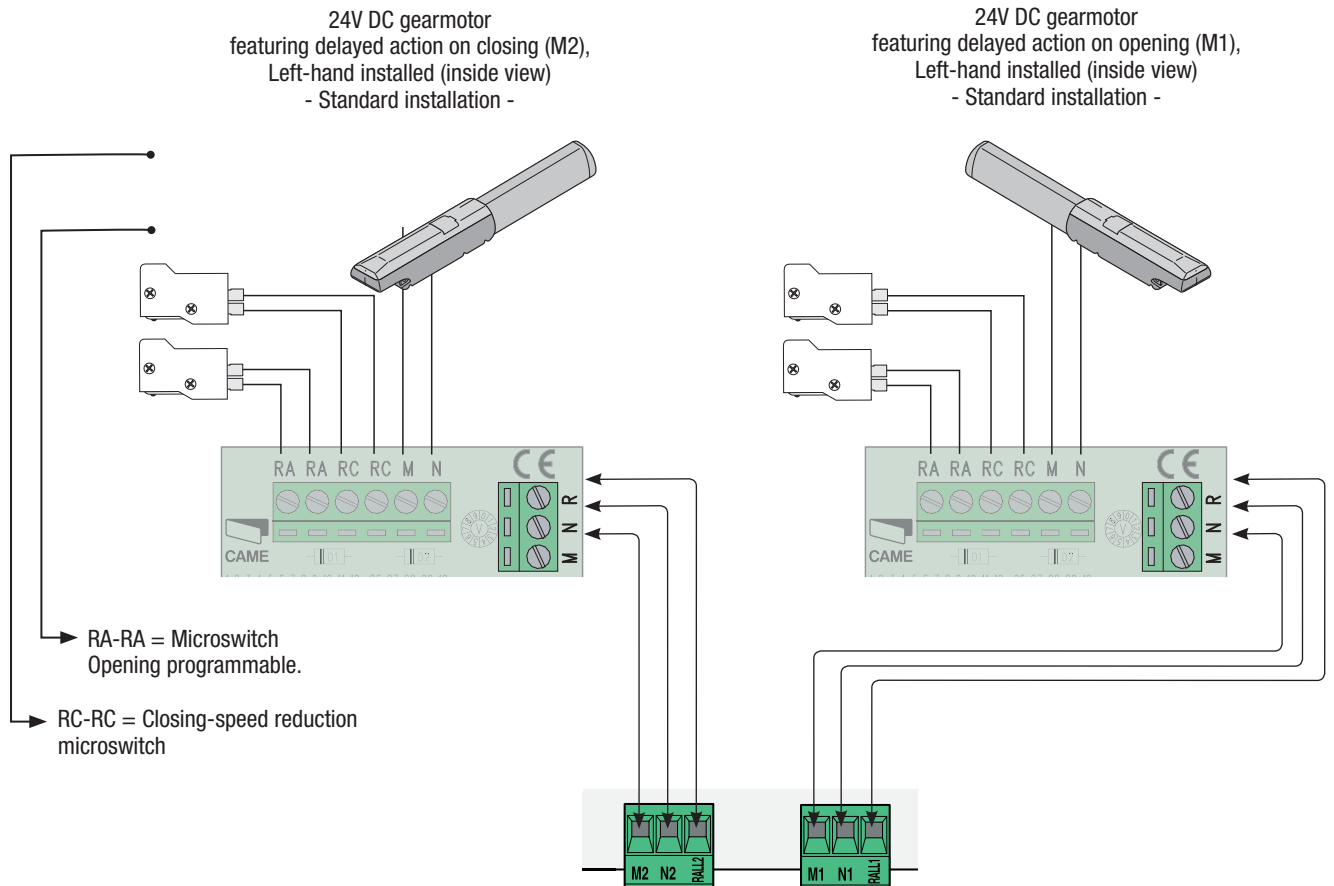

F7024N gearmotors

24V DC gearmotor
featuring delayed action on opening
(M1),
Left-hand installed (inside view)
- Standard installation -

24V DC gearmotor
featuring delayed action on closing
(M2),
Left-hand installed (inside view)
- Standard installation -

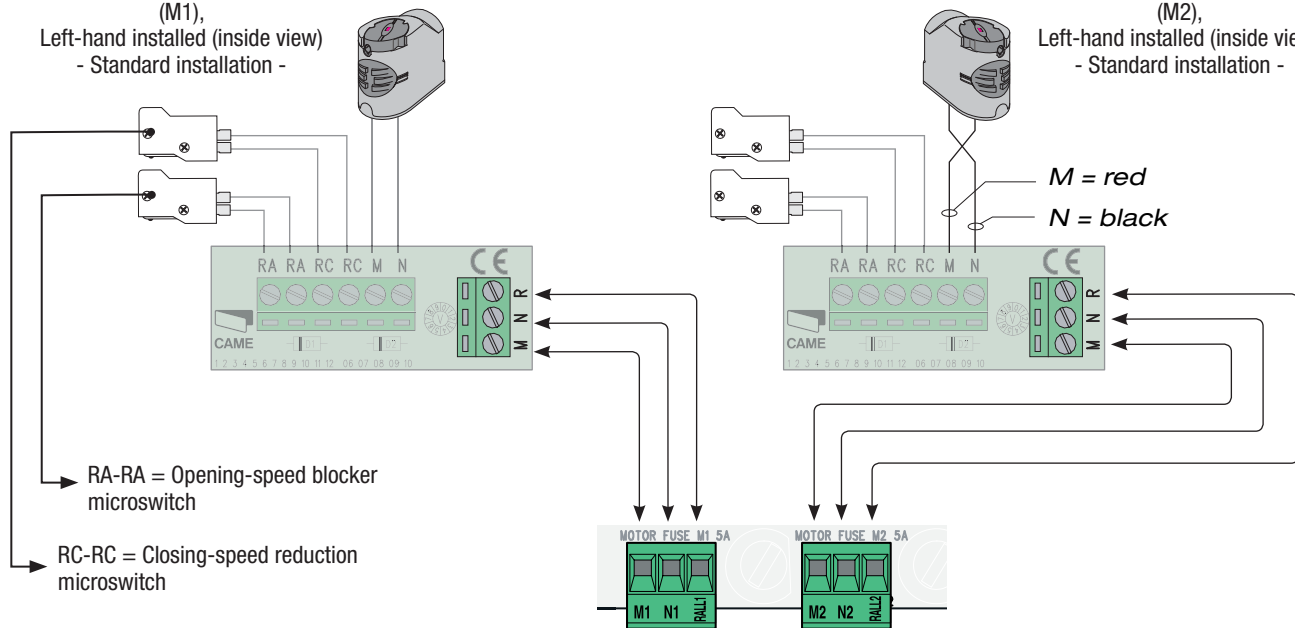

F7024N gearmotors

24V DC gearmotor
featuring delayed action on closing
(M2),
Left-hand installed (inside view)
- Standard installation -

24V DC gearmotor
featuring delayed action on opening
(M1),
Left-hand installed (inside view)
- Standard installation -

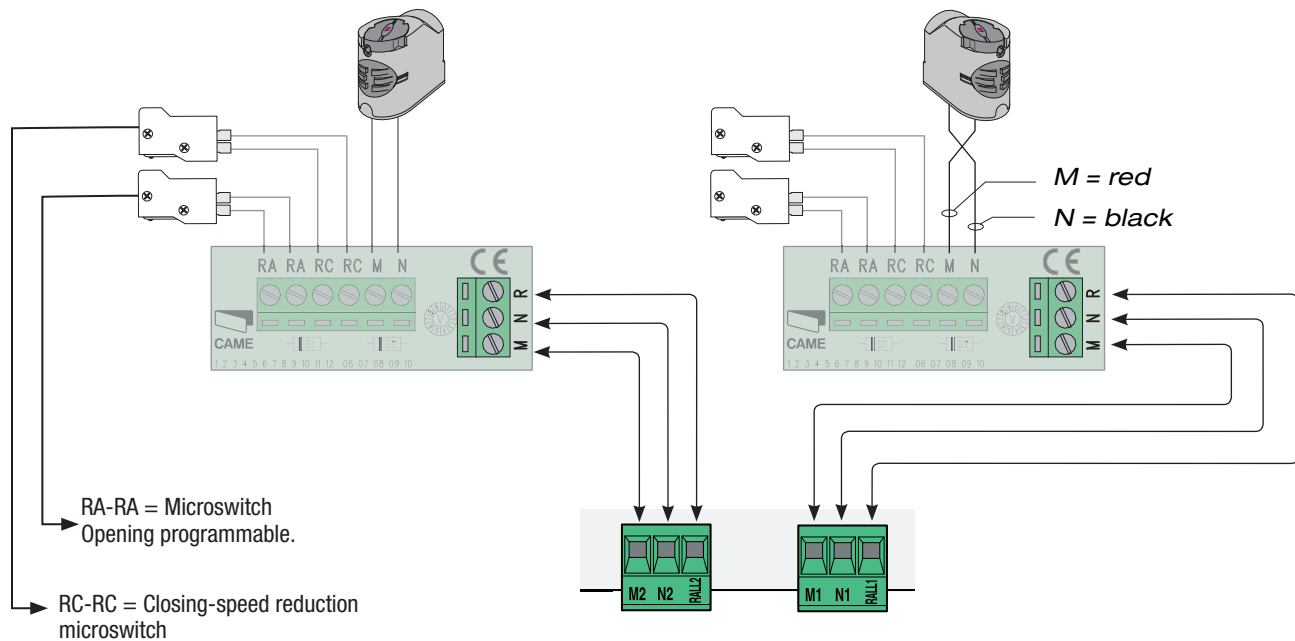

The ZL180 is calibrated to the F7024N or A3024N commands for gate leaves of up to 3 meters.
To command A5024N models (with gate leaves of over 3 m) and reduce peripheral speed, do the following:

- Set dip switches 1 and 6 to ON (and dip switches 2, 3, 4, 5 to OFF);
- press CH1: the red PROG led will start to blink;
- when the led stays on (after about 5 seconds) the procedure is complete;
- set to the dip switches back to OFF (or to the previous position, which depends on the functions selection, see paragraph 7, page 12).

N.B.: to return to default, follow the same procedure while pressing CH2.

CH1 = A5024N

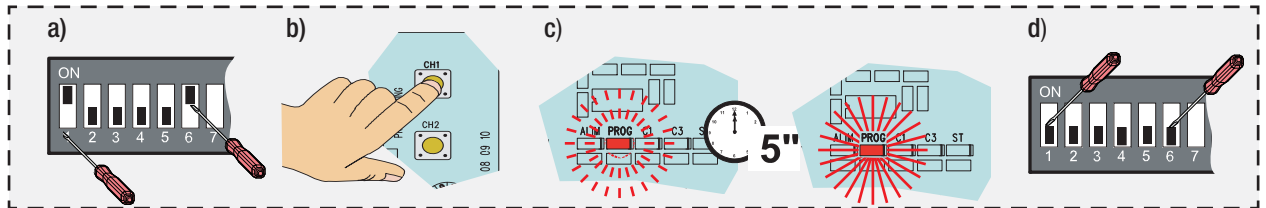

The control panel is set for 2 gearmotors (2 leaved gates).

With only one gearmotor (one-leaved gates; M2 gearmotor), do the following:

- Set dip switches 4 and 6 to ON (and dip switches 1, 2, 3, 5 to OFF);
- press CH1: the red PROG led will start to blink;
- when the led stays on (after about 5 seconds) the procedure is complete;
- set to the dip switches back to OFF (or to the previous position, which depends on the functions selection, see paragraph 7, page 12).

N.B.: to return to default, follow the same procedure while pressing CH2.

CH1 = 1 gate leaf



default

CH2 = 2 gate leaves

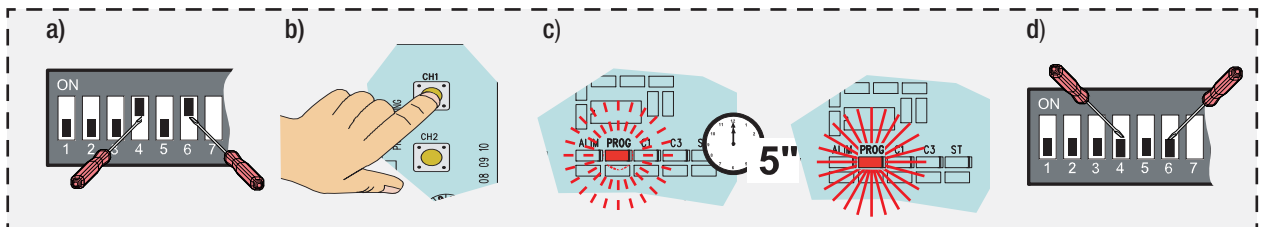

The microswitches on RA terminals, set the opening stop by default.

If you want instead the slowdown in opening is compulsory setback mechanics, follow these steps:

- Set dip switches 5 and 6 to ON (and dip switches 1, 2, 3, 4 to OFF);
- press CH2: the red PROG led will start to blink;
- when the led stays on (after about 5 seconds) the procedure is complete;
- set to the dip switches back to OFF (or to the previous position, which depends on the functions selection, see paragraph 7, page 12).

N.B.: to return to default, follow the same procedure while pressing CH1.

CH2 = Opening slowdown

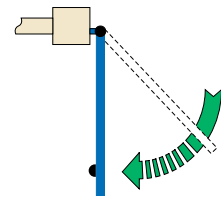

default CH1 = Opening stop

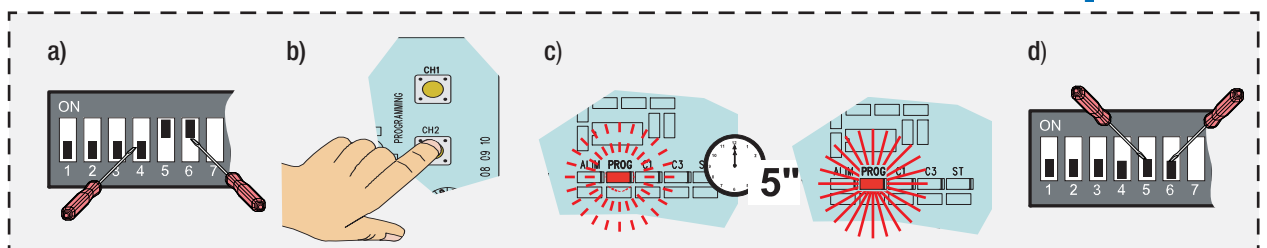
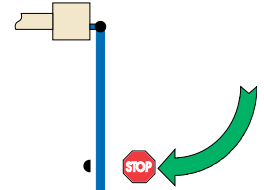

6.5- ELECTRICAL LOCK

ZL180 lets you connect, in two different modes, a 12 V (15 Wmax) electrolock and, if necessary, also activate the “Ram Blow” function.

Mode 1 – Excludes use of the 2nd radio channel on B1-B2; after connecting it, operate as follows:

- Set dip switch 6 to ON (and dip switches 1, 2, 3, 4, 5 to OFF);
- press CH1: the red PROG led will start to blink;
- when the led stays on (after about 5 seconds) the procedure is complete;
- set to the dip switches back to OFF (or to the previous position, which depends on the functions selection, see paragraph 7, page 12).

N.B.: to return to default (2nd radio channel on B1-B2), follow the same procedure while pressing CH2.

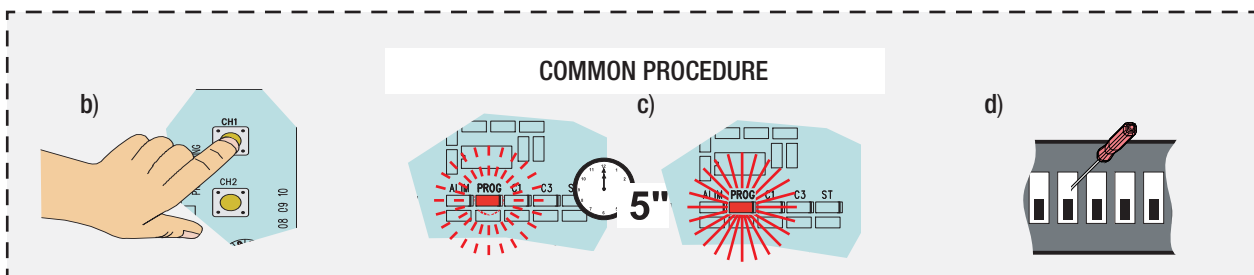
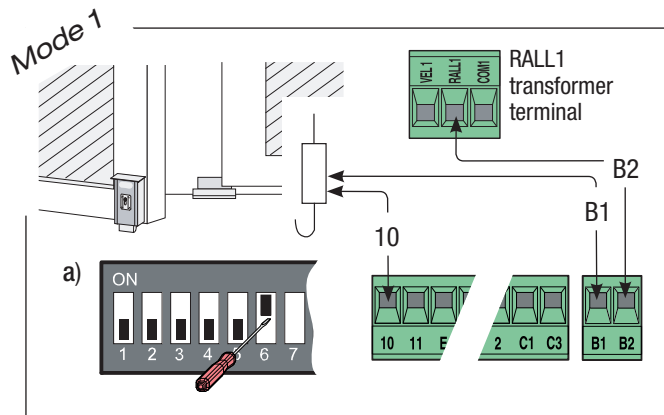

Mode 2 - Does not allow connection of an indicator lamp on 10-5; after connection it:

- Set dip switches 2 and 6 to ON (and dip switches 1, 3, 4, 5 to OFF);
- b), c), d) - continue with the above **COMMON PROCEDURE**.

N.B.: to return to default (indicator lamp on 10-5), follow the same procedure while pressing CH2.

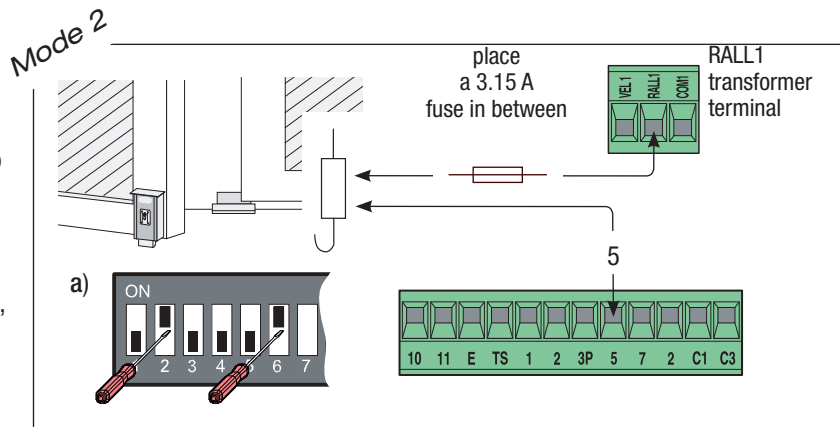

In both modes, to activate the “ram blow” ⁽¹⁾:

- Set dip switches 3 and 6 to ON (and dip switches 1, 2, 4, 5 to OFF);
- b), c), d) - continue with the above **COMMON PROCEDURE**.

N.B.: to exclude the ram blow, follow the same procedure while pressing CH2.

⁽¹⁾ Upon each opening command, the gate leaves press on the closing jamb for one second, assisting the electrolock release operation.

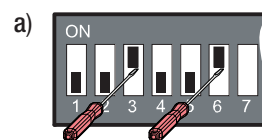

6.6- SAFETY DEVICES

“Partial stop” (N.C.) socket

- input for safety devices such as photocells, sensitive edges and other EN 12978-compliant devices. Halts moving gate leaves and causes them to automatically close

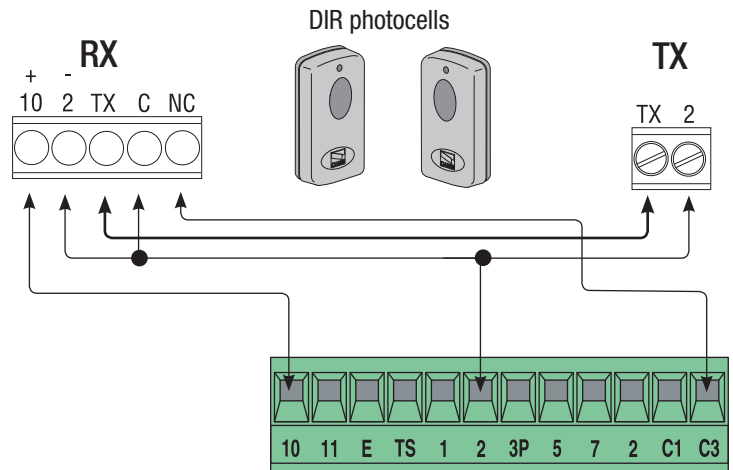

“Open during closing” (N.C.) socket

- Input for safety devices such as photocells, sensitive edges and other EN 12978 compliant devices. When gate leaves are closing, opening the contact causes reversal until total opening is obtained.

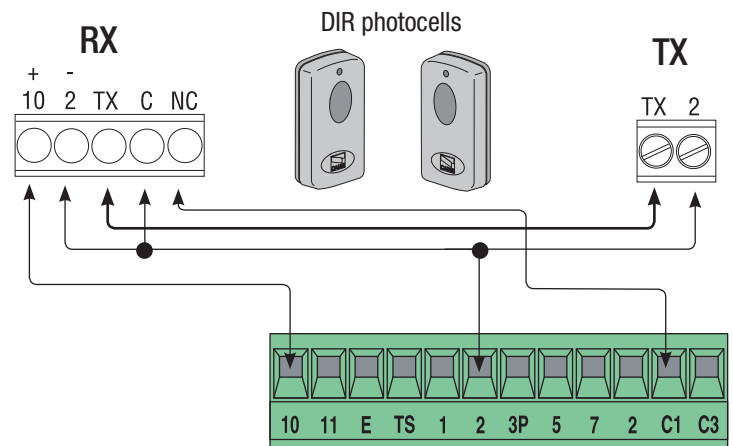

“Partial Stop” (N.C.) socket

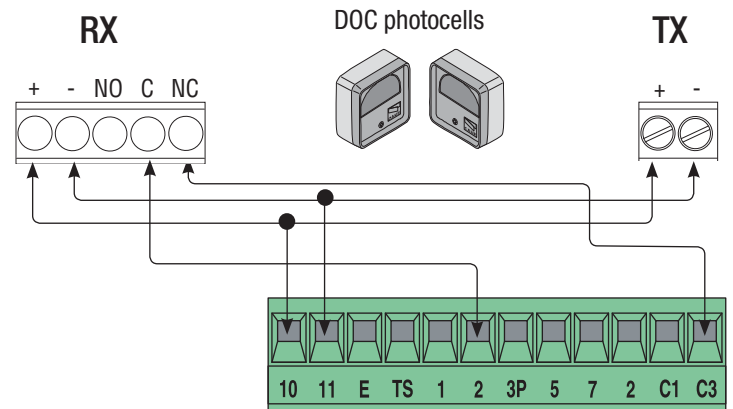

“Open during closing” (N.C.) socket

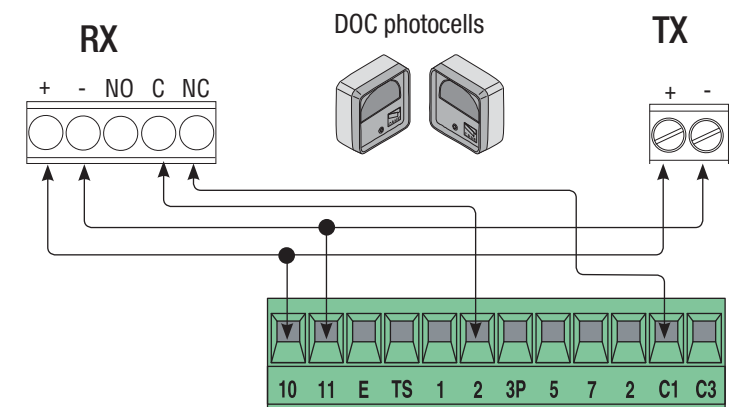

6.7- COMMAND DEVICES

Stop button (N.C. socket)

- Button to stop gate while excluding the automatic closing cycle.
For movement to resume you must press the command button or transmitter button.

Key selector and/or partial opening button (N.O. socket)

- Opening of one gate leaf to allow pedestrian passage.

Key selector and/or commands button (N.O. socket)

- Gate closing and opening contacts, by pressing the button or turning the selector key, the gate movement is inverted or halted depending on which selection was just made. (see selecting functions, dips 2 and 3).

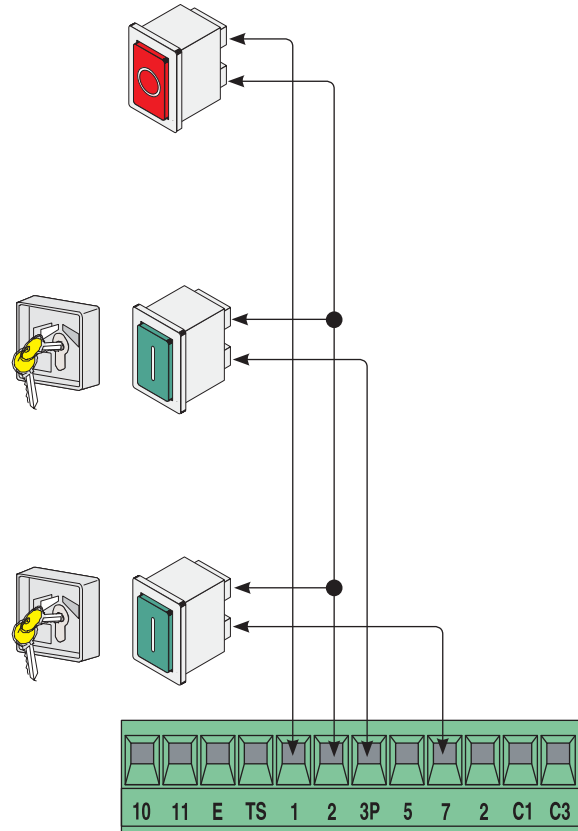

6.8- ELECTRICAL CONNECTION FOR THE PHOTOCELLS FUNCTIONS TEST

(DOC)

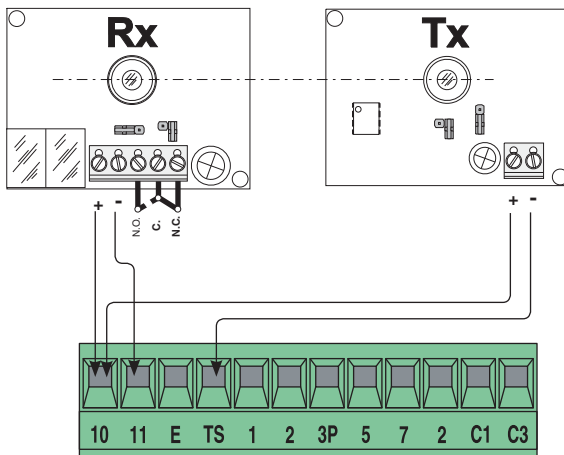

(DIR)

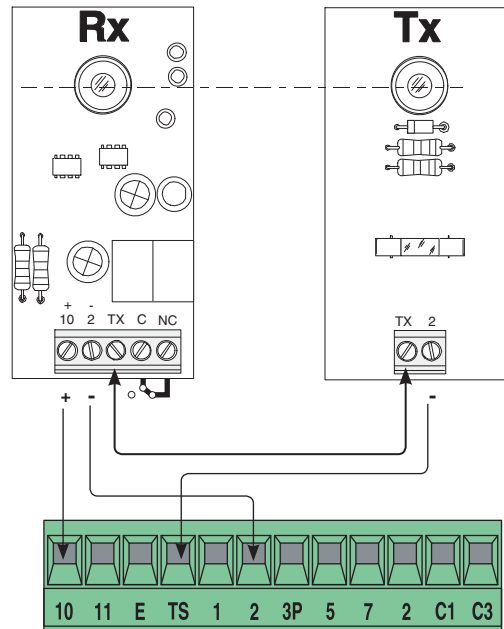

At each opening and closing command, the control board assesses the efficiency status of the control devices (photocells). Any anomaly found is signalled with the flashing of the (PROG) LED on the control panel. Consequently it cancels any commands coming from the remote control or the button.

Electrical connection to enable the photocell safety test:

- the transmitter and the receiver, must be connected as per the diagram;
- set DIP switch 9 to ON to activate test operation.

IMPORTANT:

when running the safety test function, the N.C. contacts, if unused, should be excluded on the relative DIP switches (see chapter 7 "selecting functions").

7 Selecting functions

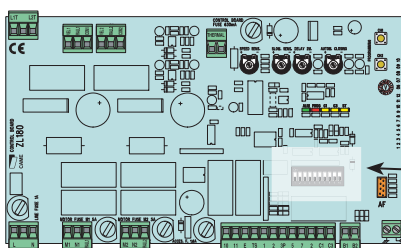

DIP-SWITCH

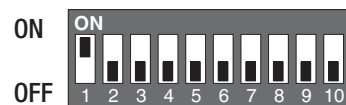

- 1 ON - Automatic closing - the automatic closing timer is activated when on opening the gate leaf has reached the full open stroke. The time is preset and adjustable, and is subject to the action of any safety devices. It does not activate after a total safety "stop" or during a power outage;
- 2 ON - "Open-stop-close-stop" function with button [2-7] and remote control (with built-in radiofrequency card);
- 2 OFF - "Open-close" function with button [2-7] and remote control (with built-in radiofrequency card);
- 3 ON - "Open only" function with button [2-7] and remote control (with built-in radiofrequency card);
- 4 ON - Pre-Flashing during opening and closing - Following an opening or closing command, the flasher connected to [10-E], flashes for 5 seconds before initiating the operation;
- 5 ON - Obstacle detection - When motor is idle (gate closed, open or after a total stop command), it prevents any motion if the safety devices (e.g. photocells) detect any obstacle;
- 6 ON - Maintained action - the gate works by keeping the button pressed (one button [2-3P] for opening, and one button [2-7] for closing);
- 7 OFF - Reopening during closing - if the photocells detect an obstacle during gate closing, the gate motion is inverted until total opening is reached; connect the safety device to terminals [2-C1]; sif not used, set DIP switch to ON;
- 8 OFF - Partial stop - stops gate when an obstacle is detected by the safety devices; once the obstacle is cleared, the gate remains still or closes if the automatic closing function is enabled. Connect the safety devices to terminal [2-C3]; sif not used, set DIP switch to ON.
- 9 ON - Operation of the photocells safety test - this allows the card to assess the efficiency of the safety devices (photocells) after each opening and closing command;
- 10 ON - Reaction time - Increases to 2" the running time of the movement inversion function, controlled by the amperometric sensor.

NB – Dip switches 1 through 6 are used, independently, also for the gearmotor and electroloc connection options (pages 7-8-9).

8 Trimmers adjustment

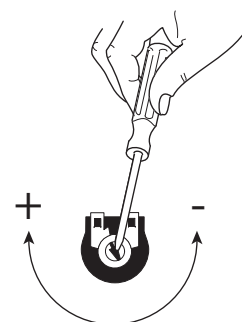
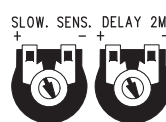
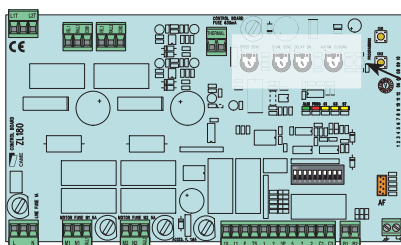

- «SPEED SENS.» Adjusts the amperometric sensitivity which controls the power developed by the motor during motion; if the power exceeds the adjusted level, the system sets in motion to invert the direction of motion.
- «SLOW.SENS.» Adjusts the amperometric sensitivity which controls the power developed by the motor during slowing downs; if the power exceeds the adjusted level, the system sets in motion to invert the direction of motion.
- «DELAY 2M» Adjusts the waiting time of the second motor during each closing run. The waiting time can be adjusted anywhere between 1 and 17 seconds.
- «AUTOM. CLOSING» Adjusts the waiting time when gate is open. Once this time has elapsed, the gate closes automatically. The waiting time can be adjusted anywhere between 1 and 150 seconds.

9 Adjusting the endstops

ATI gearmotors

Adjustments to carry out when gearmotors are in release mode: insert the release key and turn it clockwise.

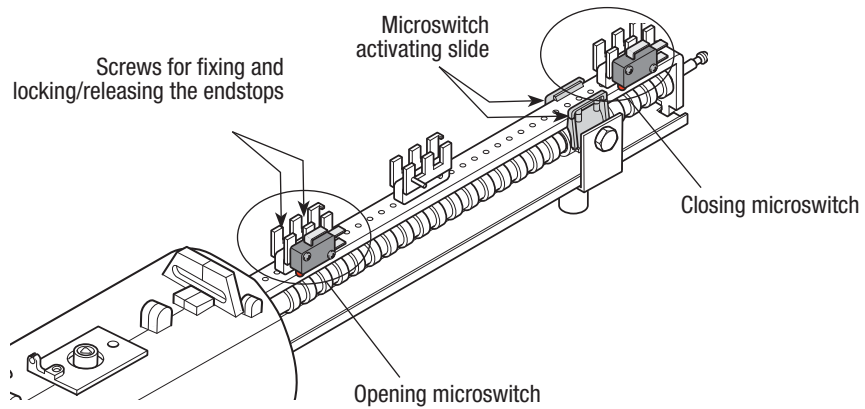
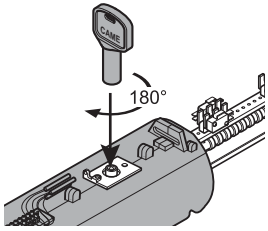

- OPENING ENDSTOP - ATI gearmotors

Depending on the function you have assigned to the opening endstop (see paragraph 6.4, page 7) the adjustment settings will be the following:

Opening Stop (default function)

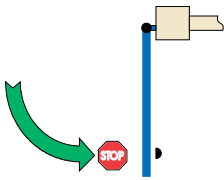

- If it intervenes resulting in a Stop,
- manually push the door to the fully opened position;
 - release or detach the endstop and slide it or reposition it **until the switch is activated** as shown in the drawing;
 - lock the assembly in this position.

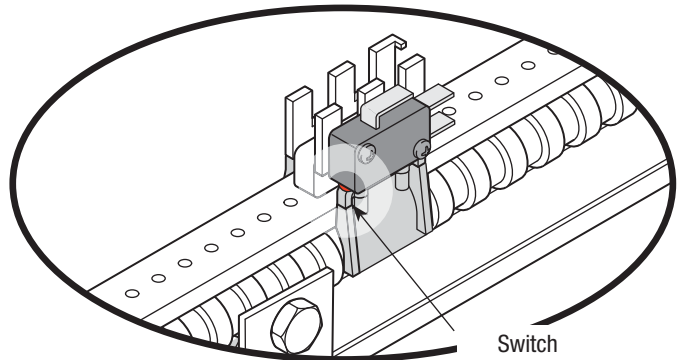

Switch

Opening deceleration (option)

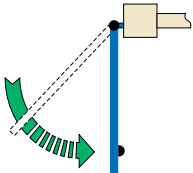

However, if it intervenes activating the Deceleration mode,

- manually push the door to the fully opened position;
- release or detach the endstop and slide it or reposition it so **that the switch is adjacent to the slide** as shown in the drawing;
- lock the assembly in this position.

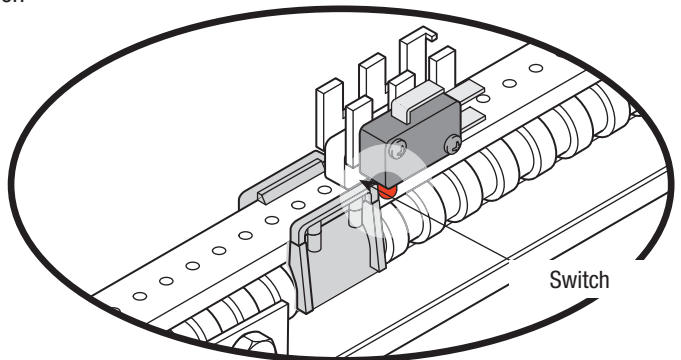

Switch

- CLOSING ENDSTOP - ATI gearmotors

The closing endstop only activates the deceleration.

Closing deceleration

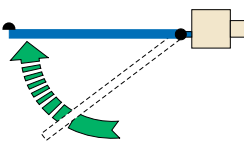

- To adjust the microswitch,
- manually push the gate leaf to the fully closed position;
 - release or detach the endstop and slide it or reposition it so **that the switch is adjacent to the slide** as shown in the drawing;
 - lock the assembly in this position.

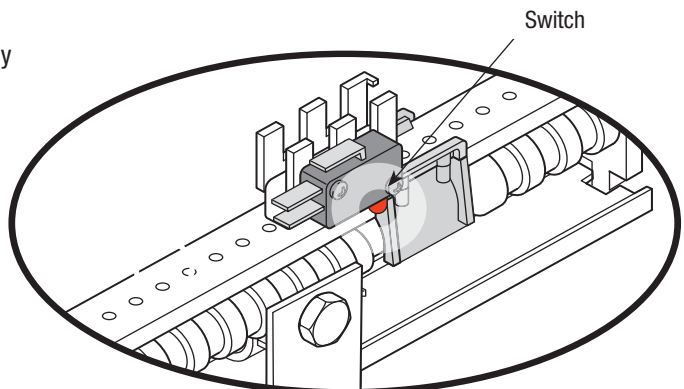

Switch

FAST gearmotors

WARNING! Make sure you have inverted the M-N connection for **THE RIGHT-HAND MOTOR**, as shown on page 8.

Adjustments to carry out when gearmotors are released: insert the release handle and turn it counter-clockwise.

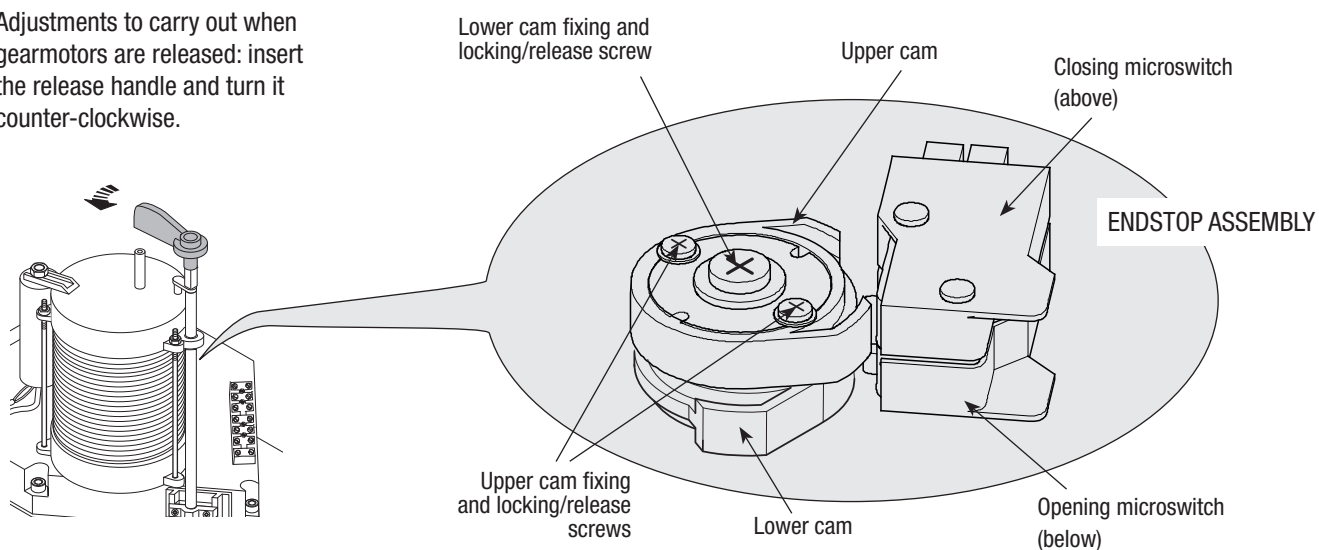

- SWITCHES OPENING - MOTOR LEFT (INSIDE VIEW)

Depending on the function you have assigned to the opening endstop (see paragraph 6.4, page 7) the adjustment settings will be the following:

With the motor released, place the gate leaf at a distance of 5 cm from the opening endstop.

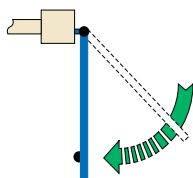

Rotate the lower cam clockwise until the microswitch is activated.

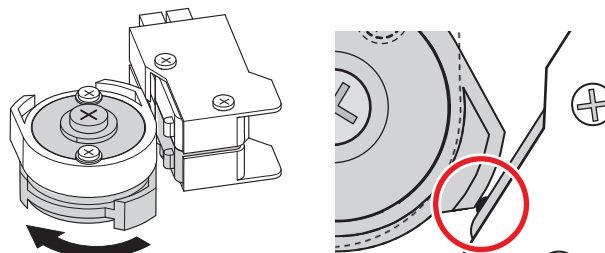

Secure the cam using the central screw.

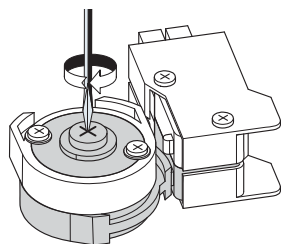

CLOSING ENDSTOP – LEFTHAND GEARMOTOR (INSIDE VIEW)

N.B. The closing endstop can be adjusted after setting the opening microswitch.

Warning: the upper cam of the operator's endstop assembly is calibrated for gate widths of between 1.2 m to 2.2 m.

- Release the gearmotor and fully close the gate leaf.

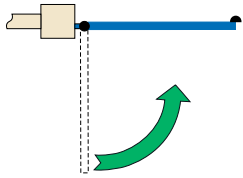

- turn the lower cam counter-clockwise, until the micro switch is released.

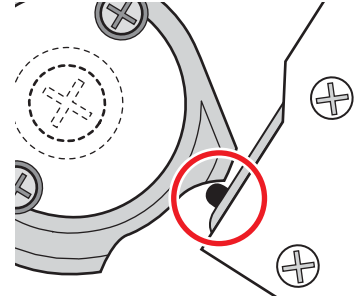
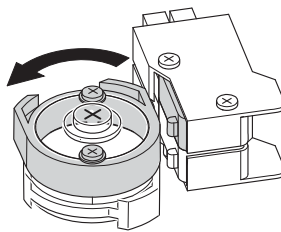

- Secure the cam by tightening the lateral screws.

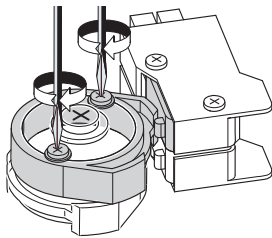

LEFTHAND GEARMOTOR – INSIDE VIEW

If the gate leaf measures less than 1.2 m, you must turn the upper cam upside down and then set the microswitch.

- Remove the screws from the upper cam and turn it upside down.

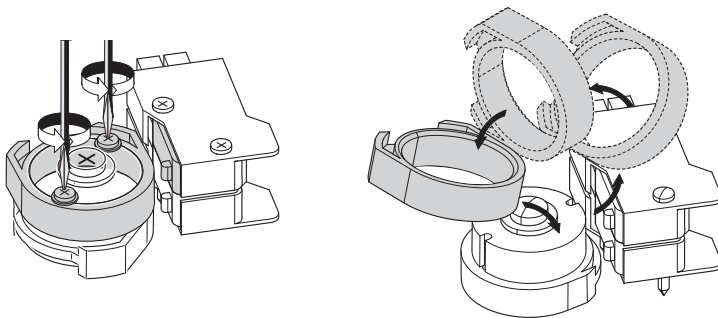

Release the gearmotor and fully close the gate leaf.

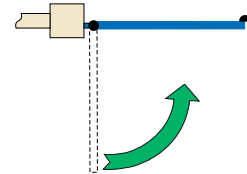

- turn the lower cam counter-clockwise, until the micro switch is released.

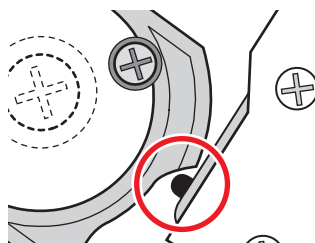
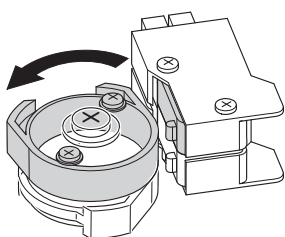

- Secure the cam by tightening the lateral screws.

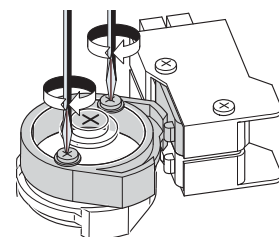

- OPENING ENDSTOP – RIGHTHAND GEARMOTOR – INSIDE VIEW

- Remove the screws from the upper cam and turn it upsidedown.

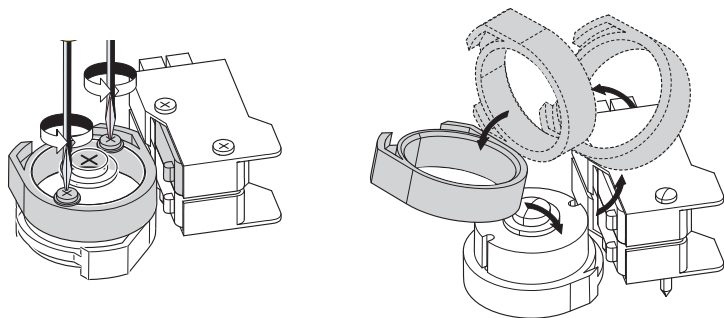

- Release the motor and position the gate leaf 5 cm ajar from the opening endstop

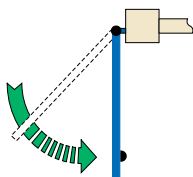

Turn the lower cam counter-clockwise, until the microswitch is engaged.

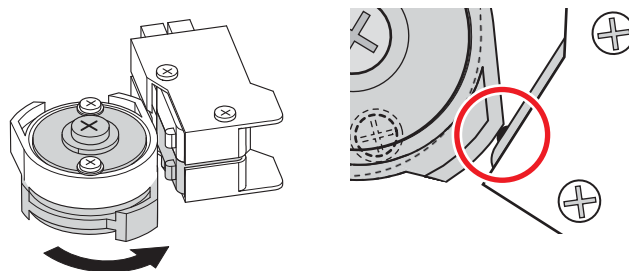

- Secure the cam by tightening the central screw.

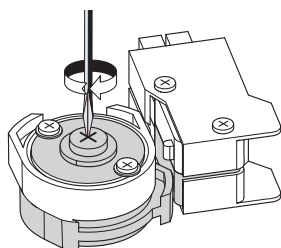

CLOSING ENDSTOP – RIGHTHAND GEARMOTOR – INSIDE VIEW

N.B. Always first adjust the opening endstop and then the closing endstop

Warning: the upper cam of the operator's endstop assembly is calibrated for gate widths of between 1.2 m to 2.2 m.

- Release the gearmotor and fully close the gate leaf.

- turn the upper cam clockwise, until the micro switch is released.

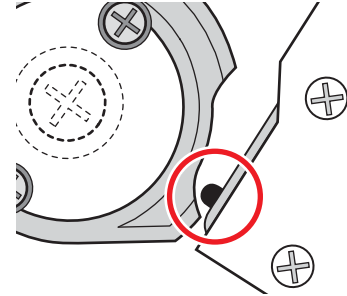
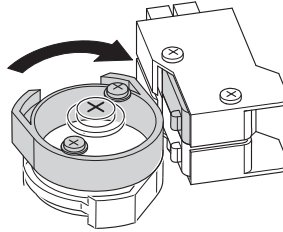
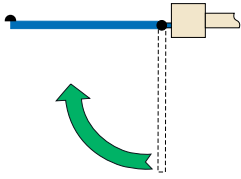

- Secure the cam by tightening the lateral screws.

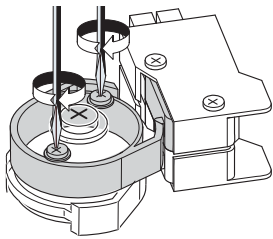

RIGHTHAND GEARMOTOR – INSIDE VIEW

If the gate leaf measures less than 1.2 m, you must turn the upper cam upside down and then set the microswitch.

- Remove the screws from the upper cam and turn it upside down.

- Release the gearmotor and fully close the gate leaf.

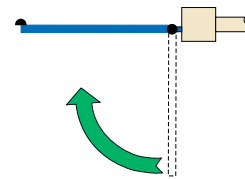
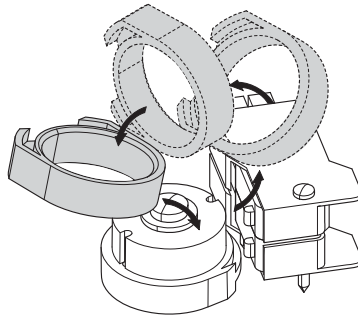
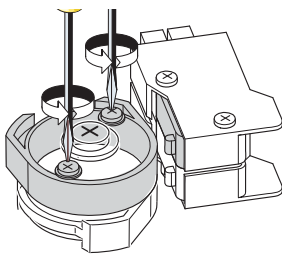

- turn the upper cam clockwise, until the micro-switch is released.

- Secure the cam by tightening the lateral screws.

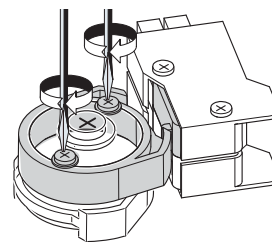
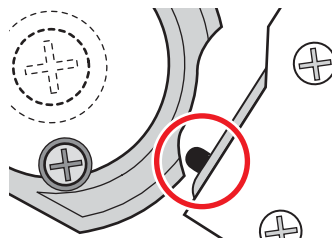
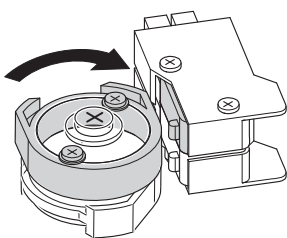

10 Signal LED

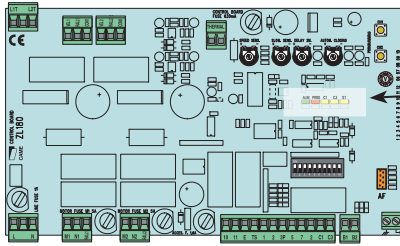

LIST OF CONTROL LED SIGNALS OF THE COMMAND AND SAFETY DEVICES:

- «ALIM» Green LED. Normally on, because it signals the cards proper power rate.
- «PROG» Red LED. Normally off.
During the remote control's activation procedure, it turns on and blinks.
It blinks faster when combined with LEDs C1/C3/ST
- «C1» Yellow LED. Normally off.
When it is on and with the PROG LED blinking it warns of objects detected by the photocells (connected to REOPEN DURING CLOSING) or non-operation of the same.
- «C3» Yellow LED. Normally off.
When it is on and with the PROG LED blinking it warns of objects detected by the photocells (connected to PARTIAL STOP) or non-operation of the same.
- «ST» Yellow LED. Normally off.
When it is on and with the PROG LED blinking it means the TOTAL STOP button has been pushed, or non-operation of the same.

11 Activating the remote control

11.1 - ANTENNA

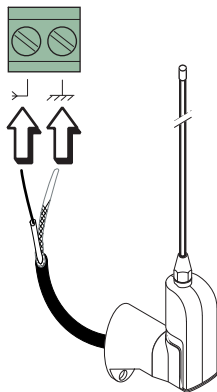

Connect the antenna's RG58 cable to the apposite terminals.



Possible output of the radio receiver's second channel (N.O. socket).
Socket rating: 5 A-24 V DC.
(Also see Chapt. 6.5)

11.2 - RADIOFREQUENCY CARD

Lock the radiofrequency card into the electronic card AFTER CUTTING OFF THE POWER SUPPLY (or after disconnecting the batteries).
N.B.: the electronic card only recognises the radiofrequency card when the power is on.

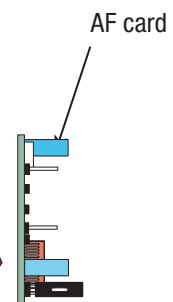
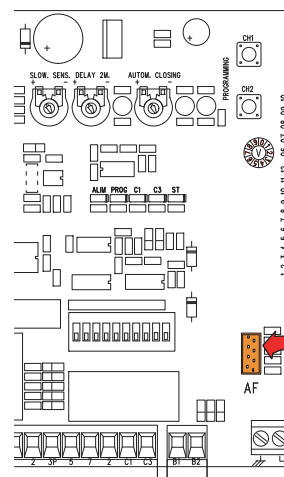

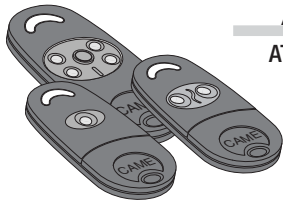

ATOMO
AT01 • AT02
AT04

See instructions attached to AF43SR radiofrequency card

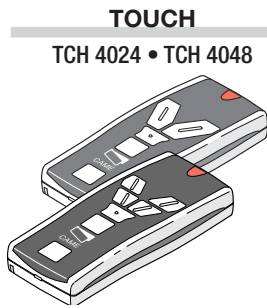

TOUCH
TCH 4024 • TCH 4048

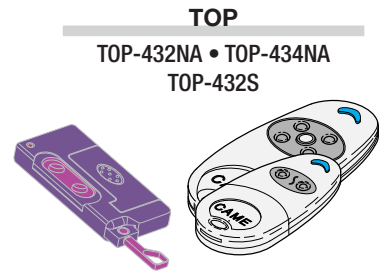

TOP
TOP-432NA • TOP-434NA
TOP-432S

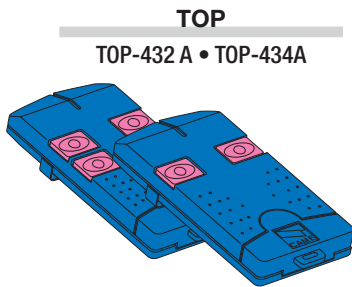

TOP
TOP-432 A • TOP-434A

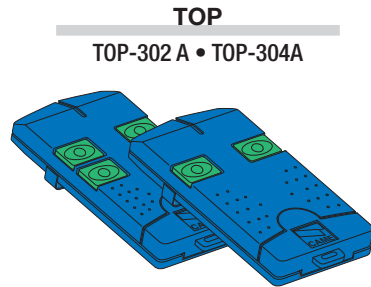

TOP
TOP-302 A • TOP-304A

See attached instructions

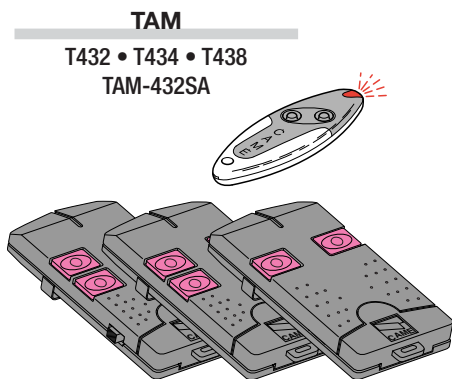

TAM
T432 • T434 • T438
TAM-432SA

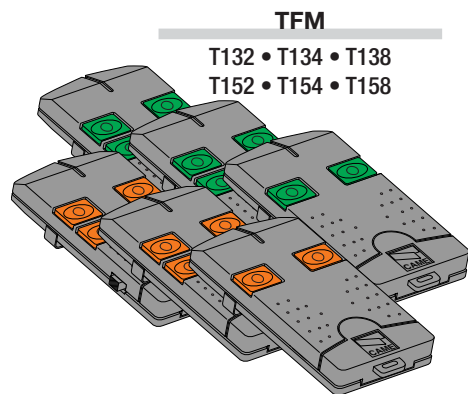

TFM
T132 • T134 • T138
T152 • T154 • T158

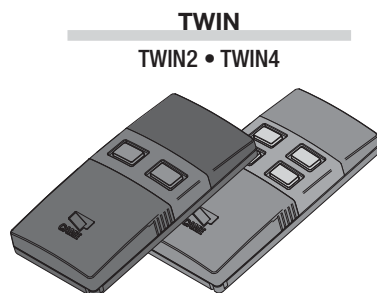

TWIN
TWIN2 • TWIN4

11.4 - MEMORISATION

CH1 = Channel for direct command to a function of the the gearmotor's card, ("open only / "open-close-invert" or "open-stop-close-stop" command, depending on the choice made on DIP switches 2 and 3).

CH2 = Channel for direct command an accessory device connected to B1-B2.

1) Keep the CH1 button on the electronic card pressed. The LED flashes.

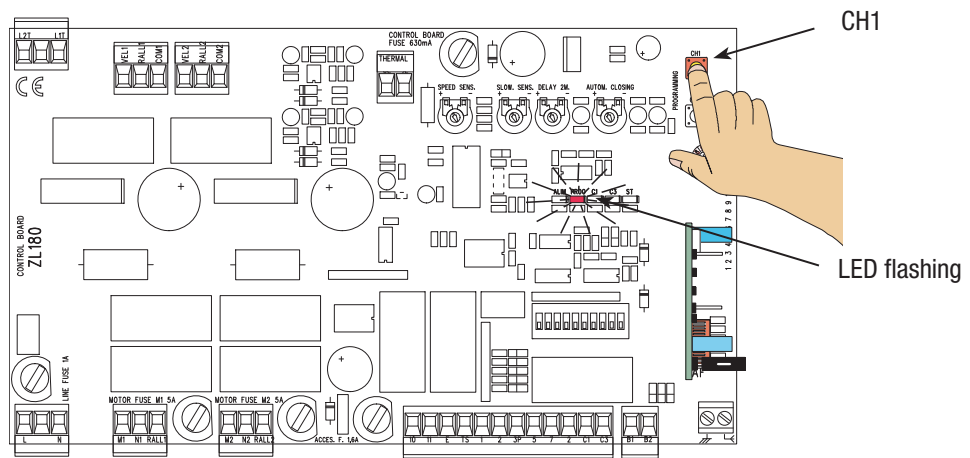

2) Press the transmitter button you wish to memorise. The LED will stay on to show memorisation has been successful.

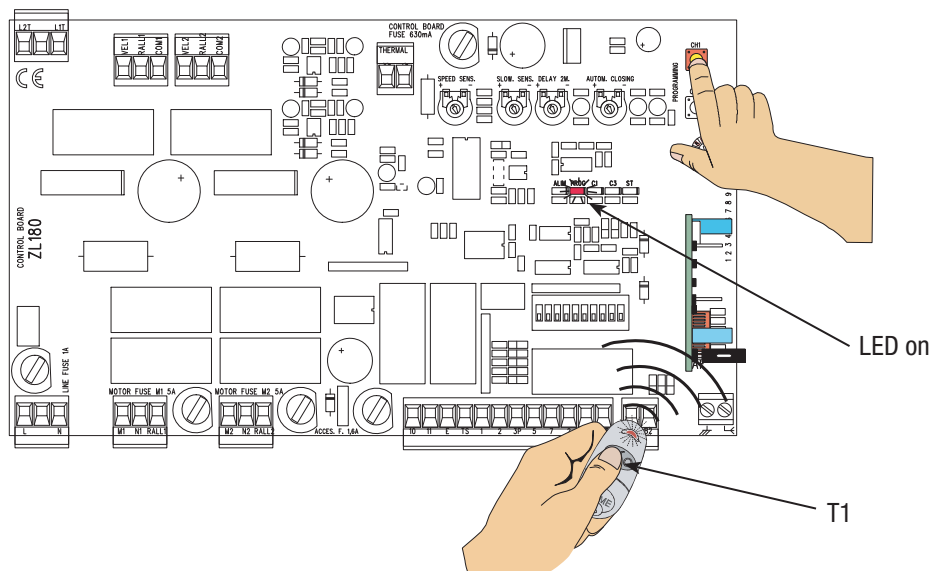

3) Repeat the points 1 and 2 procedures for the "CH2" button associating this to another button on the transmitter.

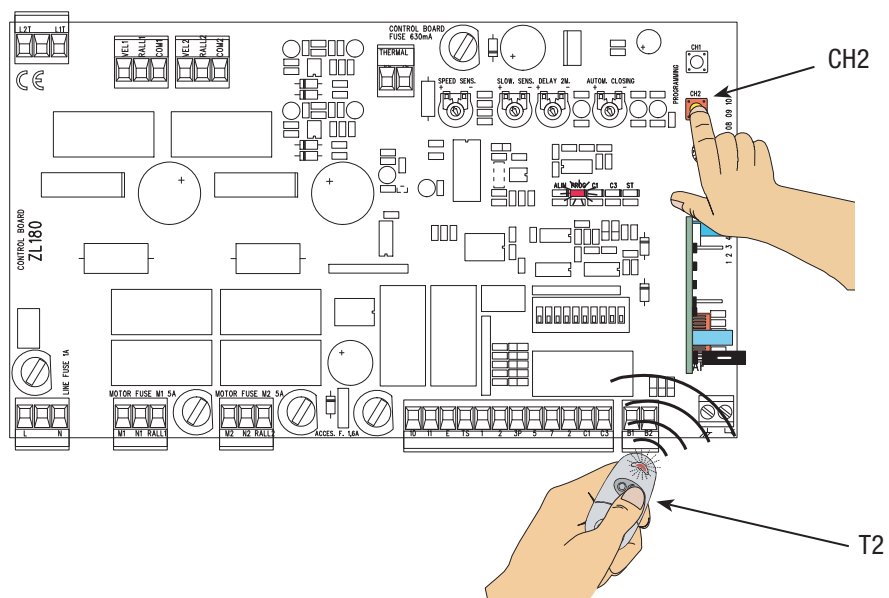

12 Phasing out and disposal



Our products are made with different types of materials. The majority of these (aluminium, plastic, iron and electrical cables) are part of the solid urban waste category. They can be recycled through licensed waste disposal plants.



Other components (electronic cards, remote control batteries, etc.) constitute hazardous waste. Thus, they are to be removed and delivered to licensed firms that specialise in their proper disposal.

ENGLISH

13 Conformity declaration



CAME Cancelli Automatici S.p.A.
via Martiri della Libertà, 15
31030 Dosson di Casier - Treviso - ITALY
tel (+39) 0422 4940 - fax (+39) 0422 4941
internet: www.came.it - e-mail: info@came.it

Declares under its own responsibility that the equipments for automatic garage doors and gates listed below:
CONTROL PANELS FOR SWING GATES

ZL180

... comply with the National Law related to the following European Directives and to the applicable parts of the following Standards.

2006/95/EC Low VOLTAGE DIRECTIVE
2004/108/EC ELECTROMAGNETIC COMPATIBILITY DIRECTIVE

EN 60335-1 EN 61000-6-2
EN 60335-2-103 EN 61000-6-3
EN 13241-1

EC DECLARATION OF CONFORMITY

Pursuant to the Low Voltage Directive 2006/95/CE

IMPORTANT WARNING!

Do not use the equipment specified here above, before completing the full installation in full compliance to the Low Voltage Directive 2006/95/CE

MANGING DIRECTOR
Mr. Gianni Michielan

Codice di riferimento per richiedere una copia conforme all'originale: **DDF L EN Z002f**

THIS PAGE LEFT INTENTIONALLY BLANK

CAME France S.a. 7, Rue Des Haras Z.i. Des Hautes Patures 92737 Nanterre Cedex ☎ (+33) 1 46 13 05 05 📠 (+33) 1 46 13 05 00	FRANCE	GERMANY	CAME Gmbh Kornwestheimer Str. 37 70825 Korntal Munchingen Bei Stuttgart ☎ (+49) 71 5037830 📠 (+49) 71 50378383
CAME Automatismes S.a. 3, Rue Odette Jasse 13015 Marseille ☎ (+33) 4 95 06 33 70 📠 (+33) 4 91 60 69 05	FRANCE	GERMANY	CAME Gmbh Seefeld Akazienstrasse, 9 16356 Seefeld Bei Berlin ☎ (+49) 33 3988390 📠 (+49) 33 39883985
CAME Automatismos S.a. C/juan De Mariana, N. 17-local 28045 Madrid ☎ (+34) 91 52 85 009 📠 (+34) 91 46 85 442	SPAIN	U.A.E.	CAME Gulf Fze Office No: S10122a2o210 P.O. Box 262853 Jebel Ali Free Zone - Dubai ☎ (+971) 4 8860046 📠 (+971) 4 8860048
CAME United Kingdom Ltd. Unit 3 Orchard Business Park Town Street, Sandiacre Nottingham - Ng10 5bp ☎ (+44) 115 9210430 📠 (+44) 115 9210431	GREAT BRITAIN	RUSSIA	CAME Rus Umc Rus Lic Ul. Otradnaya D. 2b, Str. 2, office 219 127273, Moscow ☎ (+7) 495 739 00 69 📠 (+7) 495 739 00 69 (ext. 226)
CAME Group Benelux S.a. Zoning Ouest 7 7860 Lessines ☎ (+32) 68 333014 📠 (+32) 68 338019	BELGIUM	CHINA	CAME (Shanghai) Automatic Gates Co. Ltd. 1st Floor, Bldg 2, No. 1755, South Hongmei Road Shanghai 200237 ☎ (+86) 021 61255005 📠 (+86) 021 61255007
CAME Americas Automation Lic 11405 NW 122nd St. Medley, FL 33178 ☎ (+1) 305 433 3307 📠 (+1) 305 396 3331	U.S.A	PORTUGAL	CAME Portugal Ucj Portugal Unipessoal Lda Rua Júlio Dinis, N. 825, 2esq 4050 327 Porto ☎ (+351) 915 371 396

English - Manual code: 319U17 ver. 1.2 04/2010 © CAME cancelli automatici s.p.a.
 The data and information reported in this installation manual are susceptible to change at any time and without obligation on CAME cancelli automatici s.p.a. to notify users.

CAME Cancelli Automatici S.p.a. ITALY
 Via Martiri Della Libertà, 15
 31030 **Dosson Di Casier** (Tv)
 ☎ (+39) 0422 4940
 📠 (+39) 0422 4941
 Informazioni Commerciali 800 848095

ITALY

CAME Sud s.r.l.
 Via F. Imperato, 198
 Centro Mercato 2, Lotto A/7
 80146 **Napoli**
 ☎ (+39) 081 7524455
 📠 (+39) 081 7529190

CAME Service Italia S.r.l. ITALY
 Via Della Pace, 28
 31030 **Dosson Di Casier** (Tv)
 ☎ (+39) 0422 383532
 📠 (+39) 0422 490044
Assistenza Tecnica 800 295830