

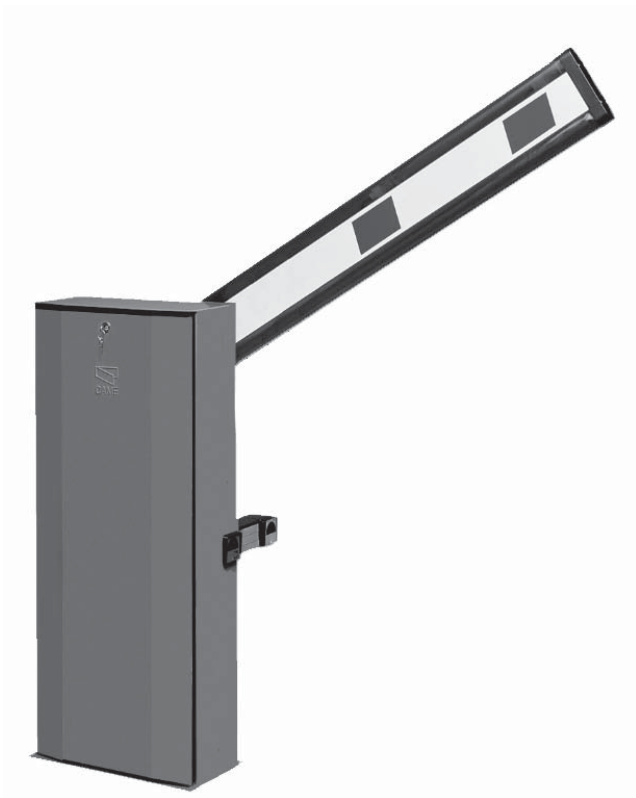

CE

119G26EN

STREET BARRIER
AUTOMATION



INSTALLATION MANUAL

G6000 - G6001



English

EN



WARNING!

Important instructions for the safety of people:

READ CAREFULLY!



Foreword

• Use of the products must be restricted to its intended use (i.e. that for which it was expressly built for). Any other use is to be considered dangerous. Came Cancelli Automatici S.p.A. is not liable for any damage resulting from improper, wrongful or unreasonable use • Keep these warnings with the installation and use manuals issued with the automated system.

Before installing

(preliminary check: in case of a negative outcome, do not proceed before having complied with the safety obligations)

• Make sure that the parts you intend to automate are in good working order, and that they are properly balanced and aligned. Also, make sure that proper mechanical stops are already in place • If the operator will be installed at a height of less than 2.5 m from the ground or other access level, check whether you will need any protections and/or warnings • Any gate leaves, fitted with pedestrian entrances, onto which you will install an operator, must have a blocking mechanism when the gate is in motion • Make sure that the opening of the automated gate is not an entrapment hazard as regards any surrounding fixed parts • Do not mount the operator upside down or onto any elements that may fold under its weight. If needed, add suitable reinforcements at the points where it is secured • Do not install onto gates on either an upward or downward slope (i.e. that are not on flat, level ground) • Check that any lawn watering devices will not wet the gearmotor from the bottom up.

Installation

• Carefully section off the entire site to prevent unauthorised access, especially by minors and children • Be careful when handling operators that weigh more than 20 Kg (see installation manual). In such cases, employ proper weight handling safety equipment • All opening commands (e.g. buttons, key selectors, magnetic detectors, etc.) must be installed at least 1.85 m from the gate's area of operation perimeter - or where they cannot be reached from the outside of the gate. Also, the direct commands (e.g. push button, or proximity devices, etc.) must be installed at a height of at least 1.5 m and must not be accessible to the public • All 'maintained action' commands, must be placed where the moving gate leaves, transit areas and driveways are completely visible • If missing, apply a permanent label that shows the position of the release mechanism • Before delivering to the client, verify that the system is EN 12453 (impact test) standard compliant. Make sure that the operator has been properly adjusted and that the safety and protection devices, as well as the manual release

are working properly • Where necessary and in plain sight, apply the Warning Signs (e.g. gate plate).

Special instructions and advice for users

• Keep the gate's area of operation clean and clear of any obstacles. Trim any vegetation that may interfere with the photocells • Do not allow children to play with the fixed command devices, or in the gate's area of operation. Keep any remote control devices (i.e. transmitters) away from the children as well • Frequently check the system, to see whether any anomalies or signs of wear and tear appear on the moving parts, on the component parts, on the securing points, on the cables and any accessible connections. Keep any joints (i.e. hinges) lubricated and clean, and do the same where friction may occur (i.e. slide rails) • Perform functional tests on photocells and sensitive edges, every six months. Keep glass panels constantly clean (use a slightly water-moistened cloth; do not use solvents or any other chemical products) • If the system requires repairs or modifications, release the operator and do not use it until safety conditions have been restored • Cut off the power supply before releasing the operator for manual openings. See instructions • Users are FORBIDDEN to carry out ANY ACTIONS THAT THEY HAVE NOT BEEN EXPRESSLY ASKED TO DO OR SO INDICATED in the manuals. Any repairs, modifications to the settings and extraordinary maintenance MUST BE DONE BY THE TECHNICAL ASSISTANCE STAFF • On the periodic maintenance log, note down the checks you have done.

Special instructions and advice for all

• Avoid working near the hinges or moving mechanical parts • Stay clear of the gate's area of operation when in motion • Do not resist the direction of movement of the gate; this may present a safety hazard • At all times be extremely careful about dangerous points that must be indicated by proper pictograms and/or black and yellow stripes • When using a selector or command in 'maintained action' mode, keep checking that there are no people in the area of operation of the moving parts. Do this until you release the command • The gate may move at any time without warning • Always cut the power when cleaning performing maintenance.



Came Cancelli Automatici s.p.a.

address Via Martiri della Libertà Street n. 15 postal code 31030
location Dosson di Casier province Treviso state Italia

DECLARES THAT THE PARTLY COMPLETED MACHINERY

AUTOMATIC ROAD BARRIERS

G2080Z; G2080IZ; G2081Z; G2080E; G2080IE
G4040Z; G4040IZ; G4041Z; G4040E; G4040IE
G2500; G2500N; G2510;
G3250; G3750; G3751;
G3000DX; G3000SX; G3000IDX; G3000ISX;
G4000; G4000C; G4000D; G4000E; G4000N; G4001; G4001E; G4010; G4011;
G6000; G6000B; G6000E; G6001; G6001E; G6010; G6011;
G6500; G6501;
G12000; G12000A; G12000S
G02040; G04060; G06080
G02801; G02803;
G03755DX; G03755SX

MEET THE APPLICABLE ESSENTIAL REQUIREMENTS

1.1.3 - 1.1.5 - 1.2.1 - 1.2.2 - 1.3.2 - 1.3.7 - 1.3.8.1 - 1.4.1 - 1.4.2 - 1.4.2.1 - 1.5.1 - 1.5.6 - 1.5.8 -
1.5.9 - 1.5.13 - 1.6.1 - 1.6.3 - 1.6.4 - 1.7.1 - 1.7.2 - 1.7.4

COMPLIES WITH THE PROVISIONS OF THE FOLLOWING DIRECTIVES

DIRECTIVE 2006/42/EC OF THE EUROPEAN PARLIAMENT AND OF THE COUNCIL
of 17 May 2006 on machinery, and amending Directive 95/16/EC.

DIRECTIVE 2004/108/EC OF THE EUROPEAN PARLIAMENT AND OF THE COUNCIL
of 15 December 2004 on the approximation of the laws of the Member States relating to electromagnetic compatibility.

PERSON AUTHORISED TO COMPILE THE RELEVANT TECHNICAL DOCUMENTATION

Came Cancelli Automatici s.p.a.

address Via Martiri della Libertà Street n. 15 postal code 31030
location Dosson di Casier province Treviso state Italia

The pertinent technical documentation has been drawn up in compliance with attached document IIB

Came Cancelli Automatici S.p.A., following a duly motivated request from the national authorities, undertakes to provide information related to the quasi machines,

and FORBIDS

commissioning of the above mentioned until such moment when the final machine into which they must be incorporated, has been declared compliant, if pertinent, to 2006/42/CE.

Dosson di Casier (TV)
26 march 2012

Gianni Michielan
Managing Director

DDI BEN **G001b** ver. 4.2 01 February 2011
Translation of the Declaration in the original language

Came Cancelli Automatici s.p.a.

Via Martiri della Libertà, 15 - 31030 Dosson di Casier - Treviso - Italy - Tel. (+39) 0422 4940 - Fax (+39) 0422 4941
info@came.it - www.came.com

Cap. Soc. 1.610.000,00 € - C.F. e P.I. 03481280265 - VAT IT 03481280265 - REA TV 275359 - Reg Imp. TV 03481280265

“IMPORTANT SAFETY INSTRUCTIONS FOR INSTALLATION”

“CAUTION: IMPROPER INSTALLATION MAY CAUSE SERIOUS DAMAGE, FOLLOW ALL INSTALLATION INSTRUCTIONS CAREFULLY”

“THIS MANUAL IS ONLY FOR PROFESSIONAL INSTALLERS OR QUALIFIED PERSONS”

1 Legend of symbols

This symbol indicates sections to be read with particular care.

This symbol indicates sections concerning safety.

This symbol indicates notes to communicate to users.

2 Destination and limits of use

2.1 Destination

The GARD automatic barrier was designed for use in private or public car parks, in residential areas or in highly trafficked areas.



The use of this product for purposes other than as described above and installation executed in a manner other than as instructed in this technical manual are prohibited.

2.2 Limits of use

Opening up to 6.5 meters (with accessories up to 6 m) with opening cycle of between 4 to 8 seconds.

3 Standard followed

Came Cancelli Automatici is ISO 9001 and ISO 14001 Quality and Environmentally certified. Came entirely designs and manufactures its products in Italy. The product in question compliant to the following legislation: *see Declaration of Compliance*.

4 Description

4.1 Gearmotor

GARD automation was designed and manufactured by CAME CANCELLI AUTOMATICI S.p.A. and is compliant with safety regulations in force.

There are two versions of the GARD model:

G6000 - barrier with 24V D.C. irreversible gearmotor, with galvanised, varnished steel cabinet, plus inboard command and control panel;

G6001 - Version with stainless steel cabinet.

NB - You must request right or left-side barriers when ordering. In this manual only left-hand barriers are shown.

Required accessories:

G0601 - White varnished aluminium boom, 100x40 mm, L = 6850 mm;

G0602 - Tube-shaped white varnished aluminium boom, with Ø100 mm, L = 6850 mm (Accessory specific for very windy zones);

G0605 - Attachment for the G0602 tube boom.

Optional accessories:

G0603 - Package of red shockproof protective rubber with caps for the G0601 boom;

G0460 - Package of 6 24V warning lights with brackets for the G0601 booms plus intermittence board;

G0461 - Red reflecting adhesive strips for boom (24 piece set);

G0462 - Fixed boom rest;

G0463 - Mobile boom rest;

G0465 - Varnished aluminium hanging boom-rack;

G0467 - Joint for the G0601;

G0468 - Support for applying DOC series photocells to cabinet;

G0469 - Support for applying the flashing light to the cabinet;

LB38 - Battery card for connecting 3 12V-7Ah batteries.

Important! Check that the safety equipment and accessories are CAME originals; this is a guarantee that also makes the system easy to set up and upkeep.

4.2 Dati tecnici

MOTORIDUTTORE

Power supply: 230 V AC 50/60Hz
 Power to motor: 24V DC 50/60Hz
 Max power draw: 1.3A max. (230V) / 15A max. (24V)
 Rated power: 300W
 Max torque: 600 Nm
 Gear ratio: 1/202
 Opening interval; 4 to 8 seconds
 Duty cycle: intensive use.
 Protection rating: IP54
 Weight: 72kg
 Insulation class: I

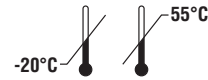

4.3 Technical description

OPERATOR UNIT

- A - 2,5 mm-thick sheet metal cabinet with galvanised, varnished finish (G6000 RAL=2004), or 2 mm-thick satin polished stainless steel (G6001), ready to fit all accessories.
Inspection door with custom key.
- B - Anchoring base with galvanised finish with four brackets and nuts to secure the cabinet to the floor.
- C - Boom attachment flange with galvanised finish; provides quick, safe locking of the boom and can take different types of booms.
- D - Gearmotor clutch release with custom key.
- E - 24V DC motor.
Irreversible gearmotor with die-cast aluminium case; worm screw transmission with permanent liquid grease lubrication.
All rotating parts are fitted onto permanently lubricated bearings or self-lubricating ball-joints.
- F - Counter-spring and motion balance.
- G - Internal, mechanical, safety stops.
- H - Limit switch assembly.
- I - Adjustable transmission arm (for regulating position of barrier rod).
- L - ZL37 control panel.

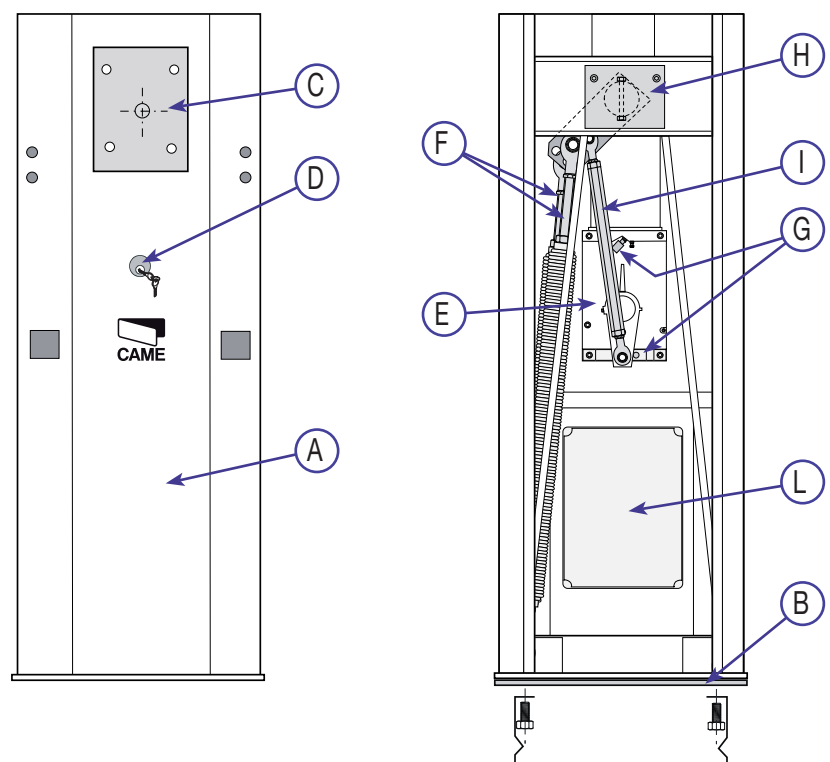

4.4 Size measurements

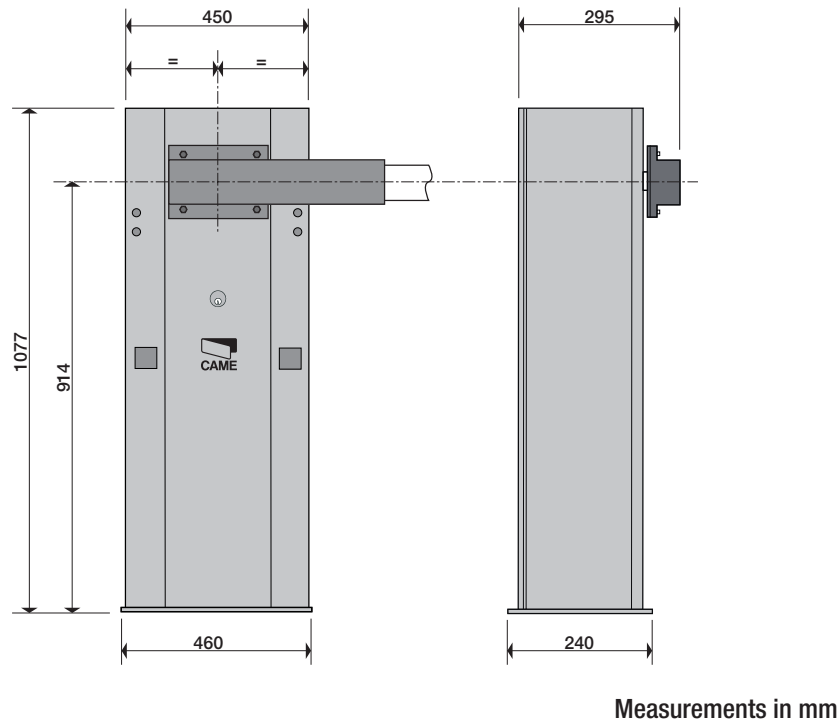

5 Installation

⚠ Installation must be carried out by expert qualified personnel and in full observance of regulations in force.

5.1 Preliminary checks

⚠ Before proceeding with the installation, it is necessary to:

- Make sure the area selected for the mounting of the base and for the unit itself presents no hazards;
- Provide for suitable omnipolar disconnection device with more than 3 mm between contacts to section power supply;
- \oplus Connections inside the case made for protection circuit continuity are allowed as long as they include additional insulation with respect to other internal drive parts;
- Install suitable tubes and ducts for electric cable passage to guarantee protection against mechanical damage;

5.2 Tools and materials

Make sure all tools and materials necessary are within reach to install the edge in maximum safety, according to regulations in force. The following figure illustrates the minimum equipment for the installer.

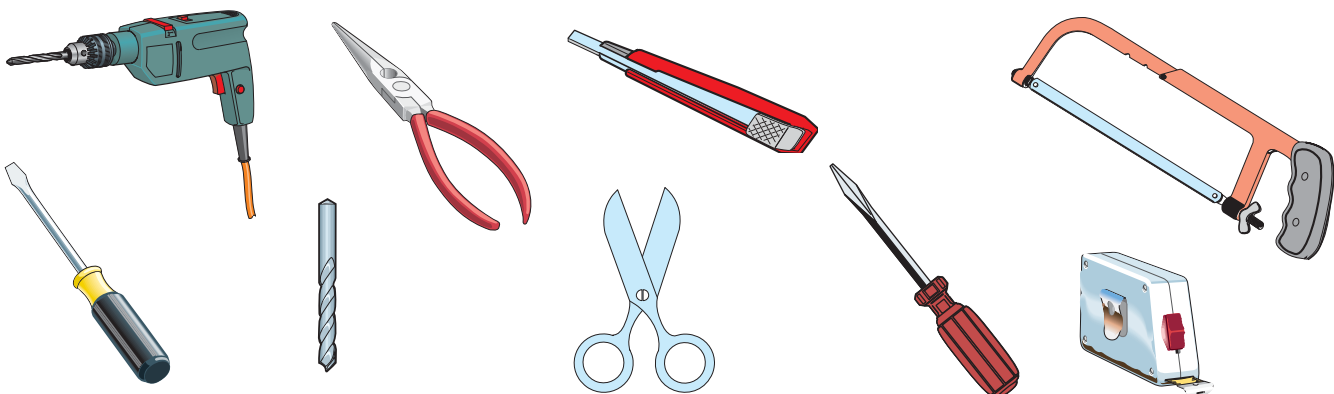

5.3 Cable list and minimum thickness

Connections	Type of cable	Length of cable 1 < 10 m	Length of cable 10 < 20 m	Length of cable 20 < 30 m
230V 2F power supply	FROR CEI 20-22 CEI EN 50267-2-1	3G x 1,5 mm ²	3G x 2,5 mm ²	3G x 4 mm ²
Photoelectric cells TX		2 x 0,5 mm ²	2 x 0,5 mm ²	2 x 0,5 mm ²
Photoelectric cells RX		4 x 0,5 mm ²	4 x 0,5 mm ²	4 x 0,5 mm ²
24V power supply accessory		2 x 0,5 mm ²	2 x 0,5 mm ²	2 x 1 mm ²
Safety and control devices		2 x 0,5 mm ²	2 x 0,5 mm ²	2 x 0,5 mm ²
Antenna connection	RG58	max. 10m		
Metallic mass detector	(see documents provided with product)			

N.B.: An evaluation of the size of the cables with lengths other than the data in the table must be made based on the effective absorption of the connected devices, according to the instructions indicated by the CEI EN 60204-1 standards. For connections that require several loads on the same line (sequential), the size given on the table must be re-evaluated based on actual absorption and distances.

5.4 Standar installation

- | | |
|-----------------------------------|--------------------------------|
| 1 - GARD group | 9 - Keypad selector switch |
| 2 - Control panel | 10 - Emergency batteries |
| 3 - Aluminium boom | 11 - Photocell post |
| 4 - Red reflecting strips | 12 - Safety photocells |
| 5 - Antenna | 13 - Magnetic card reader post |
| 6 - Protective rubber | 14 - Fixed rest |
| 7 - Warning lamps | 15 - Magnetic sensor |
| 8 - Motion warning flashing light | |

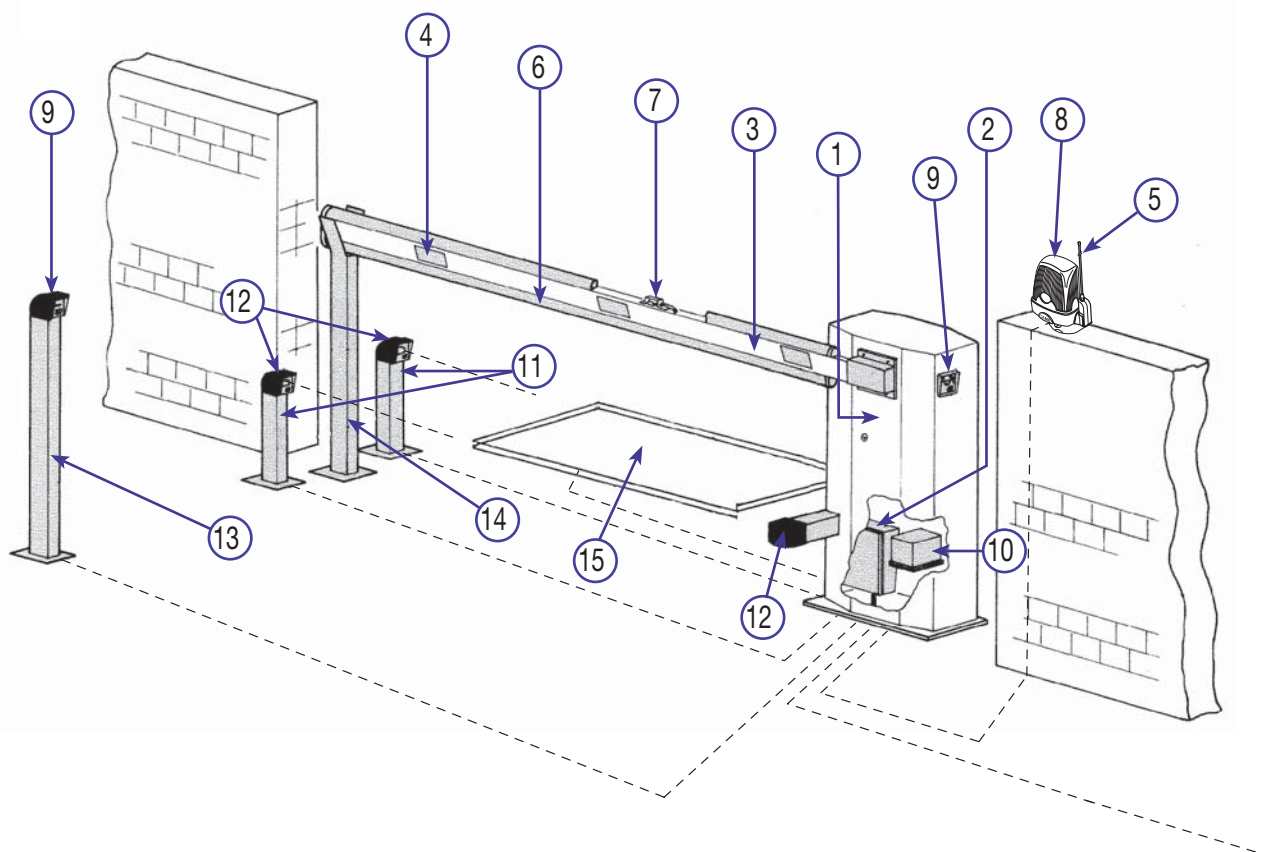

5.5 Fitting for unit base

 The following applications are only examples, as the space required for unit installation and the accessories vary depending on dimensions and therefore it is up to the installer to select the best solution.

- Prepare a hole to house the fixing base and prepare sheath tubes from the branch pit for the connections.
N.B. the number of tubes depends on the type of system and the accessories you will hook up.

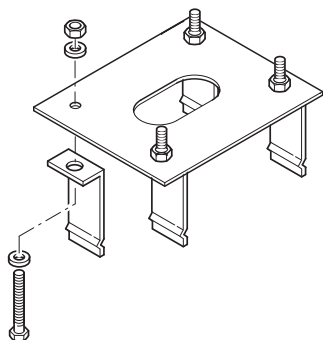
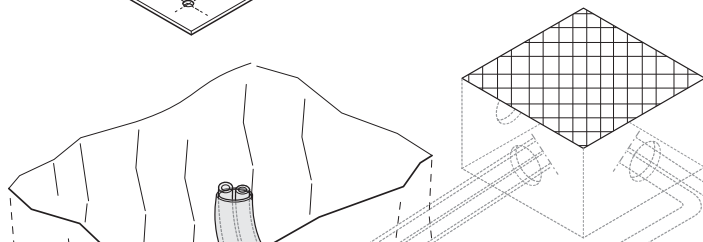
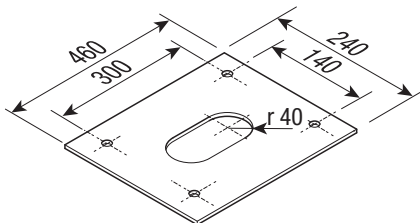

- Assemble the four anchoring clamps at the base.

- Fill the hole with concrete and immerge the clamps and the fixing base, paying particular attention to the sheath tube which must go through the hole at the base. The base must be perfectly level, clean and with the screw threads fully on the surface.

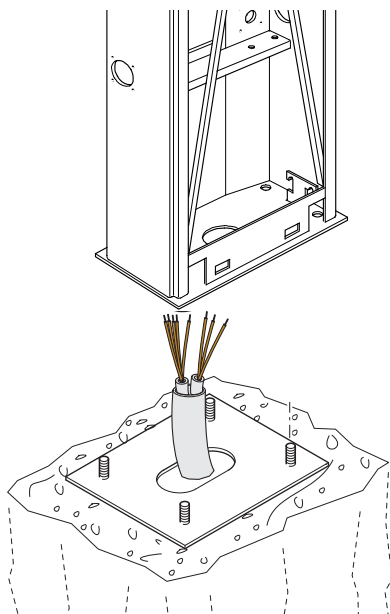
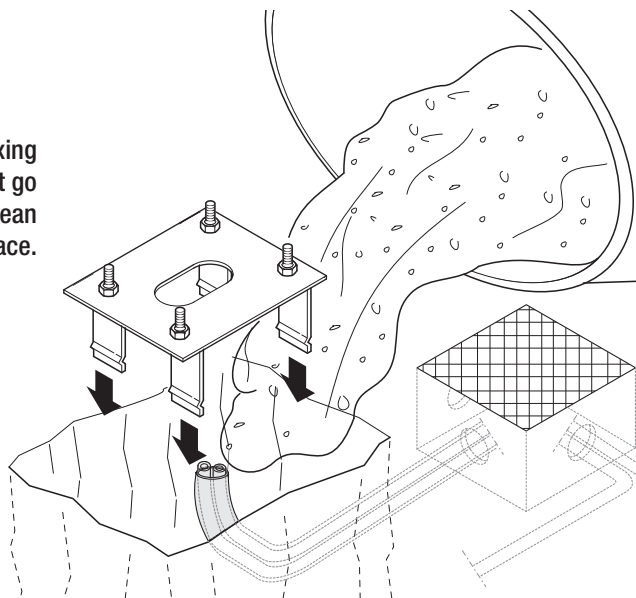

- Remove the nuts and washers from the threaded screws, position the cabinet on the base in correspondence with the 4 threaded screws and secure with the nuts and washers.

Note: We recommend installing the cabinet with the inspection hatch facing the internal area.

5.6 Installation

- Start by laying out the unit: it is best to install the cabinet with the inspection door facing into the property (see p. 8). Mount the boom calculating the right length and secure via the A boom-supporting attachment using the four supplied bolts. Set both vertical and horizontal grades of the bar by using the mechanical stop B and transmission lever C.

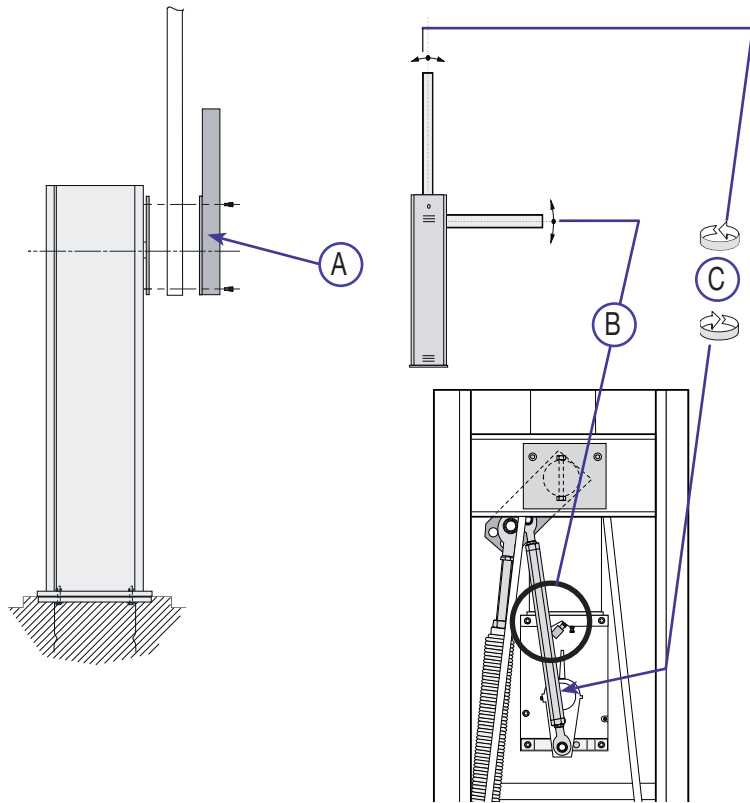

5.7 Balancing the boom

Barrier G6000 is supplied with spring installed at position **B**. If the final configuration of your barrier requires a change in the position of the spring (see illustrations), unlock the gear motor (p. 8) and change the position of the spring (keep any springs you have changed). If precise balancing of the barrier rod is required, see the next page.

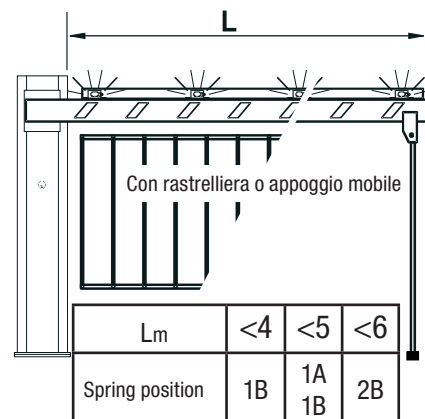
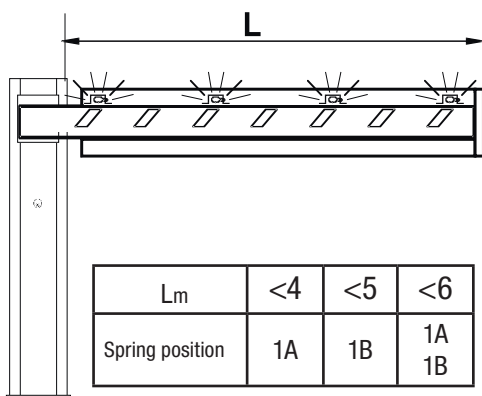
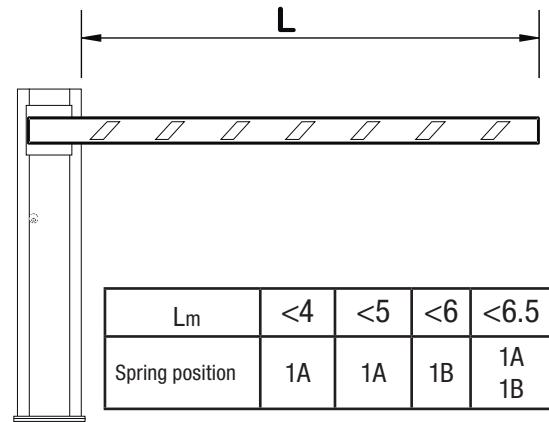
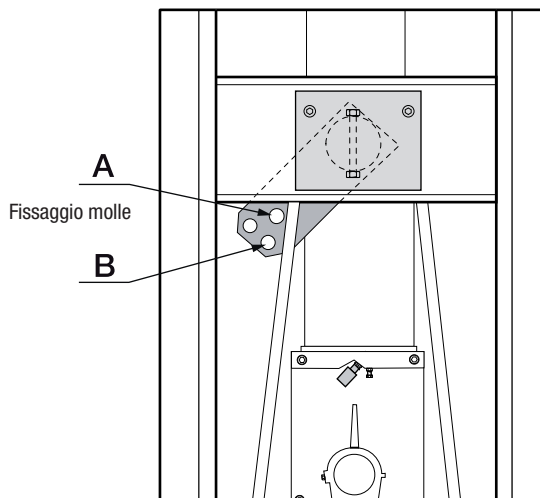

To properly balance the barrier boom, do the following:

- 1) - Unlock the gear motor;
- 2) - Loosen locknut B on tension rod A;
- 3) - Manually adjust the spring to increase/decrease its tension until the barrier rod stabilises at a 45° angle;
- 4) - Now, tighten the locknut and lock the gear motor.

⚠ WARNING!
 Unlocking the barrier may be dangerous for users if the boom is wrongly secured during installation, or if the boom is cracked or damaged accidentally, and so on, and so the springs no longer perform to provide counter balance! This can cause sudden rotation of the boom attachment or boom itself.

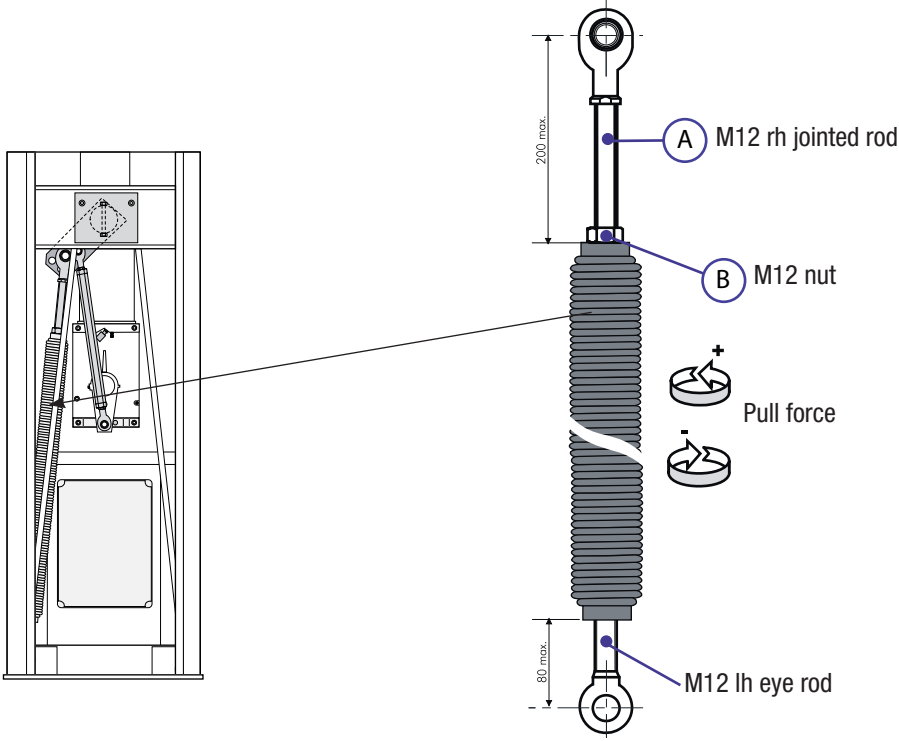
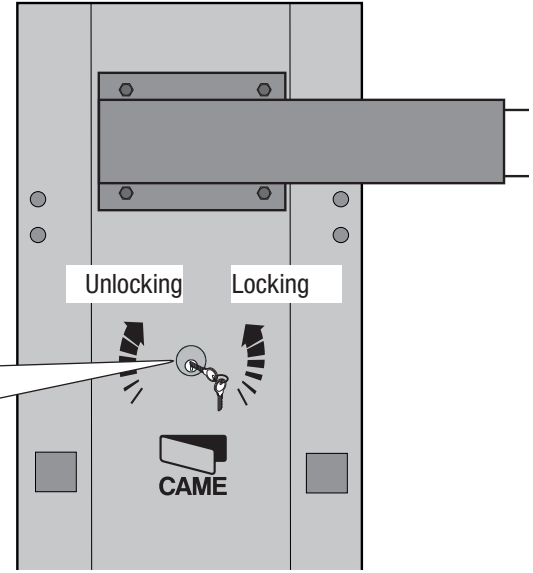

5.8 Right handed/left handed barrier

To change sense of rotation, request documentation from your local dealer or contact CAME in your country (see last page, otherwise go to www.came.com).

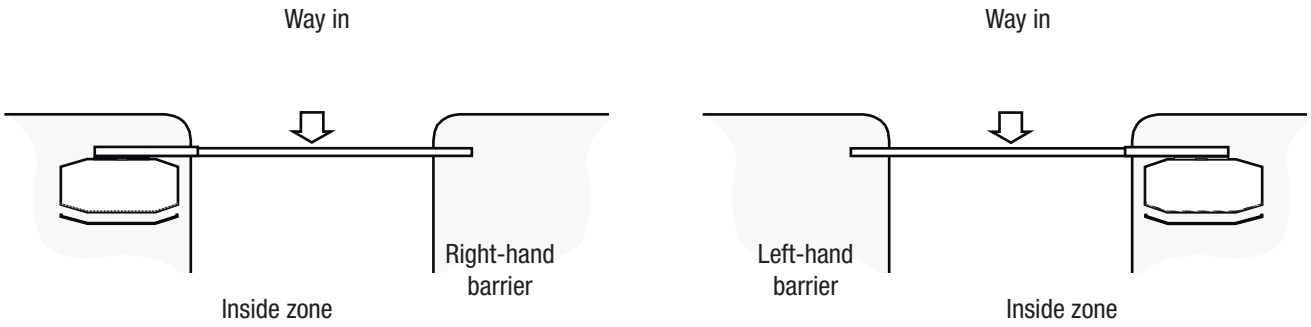

6 Description control panel

This product is engineered and manufactured by CAME cancelli automatici s.p.a. and complies with current safety regulations.

The control panel works on 230V a.c. of power, 50/60Hz frequency.

Both command and control devices and accessories are 24V powered. *Warning! Accessories must not exceed 20 W overall.*

The control unit is fitted with an amperometric device which constantly regulates the motor's drive coefficient. When the bar runs into an obstacle, the amperometric sensor immediately detects an overcharge in the drive and redirects the gate's direction of movement, and:

- during opening: the bar stops;
- during closing: the bar reverses its direction until it opens completely; automatic closure is thus activated.

Caution! after three consecutive direction reversals, the bar will remain up and automatic closure will be discontinued. To close the gate, use the radio remote control or the push-button.

All connections are protected by quick fuses, see table.

The card provides and controls the following functions:

- automatic closing after an open-command;
- immediate closure;
- pre-flashing by the motion indicator;
- obstacle detection when gate is still in any position;
- re-opening while closing
- slave function;
- function that increases the braking action of the barrier.

The following command modes are possible:

- open/close;
- open/close and maintained action;
- open;
- complete stop.

Apposite trimmers regulate:

- the automatic closing run time;
- the amperometric device's detection sensitivity;

Optional accessories:

- bar open light marks the position of opening of the bar; it turns off after the closing operation;
- The LB38 board, provides emergency battery power via three 12V – 7Ah cell batteries in case of a power failure. When the power supply is restored, the batteries are recharged automatically (see instruction sheet);

WARNING! Before acting on the machinery, cut off the main power supply and disconnect any emergency batteries.

TECHNICAL FEATURES

Power supply	230V - 50/60Hz
max. rated power	300W
Power draw	15A max
Insulation rating	□
Material	ABS

FUSE TABLE

to protect:	fuse type:
Electronic board (line)	3.15A-F
Accessories	2A-F
Command devices (panel)	630mA-F

6.1 Main components

- 1) Terminal boards for external connections
- 2) Line fuse
- 3) Accessories fuse
- 4) "Select Function" dip-switch
- 5) Radiofrequency terminal board socket (see table)
- 6) TCA trimmer: automatic closing time adjustment
- 7) SENS trimmer: amperometric sensitivity adjustment
- 8) Button for memorising codes
- 9) Radio code / automatic closing signal LED
- 10) Connectors for power supply to motor
- 11) Connectors for connecting battery charger (LB38)
- 12) Jumper for control type selection for button in 2-7

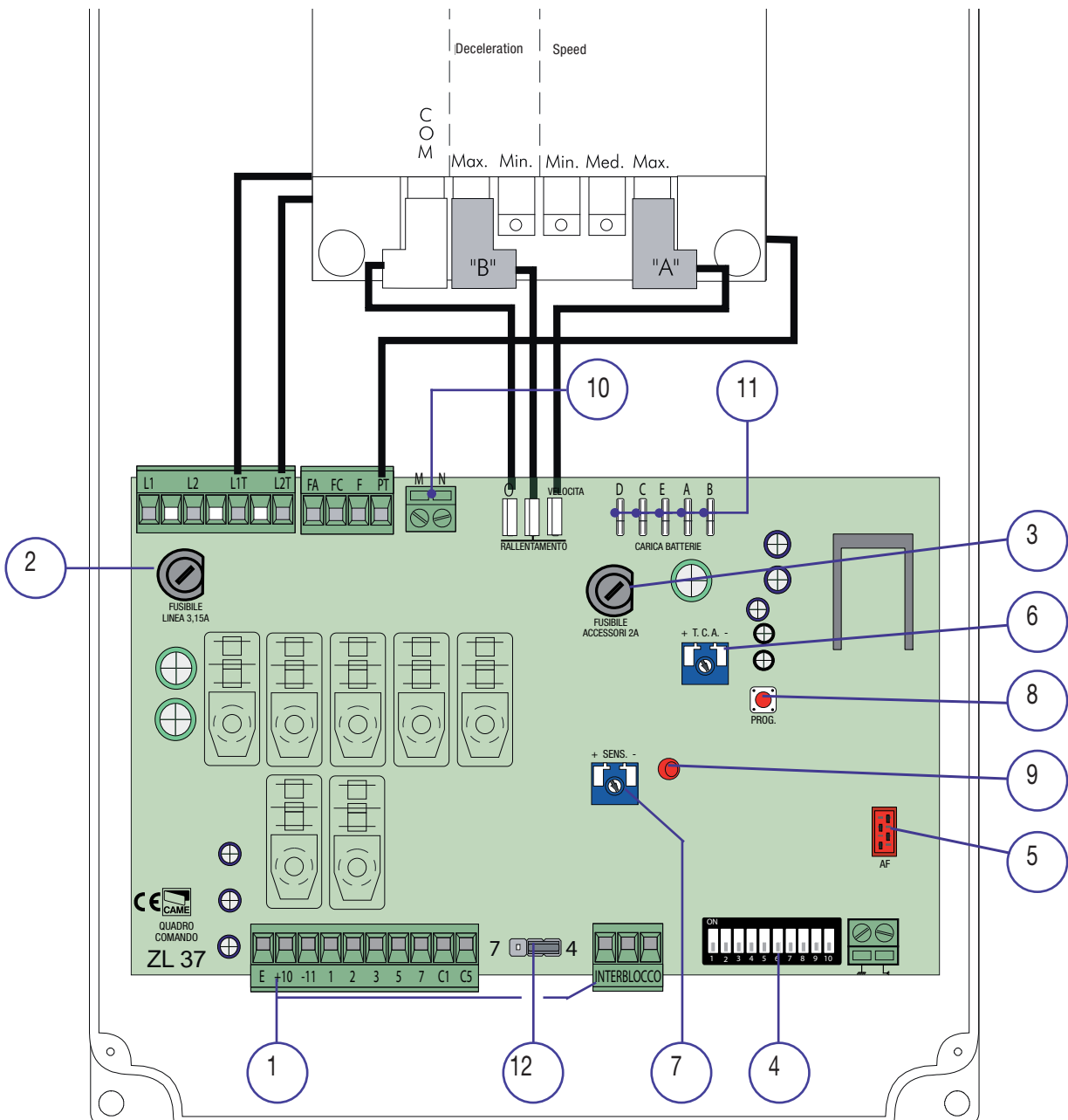

6.2 Electrical connections

Gearmotor, endstop

The swing-joint in the picture (which is factory made) is for a left-hand barrier (see par. 5.8).

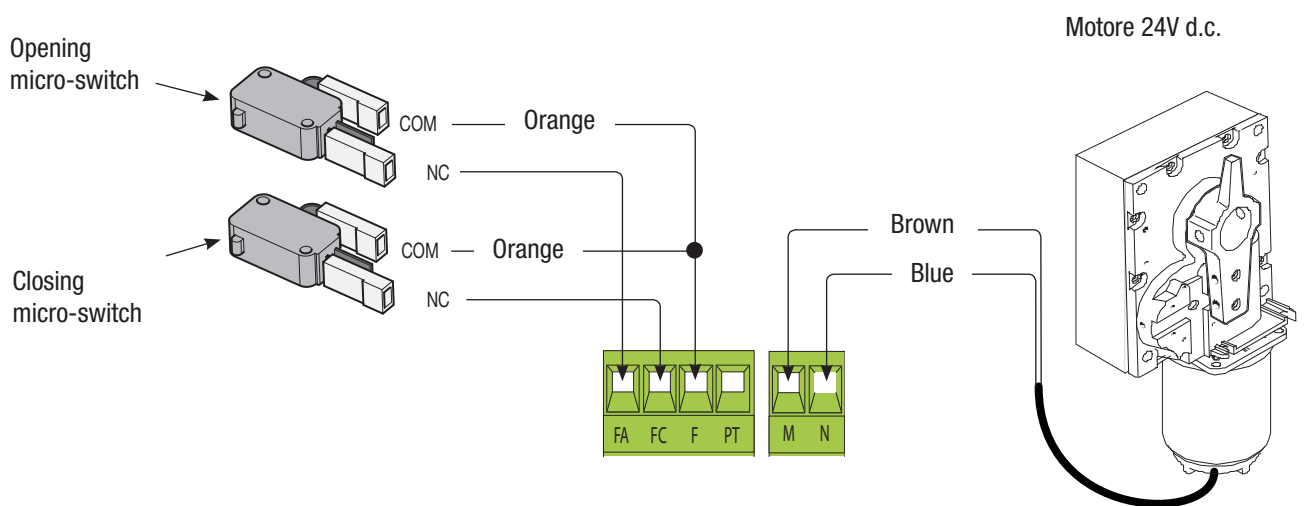

Power source

Terminals for powering up accessories:
 - a 24V a.c. con alimentazione a 230V a.c.
 - a 24V d.c. con alimentazione a 24V d.c.
 Potenza complessiva consentita: 40W

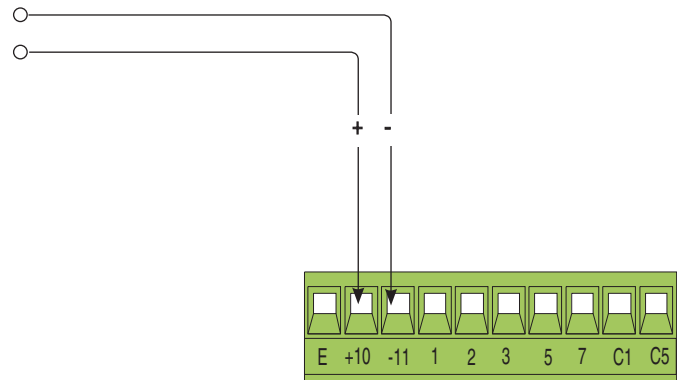

Powered by 230V AC, 50/60 Hz

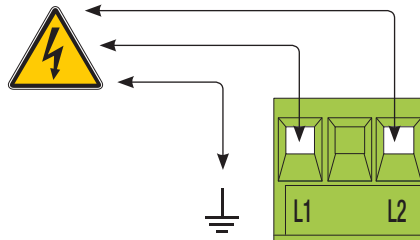

Signalling devices

24V DC – 25W output socie

When moving (e.g. the - flashing light). DIP 3 on OFF

- Flashing during the opening and closing cycles.

Operates during the opening and closing cycles and when the barrier is closed. DIP 3 on ON

Open barrier pilot light (contact rating: 24V – 3W max.)

- Signals that the boom is raised, and turns off when the boom is down.

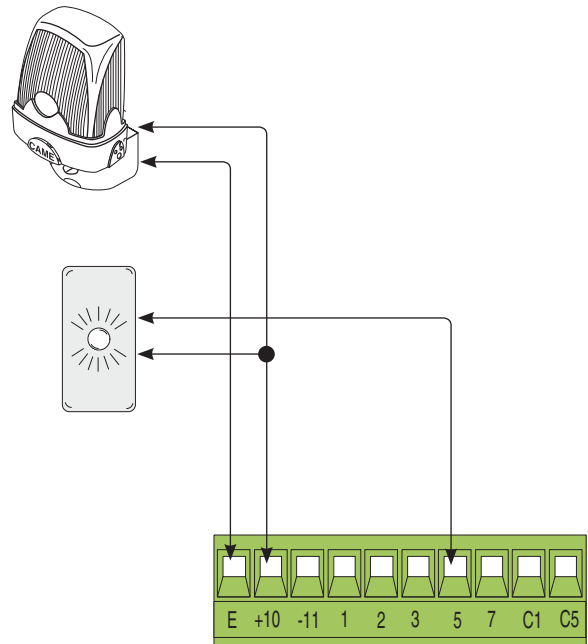

Command devices

Pulsante Stop button (N.C. socket) - Bar stop button.

Excludes automatic closing. For motion to resume, press the command button or the remote control button.

If unused, set Dipswitch 9 to ON.

Opening button (N.O. contact) - Bar opening command.

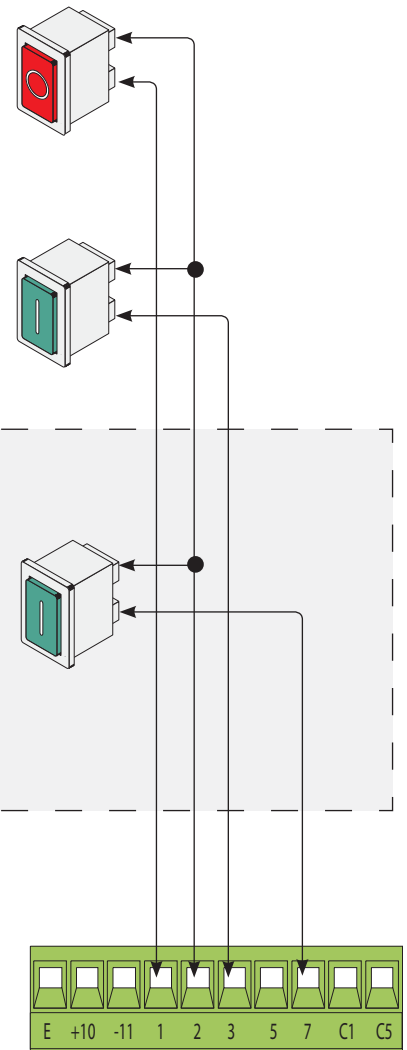

Radio and/or button connection (N.O. contact).

- Boom opening and closing command. Pressing the button inverts movement of the boom.

Check position of Jumper (n.12, page 10) as shown in the figure.

Button operation: close only – Boom closing command. This command is obligatory when in “maintained action”.

Position the jumper as shown in the figure.

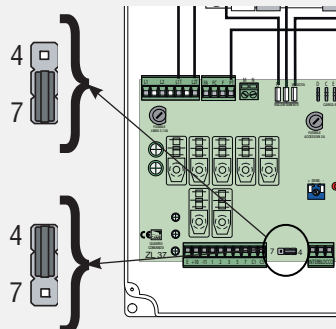

Safety devices

Contact (N.C.) for "immediate closing"

Automatic bar closing after an obstacle comes within the range of the safety devices.

If unused, set Dipswitch 8 to ON.

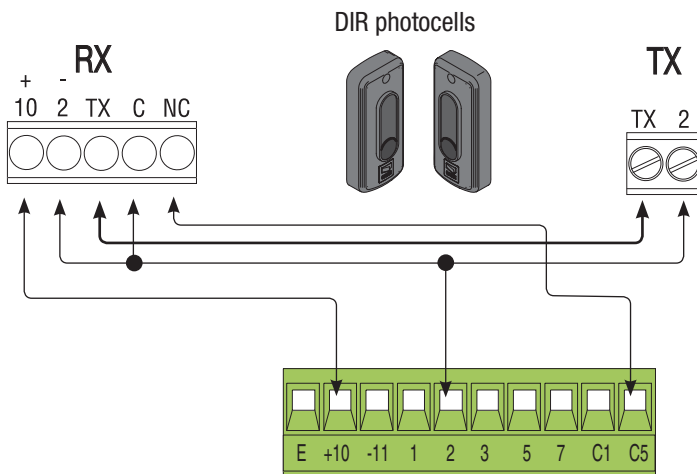

Contact (N.C.) for "re-opening while closing"

- input for safety devices like photocell, compliant with EN 12978. When the boom is in closing cycle, the contact opening causes the movement to invert until boom is fully opened.

If not used, short-circuit contact 2-C1.

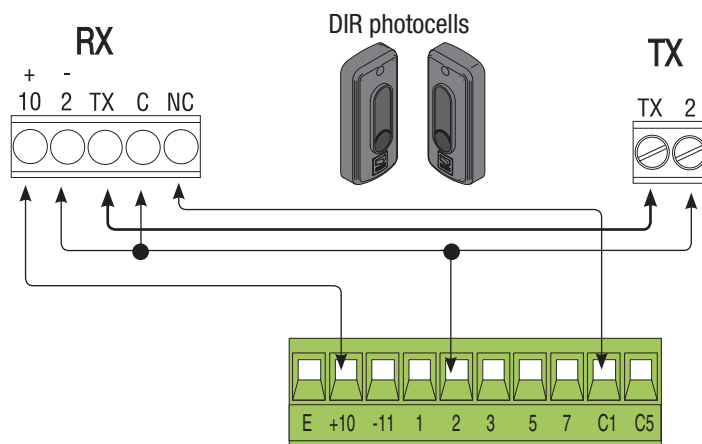
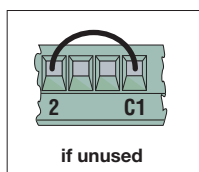

Contact (N.C.) for "immediate closing"

If not used, position Dip switch 8 to ON.

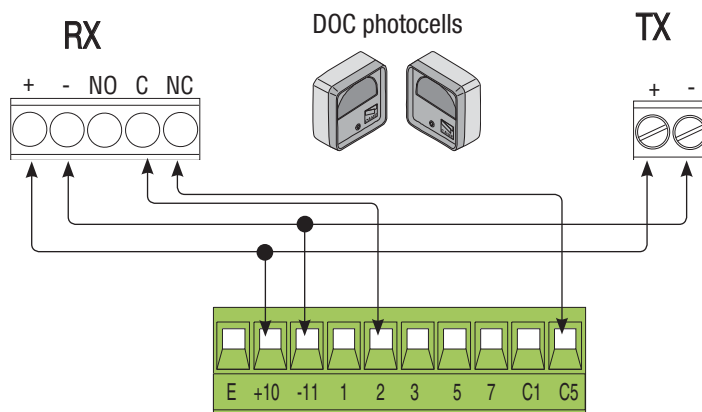

Contact (N.C.) for "re opening when closing"

If not used, short-circuit contact 2-C1.

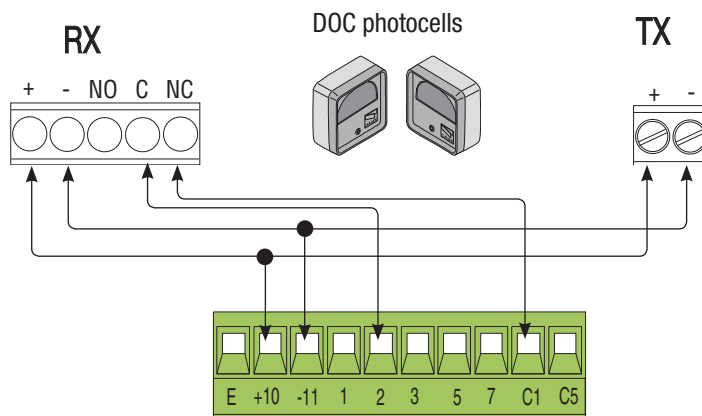
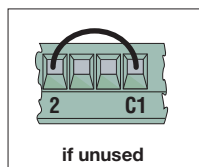

6.3 Selecting functions

- 1 ON** Automatic closing **enabled**;
- 2 ON** Radio command operation “open only” **enabled** (with radiofrequency card slot);
- 2 OFF** Radio command operation “open-close-inversion” **enabled** (with radiofrequency card slot);
- 3 ON** 24V voltage in output on terminals 10-E during movement cycles and when in the barrier closed position, **enabled**;
- 3 OFF** 24V voltage in output on terminals 10-E during barrier movement cycles, **enabled**;
- 4 ON** “man present” function **enabled**;
- 5 ON** Pre-flashing for 5 seconds while opening and closing, **enabled**;
- 6 ON** Obstacle detection (when motor is at end of stroke), **enabled**;
- 7 ON** “Slave” operation (motor is controlled externally) **enabled**;
- 8 OFF** Immediate closing function **enabled**; activate safety device (2-C5);
- 9 OFF** “Stop” button **enabled**; activate safety device (1-2);
- 10 ON** Function that increases the braking action on the barrier **enabled**.

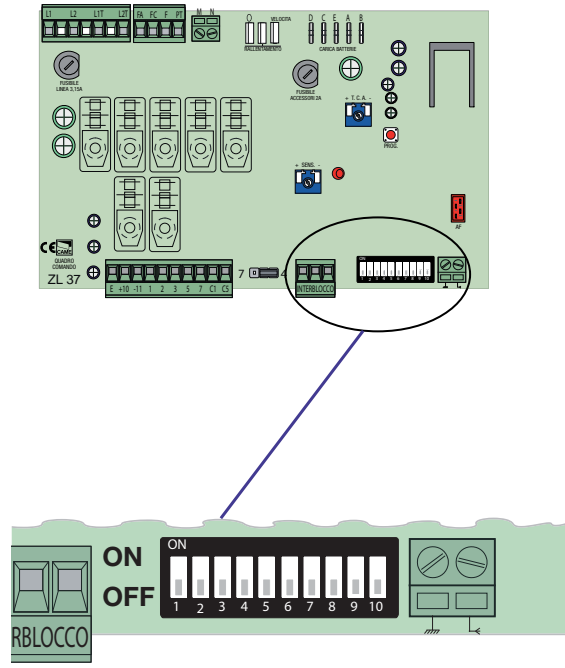

6.4 Settings

Trimmer T.C.A. = Automatic closing time min. 1", max. 120".
Trimmer SENS. = Sensitivity of the amperometric device (min./ max.)

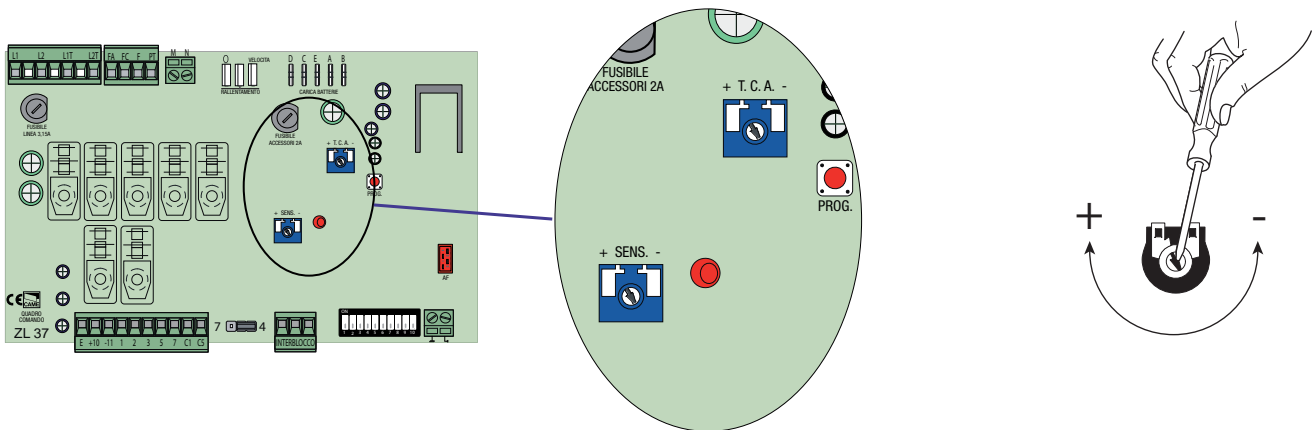

7 Enabling the radio command

Antenna

Connect RG58 antenna cable to the proper terminals.

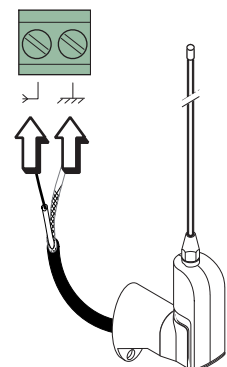

Radio frequency card

Only for the AF43S / AF43SM radio frequency cards:
 - position the jumper as illustrated depending on the series of transmitters used.

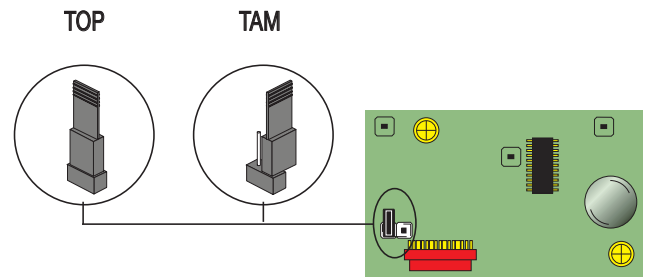

Lock the radiofrequency card into the electronic card **AFTER CUTTING OFF THE POWER SUPPLY** (or after disconnecting the batteries).
 N.B.: the electronic card only recognises the radiofrequency card when the power is on.

Frequency-MHz	radiofrequency card	Series of transmitters
FM 26.995	AF130	TFM
FM 30.900	AF150	TFM
AM 26.995	AF26	TOP
AM 30.900	AF30	TOP
AM 40.685	AF40	TOUCH
AM 433.92	AF43S / AF43SM	TAM / TOP
	AF43SR	ATOMO
	AF43S / AF43TW	TWIN
AM 868.35	AF868	TOP

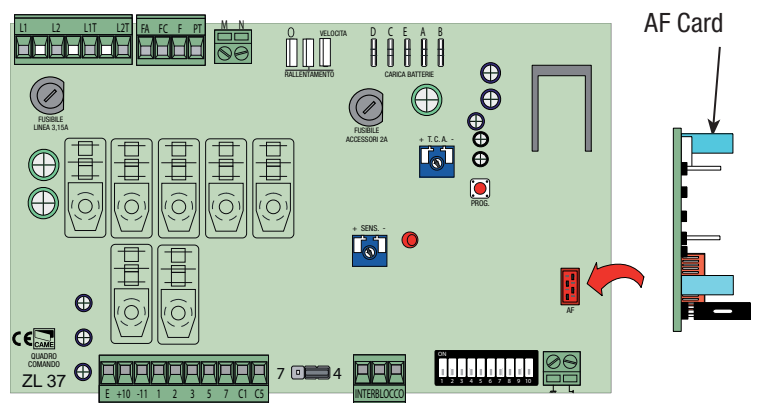

Transmitters

See attached instructions

TOUCH
 TCH 4024 • TCH 4048

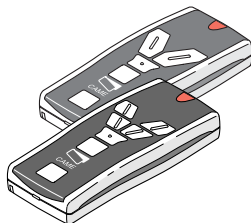

TOP
 TOP-432A • TOP-434A
 TOP-302A • TOP-304A

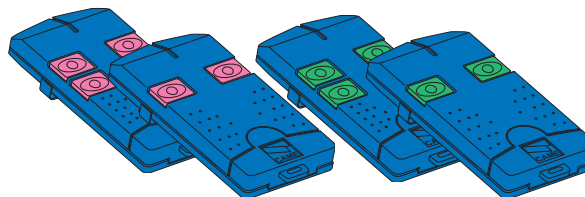

TOP
 TOP-432NA • TOP-434NA
 TOP-862NA • TOP-864NA
 TOP-432S

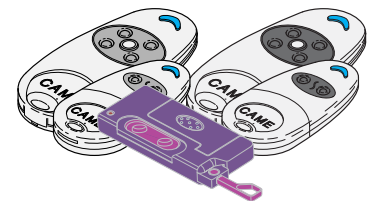

TWIN
 TWIN 2 • TWIN 4

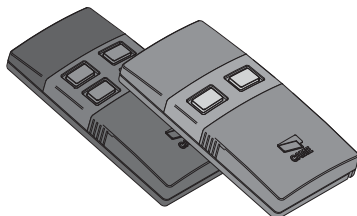

TAM
 T432 • T434 • T438
 TAM-432SA

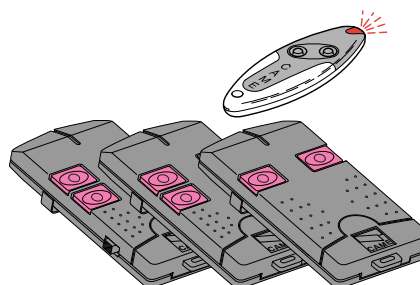

TFM
 T132 • T134 • T138
 T152 • T154 • T158

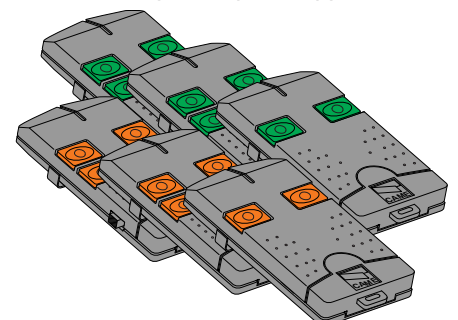

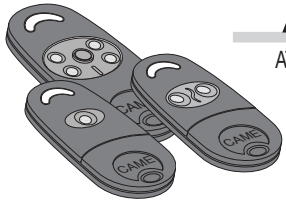

ATOMO
AT01 • AT02
AT04

See instructions attached to
AF43SR radiofrequency card

Memorising

- Keep pressed the **PROG** button on the electronic board. The LED light will flash

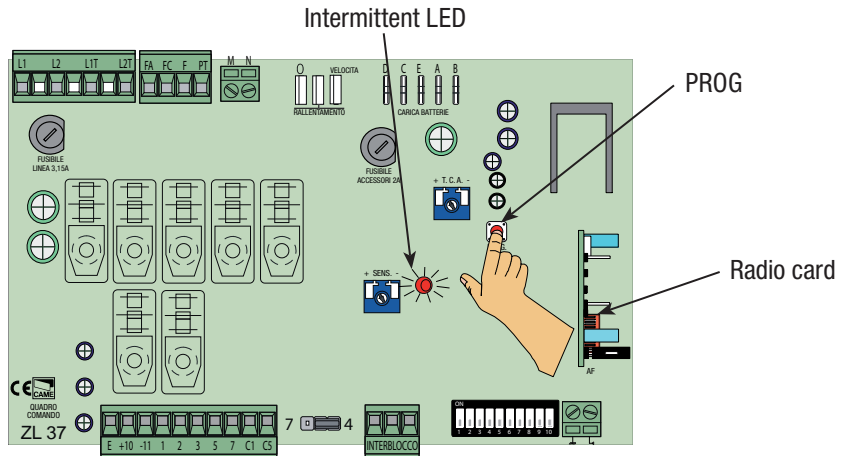

- Press the button of the transmitter to be memorie. The LED light will stay lit to signal that memorisation was successful.

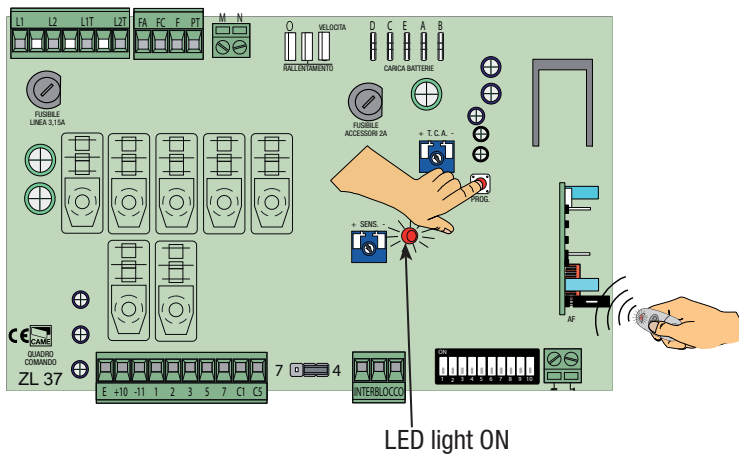

N.B.: to change code at a later date, just repeat the described sequence.

8 Adjusting closing-opening and deceleration speed

To adjust the motion speed move the "A" faston connector. For slowdowns move the "B" faston connector.

Eg: max. speed during opening and closing - max. deceleration (see drawing below).

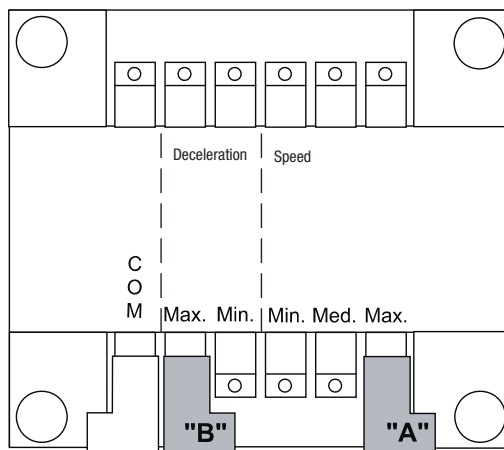

9 Connecting two combined barriers that have a single command

- Decide which will be the **Master** barrier (or pilot barrier, that is, which motor will command both barriers) and which will be the **Slave** (the motor piloted by the Master).

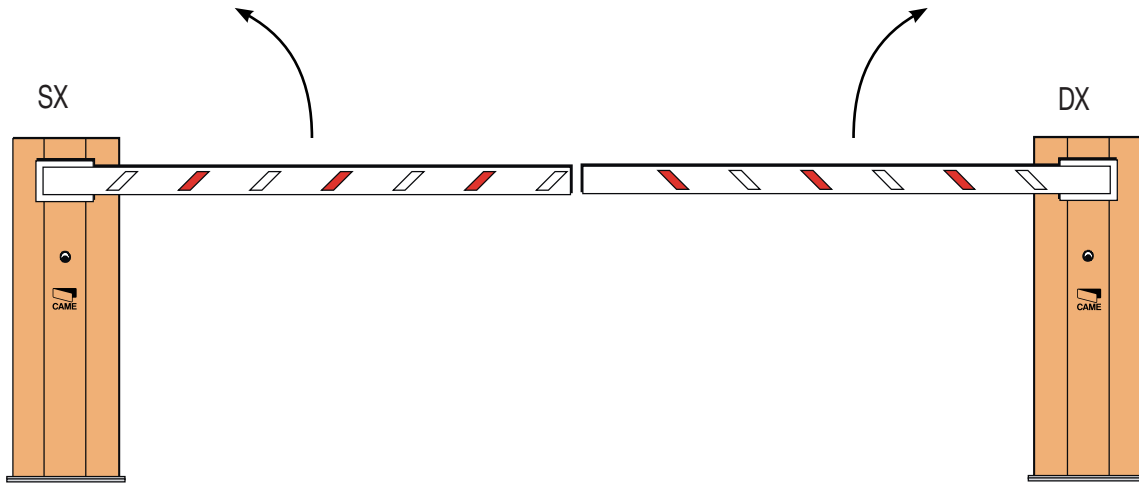

- 1) On one of the two control panels, set Dip 7 to ON in order to select the motor controlled externally (SLAVE).

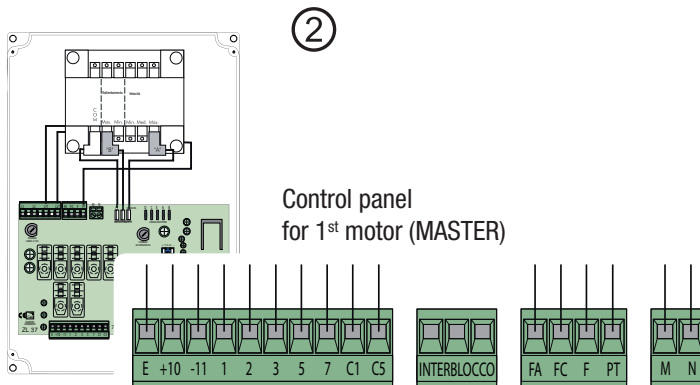
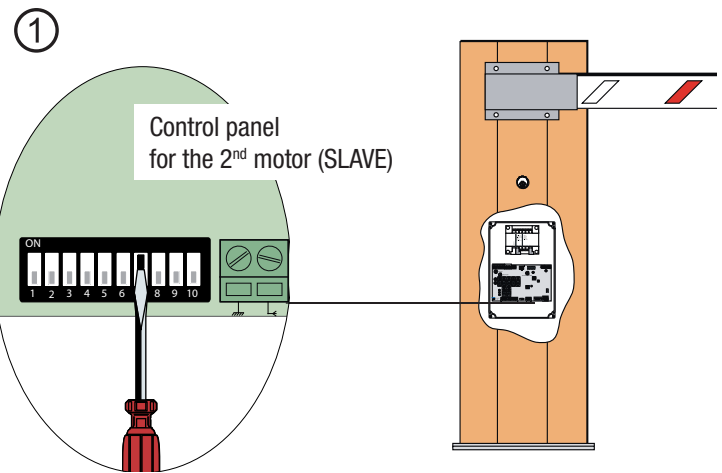

- 2) Wire only the normal the electrical connections on the (MASTER) terminal board.

- 3) Connect the two control panels using the INTERLOCK terminals as shown in the figure.

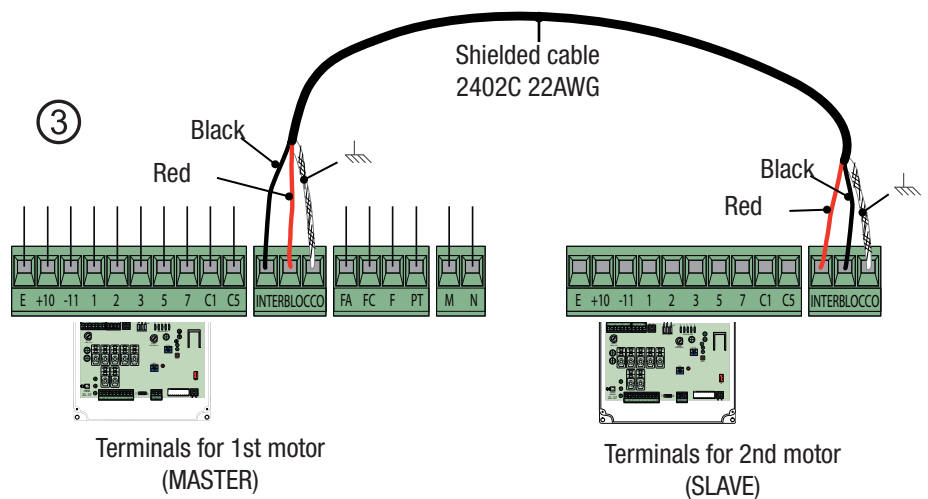

9 Safety instructions

Important safety instructions

This product must only be employed for its originally intended use. Any other use is wrong and potentially dangerous. The manufacturer cannot be held liable for any damages resulting from wrongful, erroneous or negligent uses.

Avoid using near mechanical moving parts. Stay out of the opening/closing arc when operator is in motion.

Do not exercise force against the motion of the operator as this could result in potentially dangerous situations.

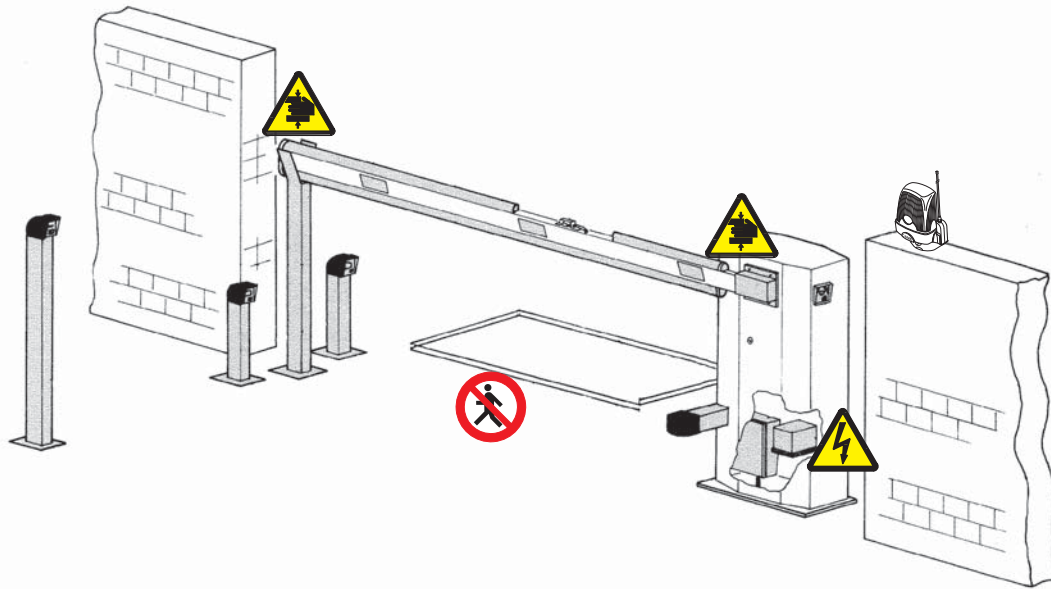

Do not allow children to play or loiter within the opening/closing arc of the operator. Keep remote controls and any other command device out the reach of children, to prevent operator from being activated by accident.

In the event of anomalous behaviour, stop using the operator immediately.



Danger of crushing hands



Danger! High voltage



No transit during operation

10 Maintenance

10.1 Periodic maintenance

 Periodic maintenance to be carried out by the end-user is as follows: wipe clean the glass surface of the photocells; check that the safety devices work properly; remove any obstruction.

We suggest checking the state of lubrication and tightness of the anchoring screws on the operator.

-To check the efficiency of the safety devices, move an object in front of the photocells when gate is closing. If the operator inverts the motion or stops, the photocells are working properly.

This is the only maintenance procedure to be carried out with the power source connected.

-Before performing any maintenance procedures, cut off the main power, to prevent possible accidents due to bar movement.

-To clean the photocells use a water dampened cloth. Do not use solvents or other chemical products which may ruin the devices.

-Make sure there are no plants within the photocell's beam, and that the bar motion is free of any obstacles.

10.2 Extra-ordinary maintenance

 The following table serves to note down any extraordinary maintenance, repairs or improvements performed by specialised firms.

N.B.: Any extraordinary maintenance must be performed by specialised technicians.

Extra-ordinary maintenance log

Installer's stamp	Operator name
	Date of job
	Technician's signature
	Requester's signature
Job performed _____ _____ _____	

Installer's stamp	Operator name
	Date of job
	Technician's signature
	Requester's signature
Job performed _____ _____ _____	

Installer's stamp	Operator name
	Date of job
	Technician's signature
	Requester's signature
Job performed _____ _____ _____	

Installer's stamp	Operator name
	Date of job
	Technician's signature
	Requester's signature
Job performed _____ _____ _____	

Installer's stamp	Operator name
	Date of job
	Technician's signature
	Requester's signature
Job performed _____ _____ _____	

Installer's stamp	Operator name
	Date of job
	Technician's signature
	Requester's signature
Job performed _____ _____ _____	

10.3 Problem solving

MALFUNCTIONS	REFERENCES	CHECKS
The unit neither opens nor shuts	1-2-3-4-6-8-18	1 – Close the inspection hatch with the key and check the release lock
The unit opens but does not close	4-7-10	2 - Disable “steady movement” with dipswitch
The unit shuts but does not open	4-7-9	3 – Check power supply and fuses
No automatic closure	11-12-13	4 - N.C. safety contacts open (1-2 / 2-C1 / 2-C5)
The unit does not work if the remote control is used	2-14-16	6 - Disable master-slave function
The unit inverts direction	7-18	7 – Check spring tension and balancing
The unit works only with remote control	22	8 – Disable obstacle detection with dipswitch
The photoelectric cell does not react	12-23-24	9 – Check if end stop opens
The signalling LED indicator flashes rapidly	4	10 – Check if end stop closes
The signalling LED indicator remains on	13	11 - Activate “automatic closure” dip switch
The unit does not end its run	7	12 – Check the correct direction of movement
The bar is not properly balanced	7-15	13 - (2-3 / 2-4 / 2-7) command button
The unit does not slow down	7-15	14 –Check jumper on AF43S, turn on/off power
The unit does not work with the back-up batteries	8-25-26	15 – Check the bar length ratio with mountable accessories
The unit is slow to respond	7	16 – Re-save radio code
		18 – Adjust sensitivity
		22 - Enter or duplicate the same code in all the remote controls
		23 – Activate the photoelectric cell with the dipswitch
		24 – Connect the photoelectric cells in a series, not in parallel
		25 – Dead batteries
		26 –Respect the photoelectric cells’ polarity

11 Demolition and disposal

 In its premises, CAME CANCELLI AUTOMATICI S.p.A. implements an Environmental Management System certified in compliance with the UNI EN ISO 14001 standard to ensure environmental protection.

Please continue our efforts to protect the environment—which CAME considers one of the cardinal elements in the development of its operational and market strategies—simply by observing brief recommendations as regards disposal:

 **DISPOSAL OF PACKAGING** – The packaging components (cardboard, plastic, etc.) are all classifiable as solid urban waste products and may be disposed of easily, keeping in mind recycling possibilities.

Prior to disposal, it is always advisable to check specific regulations in force in the place of installation.

PLEASE DISPOSE OF PROPERLY!

 **PRODUCT DISPOSAL** – Our products are made up of various types of materials. Most of them (aluminium, plastics, iron, electrical wires, etc.) may be disposed of in normal garbage collection bins and can be recycled by disposing of in specific recyclable material collection bins and disposal in authorized centres. Other components (electrical boards, remote control batteries, etc.), however, may contain polluting substances. They should therefore be removed and given to qualified service companies for proper disposal.

Prior to disposal, it is always advisable to check specific regulations in force in the place of disposal.

PLEASE DISPOSE OF PROPERLY!



English - Manual code: **119G26** ver. **7.2** 11/2011 © CAME cancelli automatici s.p.a.
The data and information reported in this installation manual are susceptible to change at any time and without obligation on CAME cancelli automatici s.p.a. to notify users.

IT • Per ogni ulteriore informazione su azienda, prodotti e assistenza nella vostra lingua:
EN • For any further information on company, products and assistance in your language:
FR • Pour toute autre information sur la société, les produits et l'assistance dans votre langue :

DE • Weitere Infos über Unternehmen, Produkte und Kundendienst bei:

ES • Por cualquier información sobre la empresa, los productos y asistencia en su idioma:

NL • Voor meer informatie over het bedrijf, de producten en hulp in uw eigen taal:

PT • Para toda e qualquer informação acerca da empresa, de produtos e assistência técnica, em sua língua:

PL • Wszystkie inne informacje dotyczące firmy, produktów oraz usług i pomocy technicznej w Waszym języku znajdują się na stronie:

RU • Для получения дополнительной информации о компании, продукции и сервисной поддержке на вашем языке:

HU • A vállalatra, termékeire és a műszaki szervizre vonatkozó minden további információért az Ön nyelvén:

HR • Za sve dodatne informacije o poduzeću, proizvodima i tehničkoj podršci:

UK • Для отримання будь-якої іншої інформації про компанію, продукцію та технічну підтримку:



www.came.com



CAMEGROUP

CAME Cancelli Automatici S.p.a.

Via Martiri Della Libertà, 15

31030 **Dosson Di Casier** (TV)

☎ (+39) 0422 4940

☎ (+39) 0422 4941

Assistenza Tecnica/Numero Verde 800 295830