

AUTOMATION
FOR SLIDING GATES



FA00668-EN



INSTALLATION MANUAL

BX-246

EN English



CAUTION!
important personal safety instructions:
READ CAREFULLY!



FOREWORD

• THIS PRODUCT SHOULD ONLY BE USED FOR THE PURPOSE FOR WHICH IT WAS EXPLICITLY DESIGNED. ANY OTHER USE IS CONSIDERED DANGEROUS. CAME S.P.A. IS NOT LIABLE FOR ANY DAMAGE RESULTING FROM IMPROPER, WRONGFUL OR UNREASONABLE USE • KEEP THESE WARNINGS WITH THE INSTALLATION AND USE MANUALS ISSUED WITH THE AUTOMATION SYSTEM.

BEFORE INSTALLING

(PRELIMINARY CHECK: IN CASE OF A NEGATIVE OUTCOME, DO NOT PROCEED UNTIL YOU HAVE COMPLIED WITH THE SAFETY REQUIREMENTS)

• CHECK THAT THE PART YOU INTEND TO AUTOMATE IS IN GOOD MECHANICAL CONDITION, BALANCED AND ALIGNED, AND THAT IT OPENS AND CLOSES PROPERLY. MAKE SURE THAT PROPER MECHANICAL STOPS ARE ALREADY IN PLACE • IF THE OPERATOR WILL BE INSTALLED AT A HEIGHT OF LESS THAN 2.5 M FROM THE GROUND OR OTHER ACCESS LEVEL, CHECK WHETHER YOU WILL NEED ANY PROTECTIONS AND/OR WARNINGS • ANY LEAVES FITTED WITH PEDESTRIAN ENTRANCES ONTO WHICH YOU WILL INSTALL AN OPERATOR MUST HAVE A BLOCKING MECHANISM WHEN THE LEAF IS IN MOTION • MAKE SURE THAT THE OPENING OF THE AUTOMATED LEAF IS NOT AN ENTRAPMENT HAZARD AS REGARDS ANY SURROUNDING FIXED PARTS • DO NOT MOUNT THE OPERATOR UPSIDE DOWN OR ONTO ANY ELEMENTS THAT MAY FOLD UNDER ITS WEIGHT. IF NEEDED, ADD SUITABLE REINFORCEMENTS AT THE POINTS WHERE IT IS SECURED • DO NOT INSTALL ONTO LEAVES NOT ON LEVEL GROUND • CHECK THAT ANY LAWN WATERING DEVICES WILL NOT WET THE OPERATOR FROM THE BOTTOM UP.

INSTALLATION

• CAREFULLY SECTION OFF THE ENTIRE SITE TO PREVENT UNAUTHORISED ACCESS, ESPECIALLY BY MINORS AND CHILDREN • BE CAREFUL WHEN HANDLING OPERATORS THAT WEIGH MORE THAN 20 KG. IN CASE, PROCURE THE TOOLS REQUIRED FOR SAFE GATE MOVEMENT • ALL OPENING COMMANDS (BUTTONS, KEY SELECTORS, MAGNETIC READERS ETC.) MUST BE INSTALLED AT LEAST 1.85 M FROM THE PERIMETER OF THE AREA OF TURNSTILE MOVEMENT, OR WHERE THEY CANNOT BE REACHED FROM OUTSIDE THROUGH THE TURNSTILE. IN ADDITION, DIRECT CONTROLS (BUTTON, TOUCH SENSITIVE KEYS, ETC.) MUST BE INSTALLED AT A HEIGHT OF AT LEAST 1.5 M AND MUST NOT BE ACCESSIBLE TO THE PUBLIC • ALL 'HOLD-TO-RUN' COMMANDS MUST BE PLACED WHERE THE MOVING GATE LEAVES, TRANSIT AREAS AND DRIVEWAYS ARE COMPLETELY VISIBLE • IF MISSING, APPLY A PERMANENT LABEL THAT SHOWS THE POSITION OF THE RELEASE MECHANISM • BEFORE DELIVERING TO THE USER, CHECK THAT THE SYSTEM IS EN 12453 (IMPACT TEST) STANDARD COMPLIANT. MAKE SURE THAT THE OPERATOR HAS BEEN PROPERLY ADJUSTED AND THAT THE SAFETY AND PROTECTION DEVICES AS WELL AS THE MANUAL RELEASE ARE WORKING PROPERLY • WHERE NECESSARY AND IN PLAIN SIGHT, APPLY THE WARNING SIGNS (E.G. GATE PLATE)

SPECIAL INSTRUCTIONS AND ADVICE FOR USERS

• KEEP THE GATE'S AREA OF OPERATION CLEAN AND CLEAR OF ANY OBSTACLES. CHECK THAT THERE IS NO VEGETATION IN THE AREA OF OPERATION OF THE PHOTOCELLS AND THAT THERE ARE NO OBSTACLES IN THE AREA OF OPERATION OF THE OPERATOR • DO NOT ALLOW CHILDREN TO PLAY WITH THE FIXED COMMAND DEVICES, OR IN THE GATE'S AREA OF OPERATION. KEEP ANY REMOTE CONTROL DEVICES (I.E. TRANSMITTERS) OR ANY CONTROL DEVICES AWAY FROM CHILDREN AS WELL, TO PREVENT THE OPERATOR FROM BEING ACTIVATED ACCIDENTALLY • THE OPERATOR IS NOT DESIGNED TO BE USED BY PERSONS (INCLUDING CHILDREN) WHOSE PHYSICAL, SENSORIAL OR MENTAL CAPACITIES ARE LIMITED, OR WHO ARE LACKING IN EXPERIENCE OR KNOWLEDGE, UNLESS SAID PERSONS CAN BE SUPERVISED OR GIVEN INSTRUCTIONS REGARDING USING THE OPERATOR BY A PERSON RESPONSIBLE FOR THEIR SAFETY • FREQUENTLY CHECK THE SYSTEM, TO SEE WHETHER ANY ANOMALIES OR SIGNS OF WEAR AND TEAR APPEAR ON THE MOVING PARTS, ON THE COMPONENT PARTS, ON THE SECURING POINTS, ON THE CABLES AND ANY ACCESSIBLE CONNECTIONS. KEEP ANY JOINTS (I.E. HINGES) LUBRICATED AND CLEAN, AND DO THE SAME WHERE FRICTION MAY OCCUR (I.E. SLIDE RAILS) • PERFORM FUNCTIONAL TESTS ON PHOTOCELLS AND SENSITIVE EDGES EVERY SIX MONTHS. TO CHECK THAT THE PHOTOCELLS WORK, PASS AN OBJECT IN FRONT OF THEM DURING CLOSING. IF THE OPERATOR REVERSES THE DIRECTION OF MOVEMENT OR COMES TO A HALT, THE PHOTOCELLS WORK CORRECTLY. THIS IS THE ONLY MAINTENANCE OPERATION THAT MUST BE CARRIED OUT WHILE THE OPERATOR IS LIVE. ENSURE THAT THE GLASS ON THE PHOTOCELLS IS KEPT CLEAN (USE A CLOTH SLIGHTLY MOISTENED WITH WATER; DO NOT USE SOLVENTS OR ANY OTHER CHEMICALS AS THESE COULD DAMAGE THE DEVICES) • IF THE SYSTEM REQUIRES REPAIRS OR MODIFICATIONS, RELEASE THE OPERATOR AND DO NOT USE IT UNTIL SAFETY CONDITIONS HAVE BEEN RESTORED • CUT OFF THE POWER SUPPLY

BEFORE RELEASING THE OPERATOR FOR MANUAL OPENINGS AND BEFORE ANY OTHER OPERATION, TO PREVENT DANGEROUS SITUATIONS. READ THE INSTRUCTIONS • IF THE POWER CABLE IS DAMAGED, IT MUST BE REPLACED BY THE MANUFACTURER OR THE TECHNICAL ASSISTANCE SERVICE OR BY A PERSON WITH A SIMILAR QUALIFICATION SO AS TO PREVENT ANY RISKS • IT IS STRICTLY FORBIDDEN FOR USERS TO PERFORM OPERATIONS THEY ARE NOT EXPLICITLY REQUIRED AND ASKED TO DO IN THE MANUALS. FOR REPAIRS, ADJUSTMENTS AND EXTRAORDINARY MAINTENANCE, CONTACT THE SPECIALIST TECHNICAL SERVICE CENTRE • ON THE PERIODIC MAINTENANCE LOG, NOTE DOWN THE CHECKS YOU HAVE DONE.

SPECIAL INSTRUCTIONS AND ADVICE FOR ALL

• AVOID WORKING NEAR THE HINGES OR MOVING MECHANICAL PARTS • STAY CLEAR OF THE GATE'S AREA OF OPERATION WHEN IN MOTION • DO NOT RESIST THE DIRECTION OF MOVEMENT OF THE GATE; THIS MAY PRESENT A SAFETY HAZARD • AT ALL TIMES BE EXTREMELY CAREFUL ABOUT DANGEROUS POINTS THAT MUST BE INDICATED BY PROPER PICTOGRAMS AND/OR BLACK AND YELLOW STRIPES • WHEN USING A SELECTOR OR COMMAND IN 'HOLD-TO-RUN' MODE, KEEP CHECKING THAT THERE ARE NO PEOPLE IN THE AREA OF OPERATION OF THE MOVING PARTS. DO THIS UNTIL YOU RELEASE THE COMMAND • THE GATE MAY MOVE AT ANY TIME WITHOUT WARNING • ALWAYS CUT THE POWER WHEN CLEANING OR PERFORMING MAINTENANCE.

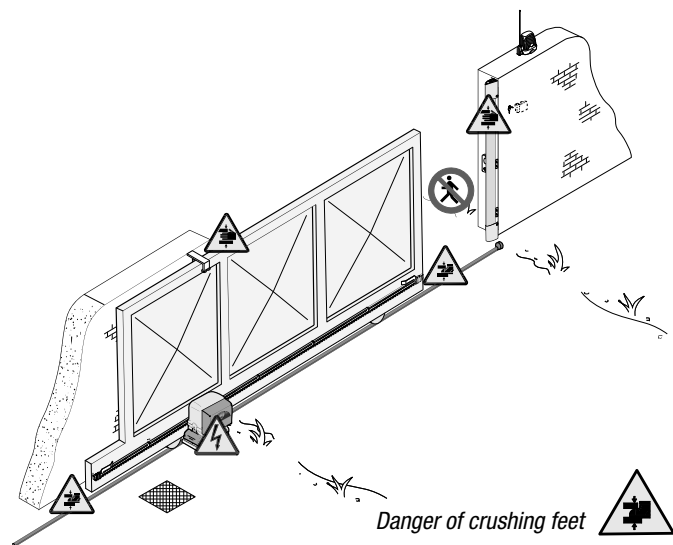

Danger of crushing feet



Danger of hand crushing



Danger - live parts



No transit during the manoeuvre



Legend of symbols



This symbol tells you to read the section with particular care.



This symbol tells you that the sections concern safety issues.



This symbol tells you what to say to the end-users.

THE MEASUREMENTS, UNLESS OTHERWISE STATED, ARE IN MILLIMETERS.

Conditions of use

Intended use

The BX246 operator is designed to power sliding gates in residential and condominium settings.



Do not install or use unless as otherwise shown in this manual.

Limitations to use

For intensive or condominium use: max gate weight 600kg with max gate length 18 m.

Description

Operator

This product is engineered and manufactured by CAME S.p.A. in compliance with current safety standards. The operator is made of a cast aluminium part inside of which operates the irreversible, electromechanical gearmotor and an ABS plastic lining which holds the electronic card, transformer and the clamp to house 2 emergency batteries.

Technical features

BX246 OPERATOR

Control panel power supply: 230V AC 50/60Hz

Operator power supply: 24V DC

Draw: 10 A

Power: 400 W

Reduction ratio: 1/33

Thrust: 700 N

Max speed.: 6÷12 m/min

Duty cycle: intensive use

Protection rating: IP54

Insulation class: I

Weight: 15 kg

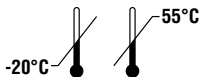

Description of parts

- 1 - Top cover
- 2 - Settings casing
- 3 - Control board support
- 4 - Endstop fins
- 5 - ZD2 electronic card
- 6 - Front cover to control panel
- 7 - Gearmotor release door
- 8 - Securing plate
- 9 - Securing bolt
- 10 - Securing screw plate
- 11 - Nut

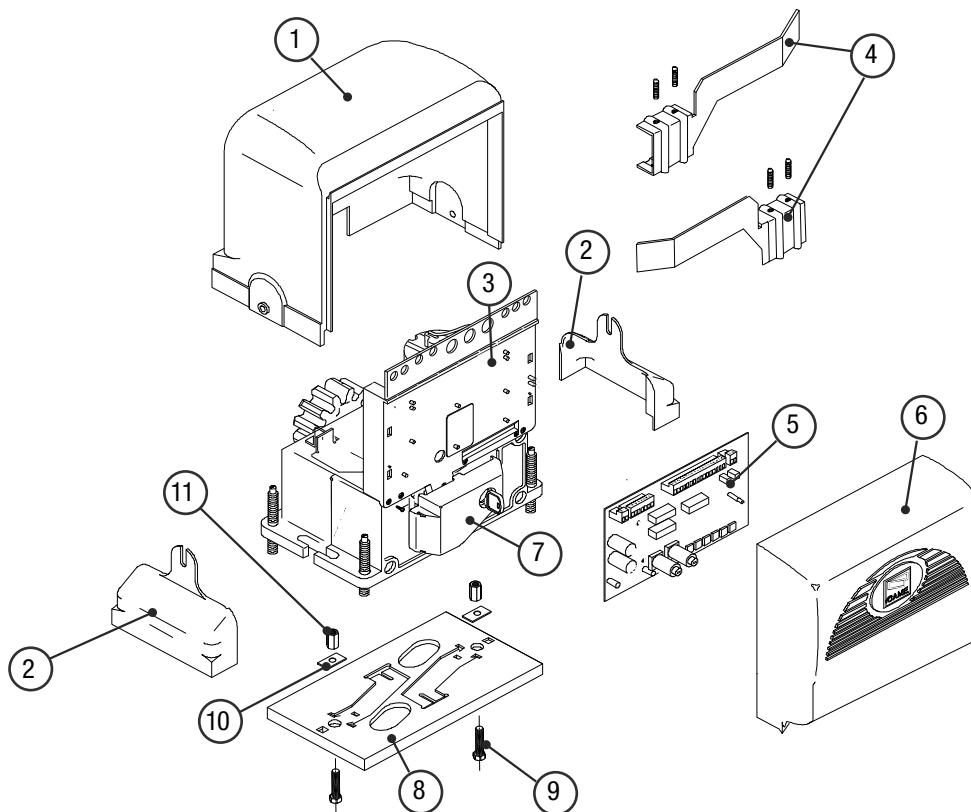

Dimensions

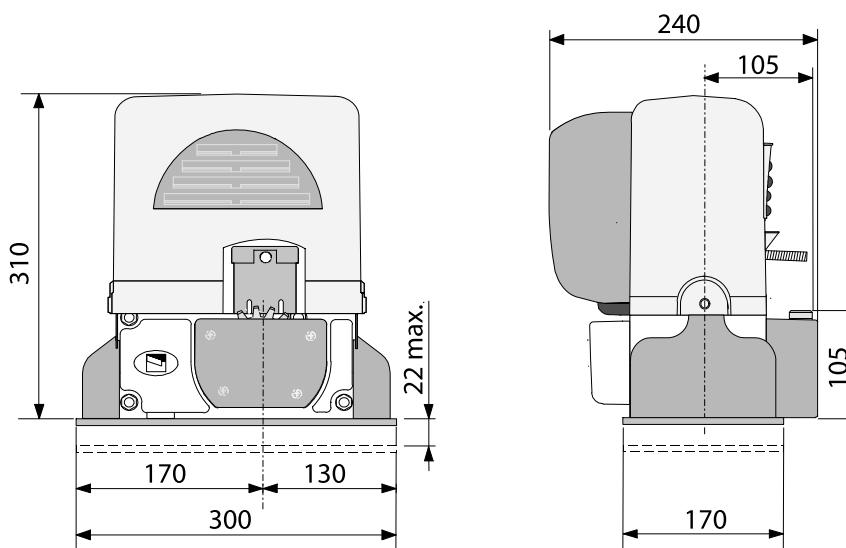

Installation

⚠ Installation must be carried out by expert qualified personnel and in full compliance with current regulations.

Preliminary checks

⚠ Before installing, do the following:

- Make sure that the gate is stable, and that the castors are in good working order and properly greased.
- The ground rack must be well secured to the ground, entirely above the surface and free of any irregularities that may obstruct the gate's movement.
- The upper guide rails must not create any friction.
- Make sure that there is a closing and an opening endstops.
- Make sure that the operator is attached to a solid surface and protected from any impacts;
- Make sure you have a suitable omnipolar cut-off device with contacts more than 3 mm apart, and independent (sectioned off) power supply;
- ⚡ Check that any connections inside the container (that provide continuity to the safety circuit) are fitted with additional insulation compared to other internal live parts;
- Make sure you have suitable tubing and conduits for the electrical cables to pass through and be protected against mechanical damage.

Cable list and minimum thickness

Connection	Type of cable	Length of cable 1 < 10 m	Length of cable 10 < 20 m	Length of cable 20 < 30 m
Control panel power supply 230V	FROR CEI 20-22 CEI EN 50267-2-1	3G x 1,5 mm ²	3G x 2,5 mm ²	3G x 4 mm ²
Flashing light		2 x 0,5 mm ²	2 x 1 mm ²	2 x 1,5 mm ²
Photocell transmitter		2 x 0,5 mm ²	2 x 0,5 mm ²	2 x 0,5 mm ²
Photocell receiver		4 x 0,5 mm ²	4 x 0,5 mm ²	4 x 0,5 mm ²
Accessories power supply		2 x 0,5 mm ²	2 x 0,5 mm ²	2 x 1 mm ²
Safety and control devices		2 x 0,5 mm ²	2 x 0,5 mm ²	2 x 0,5 mm ²
Antenna connection	RG58	max. 10 m		

N.B.: If the cable length differs from that specified in the table, then you must determine the proper cable diameter in the basis of the actual power draw by the connected devices and depending on the standards specified in CEI EN 60204-1.

For connections that require several, sequential loads, the sizes given on the table must be re-evaluated based on actual power draw and distances. When connecting products that are not specified in this manual, please follow the documentation provided with said products.

Standard installation

- 1) BX246 assembly
- 2) Rack
- 3) Reception Antenna
- 4) Flashing light
- 5) Keyswitch selector
- 6) Safety photocells
- 7) Electric cable junction box
- 8) Mechanical endstops
- 9) Guide rails
- 10) Endstop fins
- 11) Sensitive edge

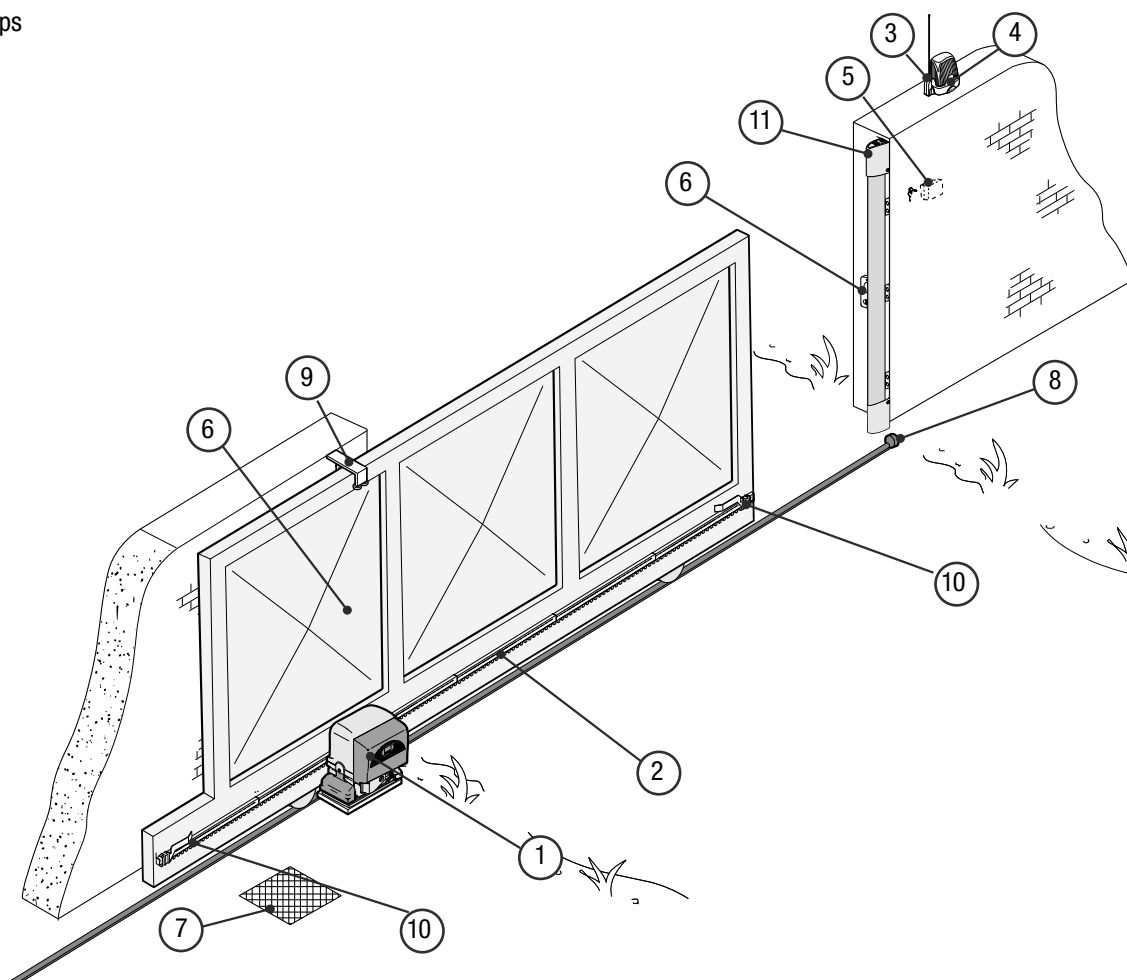

Securing the plate and installing the assembly

! The following applications are only examples, as the space for installing the ratiomotor and accessories varies according to obstructions. It is thus up to the system installer to select the most suitable solution.

- Dig a pit to the side of the gate (see measurements from diagram).
- Prepare the corrugated tubes you will need when making connections coming from the shunt pit.
- N.B. the number of tubes depends on the type of system and the accessories you will hook up.

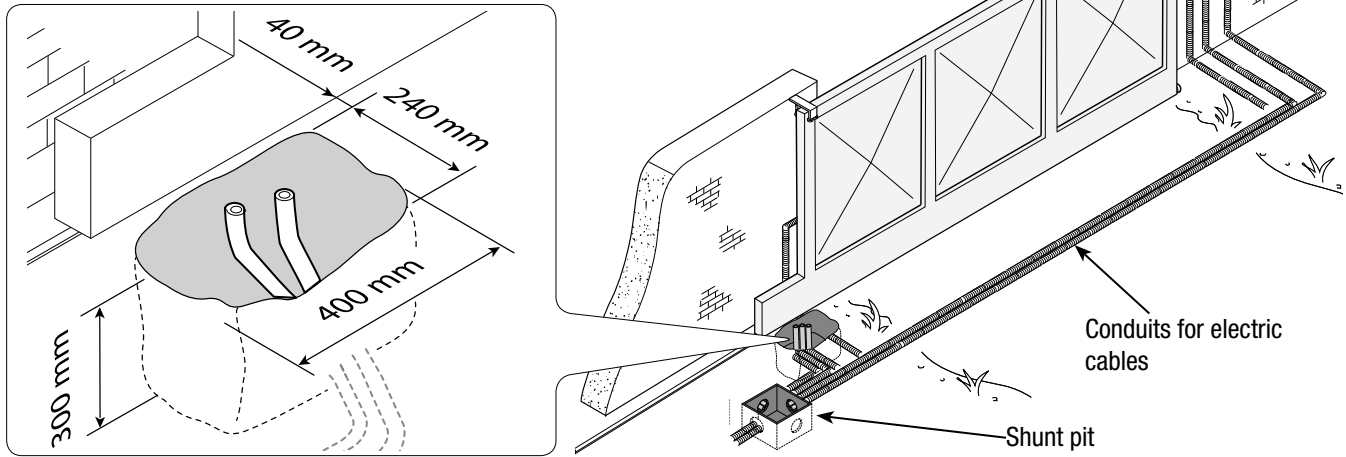

- Prepare a form box that is larger in size than the securing plate and insert it into the pit. The form box should jut 50mm above ground level.
- Insert an iron grid inside the from box to reinforce the concrete.

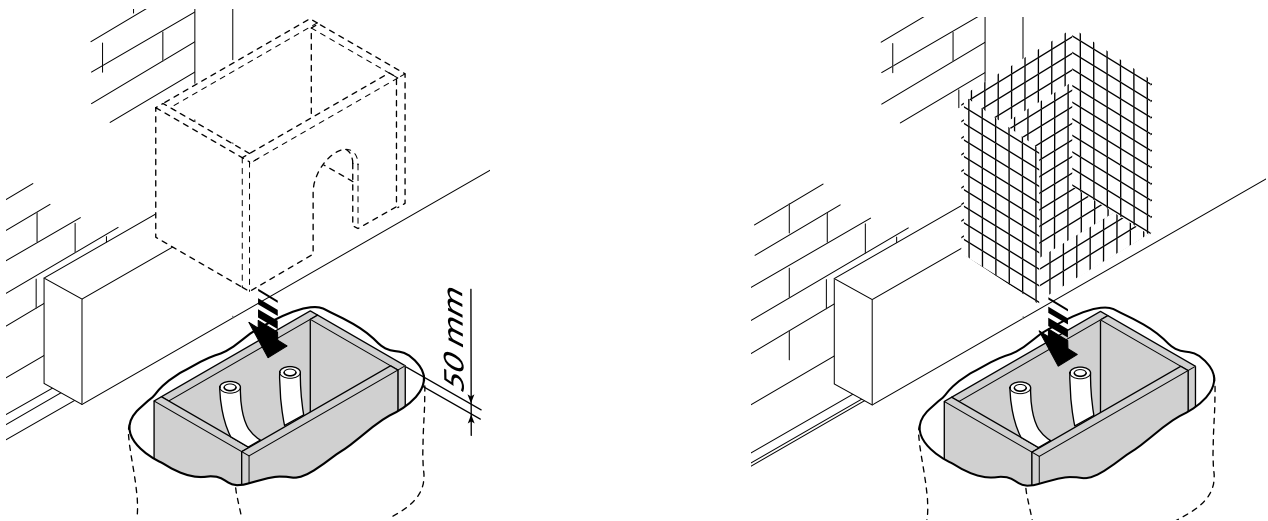

- Prepare the securing plate, insert the bolts into the holes and lock them using the supplied nuts and washers. Extract the preformed brackets using a screw driver or a set of pliers.
- Position the plate on top of the grid. Careful! The tubes need to pass through the apposite holes.

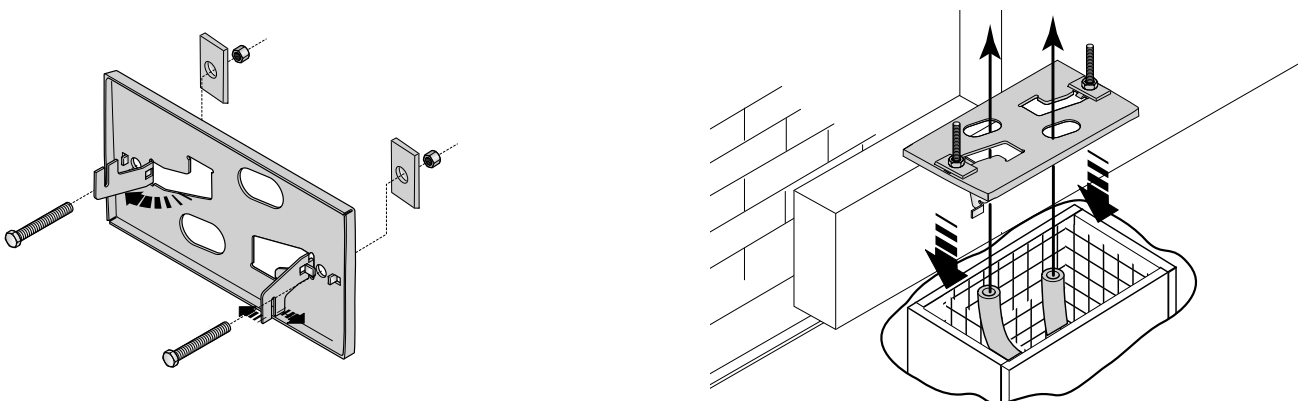

- To position the plate in relation to the rack please see the measurements on the diagram.
Fill the form box with cement and wait for at least 24 hours for it to solidify.

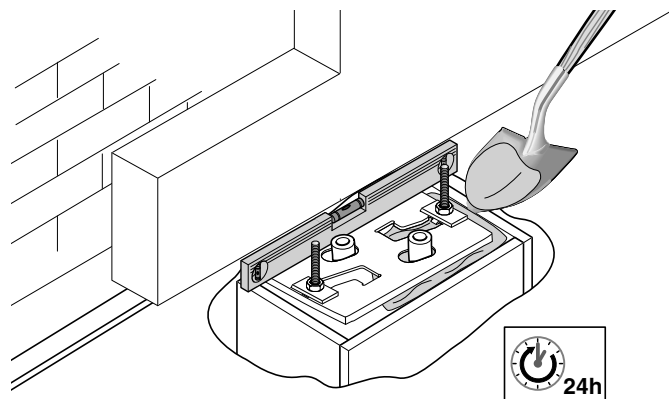
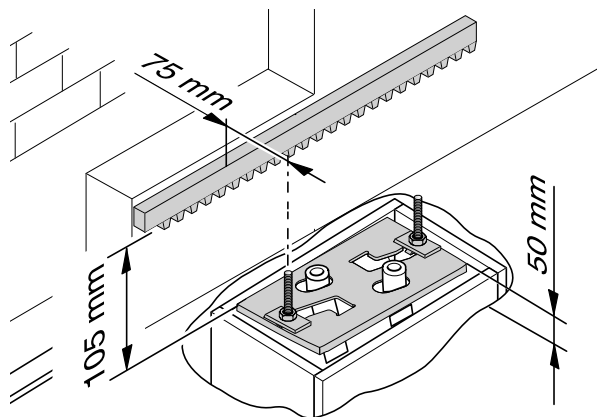

- Remove the form box, fill the pit around the cement block with soil.

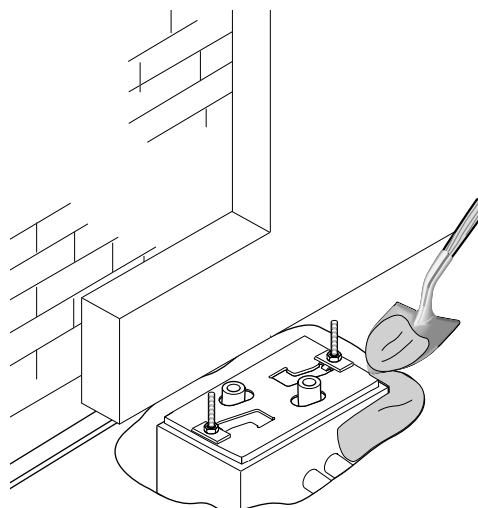
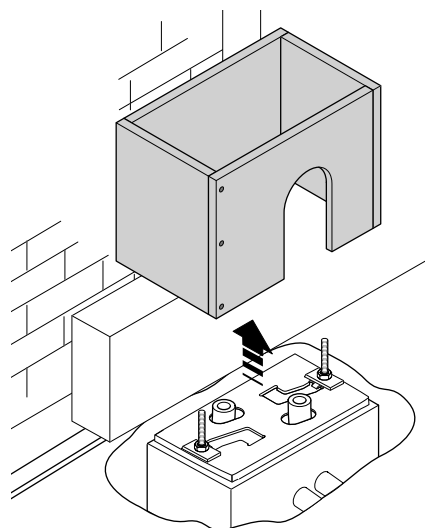

- Unbolt the nuts and washers from the bolts. The securing plate must be clean, perfectly aligned and with the bolt threads completely on the surface.
Insert the electric cables into the tubes until they exit about 400mm.

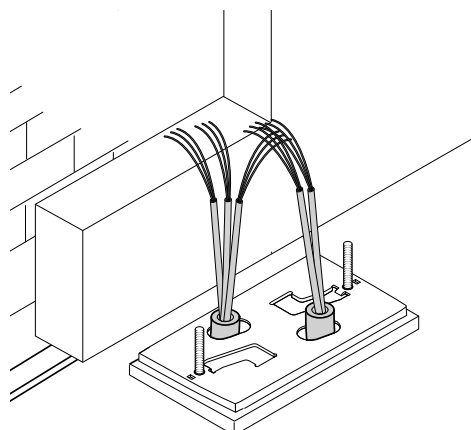
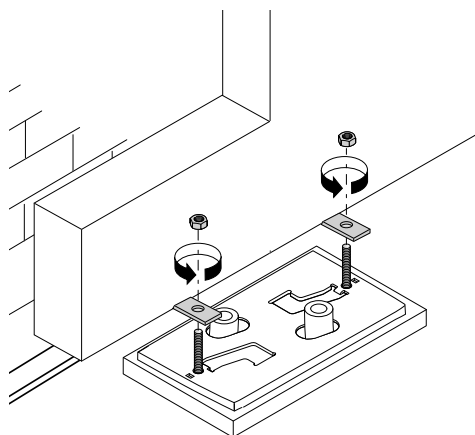

- Remove the cover from the gearmotor by loosening the side bolts, perforate the cable shafts using a screwdriver or a pair of scissors and position the gearmotor atop the plate. Careful! The electric cables must pass through the cable shafts.

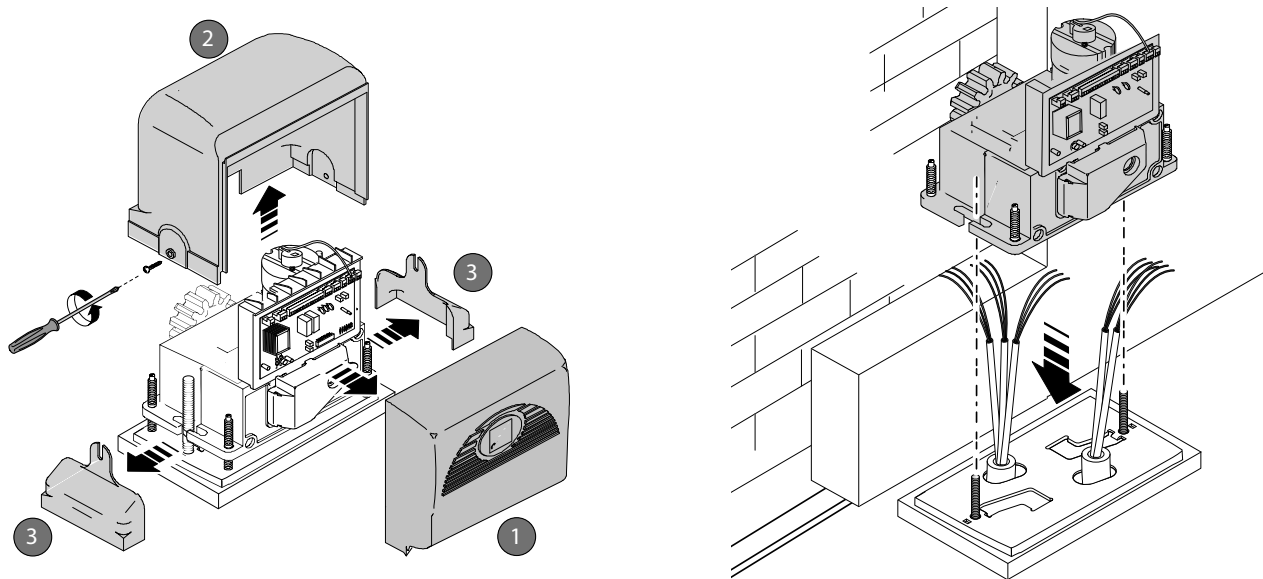

- Lift the gearmotor from the securing plate by about 5 to 10mm by using the threaded steel-levelling feet to allow any later adjustments between the pinion and the rack.

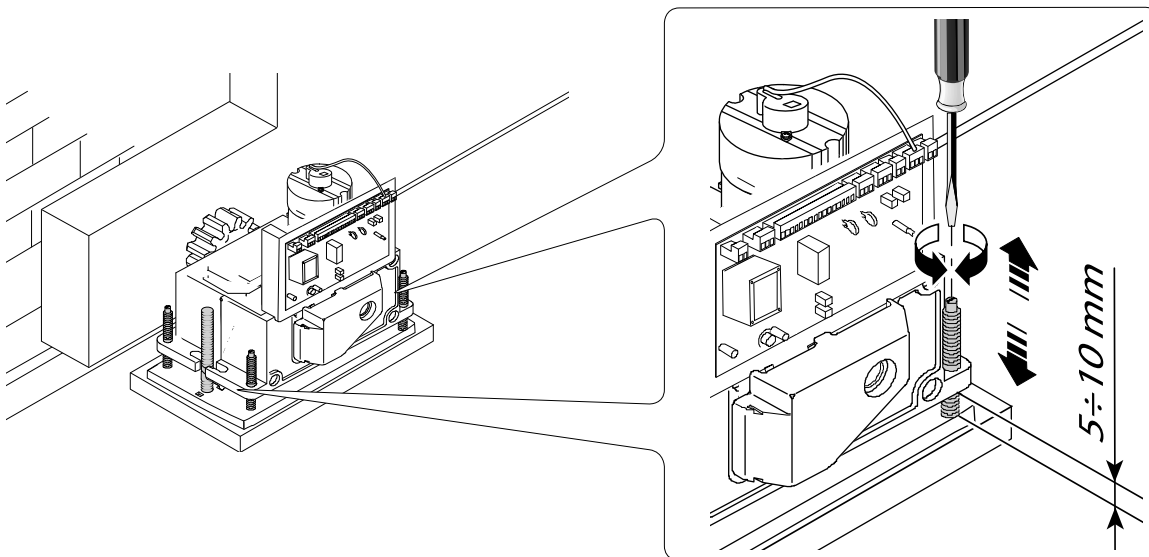

- The following illustrations for the securing the rack, are just examples of applications. It is up to the installer to choose the best solution.

Releasing the gearmotor (see paragraph on manual release). Rest the rack on the gearmotor pinion.

Weld or secure the rack to the gate along its entire length.

To assemble the rack modules, use an excess piece of rack and place it under the joining point, then block it using two C-clamps.

Note: if a rack is already in place, then just adjust the pinion-to-rack distance.

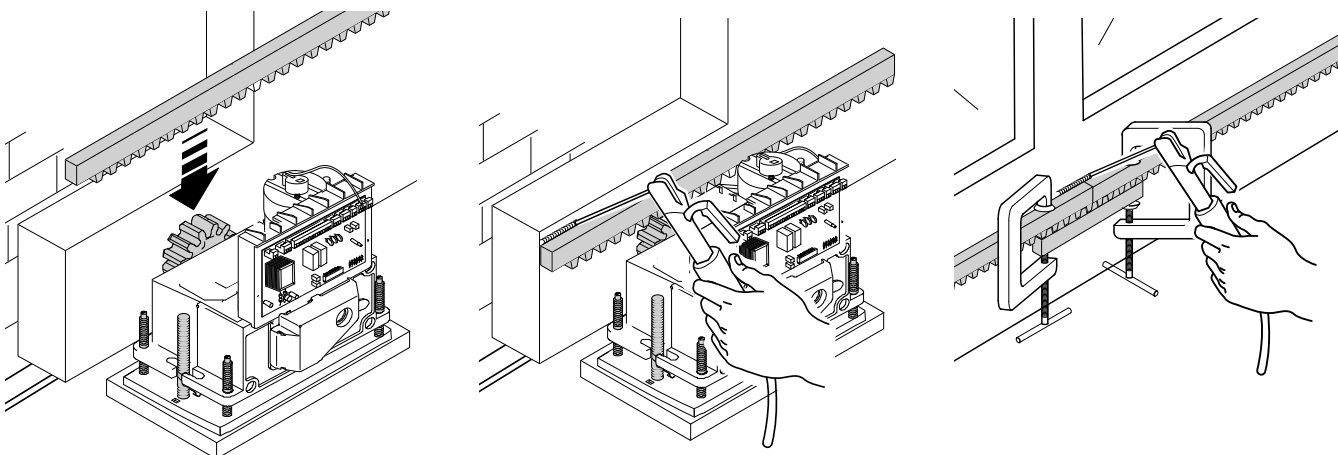

- Open and close the gate manually and register the pinion-to-rack distance using the threaded steel-levelling feet (for vertical adjusting) and the slotted holes (horizontal adjusting). This prevents the weight of the gate from bearing on the operator.

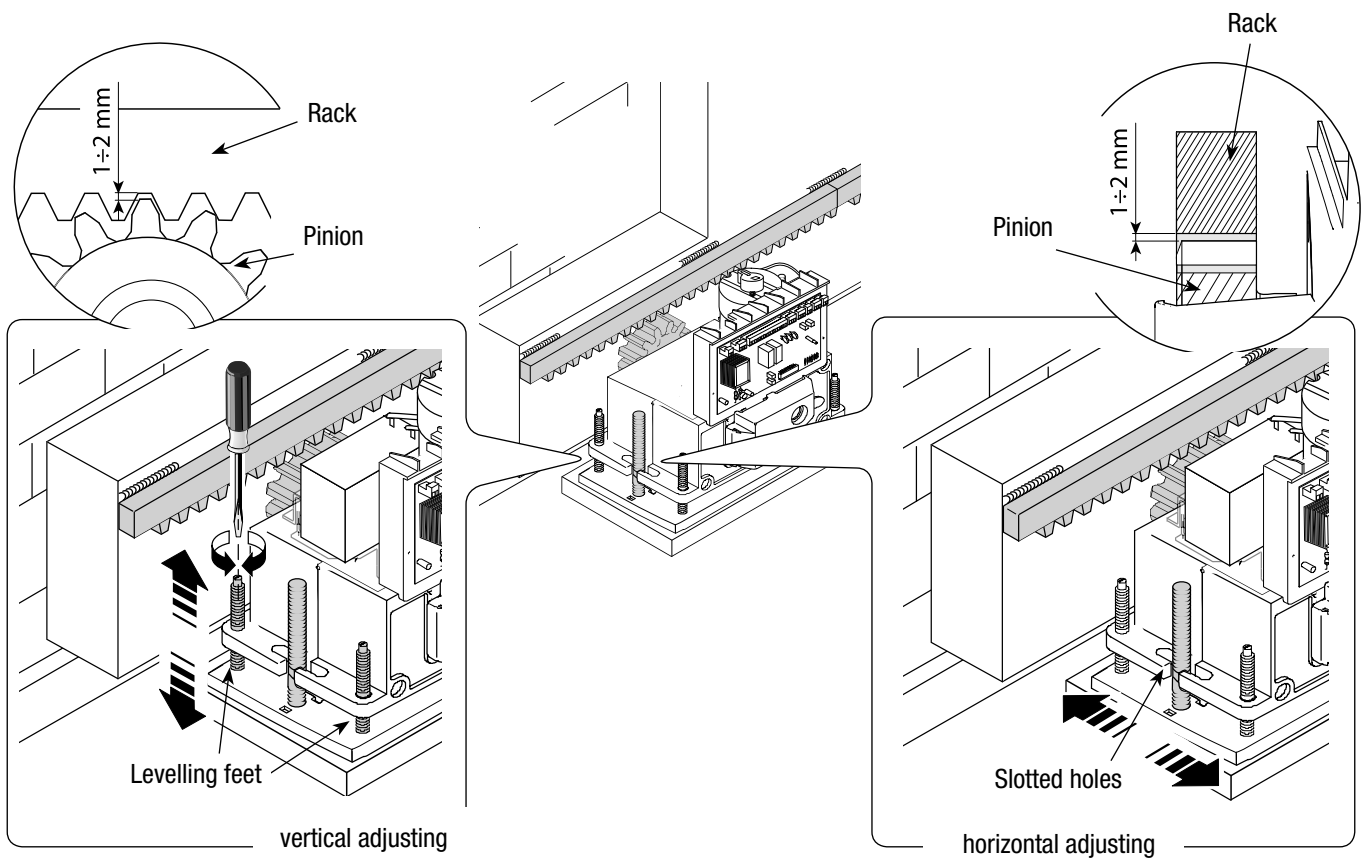

Once adjustments are finished, secure the assembly using the nuts and washers. Insert the cover after performing the adjustments and settings on the electronic card.

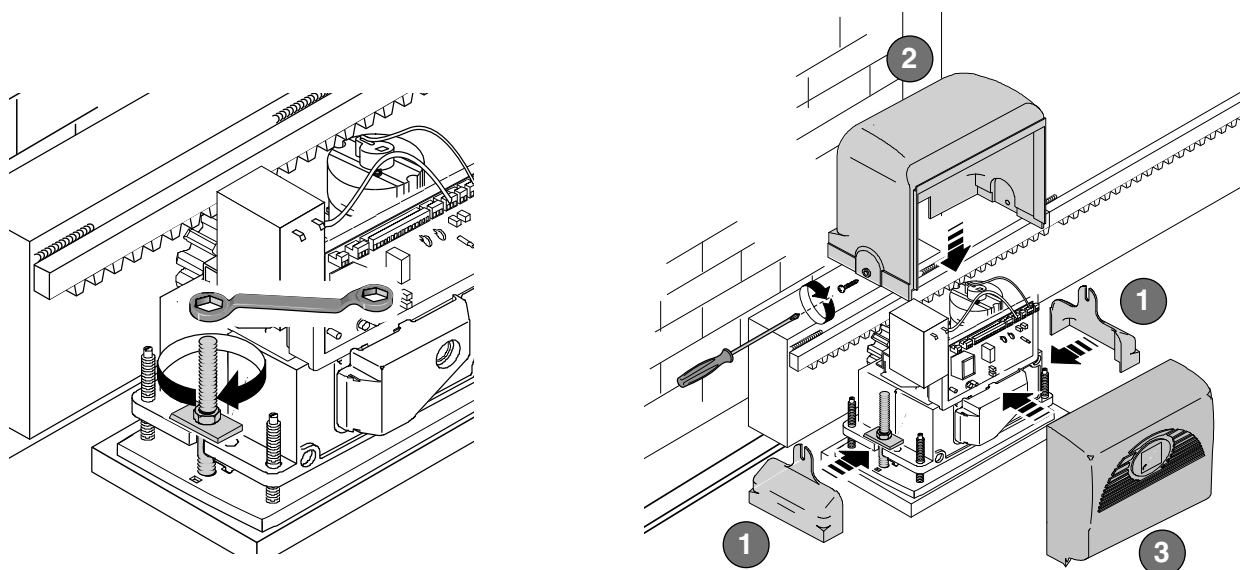

Mounting the endstop fins

Place the endstop fins onto the rack and secure them using a 3 mm Allen wrench. Their positioning limits the gate run.

Note: the gate should not slam against the mechanical stop, when opening or closing.

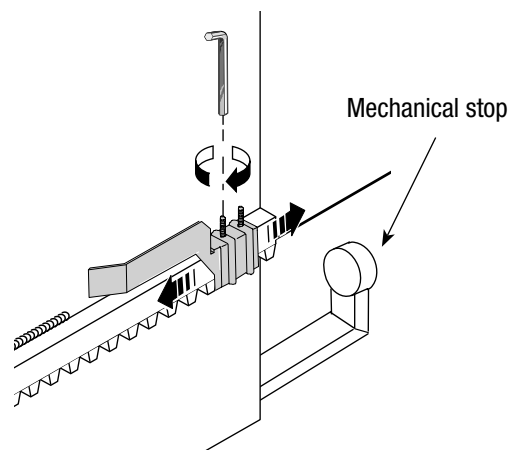
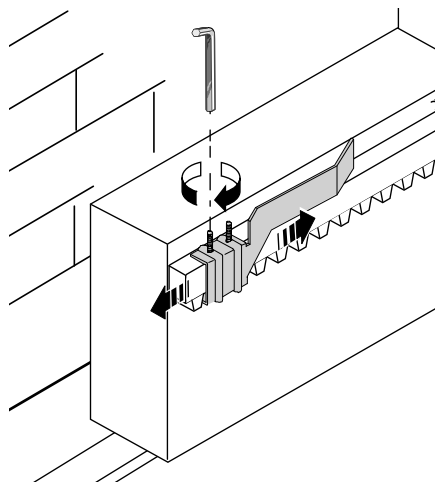

Manually releasing the gearmotor

- Insert the trilobed key into the lock, push it in and turn it clockwise

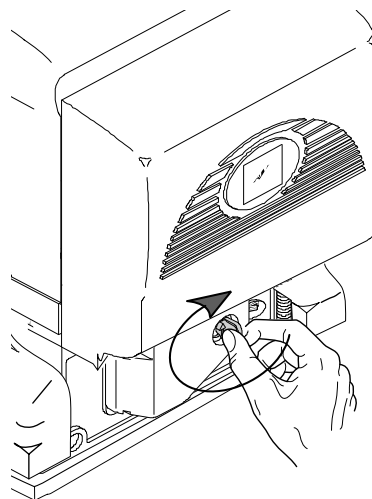
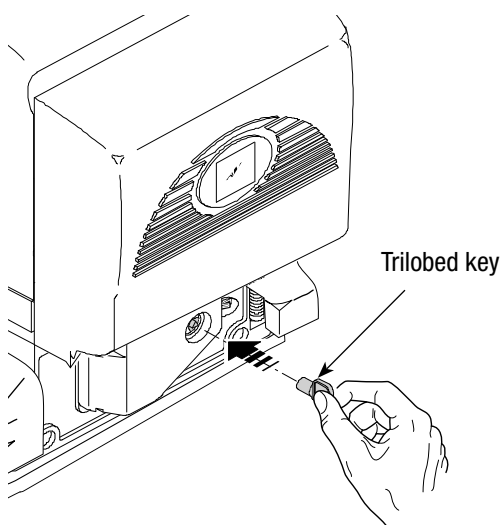

..... open the small door and turn the release handle clockwise.

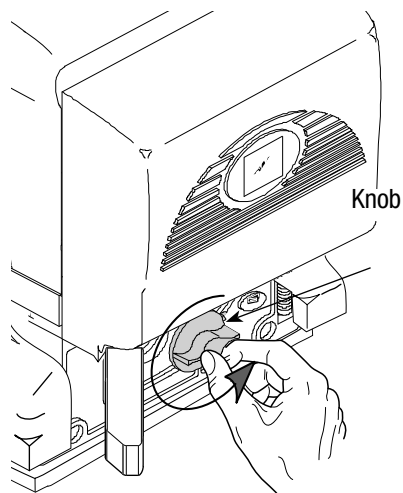

WARNING: opening the door will disengage the motor (i.e. it will not function). To operate the motor the release mechanism must be firmly fastened.

Control board

General description

Use 230V AC to power the electronic card using the L-N terminals, at a max 50/60Hz frequency.

Use 24V to power the command devices and accessories. Careful! The accessories cannot exceed 37W of overall power.

The card is fitted with an amperometric device which constantly monitors the motor's drive. When the gate runs into an obstacle, the amperometric sensor immediately detects the overload on the drive and so inverts the gate's movement:

- opens it if it is closing
- closes it if it is opening

Warning: after 3 obstacle detections, the gate stops when in opening-mode and excludes automatic-closing mode; to regain movement press the command button or use the remote control. All connections are protected by quick-fuses – see table.

The card handles the following functions:

- Automatic closing after an opening command;
- Warning light pre-flashing;
- Obstacle detection when gate is still at any point;
- Constant monitoring of photocell operations.
- Opening/closing;
- Opening/closing in maintained action mode;
- partial opening;
- total stop.

Apposite trimmers regulate:

- The automatic closing's running time;
- The partial opening;
- The amperometric device's detection sensitivity, in both normal and brake modes;
- the speed of both the normal gate run and the brake mode run.

Warning! Before acting on the machinery, cut off the main power supply and disconnect any emergency batteries.

TECHNICAL INFORMATION

Power supply	230V - 50/60 Hz
Maximum power allowed	400 W
Absorption at rest	100 mA
Maximum power for 24V accessories	35 W
Insulation rating	II

FUSE TABLE ZD2

To protect:	fuse:
Motor	10 A-F
Control board (line)	1,6 A-F
Accessories	1,6 A-F
Command devices	3,15 mA-F

Main components

- 1) Power supply terminals
- 2) Endstop terminals
- 3) Motor terminals
- 4) Encoder terminals
- 5) Accessory fuse
- 6) Card fuse
- 7) Button for memorising the radio code
- 8) Radio-code signalling LED indicator
- 9) 230V-power signalling LED
- 10) Control and signalling LED group
- 11) Function selector DIP switch
- 12) Socket for connecting the remote control's radiofrequency card
- 13) Antenna terminal
- 14) Accessories' and command device's terminals
- 15) Motor fuse
- 16) Line fuse
- 17) Setting trimmer
- 18) Battery charger (LBD2) connecting terminal boards
- 19) Transformer-connecting terminal board

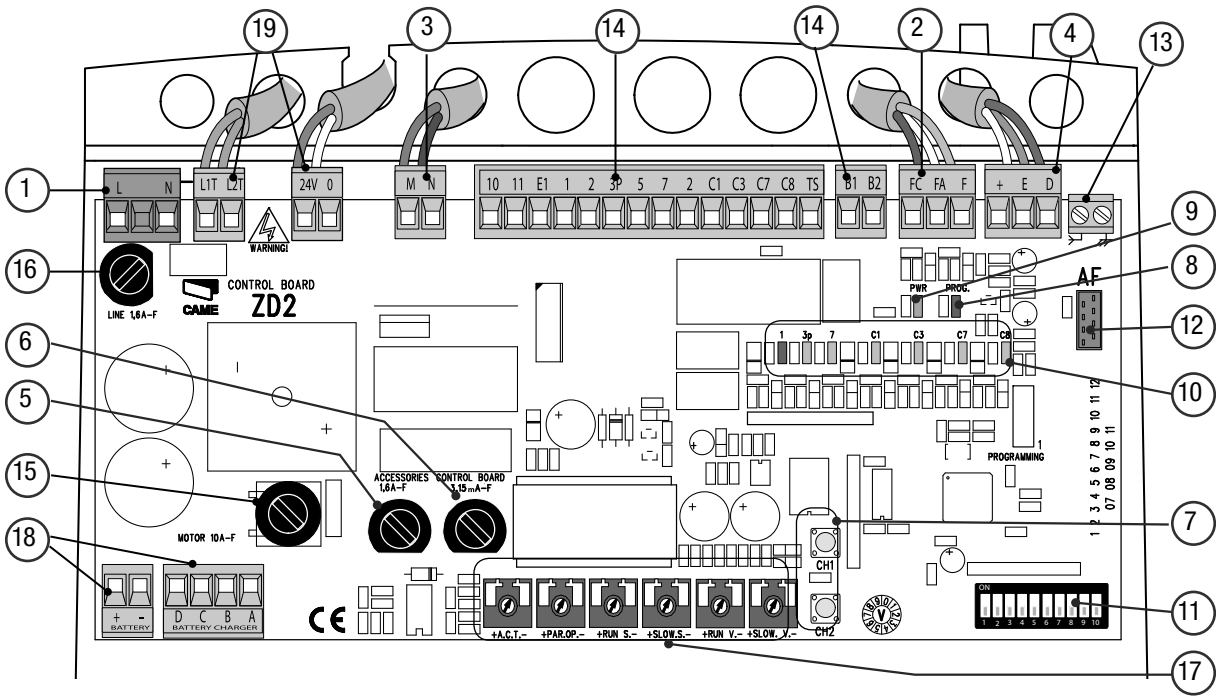

Electrical connections

Gearmotor, endstop and encoder

Description of the standard electrical connections for left-hand installations

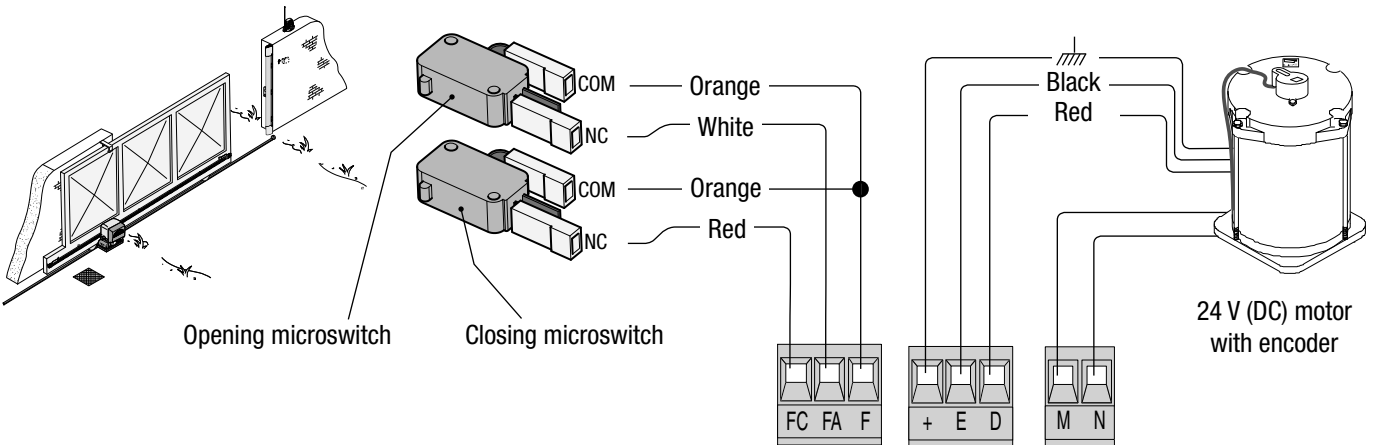

Modifications to the electrical connections for right-hand installations

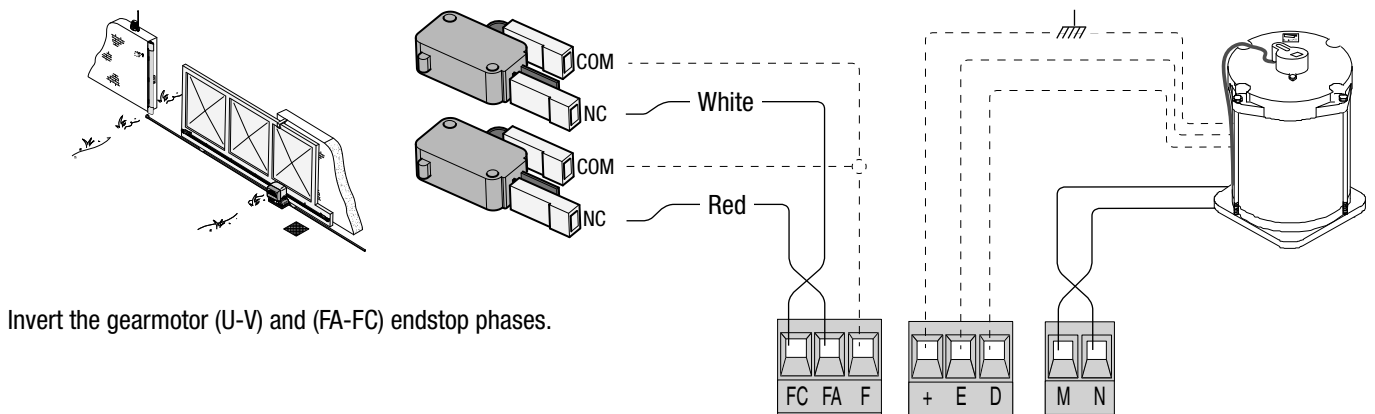

Power supply for accessories

Terminals for powering the following accessories:

- 24V AC normally;
- 24V DC when the emergency batteries are working;

Maximum allowed power: 35W

230V (AC) Power, 50/60Hz frequency

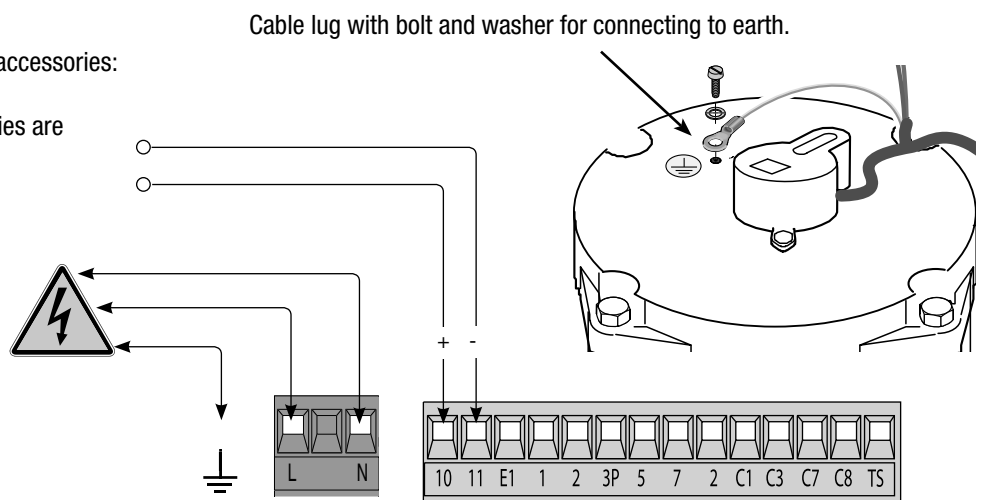

Warning devices

Movement flashing light (Contact range: 24V – 25W max) - Flashes during the gate's opening and closing phases.

Open-gate status light (contact range: 24V – 3W max) - Signal that gate is open; turns off when gate is closed.

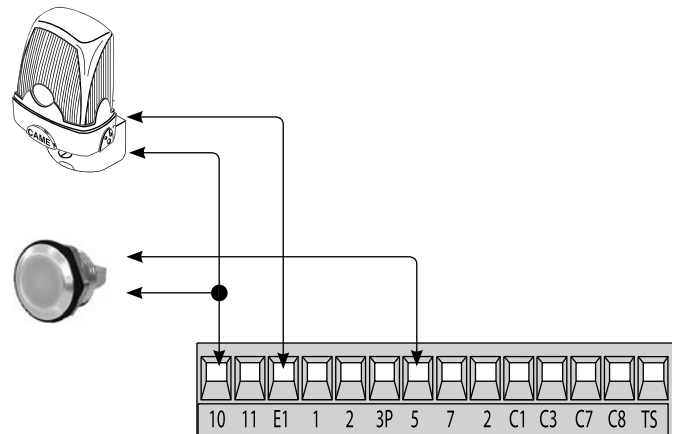

Command and control devices

Stop button (N.C. contact)

- Gate stop button. Excludes automatic closing. For motion to resume, press the command button or the remote control button.

Key selector and/or partial opening button (N.O. contact)

- Partial gate opening for pedestrian access.

Key selector and/or command button (N.O. contact)

- Gate opening and closing command.

By pressing the button or turning the selector key, the gate inverts its movement or stops depending on which the settings on the DIP switches.

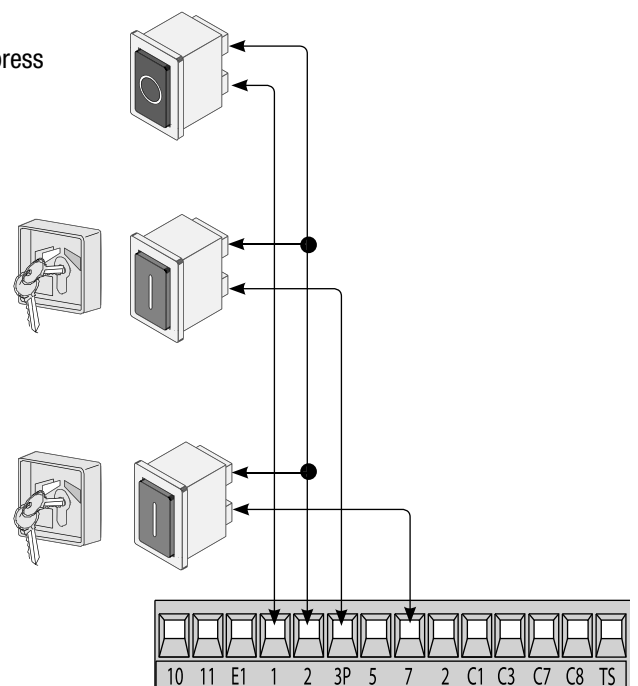

«partial stop» (N.C.) contact
 - Input for EN 12978 standard-compliant safety devices such as photocells. Gate stops if moving and automatically shuts (if this functions has been selected).

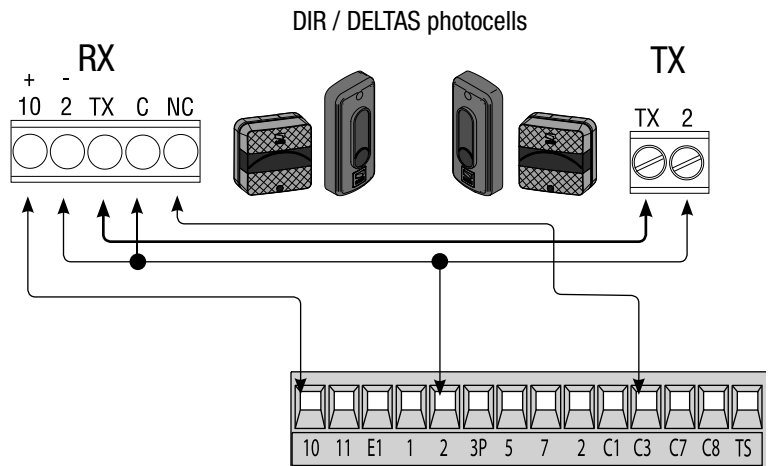

(N.C.) contact for «re-open during closing phase»
 - Input for EN 12978 standard-compliant safety devices such as photocells. If contact is opened, while gate is closing, the gate inverts its direction.

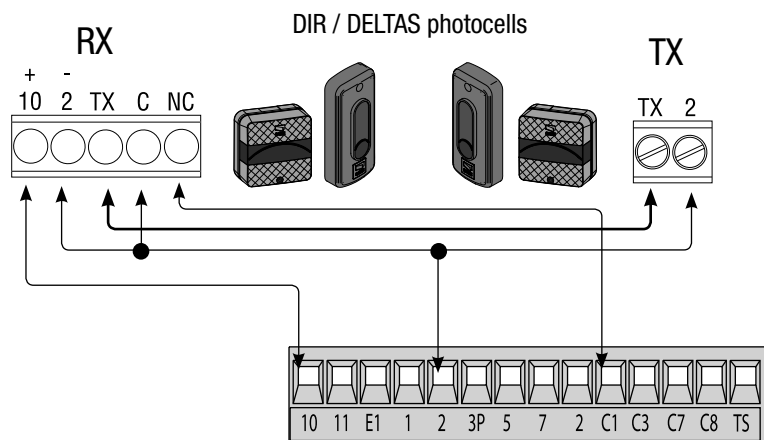

«partial stop» (N.C.) contact

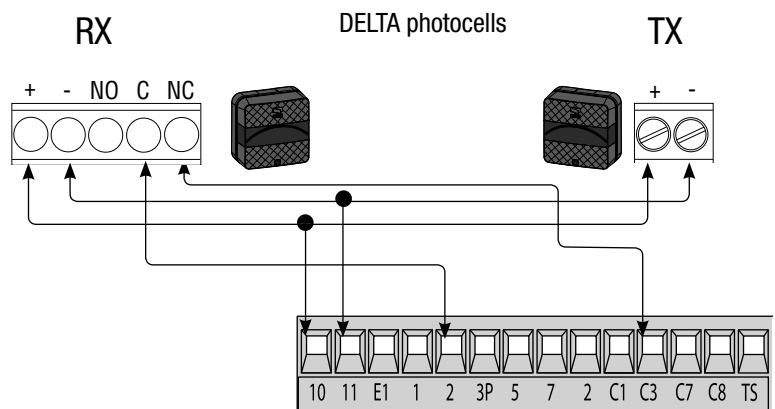

«Open while closing» (N.C.) contact

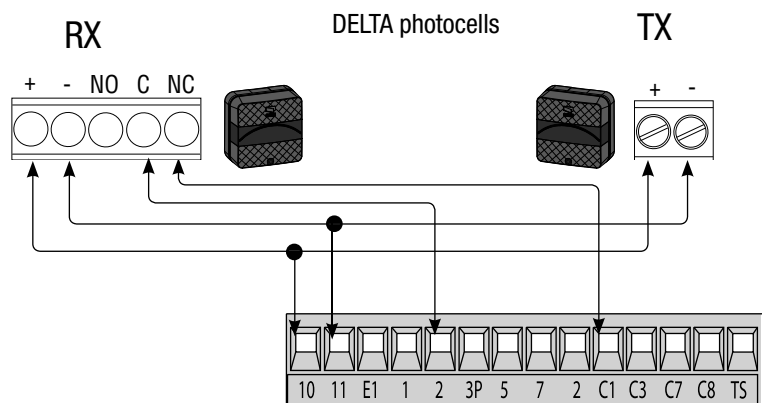

«Open while closing»(N.C.) contact
 - input for EN 12978 compliant safety devices such as sensitive edges. During gate closing, opening the contact causes inversion of movement until gate is fully open; if not used, short circuit contact 2-C7.

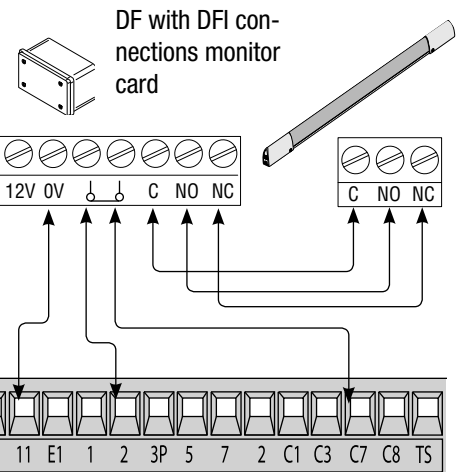
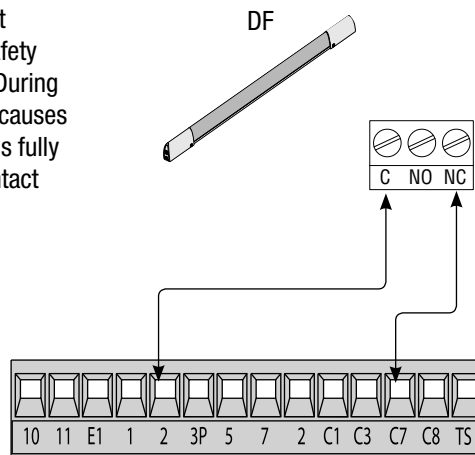

«Close while opening» (N.C.)contact
 - input for EN 12978 compliant safety devices such as sensitive edges. During gate opening, opening the contact causes inversion of movement until gate is fully close; if not used, short circuit contact 2-C8.

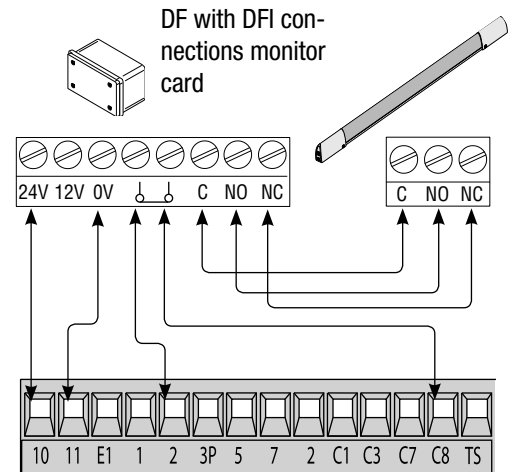
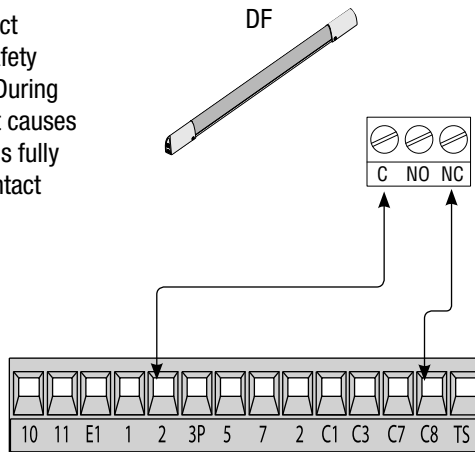

Electrical connection to operate the photocells' safety test

DELTA

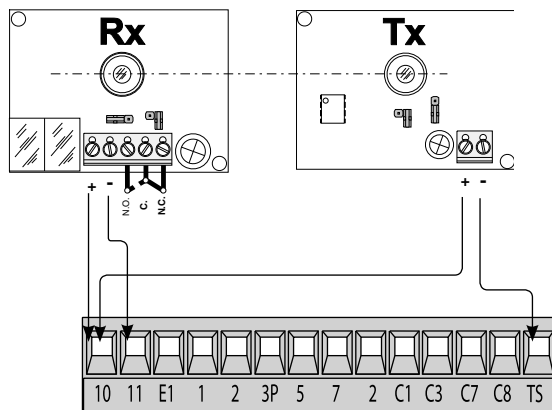

DIR / DELTAS

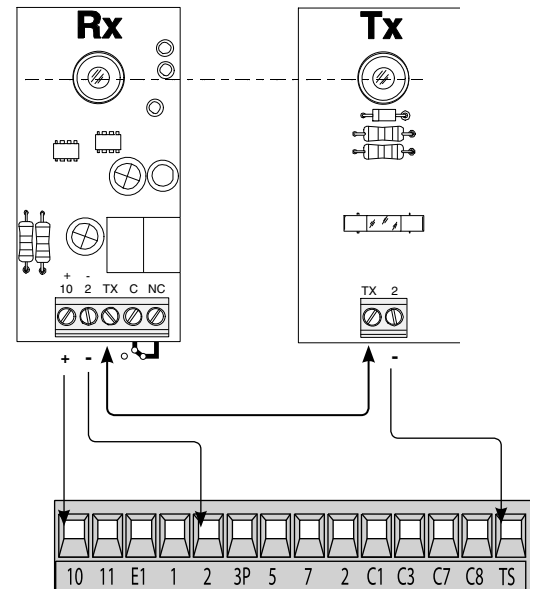

At each open/close command, the card check the photocells' efficiency. Any problems with the photocells will cause the (PROG) Led to flash on the electronic card, which cancels any commands from the radio transmitter or push-button.

Electrical connection to operate the photocells' safety test:

- The transmitter and receiver, must be connected as shown in the diagram;
- Set DIP switch 7 to ON to activate the test.

IMPORTANT:

When the safety test function is activated, the N.C. contacts:

- If unused – are to be excluded on their relative DIP switches (see chapter "selecting functions").

Function selector

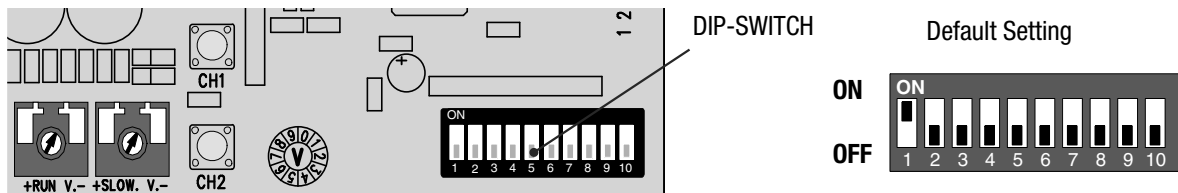

- 1 ON - Automatic Closing - The automatic closing timer activates at the end of the opening gate run. The pre-set time is adjustable, and is in any case conditioned by the activation of any safety devices, and does not activate after a total safety "stop" or during a blackout.
- 2 ON - "Open-stop-close-stop" function with [2-7] button and radio transmitter (fitted with inserted radiofrequency card).
- 2 OFF - "Open-close" function with [2-7] button and radio transmitter ((fitted with inserted radiofrequency card).
- 3 ON - "Open only" function with [2-7] button and radio transmitter ((fitted with inserted radiofrequency card).
- 4 ON - Pre-Opening and closing flasher - Following and opening and closing command, the flasher connected to [10-E1], flashes for 5 seconds before motion begins.
- 5 ON - Obstacle detected - When motor is stopped (gate closed or after a total stop command) it prevents any movement if safety devices, such as photocells, detect any obstacles.
- 6 ON - Maintained action - The gate works by keeping button pressed (one 2-3P opening button, and one 2-7 closing button).
- 7 ON - Functioning of the photocells' safety test - Allows the card to check the efficiency of any safety devices (i.e. photocells) after every opening or closing command.
- 8 OFF - Total stop - This function stops the gate and then excludes any automatic closing cycle; to set in motion again, use either the keypad or transmitter. Insert the safety device in [1-2]; if unused, set DIP switch to ON.
- 9 OFF - Opening during closing - If the photocells detect an obstacle during gate's closing, gate motion is inverted until fully opened; connect the safety device to terminals [2-C1]; if unused, set DIP switch to ON.
- 10 OFF - Partial stop - Gate stop when obstacle is detected by the safety device; once obstacle is removed, the gate remains still or closes if automatic closing is activated. Connect the safety device to terminal [2-C3]; if unused, set the DIP switch to ON.

Settings

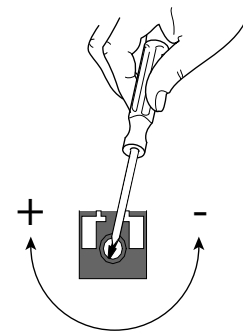
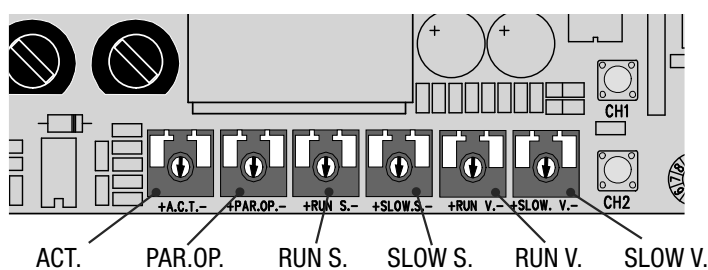

SETTING TRIMMER LIST:

- «ACT.» Sets the waiting time while open. Once this time has elapsed, closing automatically takes place. The waiting time may be set from 1 to 150 seconds.
- «PAR.OP.» Sets the gate's partial opening. By pushing the partial opening button connected at 2-3P, the gate opens depending on the length of the gate.
- «SLOW S.» Sets the amperometric sensitivity that controls the force generated by the motor during slow down; if the force exceed the set level, the system intervenes by inverting the direction of motion.
- «RUN S.» Sets the amperometric sensitivity that controls the force generated by the motor during movement; if the force exceeds the set level, the system intervenes by inverting the direction of motion.
- «SLOW V.» Sets the gate's final opening/closing phase slow-down speeds.
- «RUN V.» Sets the gate's opening/closing motion speed.

Warning Led

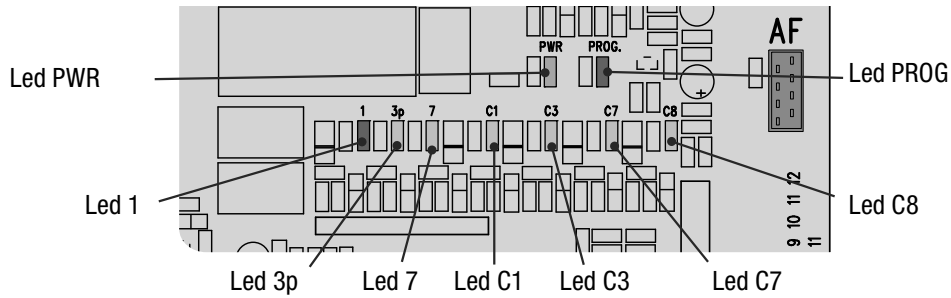

LIST WARNINGS OF THE COMMAND AND SAFETY DEVICES' CONTROL LEDs:

- «PROG» Red Led. Normally off.
When the transmitter is activating, it turns on or flashes.
- «PWR» Green led. Normally on.
Shows that card is properly powered;
- «1» Yellow led. Normally off.
Shows activation of the PARTIAL STOP button.
- «3p» Yellow Led indicator. Normally off.
Indicates that the PARTIAL OPENING button has been activated.
- «7» Yellow Led indicator. Normally off.
Indicates that the OPENING and CLOSING button has been activated.
- «C1» Yellow led. Normally off.
Shows that there are obstacles between the photocells (which are in OPEN WHILE CLOSING mode).
- «C3» Yellow Led. Normally off.
Shows that there are obstacles between the photocells (which are in PARTIAL STOP mode).
- «C7» Yellow Led. Normally off.
Show obstacles detected by the sensitive edge (which are in OPEN WHILE CLOSING mode).
- «C8» Yellow Led. Normally off.
Shows obstacles detected by sensitive edge (which are in CLOSE WHILE OPENING mode).

Programming to save gate-run and decelerations adjustments

Do the adjustment by making the operator execute a complete opening/closing manoeuvre
The control board automatically registers the gate-run adjustments with opening and closing decelerations.

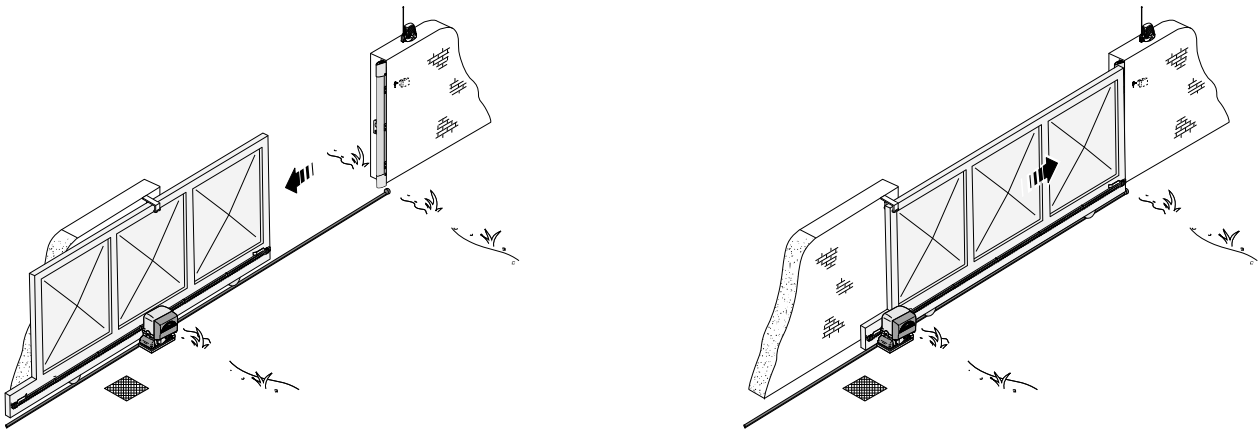

To save the adjustment, position dip **6** in **ON** and press **CH1** button until the signalling led stays on.
Re-position the dip in **OFF**

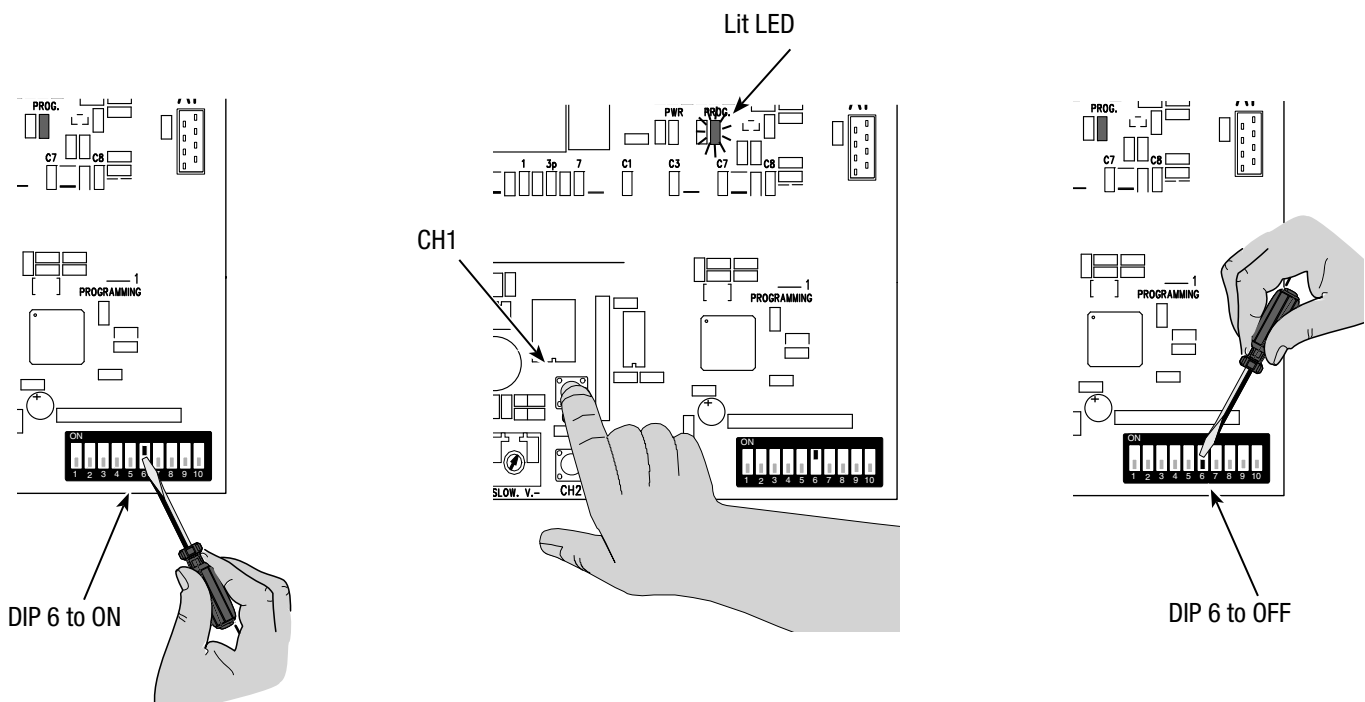

Activating the radio control

A Connect the antenna's RG58 cable.

⚠ Cut off the main power supply, and remove any batteries.

B Fit the AF board onto the electronic board.

📖 The electronic board recognizes the AF board only when the operator is powered up again.

C Keep the CH1 button on the electronic board pressed: the warning LED flashes.

D Press any button on the transmitter to send the code: the LED will stay on to let you know that the code has been stored. Repeat **C/D** for any other transmitter buttons.

📖 For a direct command to an accessory device connected on B1-B2, use channel CH2 **E**.

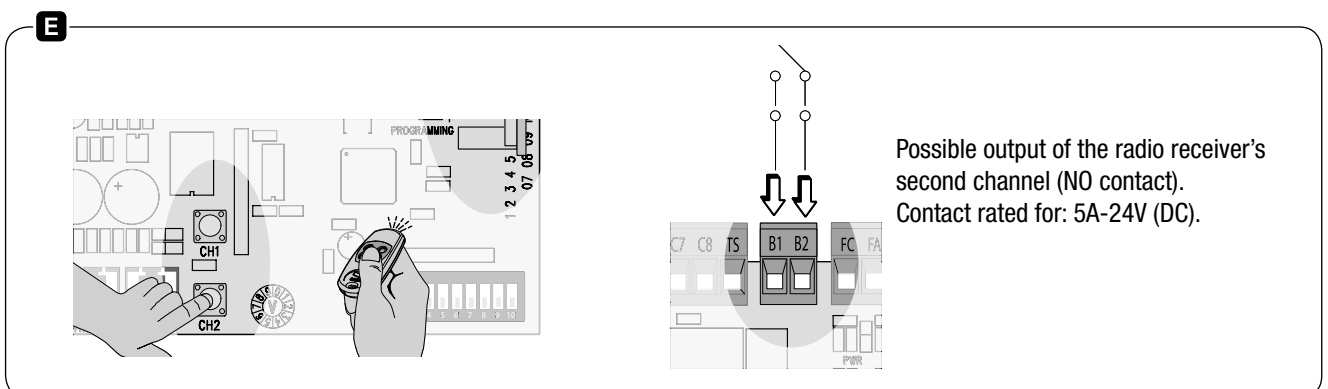
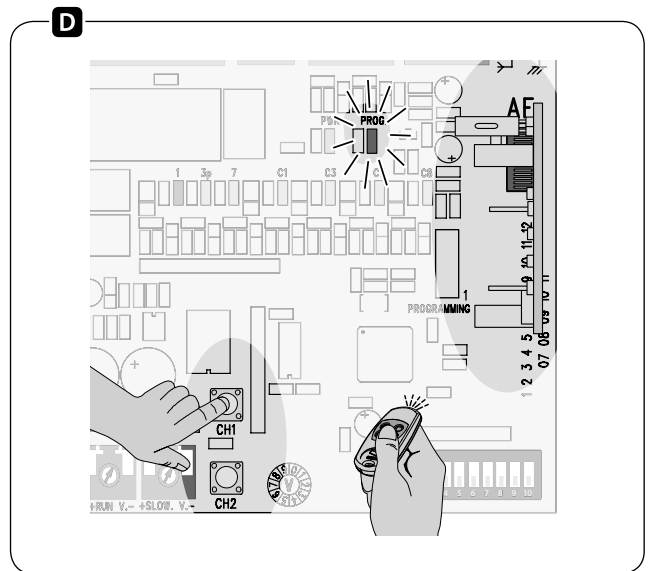
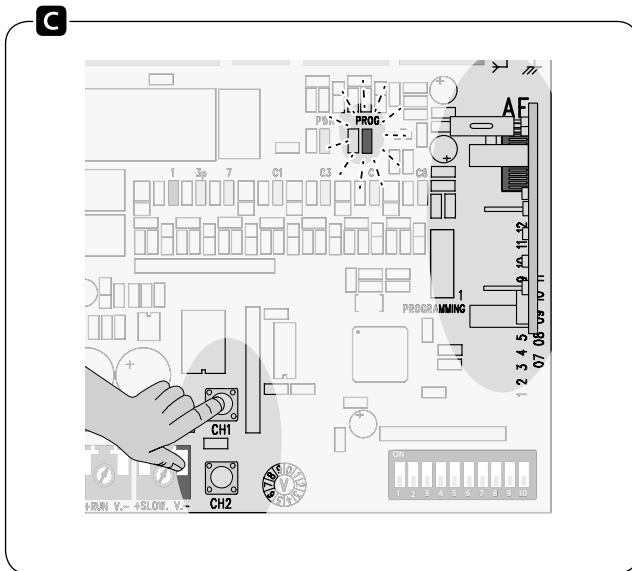
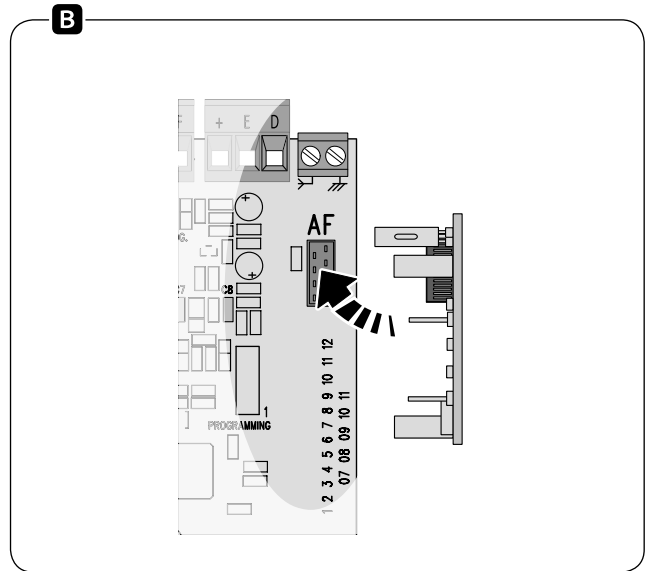
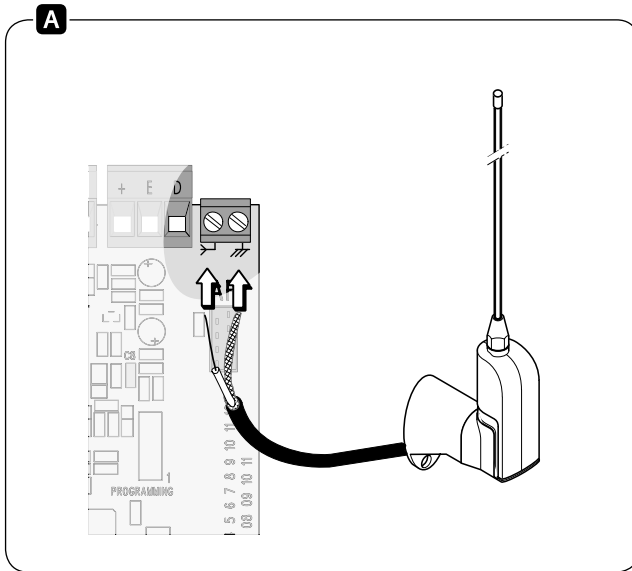

Connecting two coupled gearmotors having a single control

With two coupled gearmotors, you can command only the opening (by button and/or radio control): the gate will close only in automatic closing mode.

- Coordinate the direction of travel of the two gearmotors **A** and **B**, by modifying the motor's rotation **B** (invert the cables on terminals FA-FC and M-N).

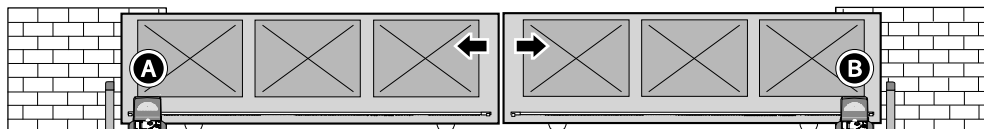

- Make the electrical connections only on the motor's control board **A**.

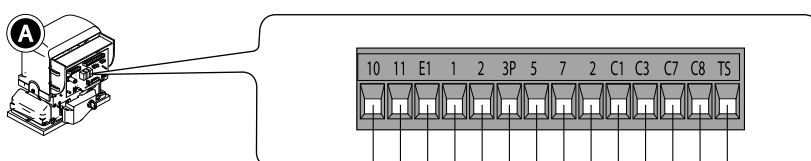

- Whereas, the adjustments and features, must be made on both boards.

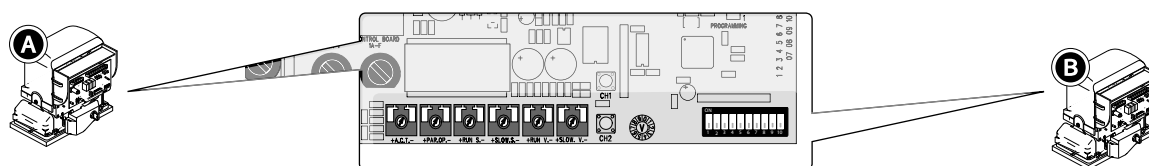

- Connect the two boards together, as illustrated.

- Set DIP 2 and 1 to ON on both boards.



For opening with a radio control, connect an external receiver (RExxx/RBExxx with relay in MONOSTABLE mode) on terminals 2-7 of the motor **A**.

Trouble shooting

MALFUNCTIONS	POSSIBLE CAUSES	CHECK AND REMEDIES
The gate will not open nor close	<ul style="list-style-type: none"> • There is no power • The gearmotor is in release mode and the release door is open • The transmitter's batteries are run down • The transmitter is broken • The stop button is either stuck or broken • The opening/closing button or the key selector are stuck • Photocells in partial stop mode 	<ul style="list-style-type: none"> • Check that the power is up • Call assistance • Replace batteries • Call assistance • Call assistance • Call assistance • Call assistance
The gate opens but will not close	<ul style="list-style-type: none"> • The photocells are engaged • Sensitive edge triggered 	<ul style="list-style-type: none"> • Check that photocells are clean and in good working order • Call assistance
The gate closes but will not open	<ul style="list-style-type: none"> • Sensitive edge triggered 	<ul style="list-style-type: none"> • Call assistance
The flasher does not work	<ul style="list-style-type: none"> • The bulb is burnt 	<ul style="list-style-type: none"> • Call assistance

Extra-ordinary maintenance

 The following table serves to note down any extraordinary maintenance, repairs or improvements performed by specialised firms. N.B.: Any extraordinary maintenance must be performed by specialised technicians.

Extra-ordinary maintenance log

Installer's stamp	Operator name
	Date of job
	Technician's signature
	Requester's signature
Job performed _____ _____ _____	

Installer's stamp	Operator name
	Date of job
	Technician's signature
	Requester's signature
Job performed _____ _____ _____	

Installer's stamp	Operator name
	Date of job
	Technician's signature
	Requester's signature
Job performed _____ _____ _____	

Installer's stamp	Operator name
	Date of job
	Technician's signature
	Requester's signature
Job performed _____	

Installer's stamp	Operator name
	Date of job
	Technician's signature
	Requester's signature
Job performed _____	

Installer's stamp	Operator name
	Date of job
	Technician's signature
	Requester's signature
Job performed _____	

Demolition and disposal

 **CAME S.p.A.** implements an EN ISO 14001 certified and compliant Environmental Management System at its plants, to ensure environmental protection.

Please continue our efforts to protect the environment, something that CAME considers to be one of the foundations in developing its business and market strategies, simply by observing brief recommendations as regards disposal:

DISPOSAL OF PACKAGING

Packaging components (cardboard, plastic etc.) can be disposed of together with normal household waste without any difficulty, by simply separating the different types of waste and recycling them.

Before proceeding, it is always advisable to check specific regulations in force in the place of installation.

DISPOSE OF PROPERLY!

DISPOSAL OF THE PRODUCT

Our products are made with different materials. Most of them (aluminium, plastic, iron, electrical cables) can be disposed of together with normal household waste. They can be recycled if collected, sorted and sent to authorised centres.

Other components (circuit boards, remote control batteries etc.), on the other hand, may contain pollutants.

They should therefore be removed and handed over to companies authorised to recover and recycle them.

Before proceeding, it is always advisable to check specific regulations in force in the place of disposal.

DISPOSE OF PROPERLY!

Reference regulations

The product complies to the reference regulations in effect.

English - Manual code: **FA00668-EN v. 1** - 02/2017 - © Came S.p.A.
The contents of this manual may be changed at any time without prior notice.

CAME
safety&comfort

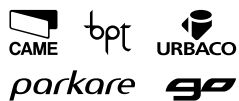

Came S.p.A.

Via Martiri Della Libertà, 15

31030 **Dosson di Casier**
Treviso - Italy

📞 (+39) 0422 4940

📠 (+39) 0422 4941

Via Cornia, 1/b - 1/c

33079 **Sesto al Reghena**
Pordenone - Italy

📞 (+39) 0434 698111

📠 (+39) 0434 698434

www.came.com