

L8542022
Rev. 02/01/00

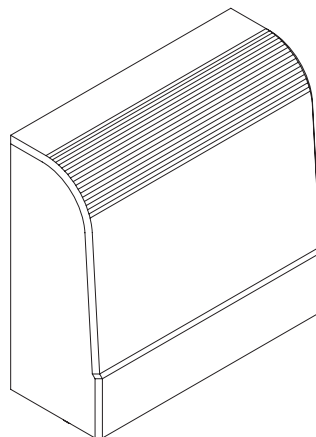

CENTRALINA
CONTROL PANEL
STEUEREINHEIT
CENTRALE
CENTRALITA

DA.90S/SP



Libro istruzioni
Operating instructions
Betriebsanleitung
Livret d'instructions
Libro de instrucciones



UNIONE NAZIONALE COSTRUTTORI
AUTOMATISMI PER CANCELLI, PORTE,
SERRANDE ED AFFINI

Dichiarazione CE di conformità
EC declaration of conformity
EG-Konformitätserklärung

Déclaration CE de conformité
Declaracion CE de conformidad

Con la presente dichiariamo che il nostro prodotto
We hereby declare that our product
Hiermit erklären wir, dass unser Produkt
Nous déclarons par la présente que notre produit
Por la presente declaramos que nuestro producto

DA.90S/SP

è conforme alle seguenti disposizioni pertinenti:
complies with the following relevant provisions:
folgenden einschlagigen Bestimmungen entspricht:
correspond aux dispositions pertinentes suivantes:
satisface las disposiciones pertinentes siguientes:

Direttiva sulla compatibilità elettromagnetica (89/336/
CCE, 93/68/CEE)
EMC guidelines (89/336/EEC, 93/68/EEC)
EMV-Richtlinie (89/336/EWG, 93/68/EWG)
Directive EMV (89/336/CCE, 93/68/CEE) (Compatibilité
électromagnétique)
Reglamento de compatibilidad electromagnética (89/336/
MCE, 93/68/MCE)

Direttiva sulla bassa tensione (73/23/CEE, 93/68/CEE)
Low voltage guidelines (73/23/EEC, 93/68/EEC)
Tiefe Spannung Richtlinie (73/23/EWG, 93/68/EWG)
Directive bas voltage (73/23/CEE, 93/68/CEE)
Reglamento de bajo Voltaje (73/23/MCE, 93/68/MCE)

Norme armonizzate applicate in particolare:
Applied harmonized standards, in particular:
Angewendete harmonisierte Normen, insbesondere:
Normes harmonisées utilisées, notamment:
Normas armonizadas utilizadas particularmente:

EN 55022, EN 61000-3-2, EN 61000-3-3, EN 50082-1

Norme armonizzate applicate in particolare:
Applied harmonized standards, in particular:
Angewendete harmonisierte Normen, insbesondere:
Normes harmonisées utilisées, notamment:
Normas armonizadas utilizadas particularmente:

EN 60204-1, EN 60335-1

Norme e specifiche tecniche nazionali applicate in
particolare:
Applied national technical standards and specifications, in
particular:
Angewendete nationale Normen und technische
Spezifikationen, insbesondere:
Normes et spécifications techniques nationales qui ont été
utilisées, notamment:
Normas y especificaciones técnicas nacionales que se
utilizaron particularmente:

UNI 8612

Data/Firma

Data/Firma



Automatismi Benincà Srl
Via Scamozzi, 3
36030 MONTECCHIO P. VI
ITALIA

Control panel DA.90S/SP

On the container, two separate push-buttons are present for the OPEN and CLOSE functions.

Installation instructions.

- a) The electrical installation must comply with current standards.
- b) Keep the power cables (for the motor and power supply) away from the control cables (buttons, photocells, radio). To avoid interference use two separate sheaths (see EN 60204-1 15.1.3).
- c) Check all the connections again before supplying voltage.
- d) If the direction of the motor rotation is not correct, invert the "OPEN" - "CLOSE" wires of the motor as well as the wires of the "FCA" - "FCC" limit switches.

Input/Output functions

- (1,2) Input, line 230Vac
- (3) To "APRE" terminal of the motor
- (4) To "CHIUDE" terminal of the motor
- (5) To "COMUNE" terminal of the motor
- (6,7) Output 24Vac - 250mA max.
- (8) Input, CHIUDE control with "man present" - 24Vdc
- (9) Input, APRE control with "man present" - 24Vdc
- (10) Output, common for APRE and CHIUDE inputs - 24Vdc

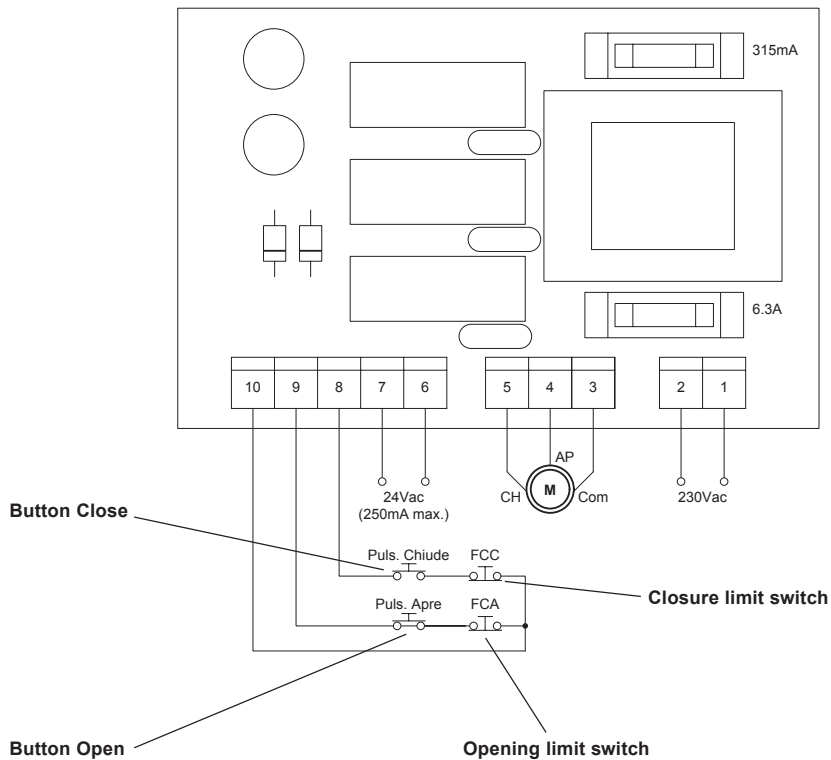



AUTOMATISMI BENINCÀ Srl - Via Capitello, 45 - 36066 Sandrigo (VI) - Tel. 0444 751030 r.a. - Fax 0444 759728
