

Complete kit for the automation of swinging gates
Instructions and Recommendations for installation and use



BEAUTY

SAVE YOUR ENERGY

BYOU

MADE IN ITALY **CE**

Dear Customer

We would like to congratulate and thank you for choosing the BYOU systems.

BEAUTY like all other products in the range it is the fruit of careful and accurate choice of materials and components. The result is a product that interprets and embodies captivating designs and state-of-the-art technology.

BYOU products are covered by a warranty with duration of 2 years.

BYOU is not liable for damage caused by improper use or by incorrect installation of products or components.

The descriptions and illustrations in this manual may be subject to modification at any time by the manufacturer, who reserves the right to make updates to the product of a technical, construction or commercial type, without having to update this publication within specific times.

For any information of a technical or commercial manner, contact:

**BYOU è un marchio di
AUTOMATISMI BENINCÀ SpA**

via Capitello, 45
36066 Sandrigo (VI) ITALY
Tel +39 0444 1510294
Fax +39 0444 759728
info@byouweb.com
www.byouweb.com

Index

General recommendations	3	Transmitter BY	15
Product description	3	Control unit CP.BTY connections	16
Content of the kit	4	Self-regulation of the functioning parameters (AUTO).....	17
Description of the automation	4	Programming the CP.JMP control unit - Introduction	17
Preliminary checks	5	Regulation of the motor thrust (PMOT)	18
Technical Data, dimensions and limits of use	5	Regulation of the automatic closure time (TCA)	18
Electric connections	6	Step-by-Step functioning mode (PP)	19
Tools and materials	7	Pre-flashing functioning mode (Pre).....	19
Choice of installation measurements - 1.....	7	Regulation of the phase shift time when closing (TDMC).....	19
Choice of installation measurements - 2.....	8	Condominium function (IBL)	20
Adjustable brackets BTY.1	8	Selection of the opening/closure speed (Sld).....	20
Fixing the gear motor brackets BTY.1	9	Resetting the control unit (Res)	20
Fixing the gear motor brackets BTY.2.....	10	Memorising new transmitters (RADI>PP).....	21
Regulation of mechanical opening and closing stops	11	Memorising pedestrian function (RADI>Ped)	21
Gear motors wiring.....	11	Deleting transmitters (RADI>CLR)	22
Fixing the CP.BTY control unit.....	11	Complete deletion of the receiver memory (RADI>RTR).....	22
Installation of the flashing light F.BY	12	Remote controls quick duplication	22
Installation of photocells P.BY.....	13	Inspection and commissioning.....	23
Installation of selector K.BY.....	14	What to do if... ..	24
Small columns C.BY.....	15	User guide	25

General recommendations

WARNING: Important safety instructions. Follow all instructions since incorrect installation can lead to severe injury.

If this is the first time you realise an automation for swing gates with Beauty, we recommend that you read this manual carefully as it contains important advice and information for the realisation of the plant in safe conditions.

Keep the various components on hand to gain confidence with them while reading this manual.

Keep this manual for future use.

BEAUTY is realised in a way to allow easy installation and configuration of the system, however, some phases require the presence of qualified staff.

When reading this manual pay particular attention to these symbols:



Authorised technician.

Indicates the phases to be performed in the presence of mains voltage. The presence of qualified staff is required (electrician or authorised installer), in complete respect with the Safety Standards in force.



Attention!

Potentially dangerous operations. Scrupulously respect the indications given.



Useful indication.

Suggestions and recommendations for simplifying and/or improving the installation operations.

The automation of a door cannot be considered the only device for protection against intrusion.

Do not use any of the components in unsuitable environments (salty, acid or potentially explosive atmosphere)

All operations that require the protection shells of the devices opened, must take place without mains power supply.

This item is not intended to be used by people (including children) with reduced physical, sensorial or mental abilities, or without adequate knowledge of the product, unless they are under the supervision of eligible persons or they have received instructions for use by people in charge of their security.

Check that the temperature range marked on the drive is suitable for the location.

The drive cannot be used with a driven part incorporating a wicket door (unless the drive cannot be operated with the wicket door open).

Ensure that entrapment between the driven part and the surrounding fixed parts due to the opening movement of the driven part is avoided.

After installation, ensure that the mechanism is properly adjusted and that the protection system and any manual release function correctly.

Product description

DESTINATION OF USE

This product is destined exclusively for the opening and closure of swing doors for the passage of vehicles, characterised by dimensional limits and weight as indicated in this manual in the "Limits of use" paragraph.

No other use is allowed.

BYOU is not liable for uses that are not in compliance with those indicated in these instructions.

The kit is made up from two electromechanical operators with 24V direct current motor, which allows movement of the leaves via a worm screw.

The control unit commands the movement of the two motors and the functioning of the various accessories.

The supplied accessories are:

- 1 P.BY pair of photocells: they interrupt the movement of the leaf if there are obstacles present.
- 1 F.BY flashing light: flashing light that indicates that the door is moving.
- 1 K.BY key selector switch: installed externally, allows the opening and closure by means of a customised key.
- 2 BY radio transmitters: remote control for opening/closing the door.

Other accessories available as options:

- CB.BY emergency battery kit: in case of a power cut, it allows the functioning of the leaf by batteries and relative battery charger installed inside the operator.
- C.BY pair of small columns for additional pair of photocells F.BY: to be installed within the property (see paragraph C.BY).

Content of the kit

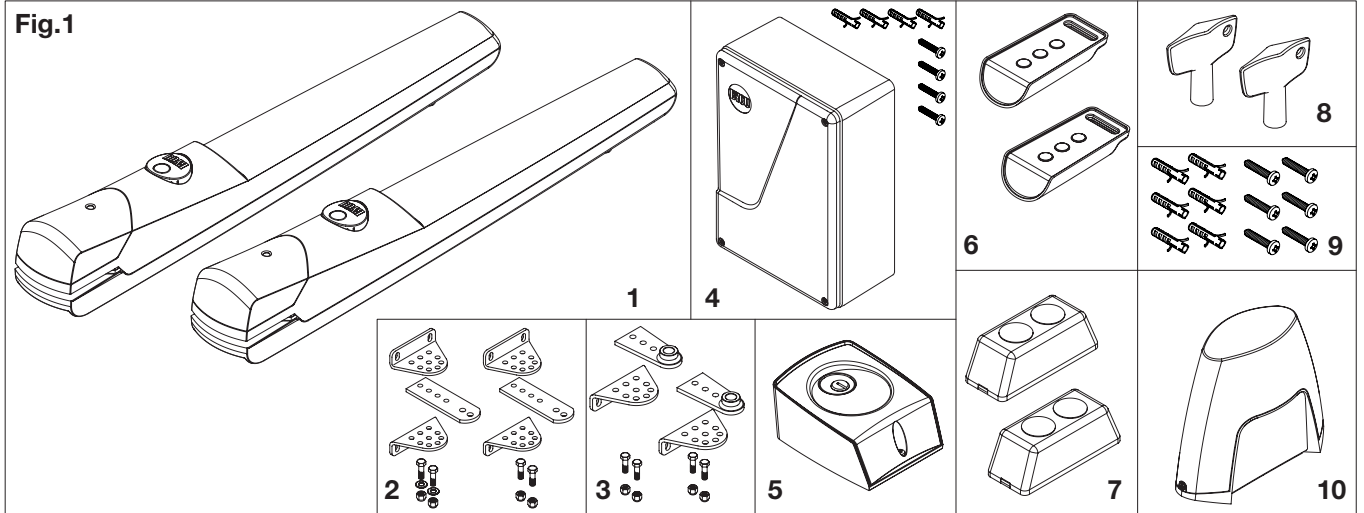

1	BEAUTY: Pair of electromechanical operators.
2	BTY.1: Pair of pillar fixing brackets with screws and bolts.
3	BTY.2: Pair leaf fixing brackets with screws and bolts.
4	CP.BTY: Control unit with plugs and screws.
5	K.BY: Key selector.
6	BY: Pair of 4-channel radio transmitter.

7	P.BY: Pair of photocells for wall installation 1 transmitter ("TX") 1 receiver ("RX")
8	BTY.3: Release keys for manual manoeuvre
9	Plugs and screws for fixing the accessories (flashing light, key selector, photocells)
10	F.BY: Flashing light with built-in aerial

Note: The content of the package may undergo variations. If in doubt, consult your local dealer.

Description of the automation

With reference to the list of components in fig. 1, fig. 2 shows a typical plant that can be realised using BEAUTY.

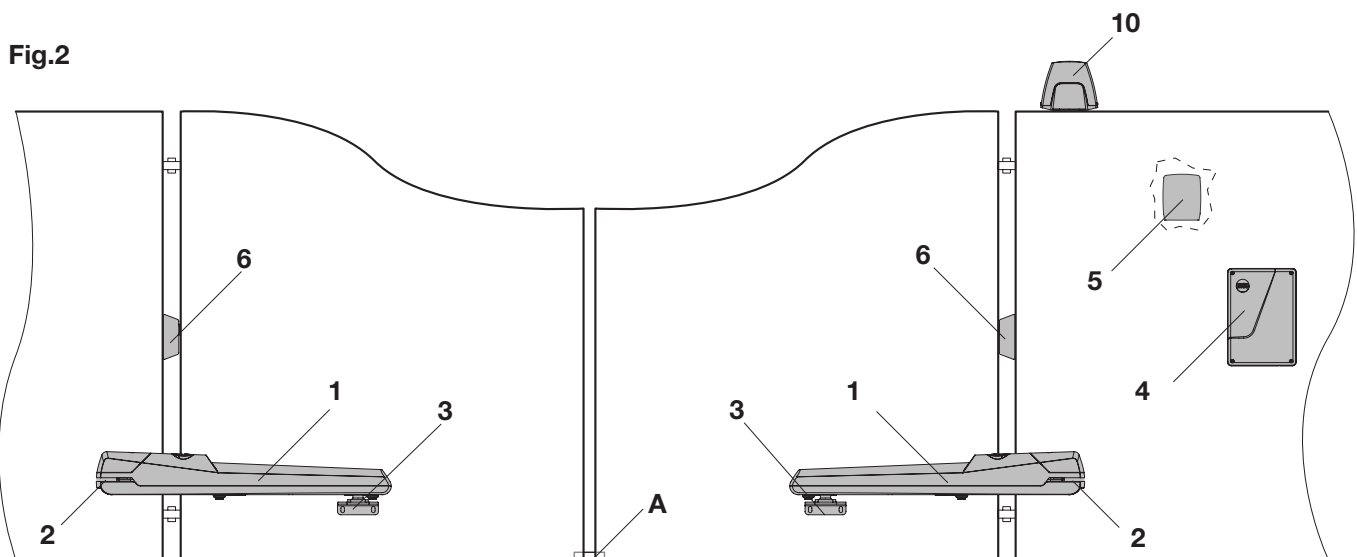

Preliminary checks

It is indispensable to carry out several checks before starting installation:

- Try and open the gate manually, the leaves must move without effort and without points of resistance for the entire run.
- When left in any intermediate position the leaf must not move.
- The hinges and components subject to wear must be in perfect working condition. If this is not the case, replace the faulty parts.
- The door structure must be strong and the leaves rigid.
- With the gate completely closed, check that the leaves are aligned perfectly along their entire length.
- The electric set-ups necessary for installation are highlighted in the "Electric connections" paragraph. If they are not pre-existing they must be realised, with the aid of a specialised technician, if necessary (electrician).
- The pillars supporting the leaves must be suitable for fixing the gear motors.

- Beauty has adjustable mechanical stops both in opening and closing. However, a stop for closure on the ground is recommended (Fig.2-ref.A).



The reliability and safety of the automation depend on the state of the gate structure.



Check that there is enough space for installation of the operator in safe and comfortable conditions.

Technical Data, dimensions and limits of use

TECHNICAL DATA

	BEAUTY
Control unit power supply	230 Vac
Motor power supply	24Vdc
Absorbed power	80 W
Maximum current absorbed	3,5 A
Maximum thrust	1500 N
Maximum frequency of use (complete opening/closure cycles)	15 cycles/hour 80 cycles/day
Protection rating	IP44
Functioning temperature	-20°C / +70°C
Opening time (90°)	12/18 s
Run	300 mm
Noise	<70 dB
Weight	4,2 kg

LIMITS OF USE

Table 1 indicates the maximum values in the grey area (weight by leaf length) acceptable for the BEAUTY automation

For example:

200 kg and 1.55 m leaf

It lies within the limits of use (black dotted line)

270 kg and 1.80 m leaf:

It DOES NOT lie within the limits of use (white dotted line)

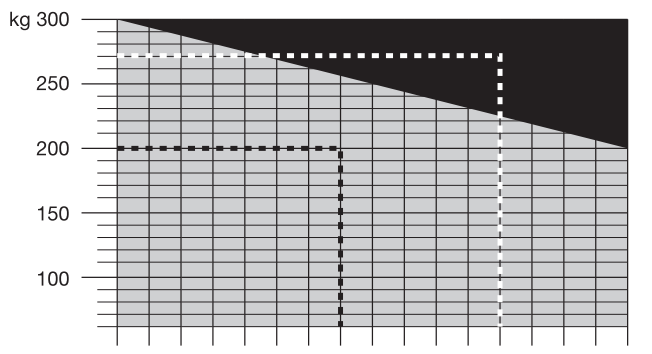

Tab. 1

DIMENSIONS

Fig.3 indicates the main overall dimensions.

The measurements are expressed in millimetres.

The 300 mm measurement represents the maximum run that the rod can make during movement.

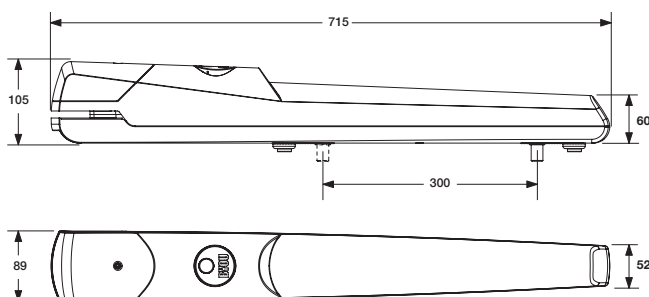

Fig.3



Check, with the leaf completely open, that there is sufficient space for installation (Fig. 4).

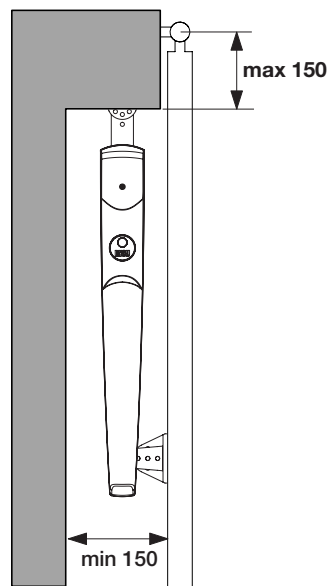
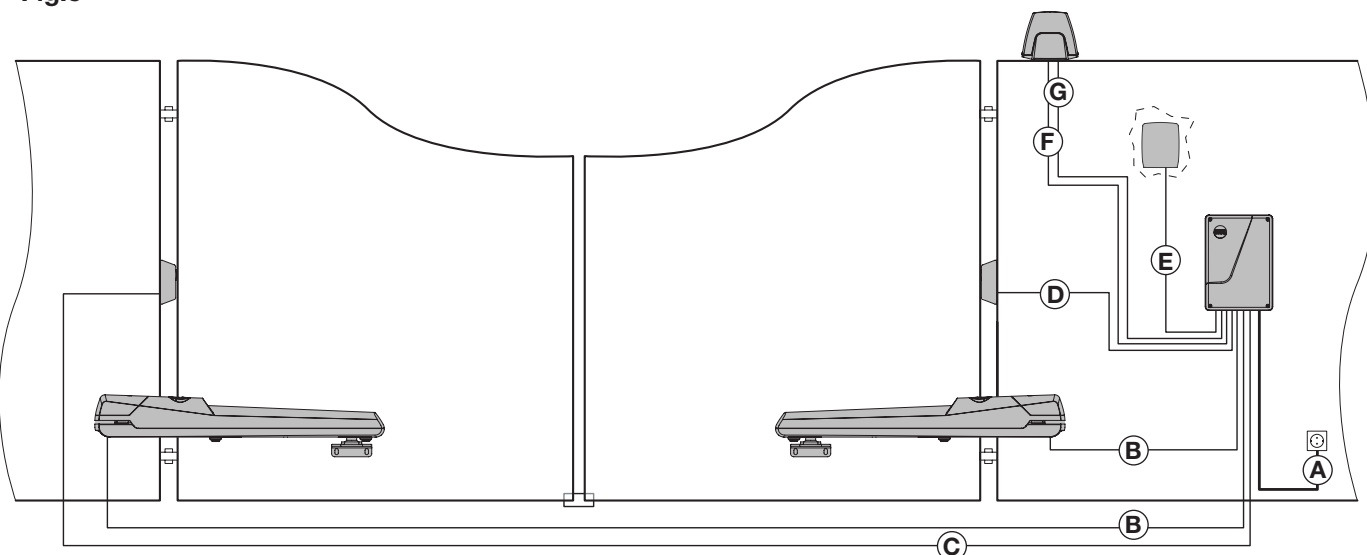

Fig.4

Fig.5



The cables necessary for the installation of BEAUTY can vary according to the accessories installed.



No connection cable is supplied.

Fig. 5 indicates the cables for standard installation.

List of cables

	Connection	Type	Maximum length and notes
A	Mains power supply to the control unit	3x1,5mm ²	30m - [1]
B	Motor connection	2x1,5mm ²	15m - [2]
C	Photocell transmitter connection	2x0,5mm ²	20m - [3]
D	Photocell receiver connection	4x0,5mm ²	20m - [3]
E	Key selector connection for external command	4x0,5mm ²	20m
F	Flashing signal light connection	2x1,0mm ²	10m
G	Connection of the aerial built-in the flashing light	RG 58	[4]

Notes

[1]	 <p>A pre-wired cable with plug is supplied that is to be used exclusively for installation tests and cannot be used for the continuous use of the automation. A qualified BYOU technician will replace it with a network connection that is in compliance with the Standards in force. An omnipolar switch should be provided with the contact opening of at least 3 mm, provided with overload protection and able to cut off the system from the mains. Means for disconnections must be incorporated in the fixed wiring in accordance with the wiring rules.</p>
[2]	It is recommended not to exceed 15 m in length. If it is indispensable to exceed this limit, increase the section of the cable.
[3]	As the receiver photocell (labelled RX) requires more cables with respect to the transmitter photocell (labelled TX), it is more practical to installed the receiver on the wall nearest to the control unit, while the transmitter can be positioned on the wall furthest away.
[4]	There is an aerial pre-installed in the control unit, which in most cases makes this connection superfluous. If reception is disturbed, the capacity of the receiver can be improved by connecting the aerial in the flashing light to the control unit.
	<p>As in layout Fig.5, the connections B and C must be underground: for this purpose prepare a suitable connection raceway that is sufficiently resistant for the type of use.</p> <p>If the other connections are not already set-up, they will be realised in a bricked-up raceway or using raceways from the outside (flexible corrugated sheath) that is in compliance with the Standards in force.</p> <p>If in doubt, contact staff that is specialised in the realisation of these set-ups.</p>
	<p>The cables used must be suitable for the type of connection. For example, for connection protected by raceways use H03VV-F cables, for cables in the outdoor environment always use the H07RN-F type.</p>

Tools and materials

Fig.6

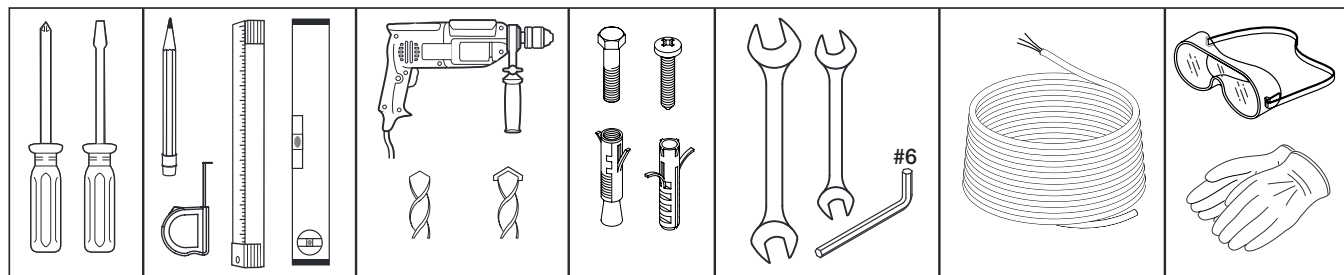

Make sure that there are all tools and materials necessary for installation (fig.6). Also check that they are in compliance with Standards and in perfect working order.

 Use suitable individual protection devices I.P.D. (goggles, gloves, etc)

 The length and type of connection cables depend on the accessories installed (see "Electric connections" paragraph).

The fixing devices for the gear motor are not supplied as they depend on the features of the materials used for the pillars and the leaves.

Choice of installation measurements - 1

Fig. 7 represents a view from above of the automation, indicating the most important measurements for installation.

R indicates the hole in bracket BTY.1 onto which the gear motor is fixed and corresponds to the rotation axes of the gear motor. It is necessary to calculate the correct positioning as indicated below.

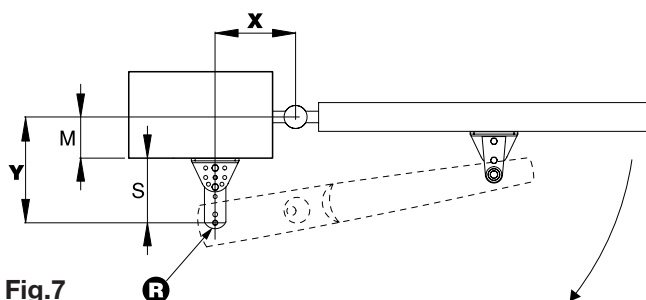



Fig.7

M: is a measurement on the gate and represents the distance between the gate rotation axis and gear motor fixing surface
S: a distance that can be adjusted by means of the supplied bracket BTY.1.

Y: is given by the sum of M+S.

X: depends on the opening angle requested and by the value of the Y measurement.

 **IMPORTANT:** The values of the X and Y measurements must be as similar as possible (max difference 50 mm).

Values that are too different to each other do not allow regular movement of the leaves and could cause malfunctioning.

Detect the value of the measurement M precisely and state it in every box in column M in Table 1.

Calculate all values possible of the Y measurement, adding the value M to the various values of the column S, completing all boxes in column Y of table 1.

S	+	M	=	Y
40 mm	 mm	 mm
97 mm	 mm	 mm
117 mm	 mm	 mm
121 mm	 mm	 mm
135 mm	 mm	 mm
155 mm	 mm	 mm

Establish the opening angle of the leaf:

- Take the leaf into the completely open position.
- If the angle of opening exceeds 90° find the appropriate angle using, if necessary, the goniometer printed on the last page of this manual.

Below find three tables, each referring to one of the opening angles possible, up to 90°, from 90° to 100°, from 100° to 110°.

Up to 90°		from 90° to 100°		from 100° to 110°	
Y	X	Y	X	Y	X
100 mm	150 mm	100 mm	140 mm	100 mm	140 mm
110 mm	150 mm	110 mm	140 mm	110 mm	130 mm
120 mm	150 mm	120 mm	140 mm	120 mm	130 mm
130 mm	140 mm	130 mm	130 mm		
140 mm	140 mm	140 mm	120 mm		
150 mm	130 mm	150 mm	120 mm		
160 mm	120 mm				
170 mm	120 mm				

 recommended measurement

Depending on the values calculated in the Y column of Table 1, select the pairs of measurements Y and X as similar as possible in the table with the requested opening angle.

Make note of the measurement S corresponding to measurement Y thus obtained. This value is indispensable for the correct regulation of the bracket BTY.1, described in the "Fixing the gear motor brackets BTY.1" paragraph.

Choice of installation measurements - 2

As an example, let's suppose that the measurement M detected on the leaf is 35 mm.

The value 35 is inserted in the column M and table 1 is completed, calculating the different values Y:

S	+	M	=	Y
40 mm		35 mm		75 mm
97 mm		35 mm		132 mm
117 mm		35 mm		152 mm
121 mm		35 mm		156 mm
135 mm		35 mm		170 mm
155 mm		35 mm		190 mm

We therefore find the opening angle of the leaf. Let's suppose that the angle detected is 95°, the reference table is that for the angles from 90° to 100°.

Y	X
100 mm	140 mm
110 mm	140 mm
120 mm	140 mm
130 mm	130 mm
140 mm	120 mm
150 mm	120 mm

Among the values recommended in this table, note that the Y:130 measurement is the nearest to the measurement of 132 mm in table 1.

Our installation measurements are:

Y	X	S
130 mm	130 mm	97 mm

Make note of these values for positioning of the brackets BTY.1

Adjustable brackets BTY.1

Using the adjustable brackets BTY.1 it is possible to install the BEAUTY gear reducer with different installation measurements, without having to make cuts and perform welding.

There are two holes in the bracket, both used to fix the gear motor.

Figure 8 shows the main positions with relative measurements, both for hole A and for hole B.

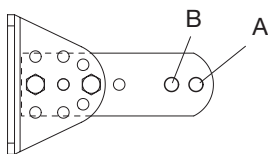

Select the position that corresponds to position "S" calculated in Table 1 of the "Choice of installation measurements" paragraph.

The positions 1 and 2 do not modify the value of the X measurement, the fixing gear motor hole corresponds to the central axis of the bracket.

The positions from 3 to 8 change the value of the X measurement.

With reference to the previously described example, the measurement S of 97 mm requires the position 6.

Note that in this position the measurement X is modified.

It will be necessary to add 72 mm to the measurement X previously calculated in order to have the new bracket-fixing axis.

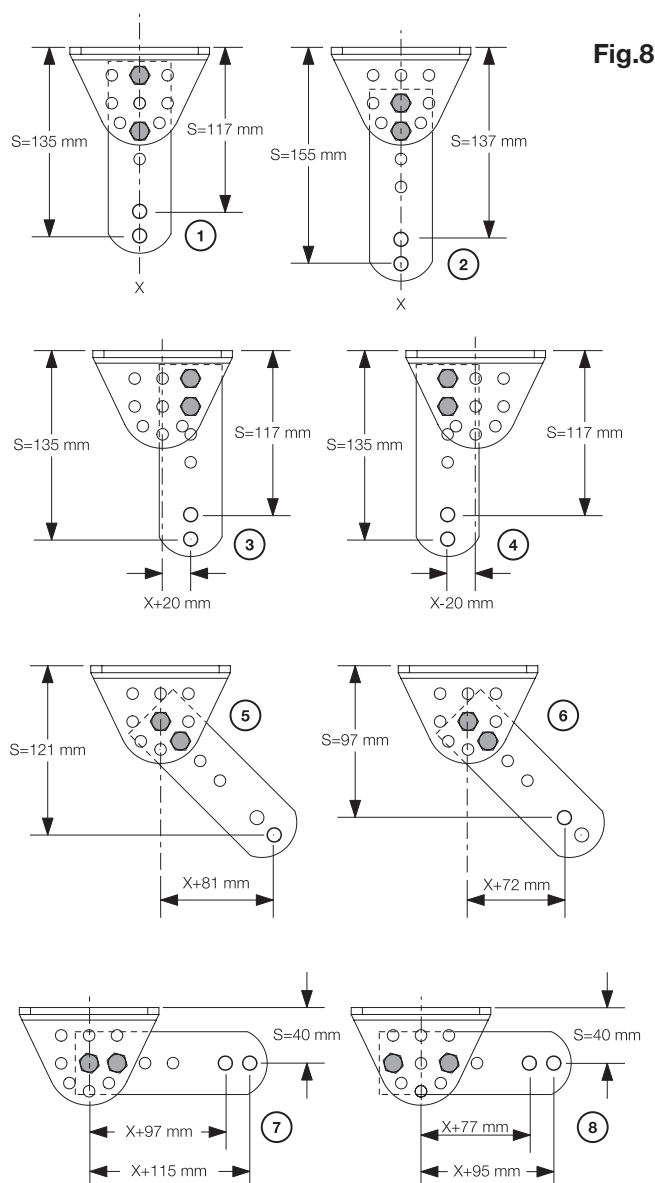

Fixing the gear motor brackets BTY.1

i The screws for wall fixing are not supplied, they are selected on the basis of the features of the materials used for the pillars and leaves.

Assemble the fixing brackets BTY.1 (fig.1-ref.2).
Figure 8 illustrates an example of fixing position 1:

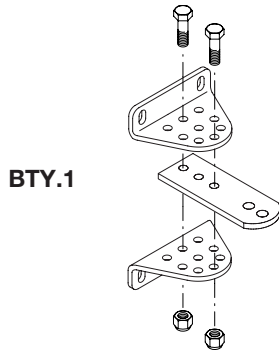

Fig.9

Before fixing the brackets it is important to determine their height from the ground and, consequently, the height of the motor.

1) The measurement H (Fig.10) must be greater than 350 mm. Installation too near to the ground can cause malfunctioning due to humidity, dirt, snow, which infiltrate inside the gear motor.

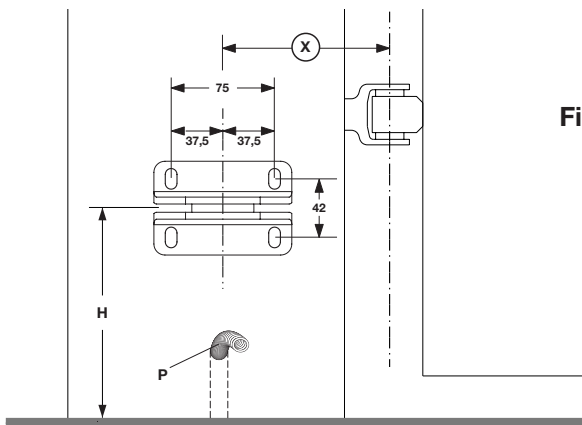
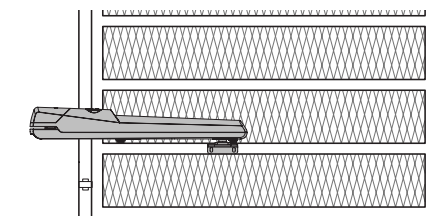

Fig.10

It is important to consider the correspondence between the height established and the presence of gate support structures:



2) The electrical set-up must preferably be under the fixing bracket (fig. 10 - ref.P).

Identify measurement X on the pillar, mark 4 holes for fixing the plate BTY.1 with the measurements indicated in figure 10.

Attention: some positions of the bracket BTY.1 require a correction of the measurement X as indicated in Figure 8

Fix the bracket using the plugs and screws that are suitable for the type of material (fig. 11).

Fig.11

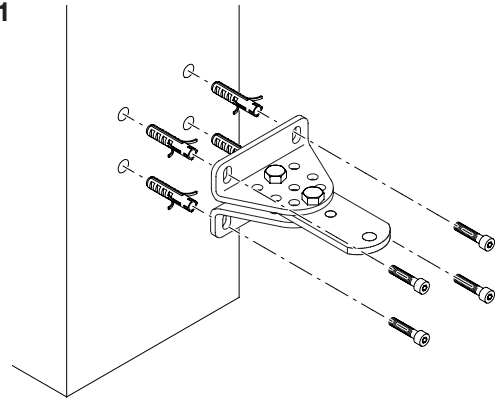

Apply the gear motor to the bracket (fig.12):

- Loosen screw F and then remove the sump C
- Insert the washer R placing it on the bracket
- Insert the gear motor
- Block the gear motor via the screw V and nut D.

Fig.12

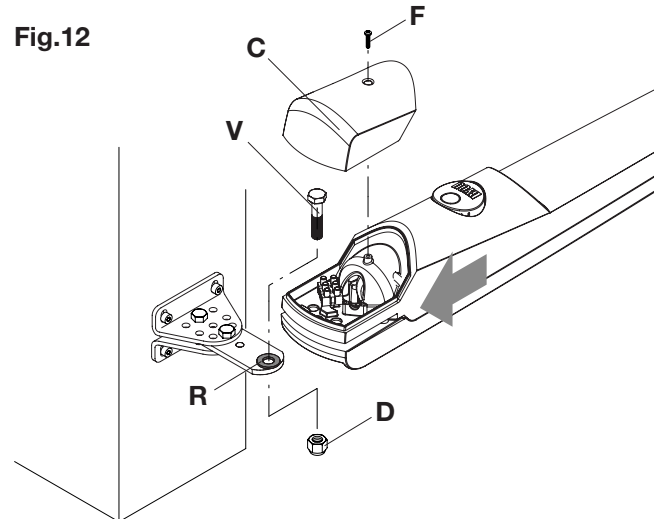

Fixing the gear motor brackets BTY.2



The BEAUTY gear motors supplied with the retracted pin of about 1 cm with respect to the end run stroke (fig. 13).

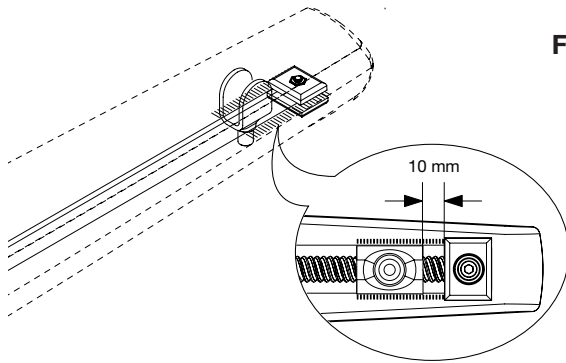

Fig.13

This is the correct position of the pin for fixing the bracket BTY.2 onto the leaf. Proceed as follows:

- Assemble the bracket BTY.2 as indicated in figure 14

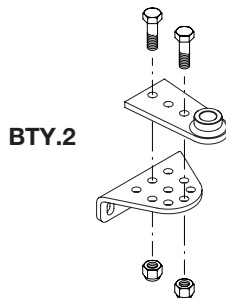

Fig.14

- Apply the bracket BTY.2 to the gear motor pin, blocking it with screw V, positioning the washers R1 and R2 as indicated in figure 15.

The smooth washer R1, must be positioned **above** the grooved washer R2.

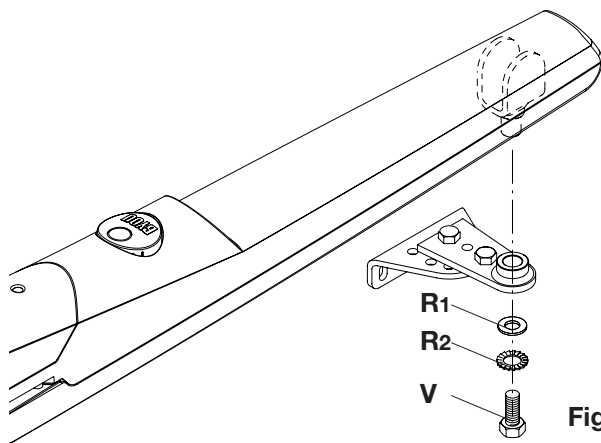

Fig.15

With the leaf in the completely closed position, take the gear motor with the bracket to rest on the leaf (fig.16):

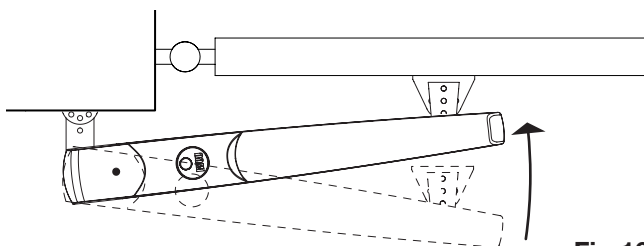
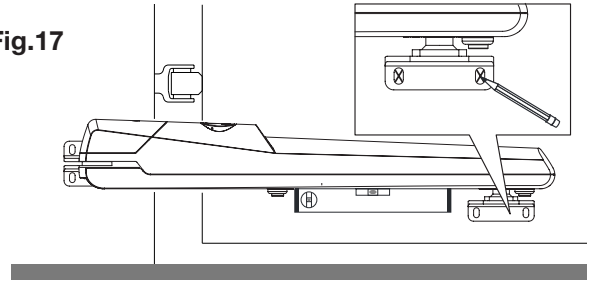

Fig.16

Use a spirit level to check that the gear motor is perfectly horizontal and then mark the two points for drilling the leaf (fig. 17).

Fig.17



Also in this case the fixing devices will be selected on the basis of the material with which the leaf is made. Self-threading screws are used in the example in figure 18.

Fig.18

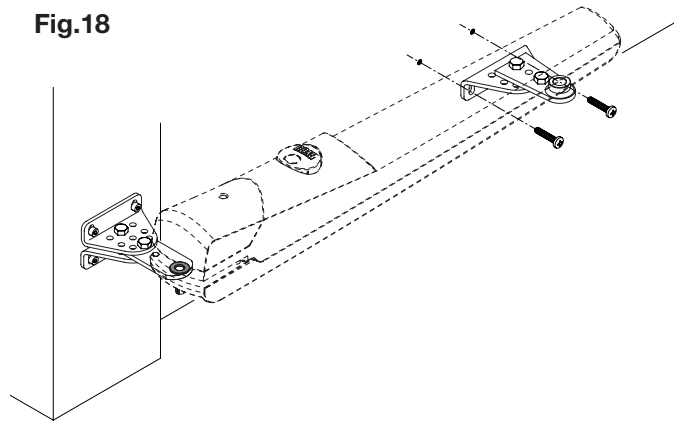

Release the gear motor by turning the circular cover by 180° (fig. 19) and then insert the release key and turn it 90°.

Fig.19

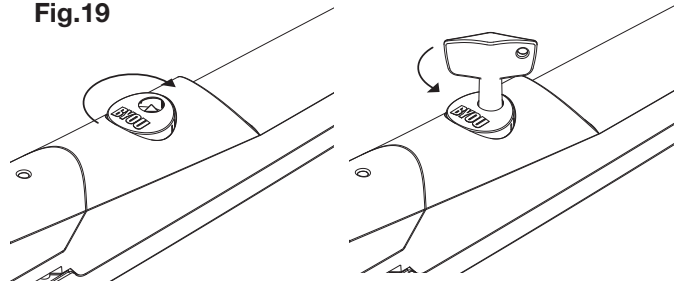

The gear motor is now released and the leaf can be opened and closed manually.

Use several complete manoeuvres to check that the fork slides regularly along the entire run.

Check that during movement the gear motor does not collide with the pillar or the leaf. In this case check the positions of the adjustable brackets. In some cases it may be necessary to mount the bracket BTY.2 in a way to move the gear motor away from the leaf (fig.20).

Fig.20

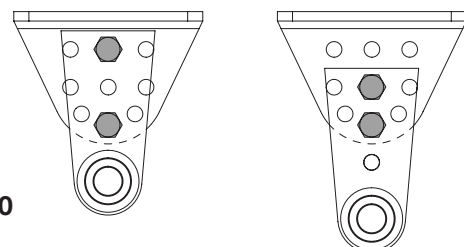

Regulation of opening and closure mechanical stops

There are two adjustable mechanical stops on the bottom of the gear motor, one to stop the opening leaf (fig.20 -ref A), one to stop the closing leaf (fig.20 -ref C).

With the leaf released, take the leaf into the completely closed position.

Use a 6 mm hex wrench to loosen the mechanical stop C and take it to rest at the pin.

Take the leaf to the desired opening position.

Loosen the mechanical stop A and take it to rest at the pin.

Using several manual opening and closure manoeuvres, check that the leaf stop point is correct.

Fig. 20

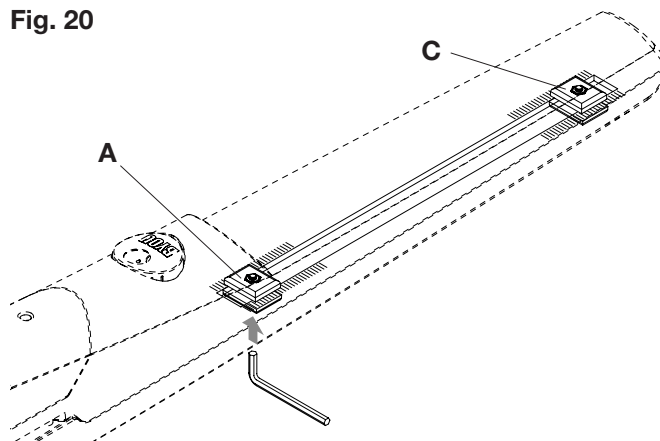

Gear motors wiring

The connection cable to the control unit must have a sufficient curve to follow the movement of the gear motor during the manoeuvre (fig.21 - ref. A).

Loosen the fairlead P, insert the cable through the gear motor and then block the fairlead

Make the connections on the clamp as indicated in Fig.22, respecting the connections indicated in the "Electric connections" paragraph.

Fig. 21

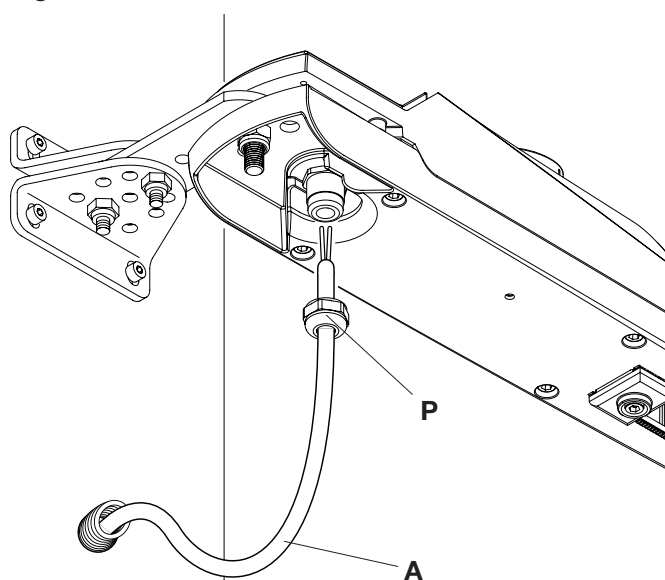
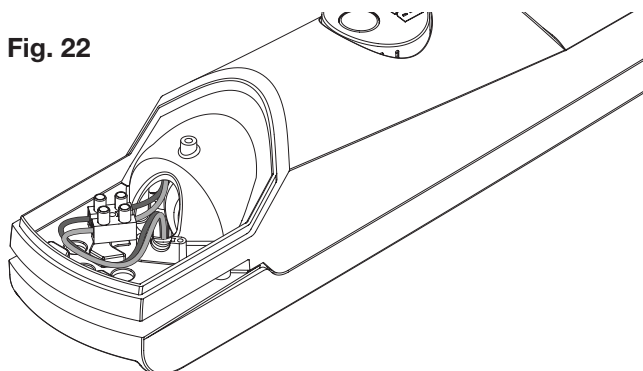

Fig. 22



Fixing the CP.BTY control unit

With reference to the "Electric connections" chapter - Fig.5, select the most suitable position for fixing the control unit, in proximity of the gate in a way to reduce the length of the cables and in a position protected from any accidental blows.

Remove the 4 screws A (fig.23) and then remove cover B

There are 4 set-ups (C) present on the base of the control unit container, which must be broken using a screwdriver.

Place the base on the wall and mark the 4 drilling points.

Make the 4 holes and insert the 4 plugs (E), fix the control unit with the 4 screws D. Plugs and screws are supplied.

There is a seat (F) on the base of the container for the passage of the connection cables. This must be opened using a screwdriver in order to fix a fitting for the corrugated pipe.

The control unit has a pre-wired mains power supply cable that can only be used for installation tests, using an extension for example. A qualified BYOU technician will replace it with a network connection that is in compliance with the Standards in force.

Fig. 23

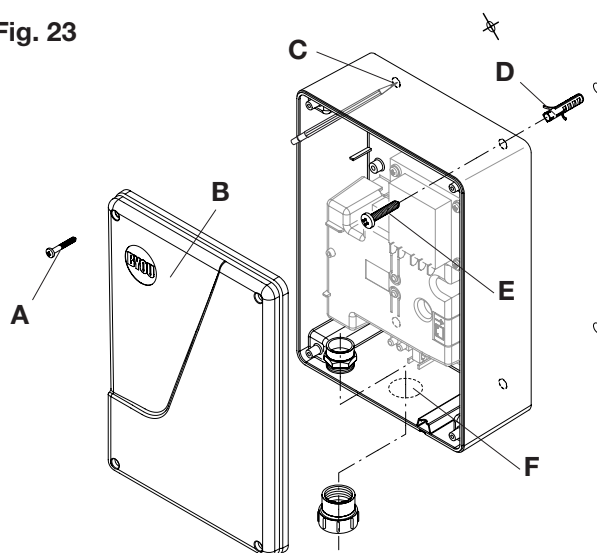

Installation of the flashing light F.BY

Description

Flashing light signalling that the gate is in movement for automatic doors and gates. It has a built-in aerial for the reception of radio transmitters.

Installation

Choose the position of the flashing light so that it is in proximity of the gate and easily visible.

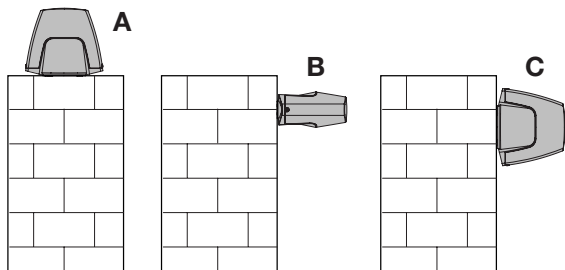

The flashing light can be fixed onto a horizontal or vertical surface. In the case of vertical installation the protection rating is reduced to X4.

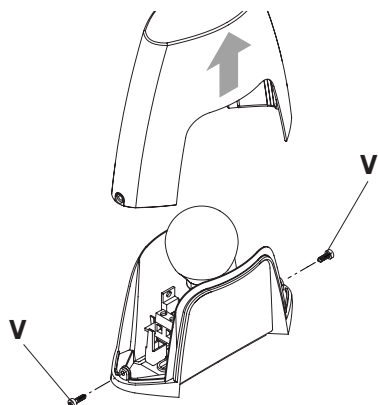

Loosen the two screws V and then remove the transparent cover.

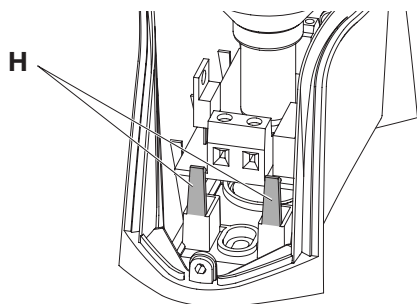

Remove the electronic circuit, pulling the two plastic tabs H outwards, thus releasing the board.

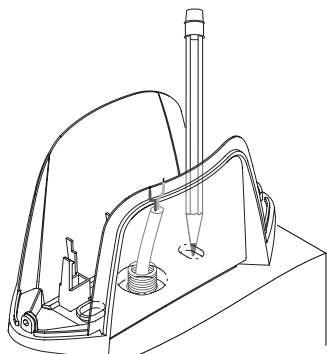

Trace the drilling points using the base as a reference. The central hole must correspond to the passage of the cables.

Two 6 mm plugs and relative screws are supplied for fixing the flashing light.

Make two holes with diameter of 6 mm.

Insert the cable and fix the base using the plugs and screws.

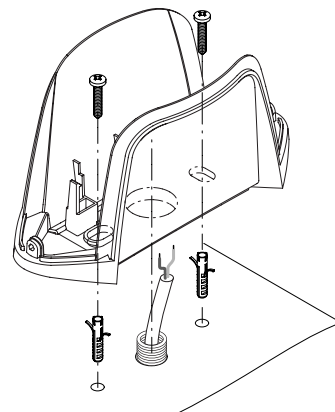

Connections

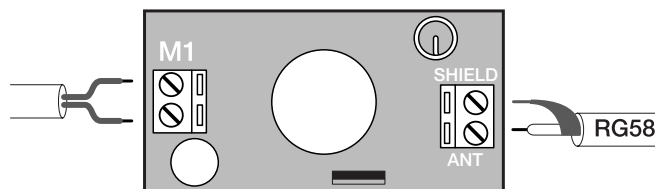

Connect the 24V flashing light output of the control unit to the terminal board M1 (see main connection layout).

Connect the aerial cable RG58 to the terminal board M2 (if requested). The external shield must be connected to the

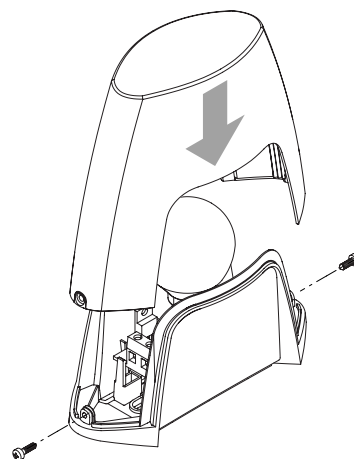

SHIELD clamp. The signal cable must be connected to the ANT clamp.

Put the board back into the relevant seat and then close the flashing light.

TECHNICAL DATA

TECHNICAL DATA	Flashing light F.BY
Power supply	24Vac Flashing light output of the BYOU control units
Bulb	E14/24Vac/dc
Absorption	600 mA
Functioning temperature	-20°C / +70°C
Protection rating	IP44
Dimensions	145x65x128 (mm)

Installation of photocells P.BY

Description

Pair of photocells for detection of obstacles for automations for doors and gates.

The pair is made up of a transmitter (labelled TX) that sends an infrared ray towards the receiver (labelled RX). The receiver has an output with NC contact (normally closed). The interruption of the ray causes the contact to open, the control unit detects the receiver switch-over and interrupts the movement according to the settings selected.

Installation

Open the photocells by using a screwdriver as a lever in the slot

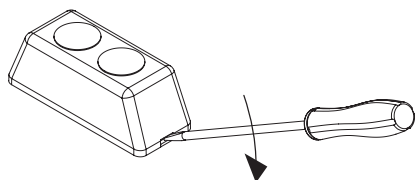

The difference between the receiver and the transmitter is evident from the number of clamps present on the boards:

- 4 clamps for the receiver (RX)
- 2 clamps for the transmitter (TX)

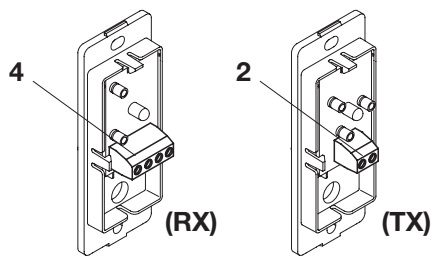

The two photocells must be fixed on the outside and as near as possible to the gate:

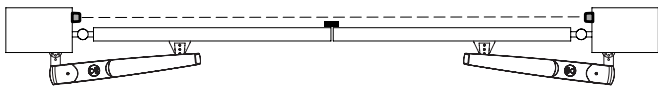

At a height of 40-60 cm from the ground:

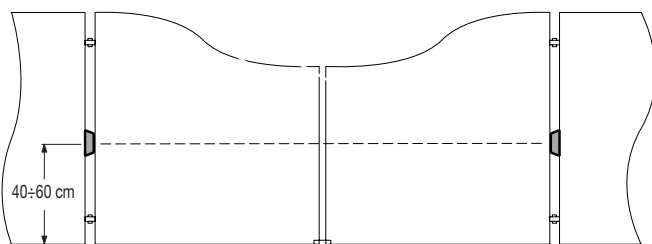

Trace the drilling holes using the photocell base as a reference.

The hole in proximity of the terminal board must correspond to the passage of the cables.

Four 6 mm plugs and relative screws are supplied for fixing the photocells.

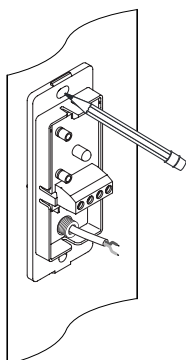

Make two holes with diameter of 6 mm in a way that the hole in proximity of the terminal board corresponds to the set-up of the cables. Insert the cable and fix the base of the photocell to the wall using the plugs and screws.

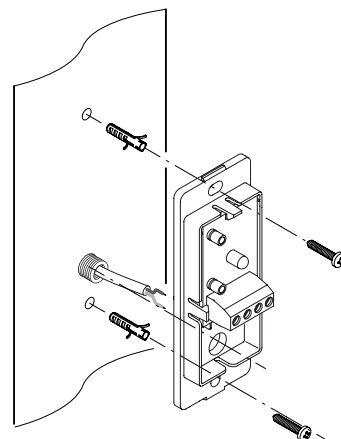

Connections

Connect the TX and RX to the control unit as per the main connection layout.

TX only requires power supply from the 24V output of the control unit, respect the polarities (+/-).

RX requires 24V power supply (respect the polarities +/-) and the connection of the NC contact at the PHOT C input.

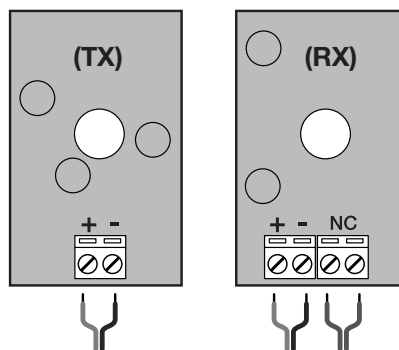

Make the connections and re-position the covers checking that the cover with the lens (RX - 4 clamps) is applied to the receiver. The lens can be recognised by the concentric circles that are visible in transparency.

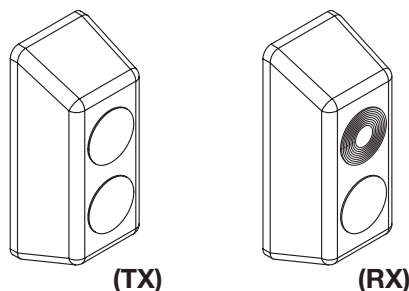

TECHNICAL DATA

TECHNICAL DATA	P.BY photocells
Power supply	24Vac/dc
Capacity (in optimal conditions)	about 20 metres
Absorption	15mA(TX) - 20mA(RX)
Functioning temperature	-20°C / +70°C
Protection rating	IP44
Dimensions	90x35x31 (mm)

Installation of selector K.BY

Description

Key selector with control of automations for automatic gates and doors.

Wall fixing, customised key.

The customised key also has a burglar-resistance function as it is indispensable for opening the selector.

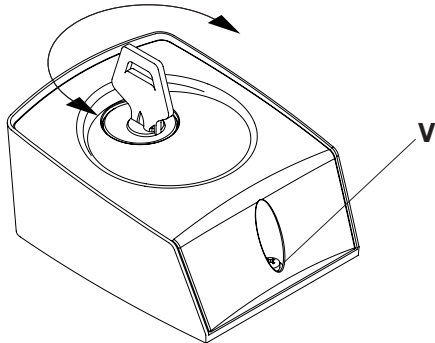

Installation

Select the position of the selector in a way that it is in proximity to the gate, at a height of about 80/100 cm.

To open the selector, remove the screw V, insert the key, turn it in one of the two directions and hold it in this position, lift the selector cover, which separates from the fixed base. Keep the screw V, which is indispensable for closing the selector.

Two 6 mm plugs and relative screws are supplied for fixing the selector base to the wall.

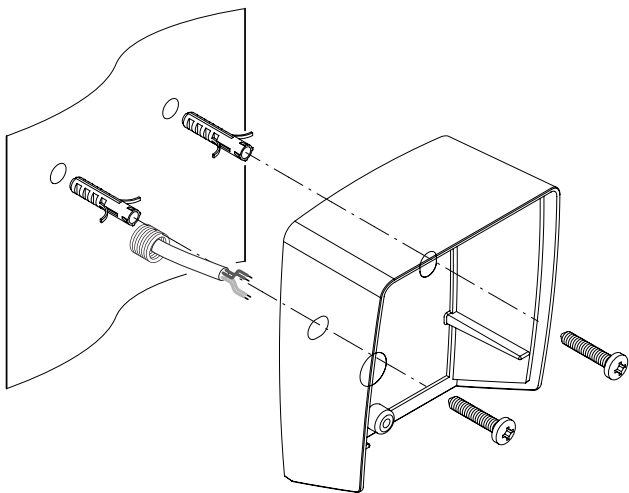

Using the support as a reference, mark and make two holes with diameter of 6 mm in a way that the lower hole corresponds to the set-up of the cables.

Insert the cable and fix the base to the wall using the plugs and screws.

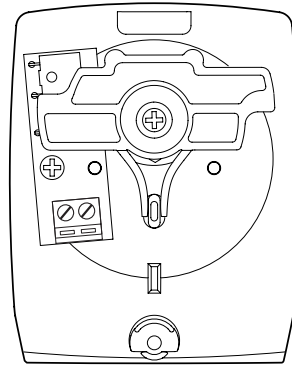

Connections

A terminal board is installed on the selector for the connection to the Step-by-Step input (PP) of the control unit:

No polarity (+/-) has to be respected.

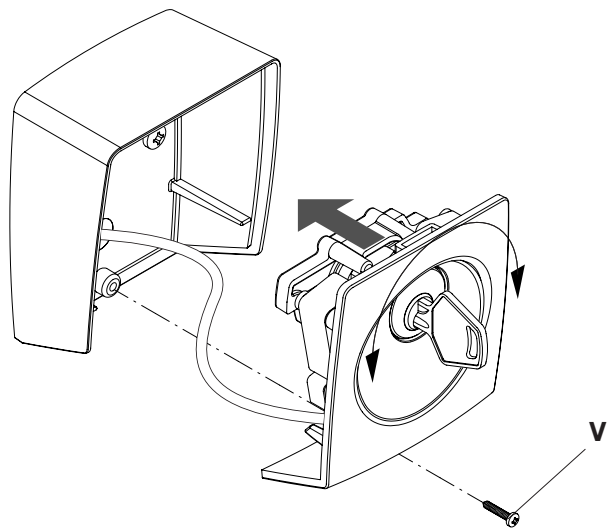

To close the selector, turn the key and hold it in this position, insert the selector into the base fixed to the wall. Release the key and fix the screw V.

TECHNICAL DATA	F.BY selector
Contacts	1 micro switch, with spring for return to central position
Functioning temperature	-20°C / +70°C
Protection rating	IP44
Dimensions	72x90x46 (mm)

Transmitter BY

Description

Radio transmitter for the long distance commands for BYOU automations.

Functioning

The transmitter has three buttons through which it is possible to command the various functions of the automation, configurable in the control unit.

Replacing the battery

When the signal LED starts to flash it means that the battery is starting to go flat and must be replaced.

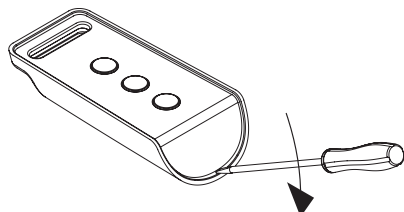

Use a small screwdriver as a lever in the zone indicated, in a way to open the transmitter.

Replace the new battery by inserting it with the positive pole upwards, as indicated in the figure.

IMPORTANT: Do not touch the batteries.
Use rubber gloves.

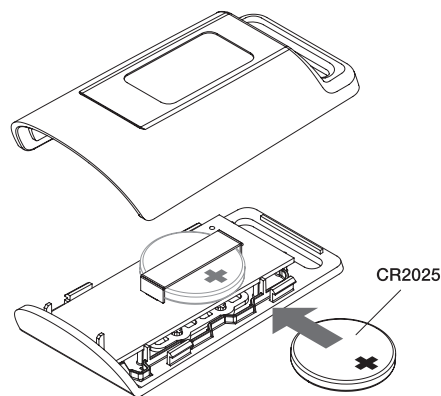

 The batteries contain pollutants, do not throw them in the normal waste but dispose of them as special waste according to the Standards in force.

Close the transmitter.

TECHNICAL DATA	Transmitter BY
Code	Rolling-code
Frequency	433,92 MHz
Functioning temperature	-20°C / +70°C
Dimensions	68x33x16 (mm)

Small columns C.BY

Photocells on small column

The article C.BY is available as an optional accessory, a pair of small columns measuring 50 cm. for the installation of two additional photocells P.BY. They must be positioned inside the property to protect the movement area of the leaves.

Two distinct connections are envisioned in the control unit that are to be used according to the position of the photocell:
PHOT C: The photocell is only active in the closure phase.
PHOT: The photocell is active in opening and closure.

This functioning mode allows the vehicle to enter even if the leaf is not completely open, as long as the manoeuvre area is free from obstacles.

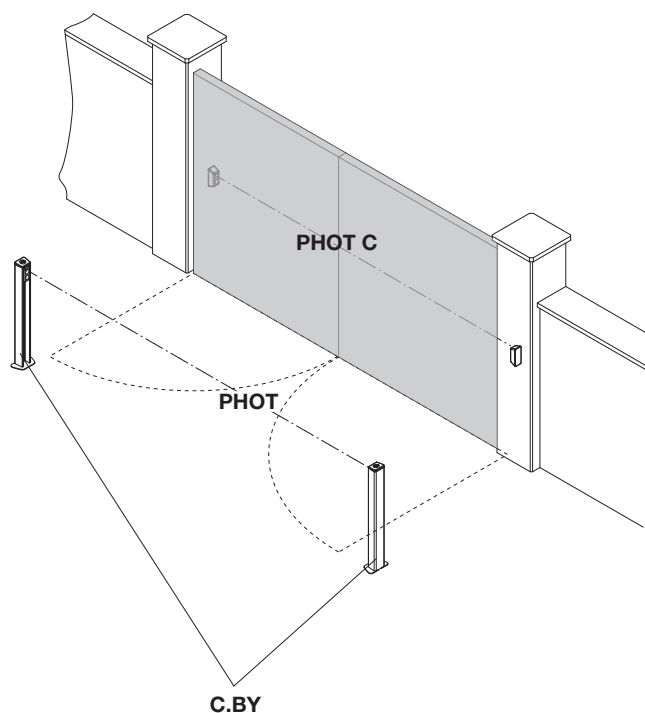

Control unit CP.BTY connections

Except for the mains connection cable, all electric connections have a voltage of 24V and can also be performed by unqualified staff.

KEY:

- 1 Line protection fuse
- 2 Accessories protection fuse
- 3 "PGM" programming button
- 4 Programming button "↑"
- 5 LCD

Connect all accessories making reference to the layout in figure 24 and to the "Electric connections" paragraph, for that con-

cerning the types of cable.

To make connection easier, the accessory clamps have colours that correspond to those of the control unit.



If the leaves have a profile similar to that highlighted in detail P in figure 24, consider that the opening movement always starts with motor 1, while the closure movement always starts with motor 2. The time that passes in between can be regulated using the parameter TDMC (see "Regulation of the phase shift time between the leaves").

DESCRIPTION OF THE TERMINAL BOARDS

CLAMP	COLOUR	DESCRIPTION
PHOT	GREEN	NC contact input from the RX photocell installed on the pillar. The two clamps are connected to each other by a wire (ref. "A"). Remove this wire only if the photocell is connected.
PHOT C	GREEN	NC contact input from the RX photocell installed inside the small column (optional). The two clamps are connected to each other by a wire (ref. "A"). Remove this wire only if the photocell is connected.
STOP	BLACK	STOP input NC contact for auxiliary "STOP" command (optional). The two clamps are connected to each other by a wire (ref. "A"). Remove this wire only if a device is connected to this input.
PP	WHITE	Step-by Step' command input from the key selector. At every impulse sent from the selector a sequence of commands, which can be configured using the PP function, is performed cyclically.
24V	YELLOW	24V output for photocells power supply. Respect the polarities + and - in the connections (ref "B").
BLINK	RED	24 Vdc flashing light connection output
MOT1	ORANGE	Motor 1 connection output respect red and blue (ref. "C")
MOT2	ORANGE	Motor 2 connection output respect red and blue (ref. "C")
SHIELD/ANT	BLUE	Connection of the aerial built-in the flashing light. When connecting the RG58 cable, the external shield must be connected to the SHIELD clamp.

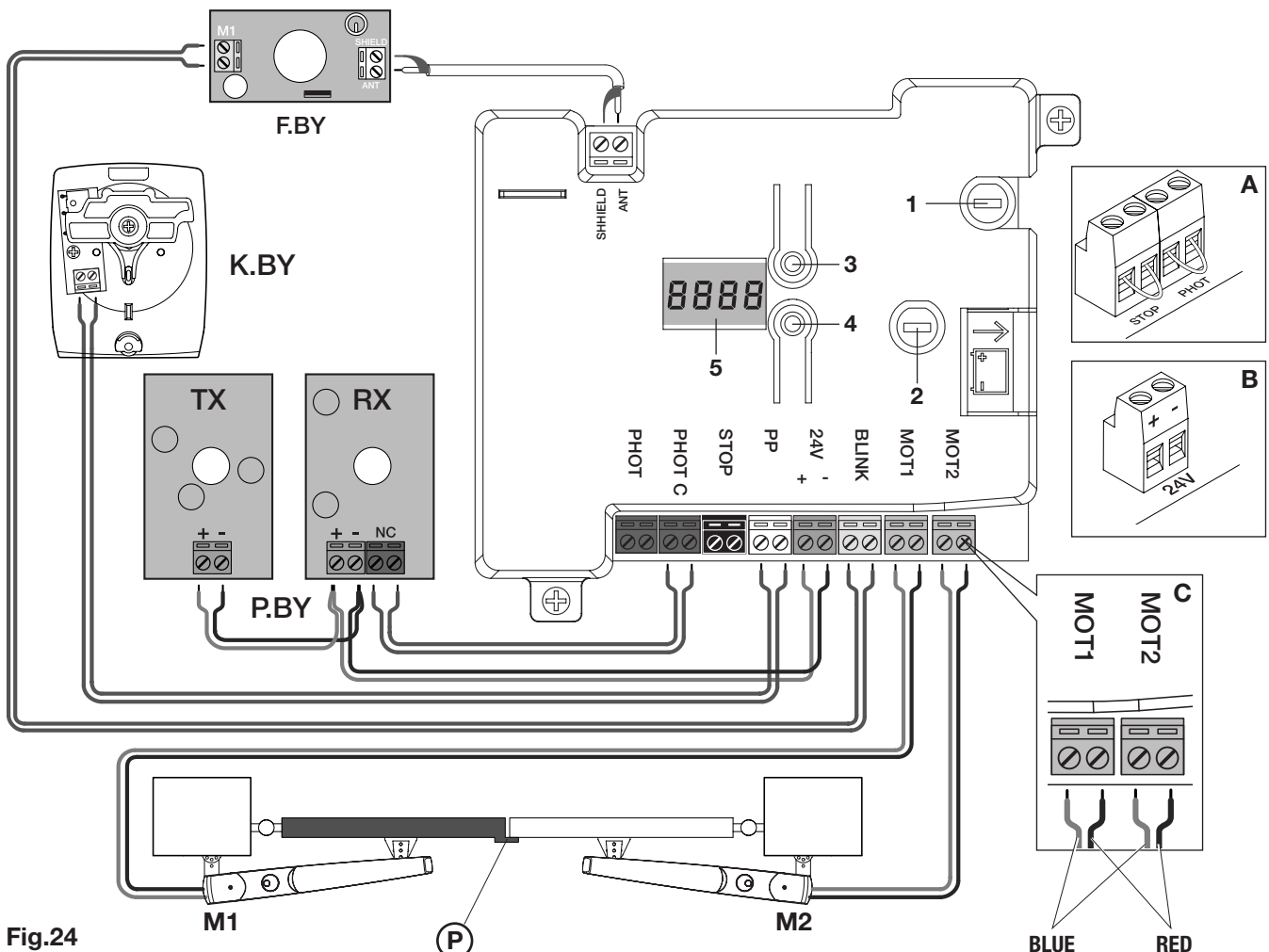

Fig.24

Programming the CP.JMP control unit - Introduction

Programming of the control unit allows the regulation of all parameters indispensable for the correct functioning of the automation.

Programming takes place by means of a series of menus that can be selected from the LCD. A function corresponds to every menu, which will be described successively.

PGM	The "PGM" button allows to enter programming, select the pre-selected menu and confirm the value selected.
↑	The "↑" button allows to scroll the various items in the menu and the values to be set cyclically.
PGM+↑	By pressing "↑" and "PGM" at the same time, return to the upper level of the menu or, if already at the first level, exit programming.

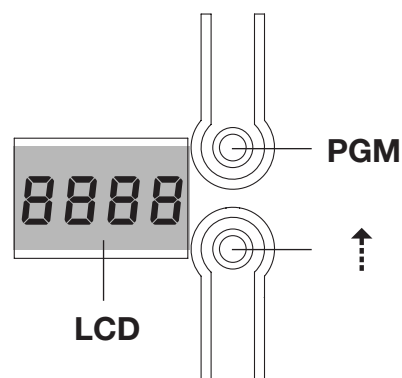

i With the display off, the "↑" button performs a Step-by-Step command. This function can be useful during the programming and inspection phases.

Self-regulation of the functioning parameters (AUTO)

The first and most important function to program is the self-regulation of the parameters, which allows the control unit to automatically set the end run points, the torque applied to the leaf and the slowing phases*.

⚠ During the autosest operations, the control unit automatically performs several opening and closure manoeuvres. Before proceeding, check that no person, animal or obstacle is or can be in the door manoeuvre area.

Proceed as follows:

- 1- Apply mains power supply to the automation via the pre-wired socket, using an extension if necessary.
- 2- Release the leaves, take them manually to about half of the run and block them again.
- 3- Start the autosest phase as described below. As soon as the first manoeuvre starts, carefully check that:
 - a) both leaves must move in the closure direction.
If this is not the case, press "5" and "PGM" at the same time to interrupt the autosest. The display shows the ERR message. Invert the M+/M- wires of the motor/s that moved in the opening direction.
 - b) the first motor to perform closure must be that connected to clamp M2. If this is not the case, invert the connections of motors M1 and M2.

1	Apply mains power supply by connecting the plug	
2	Press the button [PGM] to access programming.	PGM
3	The display shows AUTO, select Auto by pressing the [PGM] button.	AUTO
4	AUTO starts to flash slowly. Press and hold the [PGM] key, after 5 seconds AUTO starts to flash quickly, release the key only when the display shows the PRG message.	
5	The self-regulation phase starts, the display shows PRG. The control unit commands different opening and closing manoeuvres at various speeds. At the end of the manoeuvre the display shows "OK"	PRG
6	To go back to the programming menu, press the [PGM] and [↑] buttons at the same time. To exit programming, remove the power supply or wait for 60 seconds.	PGM+↑

* The slowing phase envisions that the last phase of manoeuvre, both opening and closure, are performed at a slower speed, thus allowing a silent manoeuvre.

The intervention of the photocells or any other command from the transmitter or key selector, interrupts the autosest phase, displaying the message ERR1/2/3. The procedure must therefore be repeated.

Every self-regulation procedure overwrites the previous one.

Perform an autostop procedure after every maintenance intervention or modification of the door.

Regulation of the automatic closure time (TCA)

The automatic closure function allows to set a time, which, on expiry, if the leaf is in the open position the control unit autonomously commands a closure manoeuvre.

With this function active, if you forget to give the closure command or in the case of simultaneous commands, the control unit closes the leaf after the set time.

The factory setting envisions 30 seconds before automatic closure.

1	Press the [PGM] button to access programming or if the control unit is already in the programming menu, press [↑] until the TCA function is displayed.	tca
2	Press the [PGM] button to enter the TCA parameter regulation. The display shows the current value of the TCA parameter. Use the [↑] key to select one of these values: 0 The TCA function is deactivated. 1 The pause time is set at 10 seconds 2 The pause time is set at 30 seconds (default setting) 3 The pause time is set at 60 seconds 4 The pause time is set at 90 seconds	0000 0004
3	Confirm the desired value using the [PGM] key, the display shows PRG.	PrG
4	To go back to the programming menu, press the [PGM] and [↑] buttons at the same time. To exit programming, remove the power supply or wait for 60 seconds.	PGM+↑

Regulation of the motor thrust (PMOT)

The force applied is normally set automatically by the control unit during the self-regulation phase (AUTO).

This menu can be used to modify that set by the control unit, to make up for a friction point for example.

1	Press the [PGM] button to access programming or if the control unit is already in the programming menu, press [↑] until the PMOT function is displayed.	PMot
2	Press the [PGM] button to enter the PMOT regulation. The display shows the current value of the PMOT parameter. Use the [↑] key to select one of these values: 1 low motors torque 2 medium/low motors torque (default setting) 3 medium/high motors torque 4 high motors torque	0001 0004
3	Confirm the desired value using the [PGM] key, the display shows PRG.	PrG
4	To go back to the programming menu, press the [PGM] and [↑] buttons at the same time. To exit programming, remove the power supply or wait for 60 seconds.	PGM+↑

Regulation of the phase shift time when closing (TDMC)

In gates that have a profile (figure 24 - part.A), a phase shift time must be set between movements in order to prevent contact between the leaves.

In the opening phase, the motor connected to clamp M1 always starts 3 seconds before the motor connected to clamp M2. In the closure phase, the motor connected to clamp M2 starts before the motor connected to clamp M1. This phase shifting can be regulated by the parameter TDMC

1	Press the [PGM] button to access programming or if the control unit is already in the programming menu, press [↑] until the TDMC function is displayed.	TDMC
2	Press the [PGM] button to enter the TDMC regulation. The display shows the current value of the TDMC parameter. Use the [↑] key to select one of these values: 0 No phase shifting 1 Phase shifting of 5 seconds (default) 2 Phase shifting of 10 seconds 3 Phase shifting of 15 seconds 4 Phase shifting of 20 seconds	0001 0004
3	Confirm the desired value using the [PGM] key, the display shows PRG.	PrG
4	To go back to the programming menu, press the [PGM] and [↑] buttons at the same time. To exit programming, remove the power supply or wait for 60 seconds.	PGM+↑

Step-by-Step functioning mode (PP)

It is possible to select two different modes of the Step-by Step command sent from the transmitter or the key selector. Every time the button is pressed in the default mode, the following progression of commands is performed cyclically: OPEN>STOP>CLOSE>STOP>OPEN> and so on.

The sequence can be modified by eliminating the intermediate STOP commands: OPEN>CLOSE>OPEN> and so on.

1	Press the [PGM] button to access programming or if the control unit is already in the programming menu, press [5] until the PP function is displayed.	PP
2	Press the [PGM] button to enter the PP regulation. The display shows the current value of the PP parameter. Use the [↑] key to select one of these values: ON OPEN>CLOSE>OPEN functioning OFF OPEN>STOP>CLOSE>STOP>OPEN> functioning (default)	on off
3	Confirm the desired value using the [PGM] key, the display shows PRG.	PrG
4	To go back to the programming menu, press the [PGM] and [↑] buttons at the same time. To exit programming, remove the power supply or wait for 60 seconds.	PGM+↑

Pre-flashing functioning mode (Pre)

An imminent manoeuvre warning mode can be set through the pre-flashing function.

Once activated, the flashing light switches on 3 seconds before the door starts to move.

1	Press the [PGM] button to access programming or if the control unit is already in the programming menu, press [5] until the Pre function is displayed.	PrE
2	Press the [PGM] button to enter the Pre regulation. The display shows the current value of the Pre parameter. Use the [↑] key to select one of these values: ON pre-flashing activated OFF pre-flashing deactivated (default)	on off
3	Confirm the desired value using the [PGM] key, the display shows PRG.	PrG
4	To go back to the programming menu, press the [PGM] and [↑] buttons at the same time. To exit programming, remove the power supply or wait for 60 seconds.	PGM+↑

Condominium function (IBL)

If used in condominiums, it may be preferable that further commands given during the opening phase are ignored. This function can result useful if many users are involved, in a way to prevent several opening commands, given at the same time, causing the movement to stop.

1	Press the [PGM] button to access programming or if the control unit is already in the programming menu, press [↑] until the IBL function is displayed.	IBL
2	Press the [PGM] button to enter the IBL regulation. The display shows the current value of the IBL parameter. Use the [↑] key to select one of these values: ON IBL mode activated OFF IBL mode deactivated (default)	on off
3	Confirm the desired value using the [PGM] key, the display shows PRG.	PrG
4	To go back to the programming menu, press the [PGM] and [↑] buttons at the same time. To exit programming, remove the power supply or wait for 60 seconds.	PGM+↑

Selection of the opening/closure speed (Sld)

If the leaves are particularly heavy, this function can be used to reduce the movement speed.

1	Press the [PGM] button to access programming or if the control unit is already in the programming menu, press [↑] until the Sld function is displayed.	Sld
2	Press the [PGM] button to enter the Sld regulation. The display shows the current value of the Sld parameter. Use the [↑] key to select one of these values: ON reduced speeds OFF standard speed (default)	on off
3	Confirm the desired value using the [PGM] key, the display shows PRG.	PrG
4	To go back to the programming menu, press the [PGM] and [↑] buttons at the same time. To exit programming, remove the power supply or wait for 60 seconds.	PGM+↑

Resetting the control unit (Res)







This function annuls all settings made, taking the control unit back to the initial conditions. It also deletes the settings of the autostart procedure.

NOTE: Any remote controls memorised in the radio receiver are not deleted.

1	Press the [PGM] button to access programming or if the control unit is already in the programming menu, press [↑] until the Res function is displayed.	RES
2	Press and hold [PGM], the RES message starts to flash quickly.	
3	Release the [PGM] button when the PRG message is displayed. The control unit is now taken to factory values.	PrG
4	To go back to the programming menu, press the [PGM] and [↑] buttons at the same time. To exit programming, remove the power supply or wait for 60 seconds.	PGM+↑







Memorising new transmitters (RADI>PP)

To memorise new transmitters with Step-by-Step function for the automation command, proceed as follows:

1	Press the [PGM] button to access programming or if the control unit is already in the programming menu, press [?] until the Radi menu is displayed.	
2	Press the [PGM] button to enter the Radi function. The display shows the first sub-menu PP.	
3	Press the [PGM] button to enter the PP function. The display shows the flashing PUSH message.	
4	Press the BY transmitter button that is to be associated to the Step-by-Step function within 5 seconds.	
5	The display shows OK to confirm memorisation.	
6	To go back to the PP programming menu, press the [PGM] and [?] buttons at the same time. Press the [PGM] and [5] buttons twice at the same time to go back to the main Radi menu. To exit programming, remove the power supply or wait for 60 seconds.	





Memorising pedestrian function (RADI>Ped)

The pedestrian function can be associated to any transmitter button. The pedestrian function envisions the opening of just one leaf connected to clamp M1, proceed as follows:

1	Press the [PGM] button to access programming or if the control unit is already in the programming menu, press [?] until the Radi menu is displayed.	
2	Press the [PGM] button to enter the Radi function. The display shows the first sub-menu PP. Press [?] to display the Ped sub-menu	
3	Press the [PGM] button to enter the Ped function. The display shows the flashing PUSH message.	
4	Press the BY transmitter button that is to be associated to the Pedestrian function within 5 seconds (e.g. if key 1 has already been associated to the Step-by-Step function, key T2 can be associated to the Pedestrian function).	
5	The display shows OK to confirm memorisation.	
6	To go back to the PP programming menu, press the [PGM] and [?] buttons at the same time. Press the [PGM] and [?] buttons twice at the same time to go back to the main Radi menu. To exit programming, remove the power supply or wait for 60 seconds.	



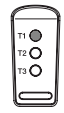

Deleting transmitters (RADI>CLR)

If you have a transmitter that is already memorised, it can be duplicated without accessing the control unit for programming, proceed as follows:

1	Press the [PGM] button to access programming or if the control unit is already in the programming menu, press [↵] until the Radi menu is displayed.	
2	Press the [PGM] button to enter the Radi function. The display shows the first sub-menu PP. Press [↵] twice to display the CLR sub-menu	
3	Press the [PGM] button to enter the CLR function. The display shows the flashing PUSH.	
4	Press any transmitter button BY that is to be deleted within 10 s.	
5	The display shows OK to confirm cancellation.	
6	To go back to the PP programming menu, press the [PGM] and [↵] buttons at the same time. Press the [PGM] and [↵] buttons twice at the same time to go back to the main Radi menu. To exit programming, remove the power supply or wait for 60 seconds.	

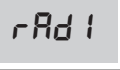

Complete deletion of the receiver memory (RADI>RTR)

To delete the memory completely, eliminating all previously-inserted remote controls, proceed as follows:

1	Press the [PGM] button to access programming or if the control unit is already in the programming menu, press [↵] until the Radi menu is displayed.	
2	Press the [PGM] button to enter the Radi function. The display shows the first sub-menu PP. Press [↵] three times to display the RTR sub-menu	
3	Press the [PGM] button to enter the RTR function. Press and hold [PGM], the RTR message starts to flash quickly.	
4	When the RTR message switches off, release the [PGM] button, the display shows the PRG message. All remote controls are now deleted from the memory.	
6	To go back to the PP programming menu, press the [PGM] and [↵] buttons at the same time. Press the [PGM] and [↵] buttons twice at the same time to go back to the main Radi menu. To exit programming, remove the power supply or wait for 60 seconds.	

Remote controls quick duplication

If you have a transmitter that is already memorised, it can be duplicated without accessing the control unit for programming, proceed as follows:

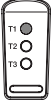
1	With remote control that is already memorised, give an opening command and wait for the leaf to be in the completely open position.	
2	Press all three transmitter keys, already memorised, at the same time until the flashing light switches on.	 TX1
3	Press the button of the remote control that is already memorised that is to be copied into the new transmitter. The flashing light switches off for 5 seconds.	 TX1
4	When the flashing light switches back on, press the button of the new transmitter that is to assume the function of the button selected in point 3.	 TX2
5	If a new transmitter is to be duplicated, repeat the procedure from point 2. Wait 60 seconds to exit the programming procedure.	



ALL OPERATIONS DESCRIBED IN THIS PARAGRAPH ARE EXCLUSIVE COMPETENCE OF AUTHORISED BYOU STAFF, IN COMPLIANCE WITH THAT ENVISIONED IN THIS MANUAL AND THE STANDARDS IN FORCE.

The respect for the indications given below is indispensable to guarantee the maximum safety of the automation.

The BYOU authorised technician must perform all tests envisioned by the Law, Standards and Regulations in force depending on the risks present, particularly respecting all requisites of the EN 12445 Standard, which establishes the test methods for gate automations.

INSPECTION

1 Check that the model selected is suitable for the type of application and that all automation components have been installed correctly, with respect to the indications in this manual.

2 Test opening and closure and control that the movement of the leaf is regular without friction points.

3 Check that all electric connections are made correctly and with cables that are in compliance with the Standards.

4 Check the correct functioning of photocells, transmitters, key selectors, manual release devices.

5 For the photocells, check that on the passage of a cylinder with diameter of 5 cm and length of 30 cm the switch-over takes place on the optical axis with the consequent movement stop. The photocells must intervene when passing the cylinder in proximity of the TX, in proximity of the RX and in the centre.

6 Take the measurement of the force of impact according to that indicated by the EN 12445 Standard, intervening, if necessary on the "Regulation of the motor thrust (PMOT) paragraph.

7 Replace the temporary power supply cable with a mains connection that is in compliance with the Standards in force and the type of installation.

COMMISSIONING

Commissioning of the automation can only be performed if all of the previously-described inspection phases have had a positive result.

1 Apply the warning plate, supplied with the automation, to the gate in a well-visible position.

2 Apply a plate to the gate that contains the following data: Type of automation, name and address of the person in charge of commissioning (manufacturer), serial number, year of manufacture and CE mark.

3 Realise the technical file as per indications of the EN 12445 Standard, attaching the entire drawing (e.g. figure 2, electric wiring diagrams (e.g. figure 5), risk analysis and solutions adopted, declaration of conformity of the manufacturer of the devices used (included in this manual).

4 Fill in and supply the owner of the automation with the declaration of conformity.

5 Realise and supply the owner with the "user guide" for the automation, also using the user guide present in this manual.

6 Realise and supply the owner of the automation with the periodical maintenance plan.

7 Do not start the automation before having informed the owner completely regarding the dangers and risks deriving from incorrect use of the automation.

Safety devices

IMPORTANT!READ CAREFULLY!

In order to comply with regulations **EN 12445** the installation of resistive edges is compulsory.

It will be duty of the technician responsible for the installation making a risk analysis and decide where and when install the resistive edge.

BYOU can provide all the devices necessary for your installation and relative accessories, contact your trusted supplier for any further information.

On the picture below an example of application on the primary closing edges.

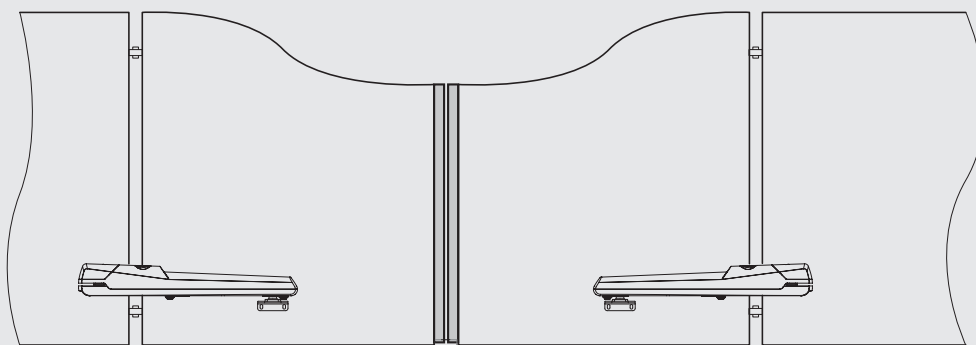

What to do if...

Below find the most common functioning problems and the relative solutions. :

Problem	Cause	Solution
The automation does not work	There is no mains power supply ----- The control unit is not connected ----- The photocells are engaged ----- One or more protection fuses have intervened	Check for the presence of mains power supply ----- Check all connections to the control unit ----- Check that there is no obstacle between the photocells ----- Check the integrity of the fuses and replace them if necessary.
The automation does not work using the remote control.	The remote control battery is flat, the remote control LED flashes quickly ----- the remote control has not been memorised	Replace the remote control batteries ----- Memorise the remote control.
The automation does not work using the key selector	The selector is not connected correctly or is faulty.	Check the key selector connections or replace them if faulty
The gate stops in the opening or closure phase, inverts the movement for a few seconds and then stops.	The obstacle detection sensor has intervened	If no obstacles are present, release the motor and check for the presence of friction points. Perform a new self-learning. Increase the value of the PMOT parameter
The door does not close	STOP input active. ----- Obstacle between the photocells or photocells broken	Check the connections of the STOP input ----- Remove the obstacle or check the photocells
The flashing light does not switch on	The bulb has blown ----- The flashing light is not connected correctly	Replace the bulb ----- Check the connections.

The control unit LCD displays several messages during normal functioning and in the case of breakdown:

Message	Description
<i>Err</i>	Stop the autoset phase by pressing the [PGM] and [5] buttons at the same time,
<i>Err 1</i>	Motor error. Check the motor connections or broken motor
<i>Err 2</i>	Photocell error. Check the photocell connections or broken photocells.
<i>Err 3</i>	PP input activation error during the autoset phase
<i>Err 4</i>	STOP input activation error during the autoset phase
<i>StoP</i>	STOP input active
<i>PhTo</i>	"PHOT" photocell input active
<i>PhTc</i>	"PHOT C" photocell input active
<i>oPEn</i>	Start of opening manoeuvre
<i>cLoSE</i>	Start of closure manoeuvre
<i>ALt</i>	Stop the manoeuvre by means of the PP command.
<i>bALt</i>	The automation is functioning with the buffer battery in the absence of mains power supply (only with CB.BY accessory installed).

KEEP THIS GUIDE AND MAKE IT AVAILABLE TO ALL USERS OF THE AUTOMATION

SAFETY STANDARDS

Do not stand in the movement area of the door.
Do not allow children to play with the commands or in proximity of the leaves.



In the case of functioning anomalies do not attempt to repair the fault but contact a BYOU specialised technician.

MAINTENANCE

- Periodically check the efficiency of the manual emergency release.
- The actuator does not require routine maintenance, however it is necessary to periodically check the safety devices and the other parts of the plant that could create dangers following wear.

DISPOSAL

Whenever the product is put out of service, the legislative provisions in force must be followed regarding differentiated disposal and re-cycling of the various components (metals, plastics, electric cables, etc.). It is advised to contact a BYOU specialised technician or a specialised company that is enabled for this purpose.

MANUAL MOVEMENT FROM INSIDE

In the case of functioning anomalies or power cuts, the automation can be released and the door moved manually, proceed as follows:

- 1) Turn the circular cover by 180°, in a way to view the triangular pin.

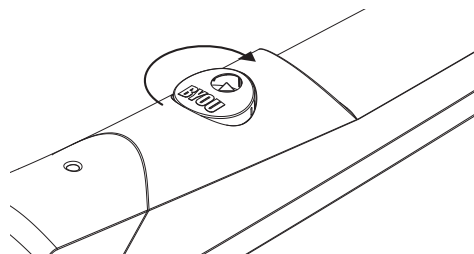

- 2) Insert the BTY.3 release key and turn by 90°
The door is no longer restricted by the automation and can be opened and closed manually.

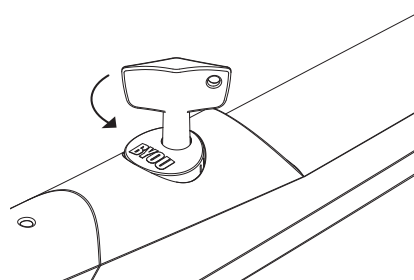

To go back to automatic functioning mode, put the release key back in the initial position, remove it and put the circular cover back in its initial position.

CE declaration of conformity for machines
(Directive 89/392 CE, Attachment II, part B) - Do not put into service

The undersigned Luigi Benincà in quality of the legal representative, declares that the product:

Manufacturer: AUTOMATISMI BENINCA' SpA
Address: Via Capitello 45 36066 Sandrigo (Vicenza) - ITALIA
Description Electromechanical automation with control unit
for swinging gates
Model: BEAUTY
Accessories: CP.BTY, BY, F.BY, P.BY, K.BY

conforms with the requirements of the following EU Directives:

- DIRECTIVE 2004/108/CE OF THE EUROPEAN PARLIAMENT AND COUNCIL, 15 December 2004, in relation to the harmonisation of the legislation of member states regarding electromagnetic compatibility , in abrogation of Directive 89/336/CEE, per the following harmonised standards:
EN 61000-6-2:2005, EN 61000-6-3:2007.
- DIRECTIVE 2006/95/CE OF THE EUROPEAN PARLIAMENT AND COUNCIL, 12 December 2006, in relation to the harmonisation of the legislation of member states regarding electrical material intended to be used within certain voltage ranges, per the following harmonised standards:
EN 60335-1:2002 + A1:2004 + A11:2004 + A12:2006 + A2:2006 + A13:2008; EN 60335-2-103:2003.
- DIRECTIVE 2006/42/CE OF THE EUROPEAN PARLIAMENT AND COUNCIL, 17 May 2006, in relation to machinery, amending Directive 95/16/CE, in relation to the requisites for "partly completed machineries", per the following harmonised standard:
EN13241-1:2003.
- Automatismi Benincà SpA declares, furthermore, that the pertinent technical documentation has been completed in conformity with Annex VII B of Directive 2006/42/CE and that the following essential requisites have been satisfied: 1.1.1 - 1.1.2 - 1.1.3 - 1.1.5 - 1.2.1 - 1.2.3 - 1.2.6 - 1.3.1 - 1.3.2 - 1.3.3 - 1.3.4 - 1.3.7 - 1.3.9 - 1.5.1 - 1.5.2 - 1.5.4 - 1.5.5 - 1.5.6 - 1.5.7 - 1.5.8 - 1.5.10 - 1.5.11 - 1.5.13 - 1.6.1 - 1.6.2 - 1.6.4 - 1.7.2 - 1.7.4 - 1.7.4.1 - 1.7.4.2 - 1.7.4.3.
- The manufacturer agrees to forward the pertinent information regarding the "partly completed machinery" to the national authorities if justifiably requested to do so. This agreement includes the means of transmission and does not affect the manufacturer's intellectual property rights.
- The "partly completed machinery" may not be put into service unless the machine into which it is to be incorporated has been declared conforming - as applicable - to the requirements of Directive 2006/42/CE.
- Furthermore, the product, with limitation to the applicable parts, is conforming with the following standards:
EN 12445:2002, EN 12453:2002, EN 12978:2003.

Sandrigo, 10/04/2015

Luigi Benincà, Legal representative.

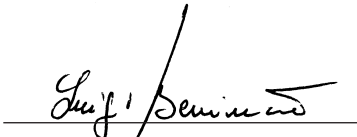

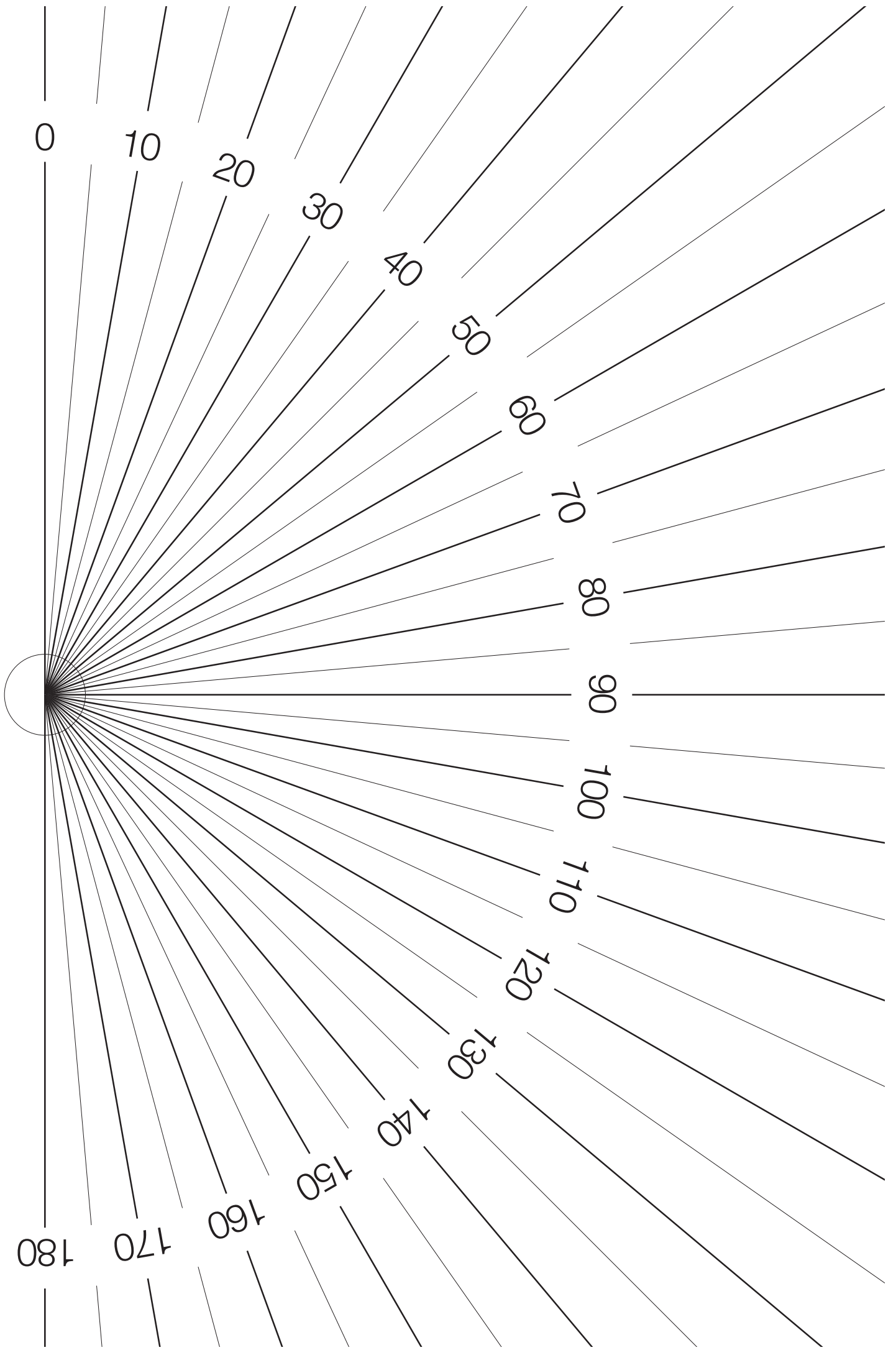

SAVE YOUR ENERGY
BYOU®

BYOU è un marchio di Automatismi Benincà SpA

via Capitello, 45 • 36066 Sandrigo (VI) ITALY • Tel +39 0444 1510294 • Fax +39 0444 759728 • info@byouweb.com • www.byouweb.com