

AGG DOORS Pty Ltd

FOR SERVICE AND INSTALLATION

Ph: 9799 1999

www.aggdoors.com.au

MODEL BOL4

**Residential Garage Door Opener
for Sectional and One Piece Track Garage Doors
up to 2.4M HIGH**

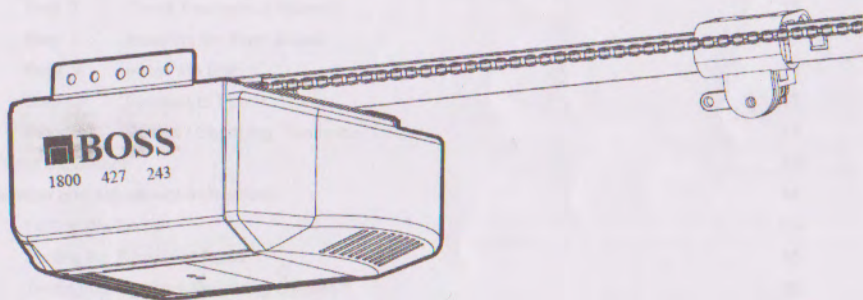

Installation Instructions and Owner's Manual

READ THIS MANUAL CAREFULLY BEFORE BEGINNING INSTALLATION
This Operator Must be Installed by a Qualified Installer Only

Contents

Safety Instructions	03
Before Starting	03
Pre-Assembly Check	03
Product Features/ Specifications	04
Door Test	05
Tools Required	05
Component Identification & Inventory	06
Fastener Identification	06
Assembly Instructions	07
Installation Notes	08
Step 1 Mounting the Front Bracket	08
Step 2 Attach the Rail Assembly to Front Bracket	09
Step 3 Position the Power Head for Mounting Bracket	09
Step 4 Mounting the Power Head to Ceiling	09
Step 5 Recheck all Fasteners for Tightness	09
Step 6 Door Arm, Bracket and Plate Installation	10
Step 7 Check Emergency Release	10
Step 8 Installing the Push Button	11
Step 9 Install the Bulb	11
Step 10 Connect to Power	11
Step 11 Setting / Changing Transmitter Codes	11
Tilt Door Installation	12
Operation and Adjustment Instructions	14
Setting the Limits	14
Setting the Sensitivity Force	15
Testing the Openers Reversing System	16
Testing the Photo eye system	16
Final installation	17
Trouble Shooting	18
After the Installation	19
Parts Breakdown	20
Warranty	22

NOTICE

BOSS Garage Door Openers are designed and tested to offer safe operation, provided installation and use of this product is followed in strict accordance with these instructions for assembly and installation. Failure to comply with these instructions could cause property and/or bodily injury. The opener is intended only for the use described in this manual and use other than intended will void any and all warranties herein described.

Read and Follow These Important Safety Instructions

You will see **Warning** and **Caution** statements on the following Pages.
Read and follow these safety instructions carefully. Failure to do so could result in serious personal injury or death.



Warning means that severe injury or death may result from failure to follow instructions

Caution means that property damage or injury may result from failure to follow instructions

- Be sure to read and follow all instructions carefully.
- Locate lighted push button within sight of garage door, away from all moving parts and out of reach of children (minimum 1.5M above floor). To reduce the risk of injury to persons, to use this operator only with a sectional door.
- Check to make sure the garage door is properly installed and balanced. Because of the extreme tension most garage door parts are under extreme tension. Do not attempt to adjust on your own. Have a qualified garage door service person make repairs to cables, spring and other hardware before installing the opener.
- Mount the Emergency Release Knob 2M from the floor. Use the manual release Only to disengage the trolley. Do not use the Red Release Cord and Knob to pull door up or down. If possible, use the Emergency Release only when the door is closed.
- After installing opener, the door must reverse when it comes in contact with a 40mm high object. Check this safety feature often.
- Disengage all existing garage door locks to avoid damage to the garage door.
- Aluminum and Steel Doors must be Reinforced to Prevent Damage. Consult with Manufacturer for Recommendations.
- All installation and wiring must be done in strict compliance with local and state building and electrical codes. Connect the power cord to a properly grounded outlet only. Do not in any way alter or remove the grounding pin.
- Never operate the opener if the system is not operating properly.
- Always disconnect electric power before making repairs or removing cover.
- Activate opener only when the door is in full view and free from obstructions.
- No one should enter or leave the garage while the door is moving. Do not allow children to play near, or operate the door. Keep the remote control away from children.
- After Installation is complete fasten this manual near the garage door. Perform periodic safety checks and recommended maintenance and adjustments.

Product Features

1. **Motor:** Permanently Lubricated, thermally protected, heavy duty motor with Automatic reset.
2. **Opener Lights:** Turn on and off automatically with 2-1/2 minutes illumination for your safety and convenience.
3. **Sensing System:** A built-in sensing system detects obstructions during door operation. If in the Downward (close) travel mode, the Opener will sense an obstruction and reverse to the full open position. In the Open mode, the Opener will stop. In both cases the light will start flashing and continue to flash for 60 seconds. Since all doors are different, the Sensing System has independent adjustments for customizing the level of force for the normal opening and closing of specific door.
4. **Close Limit Switch:** In winter months it's common for small pieces of ice or packed snow to be trapped under the door. Ground swelling may also effect the close limit setting of the Opener. The Close Limit Switch overrides the Sensing System under the last one (1) inch of closing travel and prevents the door from reversing if it encounters an obstruction at this point.
5. **Emergency Release:** A pull cord allows manual disconnect and operation of door during power failure. Unit will automatically reconnect when release is reset (the trolley release lever is snapped back to its original position), power is restored and Opener is activated.
6. **Mechanical Door Lock:** When properly adjusted, opener locks door in closed position preventing unwanted entry.
7. **Easy Connect Continuous Monitor Entrapment System:** System allows quick and easy installation of "Silent Guard" Photo eye system (Optional) while control circuitry monitors these devices continuously for proper operation.
8. **Constant Contact to Close:** For utmost safety if "Silent Guard" Photo eye system (Optional) fails constant contact of mechanical push button is necessary to close door. In this mode of operation, a radio transmitter cannot be used to close door.
9. **Momentary Contact to Close:** Single touch to Radio Transmitter or Wall Button will allow door to close as long as Silent Guard Photo eye system (Optional) is operational.
10. **Silent Guard Photo eye system (Optional):** An invisible infra-red beam of light guards the door opening and reverses a downward moving door if the beam is broken by a stationary or moving object. If the beam is broken, the opener light will flash for 30 seconds. Motor control circuitry constantly monitors the Silent Guard Photo eye system for proper operation.
11. **Digital Radio Control:** Built in allowing over 1.6 million private codes, easily selected without use of tools. Bright transmitter LED indicates operation and monitors battery condition.

Door Test

Before beginning installation of the operator please complete the following test to insure that your door is balanced and in good working condition. A poorly balanced door could cause severe personal injury and damage to the opener. Always have a qualified garage door service person make any needed adjustments and/or repairs to your door before proceeding with installation.

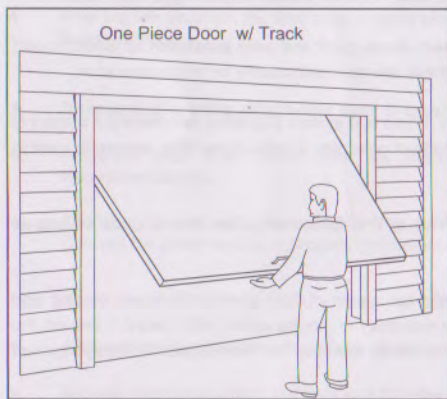
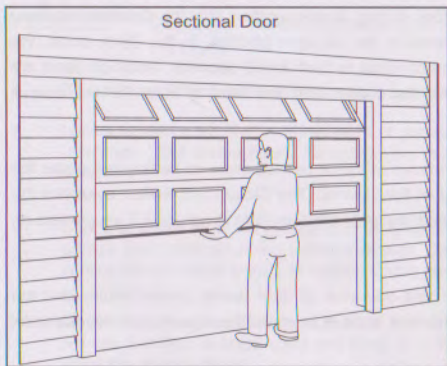

1. Raise and lower the door and check closely for areas of sticking and binding. Check for loose hinges, wobbly rollers, frayed cables and damaged or broken springs. Contact a qualified garage door service person to make the necessary adjustments.
2. Lift the door approximately halfway. When released, the door should stay in that position. If door pulls open or moves downward, the spring mechanism is not adjusted properly. Contact a qualified garage door service person to make the necessary adjustments.
3. When properly installed and adjusted the door will remain clear of the opening, when allowed to rest at its natural full open position. If door drifts up or down the door is not adjusted properly. Contact a qualified garage door service person to make the necessary adjustments.



Do Not Install the Opener Until These Adjustments and Repairs Have Been Made.

Carefully follow the instructions for the assembly and installation of the garage door opener contained in this manual

Tools Required for Assembly and Installation

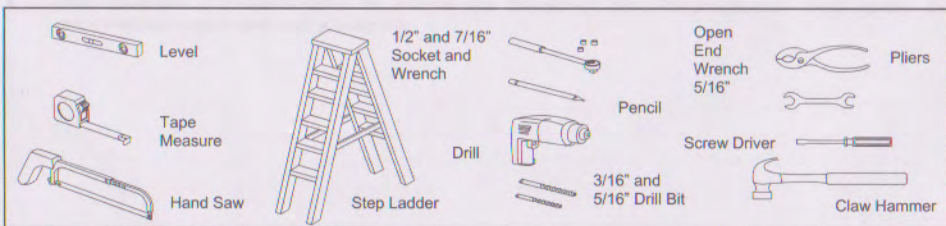

Components Identification and Inventory

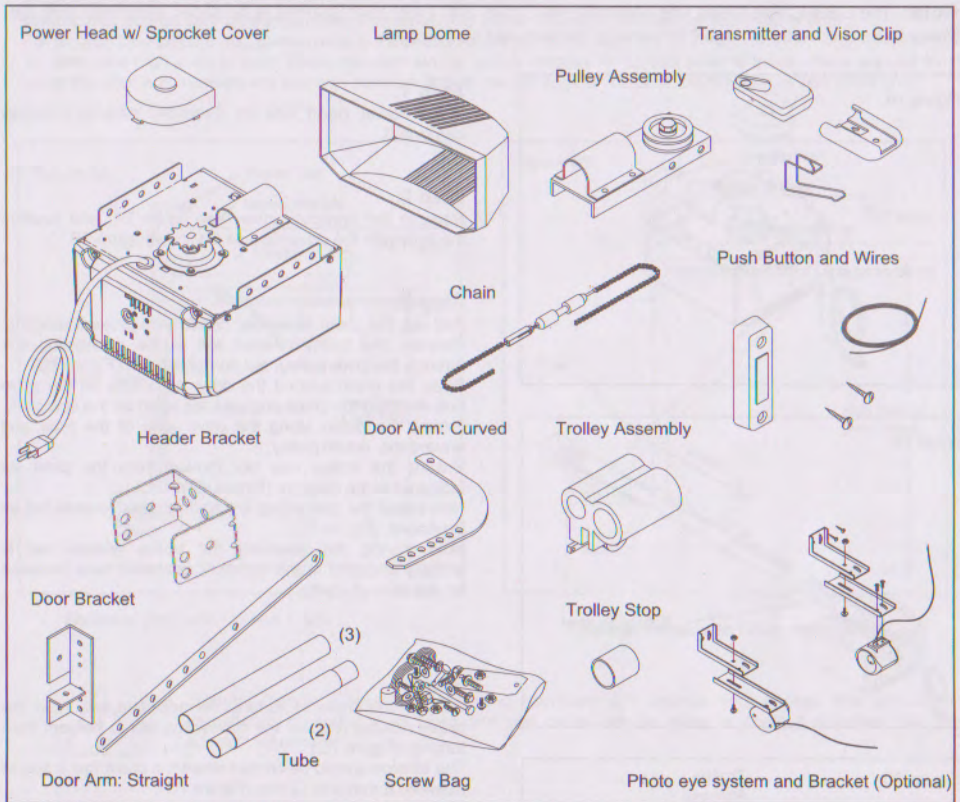

Fastener (parts in screw bag) Identification

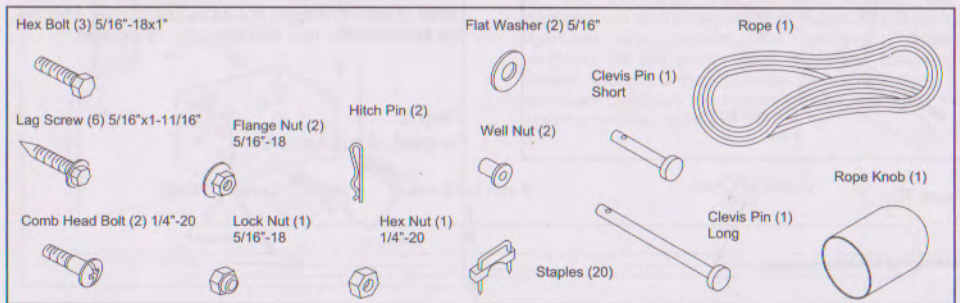

Assembly

Note: The L-Rail/Chain Speed Unit Assembly with Trolley and Front Idler Sprocket is packaged separately from the Power Head Unit. Refer to Page 6 for package contents and identification.

Figure 7A

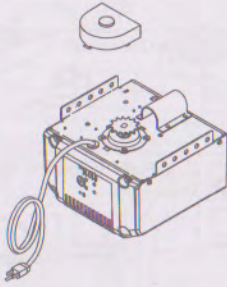

Step 1.

Place Power Head Unit on discarded packing material/ cardboard.

Step 2.

Remove the sprocket cover, see figure 7A, and position the trolley on the drive tube as illustrated figure 7B.

Step 3.

Roll out the chain assembly carefully to prevent tangling. Connect the trolley release rod to the connecting link through the drive trolley, but do not tighten. (Figure 7C)

Wrap the chain around the drive sprockets on the drive unit ensuring the chain engages the teeth on the sprocket. Extend the chain along the other side of the tube and around the return pulley.

Ensure the trolley has not moved from the point as indicated in the diagram (Figure 7B).

Now install the connecting link to the trolley release rod as illustrated. (Figure 7C).

Note: during the assembly the trolley release rod is actually engaged in the trolley. It is shown here removed for the sake of clarity.

Figure 7B

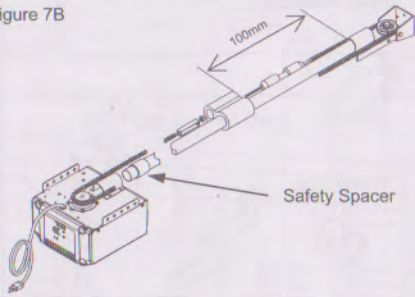

Step 4.

Tension the chain by turning the adjusting nut. Hold the trolley release rod and the connecting link to prevent from turning. (Figure 7C).

The tension should be correct when the chain has a sag of between 6 mm and 12 mm (Figure 7D).

Tighten lock nut against the connecting link, to lock adjustment into place (Figure 7C)

Figure 7C

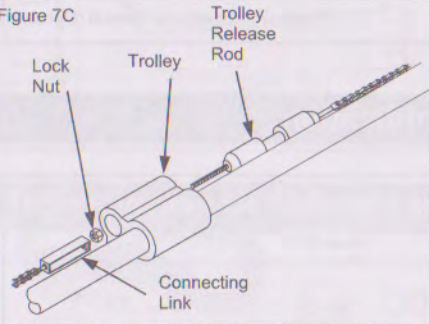

Note:

The chain and its supporting equipment may stretch after a period of time. The chain should be re-tightened after the first three months' use, and thereafter as required.

Figure 7D

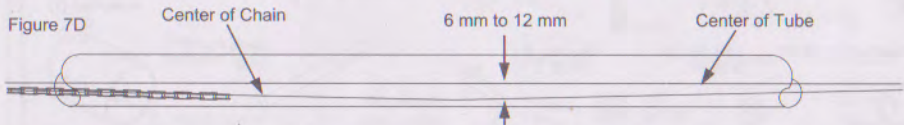

Assembly is now completed. You are ready to begin installation of the opener.

Installation

Installation procedures will vary depending on type of garage door.

Identify your garage door from those illustrated below and follow procedure outlined for your type of door.

For tilt door (one-piece door), please refer to installation on page 12&13.

To determine high point of door. Raise the door slowly, until it reaches its highest point of travel. Place support block under the door and measure the distance from the floor to the top edge of the door. Remove block and lower door.

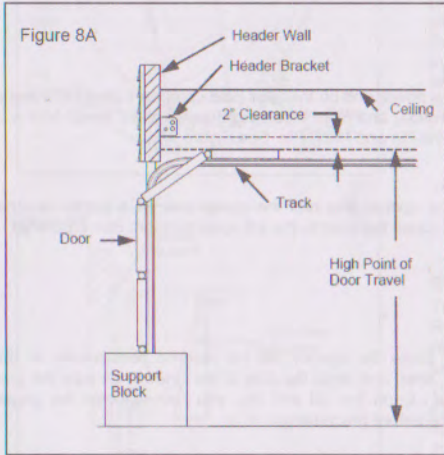

Sectional Door with Curved Track

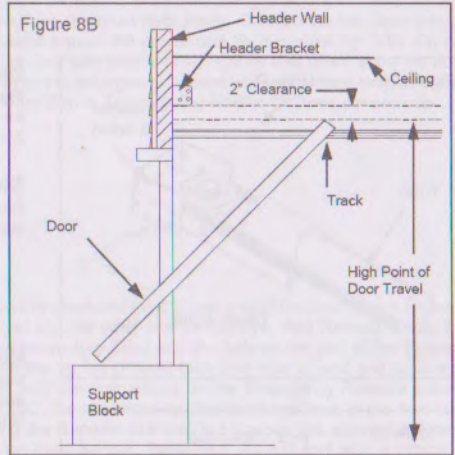

One-Piece Door with Horizontal Track



Springs, Pulleys, Cables and Mounting Hardware that balance your garage door are under tremendous pressure at all times and can cause serious injury or death if disturbed. Do not attempt adjustment!

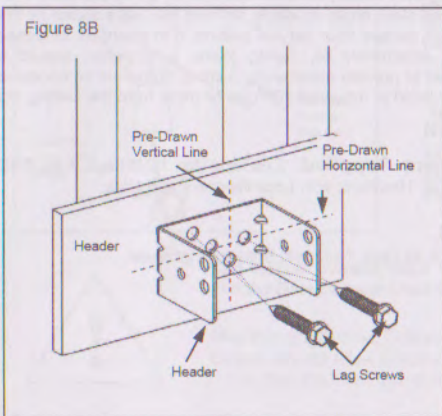

Step 1.

Mounting the front Bracket (Sectional Doors and One-piece with Track.) Mark a vertical centerline on the header above the door. By manually raising the door, determine the high point of the doors travel (see figure 8A and 8B) and using a level, transfer this measurement to the header (See figure 8C) Draw a horizontal line, crossing the previously drawn centerline, at this point. Install the front Mounting Bracket securely with lag screws as shown below. If necessary, reinforce the header with steel or wood to ensure a secure mount.

Installation



Warning: Aluminum or Lightweight Steel Doors Will Require Reinforcement before installation of door mounting brackets. Contact your door manufacturer instructions. Failure to properly do so may result in severe door damage.

Note: Reinforcing may affect the balance of your door. Check for proper manual operation after installation. If necessary have your door re-balanced by a qualified garage door service person.

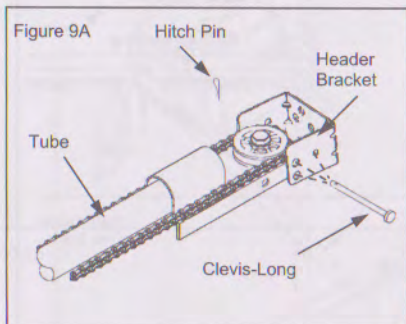

Step 2.

Place the power unit on the floor (use cardboard packing material for protection) and raise Mounting Bracket align. Insert 5/16 x 2-3/4" Clevis Pin and Hitch Pin. See Figure 9A.

Step 3.

Raise the opener and rest the power unit on a ladder or other support. Open the door to the full open position. See Figure 9B.

Note: Since the opener will be secured permanently in this position, open and close the door a few times to be sure the door does not rub on the rail and that you have allowed the proper clearance before proceeding.

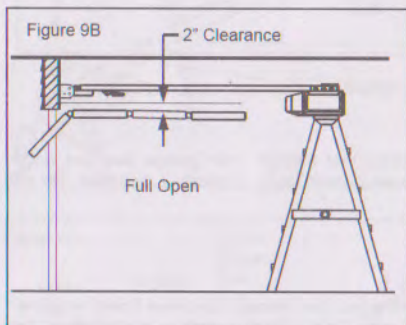

Step 4.

Mount Power Head to Ceiling:

Since there are many different ceiling designs, all possible mounting illustrations can not be shown. Primary concern is to secure the power head to the ceiling so that operational strength, rigidity and safety are achieved. The opener must be securely fastened to a structural support of the garage. Although there are a series of mounting holes provided on the power unit, try to secure the mounting hangers to the slots closest to the front. Mounting may usually be accomplished by using standard 1-1/4" perforated steel angle available at most hardware stores or from your local garage door service person. If in doubt as to location of, and attachment to, ceiling joists, a carpenter should be contacted to provide assistance. A cross brace will be necessary if power head is mounted 200 mm or more from the ceiling. See figure 9C.

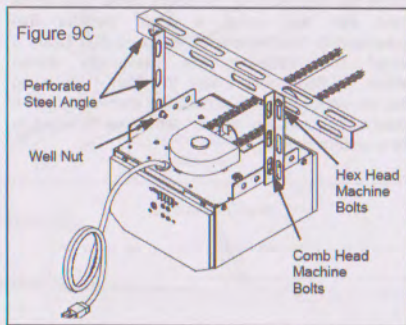

Fasteners Supplied: 2 ea. 5/16-18x 1-7/8 Lags, 4 ea, 5/16 - 18 x 1-1/8" Hex Bolts with Lock Washers and Nuts.

Step 5.

Re-check all Lags, Nuts and Bolts for Tightness.

Installation

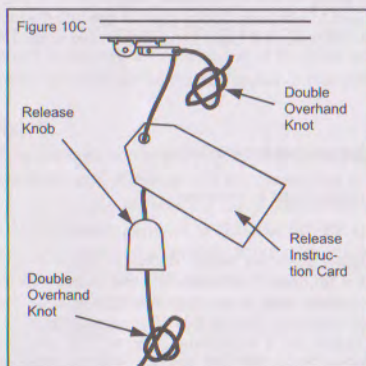
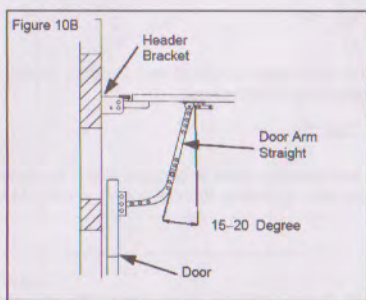
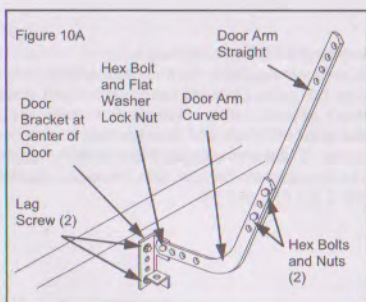

Step 6.

Door Arm, Bracket and Plate Installation:

Install the door mounting bracket on center and even with the top set of rollers on the door as illustrated Figure. 10A. (Fasteners Supplied: 2 ea. Lag Screw. Connect the straight door arm section (single hole section) to the trolley using a 5/16 x 1" Clevis pin and clip. The door arm must pivot freely. Connect the two Door arm so that it leans toward the power unit as illustrated fig. 10B. Do not install the door arm so that is straight up and down when the door is closed or the emergency release will not function properly. Now attach Door Arm to Trolley using 5/16" x 1" Clevis pin and clip.

Step 7.

Tie a double overhand knot in one end of the Emergency Release Rope and slip the other end through the Red Release Knob, the Release Instruction Card and the hole at the end of the Release Lever on the Trolley (Please take time now to read and familiarize yourself with the instructions on the Emergency Release Label) Figure 10C. Tie a second double overhand knot in the free end, adjusting the Rope so that the Red Knob is 2M. above the floor. If the Rope must be cut, flame seal the cut end with a match or lighter to prevent fraying or unraveling.

Note: The Emergency Release Mechanism is engaged by pulling the Release Knob down and towards the door, allowing the Trolley Mechanism to separate freeing the door. To re-engage simply move the Emergency Release Mechanism Lever upwards and operate the Opener using the push button or Transmitter. The two parts will automatically reconnect.

Note: This operation should be attempted only when the door is fully closed. Disconnection when open or partially open can cause the door to close quickly and cause personal injury or damage to the door.

Use Manual Release Rope to Disengage Trolley Only. Do Not Use the Rope and Knob to Pull the Door Open or Closed

Warning: A Child Operating the Door Controls Risks Injury - Or Death to Himself and to Others. Do not Allow Children to Operate Any Door Controls. Mount the Push Button at Least 1.5 M from the Floor Out of Reach of Children

Warning: Improper Door Operation can Cause Injury or Death. Caution Label Must Be Mounted on Wall Near The Push Button. All Warnings Should Be Strictly Adhered To.



Installation

Figure 11A

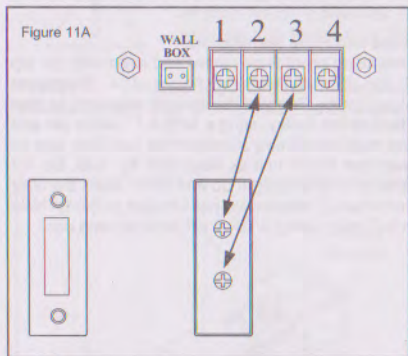

Warning: Installation & Wiring Must Be in Compliance with Local Electrical and Building Codes. Operation at other than 240V 50 Hz Will Cause Opener Malfunction and Damage.

Step 8:

Installing the Standard Wall Push Button

Remove about 6 mm of insulation from both ends of the 2 strands low voltage bell wire. Connect one end to both screw terminals on the back of push button. Select a convenient place near an access door, 1.5M ft from the floor and out of reach of children, for mounting. (2) Screws supplied. Run bell wire up the wall and across to the opener. Secure with insulated staples. Attach to Terminals 2 & 3 Figure 11A.

Step. 9

Opener Must be permanently wired or plugged into a grounded 3-prong receptacle wire according to local codes, within 1M of the Power Unit.

Step. 10

Install a 60 watt Rough Service Bulb (available at most hardware stores) firmly in the light socket. Light bulbs in Door Openers are subject to vibration during normal operation which may shorten their life span. Fit Light Lens Cover and snap into place.

Step 11

Setting Personal Transmitter Access Codes.

Your Opener contains a built in Receiver

To set Receiver:

With a pointed object push the button shown in figure 11C. If the courtesy light is off, then it will come on and stay on for 30 seconds. If the courtesy light is on, then it will flash once and then stay on for 30 seconds. During this 30 second time period push the round button on a transmitter (figure 11B) until the courtesy light flashes twice this will indicate that the receiver has accepted the code of the transmitter. If the code is not accepted, then the courtesy light will stay on for 30 seconds, flash 4 times and then stay on for 2 1/2 minutes. Up to 20 transmitters (including wireless keypad) can be programmed into the receiver in this way by repeating the process. Each transmitter has its own code set at the factory. If you enter more than 20 transmitters the oldest transmitter will be dropped from memory and the new transmitter will be added. To delete all transmitters from memory hold the receiver set button in for 5 seconds. The courtesy light will then flash 7 times, indicating all transmitters have been cleared from memory.

Figure 11B

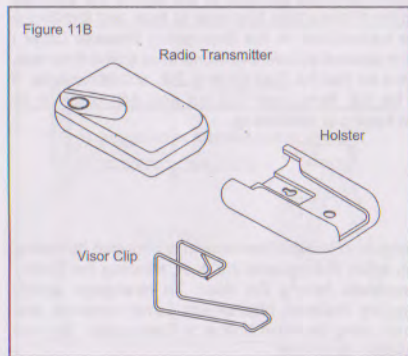
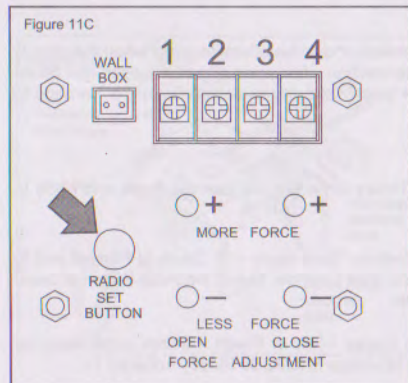

Figure 11C



Installation (Tilt Door)

Step 1:

Locate the center of the top edge of the garage door and mark it on the inside face. With a level set plumb at this mark, draw a vertical line on the mounting surface above the door. (If a ceiling surface suitable for marking exists, extend the line to the ceiling and mark the ceiling. Open the door and plumb up from the center mark made on the door to the ceiling, if one exists, and mark the ceiling. Determine the rise of the high arc of the door. Use level to measure rise on mounting surface above door. Use the table below to determine the distance the front end bracket should be mounted above the top of the door when closed.

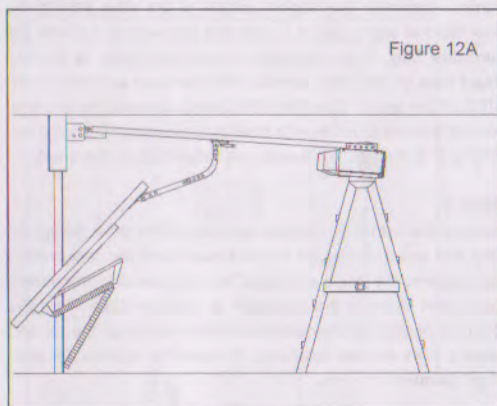

HIGH ARC RISE	MOUNTING DISTANCE
4 inches	8 inches
4 to 8 inches	13 inches
8 to 12 inches	18 inches

Make the appropriate measurement and mark the vertical line at this point.

Step 2:

Attach the bracket provided directly to the structure or the addition with lag screws or bolts and self locking nuts so that one leg of the bracket provides a shelf upon which the front end of the rail may be rested and subsequently attached. The leg of the bracket forming the shelf should be at the horizontal mark made in **Step 1**. The center hole in this leg should be aligned with the center of the door opening or the vertical line. The other leg of the bracket which is to be attached to the structure may be above or below the mark as the situation may require.

Step 3:

Place the front end of the rail on the bracket attached in **Step 2**, and drop one of the 1/4" x 2" carriage bolts through the hole in the end of the rail and the center hole in the bracket. Run one of the 1/4" nuts on the end of the bolt a few turns. This will temporarily hold the rail in place while the back end is swung upward and rested on a step ladder. **CAUTION: IF ADDITIONAL HEIGHT IS REQUIRED, BE CERTAIN THAT THE MEANS USED PROVIDES A STURDY AND STABLE NON-SKID PLATFORM. PULL THE CARRIER RELEASE ARM TO A VERTICAL POSITION AND SLIDE THE OUTER HALF OF THE CARRIER TO THE REAR OF THE RAIL. THIS WILL PREVENT THE DOOR FROM STRIKING THE LEVER.** At this time the door can be opened to its high arc position. It will be necessary to support the door so that it will remain in this position. Position the rail over the center of the top section of the door.

Lower and back end of the operator so that the bottom of the rail is about 1/2" above the door edge at the high arc position (Fig 13A). Do not allow the door to support the operator as this will cause a false measurement to be taken and possibly damage the door. Support the operator in the same fashion as before and measure the distance from the ceiling to the selected frame mounting slot. The length of the rear vertical supports will not be greater than this dimension.

Step 4:

A rear mount must be constructed to secure the rear of the operator to the ceiling. The distance from the operator to the ceiling structure has already been determined in **STEP 3**. Measure and cut the appropriate length of perforated angle iron or other suitable metal required to suspend the operator. The operator frame plate is 6 - 1/2" wide. The vertical supports should be 3 - 1/4" from each side of the center line. Construct the mount and secure it to the structure in the ceiling. Secure the operator to the mount. The mount must be braced to minimize lateral movement in all directions.

Installation (Tilt Door)

Figure 13A

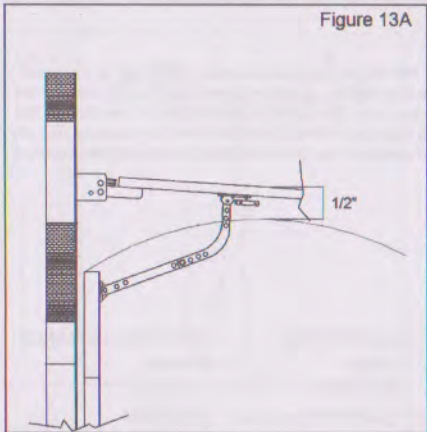
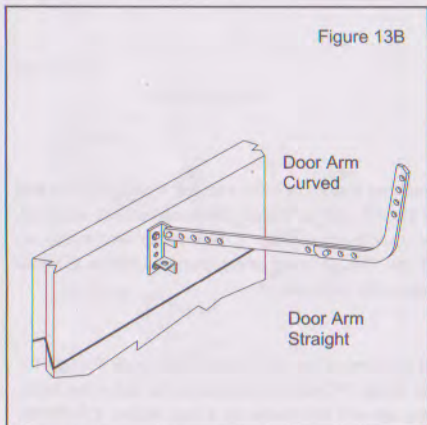

Figure 13B



Step 5:

After the rear of the operator is suspended, remove the door support and close the door. Remove the 1/4" x 2" carriage bolt and nut that was used to temporarily hold the front end of the rail to the bracket and secure with a 5/16" x 1" bolt and lock nut. Attach the straight portion of the door arm to the carrier by means of the 3/8" x 1" bolt and self locking nut already on the carrier. Assemble the angled portion of the door arm to the door bracket with a 3/8" x 1" bolt and self locking nut from the hardware bag. This connection should be made to the top round hole on the door bracket with the door arm on the **IN-SIDE** of the angle. (See Fig 13B). Next, connect the two sections of the arm together with three holes overlapping using two 5/16" x 1" bolts. (Make the nuts only finger tight at this time).

Step 6:

Release the carrier for manual operation of the door. Swing the door arm and door bracket up the forward until the door bracket rests against the inside surface of the door with the arm attachment point close to the top edge of the door (See Fig 13B). Note the position of the outer slide of the carrier on the rail and make a mark for later reference. Prepare the operator for electrical operation.

Step 7:

With the disconnect still in the release position, start the operator in the closing direction (carrier forward) by means of the pushbutton and allow it to stop on the DOWN limit setting. Should the position of the inner carrier slide not coincide with the position of the outer slide determined in **STEP 6.**, it will be necessary to re-position the DOWN limit cam so that the outer slide of the carrier stops as close as possible to this point. Move the DOWN limit roller assembly on the chain toward the door if more travel is needed; toward the operator head to reduce travel of the carrier.

Step 8:

When the **DOWN** limit position of the inner carrier slide and the position of the outer slide determined in **STEP 6**, coincide as closely as possible following the **DOWN** limit adjustment, re-connect the carrier slides. Swing the door arm up the forward until the door bracket rests against the inside face of the door. If the point of attachment of the door arm on the door bracket is within 1" of the top edge of the door, check vertical alignment of the door arm then mark the door for mounting holes. Use center hole and bottom of the lower slot. Drill two 1/4" holes and secure the bracket to the door with the carriage bolts provided. (NOTE: When drilling these holes, make sure that the drill, exiting through the front surface of the door, does not damage any overlapping trim.) Tighten the two 5/16" x 1" nuts and bolts which hold the two sections of the door arm together.

Step 9:

Again, release the carrier for manual operation. Using the pushbutton, run the carrier to its fully open (rear) position. Manually, raise the door to its fully open position and note the relative positions of the inner and outer carrier slides. If the two halves of the carrier do not coincide exactly, re-position the UP limit roller assembly on the chain until the inner slide stops, during electrical operation, just **AHEAD** of the outer slide (toward the door). Do not permit the inner slide to attempt to travel beyond the maximum rearward travel of the outer slide with the door in the fully open position.

Adjustment



Warning: If Limits are not adjusted properly, the emergency release mechanism may not work properly and door operation could result in door damage or serious injury.

Note: It is now necessary to turn on the power in order to run the opener to check limit settings. Before doing so, ensure that all mounting hardware is installed and has been properly tightened, that all electrical connections are per local code requirements. Double Check that all ropes have been removed and that the doorway is clear.

Figure 14A

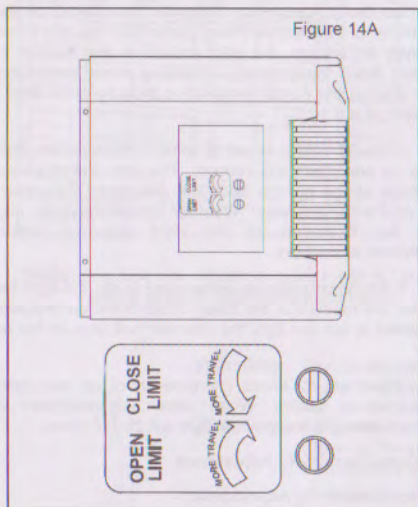

- Up (Open) and Down (Close) Limits
- Limit adjustments settings regulate the total amount of distance the door will travel while opening and/or closing.
- Setting the Up Down Limits
- Note: Run the Opener through a complete travel cycle after each adjustment.
- Note: Repeated Operation of Opener may cause the motor to Overheat and the Thermal Overload Protection System will shut off the Opener. Please wait approximately 15 minutes for the Opener to cool down and automatically reset.
- If the door opens completely and closes completely without reversing: No adjustment is necessary.
- If the door does not open completely but opens at least 1.5M: Increase Up travel by turning UP LIMIT screw Clockwise
- If the door does not open 1.5M: Adjust Up FORCE/ SENSITIVITY Setting Page 15.
- If Door does not close completely: Increase Down Travel by turning DOWN LIMIT screw Counter-Clockwise.
- If Door reverses in full closed position: Decrease Down travel by turning Down LIMIT screw Clockwise.
- If Door Continues to Reverse: Disconnect Door from Opener use manual release. Check for binding while working door manually. If door binds or is out of balance call a qualified garage door service person. If no binding is found and balance seems correct. Adjust FORCE/SENSITIVITY Setting Page 15.

Figure 14B

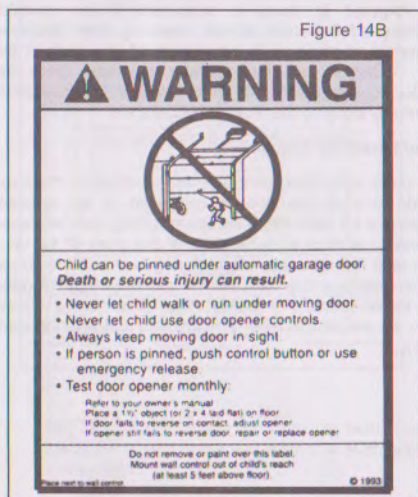

Force/Sensitivity Adjustment



Warning: Improper Adjustment of Sensitivity System Force Could Cause Entrapment, Injury or Death. Set The Adjustment For Just Enough Force To Operate The Door Reliably, But No Stronger. Do Not Over-Adjust Force/Sensitivity System To Compensate For A Poorly Working, Sticking or Binding Door (Contact a qualified Garage Door Service Person to Correct any binding, sticking and/or other door problems).

Figure 15A

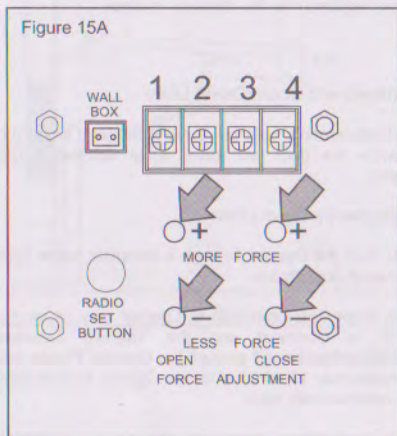

Force/Sensitivity Adjustment

- Force/Sensitivity Adjustment Controls are located on the Back Panel of the Opener (See Figure 15A). Up and Down sensitivity adjustment are independent of one another (+ indicates more force) and (- indicates more sensitivity). Never change the Force/Sensitivity setting by more than 1 increment at a time.
- **Note:** Force/Sensitivity is set at level 1 at the factory both for the up and down adjustments. The size and operating conditions of the garage door will determine the correct level of Force/Sensitivity. Weather conditions may also affect the operation of the door requiring further adjustments as needed.
- **Note:** If the down pressure adjustment is set too light the operator will reverse in the down cycle. If the up pressure adjustment is set too light the operator will stop in the up cycle.
- **Note:** There are 12 levels (increments) of up and down force/sensitivity setting. When either the maximum or minimum setting is reached the light will flash 6 times.

Setting Force/Sensitivity Adjustment

Down force/Sensitivity Adjustment

- In the down or close direction the operator will reverse if the force required to close is exceeded. If the operator completes a full closure without reversing, then decrease the amount of pressure in increments of one push of the down - button until the operator reverses. Once the operator does reverse in the down direction increase down pressure by pushing the down + button once.

Up Force/Sensitivity Adjustment

- In the up or open direction the operator will stop if the force required to open the door is exceeded. If the operator completes a full open cycle without stopping, then decrease the amount of force in increments of one push of the up - button until the operator stops during the up cycle. Once the operator does stop increase the up force by pushing the up + button once. For safety, the force setting should always be set at the least amount and still run the door properly.

Testing the Safety Reverse System



Warning: Failure to Test Reversing System Could Result in Death or Serious Injury. Test This System Once A Month.

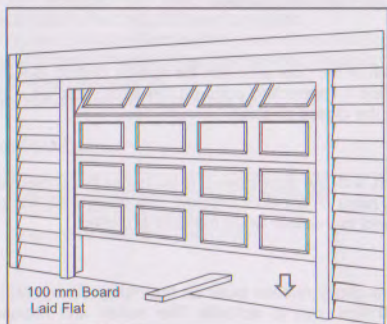

Test the Opener Reversing Feature at floor level, place a solid object 100 mm thick on the ground so the center of the door will contact it. Close the Door. If the Down force Adjustments are Correct, the door will reverse within one and a half (1-1/2) seconds of contacting the object and travel to the Full Open Position. Light will also start flashing and continue to flash for 30 seconds. If this does not occur, re-check Limit Adjustments Page 14 and Force/Sensitivity Adjustments Page 15.

Note: Any time any adjustments are made to Limits or Sensitivity, You Must Retest the opener for the Reversing Feature at Floor Level as outlined above.

Warning: The Sensitivity System Reversing Test Should Be Performed Monthly to Ensure That This Important System Remains in Proper Adjustment



Warning: A Damaged or Malfunctioning Photo eye system Could Cause a Garage Door to Close on People or Property And Causing Serious Injury or Death. Perform this Test Monthly to Ensure Proper Operation.

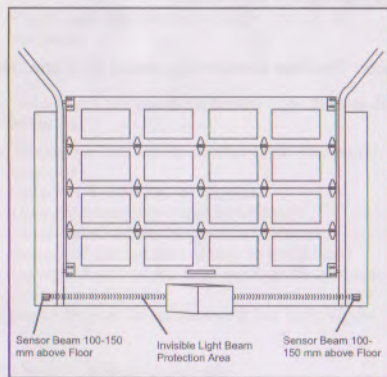

Testing the Photo eye system

Start the door down and then place an obstacle approximately 200 mm high by 300 mm wide in the path of the beam. The Red Pilot Light on the Silent Guard Photo eye system should go off. The door should stop for 1-1/2 seconds and reverse to the full open position. The Opener light will also begin flashing and continue to flash for 30 seconds. IF the door is moving up and the beam is broken, the door will continue move up to full open. With the door fully open and at rest position, place the obstacle in the path of the beam once again. Activate the Wall Push Button, The Opener will revert to and remain in the safety. Push And Hold Operation for close travel.

NOTE: If the Garage Door Travels More Than One Inch in a Downward Path After Releasing the Button, then the Silent Guard Photo eye system is Malfunctioning. Check All Electrical connections and Alignment of the Photo eye system.

Final Installation

Make Sure That:

1. The front and rear mounts for the opener are sound and secure and the rail is positioned correctly above the high arc of the door and that the opener is positioned over the door action centerline.
2. For sectional doors and one-piece doors with tracks, the position of the door arm with the opener closed, is such that its connecting point on the trolley is 125 to 200 mm behind its connecting point on the door bracket. The door arm should never be perfectly vertical when the door is in the closed position.

For one piece doors without tracks, the position of the door arm, with the door closed, is such that its connecting point on the trolley is 500 mm to 550 mm behind its connecting point on the door bracket. The straight portion of the door arm should be at an angle of 15-20 degrees with respect to the floor when the door is closed.
3. The emergency release knob and cord are secured to the emergency release lever on the trolley. The knob is located 2M above the floor and requires no more than 20 Kgs. pull to actuate. The trolley and release mechanism are properly lubricated.
4. The standard lighted wall push button is in such a position and at such a height that it can only be actuated by an adult. The caution label is prominently displayed next to the push button.
5. All wiring is correct to code. There is ground continuity in the supply. The ground prong on the power cord is intact.
6. All ropes have been removed from the door. The door moves freely without binding when operated manually. The door is correctly balanced and lubricated. All door hardware is secure and sound. The sensitivity has been adjusted to minimum force. The appropriate warning sticker has been affixed to the door.
7. The door reverses on obstructions to within 50 mm of the floor. The floor beneath the closed door provides uniform contact.

Trouble Shooting

Symptoms	Probable Cause/Solution
Opener does not work from either the transmitter or push button.	1,2,3,5,6,9,11,17,23,24
Opener does not start on command and light flashes for 30 seconds	1,4,5,7,8,11,12,13,15,16,17,18,22,23,24
Opener stops during cycle and light flashes 5 times	6
Opener operates from push button but not radio	9,14,20,21,25
Stops before reaching full open or closed	10,15
Reverses when the door makes contact with the floor	10
Light flashes 5 times but the opener does not start	26
Light does not come on	5,19
Light will not turn off (Light stays on)	5

Probable Cause	Solution
1. Mechanical garage door lock is engaged	1. Remove all locks from the garage door
2. Power is not present at outlet.	2. Check circuit breakers, fuse box and GFI receptacle
3. Shorted or defective push button.	3. Remove push button from wall and disconnect wires from the push button (activate transmitter). If the operator works from transmitter replace push button.
4. Bell-wire is shorted	4. Disconnect bell wire from the terminal stripe on the back of the power head (activate transmitter).
5. Malfunctioning logic board	5. Unplug operator at power outlet and then reconnect. Consult repairman to replace logic board.
6. Thermal overload breaker protection has been activated.	6. Allow time for motor to cool down (15 to 30 minutes depending on temperature in the garage). Thermal breaker automatically resets itself.
7. Garage door springs are out of balance	7. Consult service repairman to balance or replace springs.
8. Garage door is jammed.	8. Operate garage door manually; disconnect opener by pulling red cord on the trolley. Look for binding or jamming of the garage door. Consult service repairman.
9. Weak transmitter battery	9. Replace 12-volt battery in the transmitter by removing the screws on the backside of the transmitter case and pulling the case open to expose battery.
10. Travel limits are out of adjustment	10. Refer to page 14 in the installation manual.
11. Photo eyes are obstructed (light flashes 30 seconds)	11. Check for obstructions between the photo eyes and remove obstruction.
12. Photo eyes are out of alignment (light flashes 30 seconds)	12. Check red LED inside the lens of the receiver photo eye (photo eye with 4 wires). Led will light up when photo eyes are aligned properly, refer to page 12 & 13 in the installation manual.
13. Photo eye bell wire is shorted (light flashes 30 seconds)	13. Replace existing bell wire with new. Make sure that insulated staples do not short wire.
14. Defective transmitter or receiver	14. Contact your local dealer.
15. Up force/sensitivity out of adjustment	15. Adjust up force/sensitivity see page 15.
16. Down force/sensitivity out of adjustment	16. Adjust down force/sensitivity see page 15.
17. Bottom of garage door frozen to the ground	17. Free bottom of the door from the ice.
18. Foreign object on the floor such as ice or snow.	18. Clear all foreign objects from under the door.
19. Defective light bulb	19. Replace with rough service bulb of 60 watts or less.
20. Radio receiver is not receiving the radio signal	20. Point wire antenna straight down towards the floor. Ensure radio signal (transmitter) has a direct line of site to the receiver. Radio signals do not pass through metal objects but do penetrate glass.
21. Location of radio transmitter	21. Contact your local dealer.
22. Defective RPM counter board.	22. Contact your local dealer.
23. Defective programming board	23. Contact your local dealer.
24. Defective photo eyes	24. Contact your local dealer.
25. Defective transmitter	25. Contact your local dealer.
26. Vacation switch is activated on the deluxe 3 function wall stations.	26. Switch back to Vacation off position.

After the Installation

1. Never permit children to play with or operate the garage door opener either from the wall station or the remote controls. Keep radio transmitter locked in the car. Misuse of the push button or transmitter could result in serious injury or even death.
2. Open the garage door with the remote controls only when the garage door is fully visible to you and clear of all obstructions. The garage door should be kept in sight until it is completely open or closed and you are certain that the garage door opener has shut off.
3. Attempting to exit the garage through the garage door opening, while the door is in motion, is a very dangerous activity that could result in serious injury or even death.
4. Children and pets should always be clear of the door opening while the garage door is in motion.
5. Check the safety reverse mechanism at least once a month to make sure that it will reverse with the minimum amount of force. Also check to be sure that the door will reverse within 100 mm of the floor. See page 16.
6. Check the manual operation of your garage door at least every 90 days to be sure that it is operating smoothly and does not bind or stick. Tighten all bolts on the door and visually check all hardware including springs for wear or damage. Caution: If service is needed contact your local garage door service person.
7. Do not decrease the safety reversing sensitivity mechanism to overcome a damaged or poorly operating door. This will adversely affect the operation of the safety reverse mechanism which could result in damage to the door, personal injury or even death.

Caution: Never operate the door opener if the reversing mechanism is not functioning properly.

8. Whenever possible, the manual disconnect should only be used when the door is fully closed. Caution: Extreme care must be taken whenever the disconnect cord is pulled with the door partially open. Weak or broken springs may allow the door to fall rapidly resulting in property damage, personal injury or death. If a broken spring is evident, contact your local garage door service person immediately before disconnecting the door from the opener. Never attempt servicing a broken spring.
9. Always disconnect electrical power supply to the opener when performing any maintenance or service to the opener or garage door. Failure to do so could result in electrical shock, property damage, personal injury or death.
10. If any damage to any mechanical or structural component of the opener is observed, discontinue use and contact your local garage door service person immediately.

Rail and Hardware Parts List

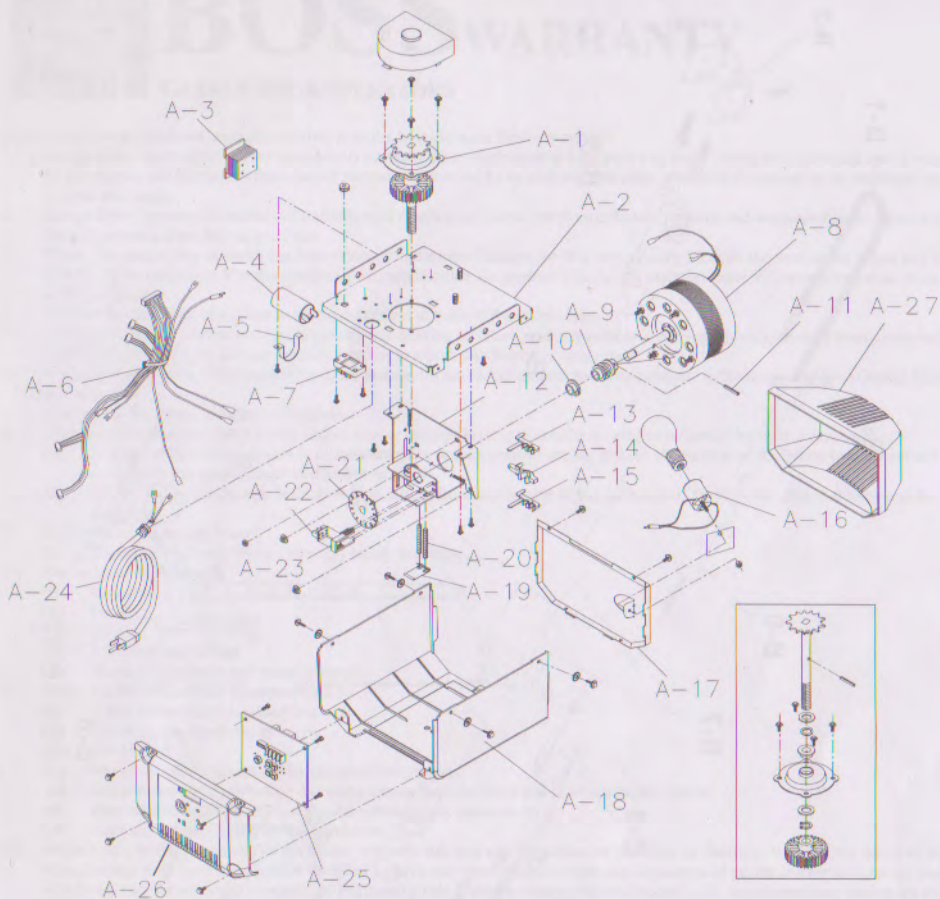

A-1	Drive Shaft Assembly w/ Helical Gear	A-10	Motor Shaft Bushing	A-19	Limit Shaft Clip
A-2	Chassis	A-11	Roll Pin	A-20	Limit Screws
A-3	Transformer	A-12	Motor Mounting Bracket	A-21	RPM Reader Wheel
A-4	Capacitor	A-13	Up Limit	A-22	RPM Reader Board
A-5	Capacitor Mounting Bracket	A-14	Limit Actuator (Traveler)	A-23	RPM Reader Board Bracket
A-6	Wiring Harness	A-15	Down Limit	A-24	Power Cord
A-7	Thermal Block	A-16	Light Socket	A-25	Logic Board
A-8	Motor	A-17	Front Panel	A-26	Back Panel
A-9	Worm Gear	A-18	Wrap Cover Assembly	A-27	Light Lens

Rail and Hardware Parts List

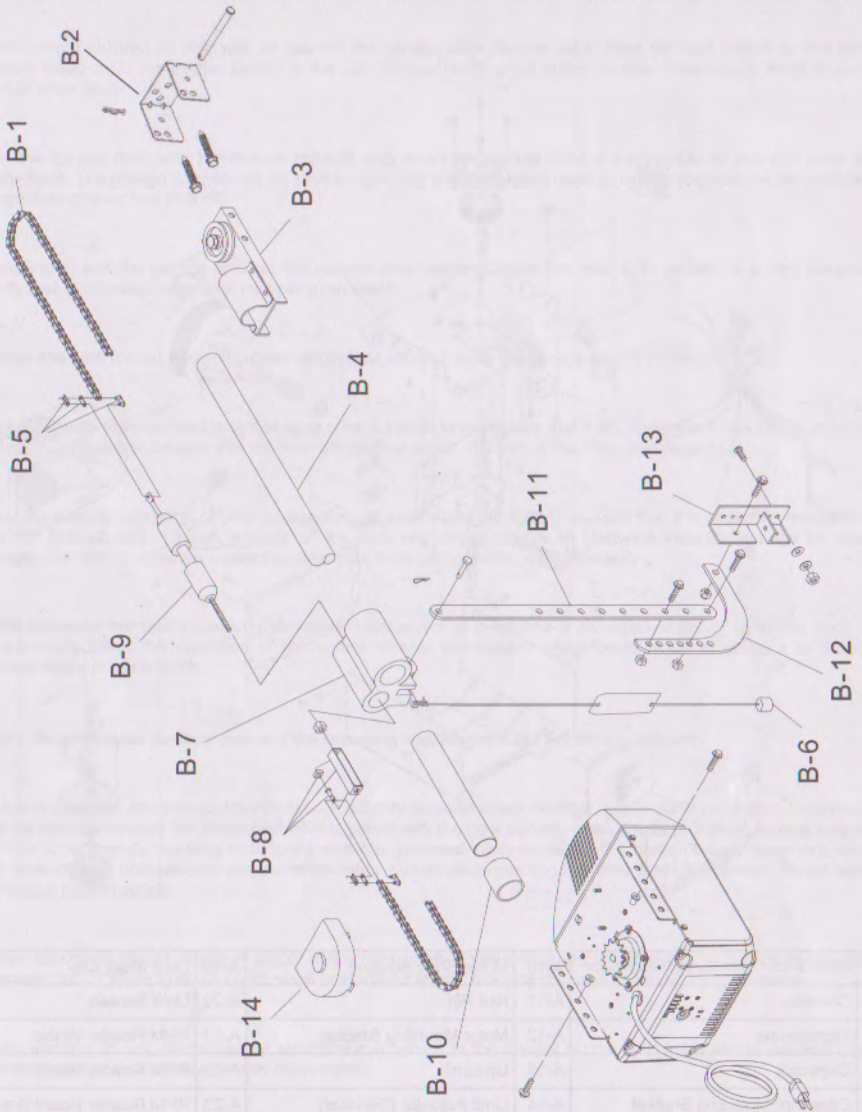

B-1	Chain	B-6	Emergency Pull-Cord with Knob	B-11	Straight Door Arm
B-2	Header Bracket	B-7	Trolley Assembly	B-12	Curved Door Arm
B-3	Pulley Assembly	B-8	Chain Tension Assembly	B-13	Door Bracket
B-4	Tube	B-9	Trolley Release Rod	B-14	Sprocket Cover
B-5	Chain Connecting Link	B-10	Trolley Stop		

BOSS WARRANTY

GARAGE DOOR OPERATORS

Boss Garage Door Operators hereafter referred to as the Manufacturer hereby warrants:

- Garage Door Operators to be free from defects in material and workmanship for a period of five (5) years for motors and one (1) year for Electronics and Mechanics from date of purchase, if installed by an authorized reseller, otherwise if installed by the purchaser one (1) year will apply.
- Garage Door Operators (Commercial and Industrial Application) to be free from defects in material and workmanship for a period of three (3) months from date of purchase.
- Where the garage door operator has been returned to the manufacturer for Warranty repairs, all costs incurred in the return will be paid for by the purchaser. If in the opinion of the manufacturer the product is faulty, all defective parts will be replaced at no charge to the purchaser.
- Proof of purchase must be given to the manufacturer at time of Warranty claim.
- The manufacturer reserves the right to modify any existing or future products without incurring any obligation to incorporate such modification to products already manufactured or to which this Warranty may relate.
- Warranty only applies if this product has been installed to the Manufacturers recommendation (in the opinion of Boss Garage Door Operators).
- This is only for goods installed in Australia.
- This Warranty does not apply to any defect, loss or damage arising or caused directly or indirectly by or as a result of :
 - Any defect (including defects in component parts or accessories) arising from or attributable to the failure to carry out normal preventive maintenance or adjustment itself.
 - To any additional damage or deterioration arising from attributable to the operation of the Operator after it is known to be defective.
- Exclusions to Warranty Period:
 - Repair or Warranty Work - three (3) month warranty
- Not included in Warranty:
 - Batteries.
 - Fuses.
 - Globes.
 - Sensitivity adjustment.
 - Hand Transmitters and receiver range.
- Note : All Warranties will be void subject to:
 - Water damage and condensation.
 - Power supply black out or surge.
 - Act of God.
 - Modification or adjustment by unauthorized persons.
 - Any interference from radio (including citizen band radios or and other electronic device.
 - Preventative maintenance and regular servicing not undertaken.
 - Account not paid in full by the purchaser.
- Subject only to the provisions of the Trade practices Act and any legislation of the State or Territory wherein the doors of the Manufacturer shall have been sold or installed (which may confer certain rights on consumers of goods and those rights by such legislation may be rendered incapable of exclusion) this Warranty supersedes and excludes all representations, warranties and conditions whether expressed or implied by law and the Manufacturer shall have no liability or otherwise than herein provided for any loss and damage (including consequential loss and damage, loss of use or profits) by reasons of delay, defective or faulty materials or workmanship, negligence or any act, matter or thing done permitted or omitted to be done by the Manufacturer.

WARRANTY

THIS WARRANTY FORM SHOULD BE COMPLETED AT TIME OF INSTALLATION

This Warranty Form should be retained by the purchaser at all times and produced with the purchase docket by the Purchaser as proof of the purchase date.

PURCHASE'S NAME: _____

PURCHASE'S ADDRESS: _____

INSTALLED BY: _____

INSTALLER'S ADDRESS: _____

INSTALLER'S SIGNATURE: _____

DRIVE UNIT SERIAL NO: _____

Boss Garage Door Operators
27Clinker Street, Darra, Qld 4076
Ph:(07) 3376 4988 Fax:(07) 3376 7071