

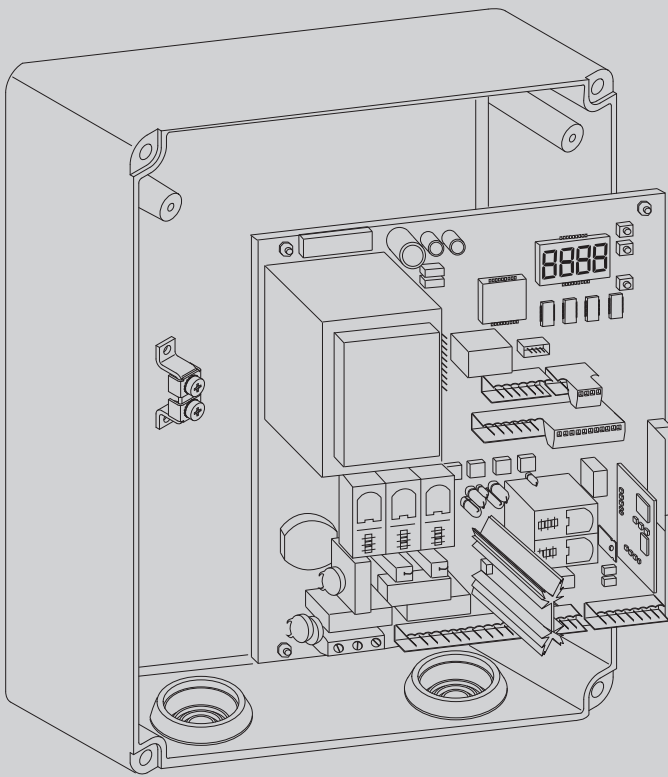

D811472.00100_01.29-10-09

CENTRALINA UNIVERSALE PER IL CONTROLLO DI UNO O DUE MOTORI
 UNIVERSAL CONTROL UNIT FOR OPERATING ONE OR TWO MOTORS
 UNITE DE COMMANDE UNIVERSELLE POUR LE CONTROLE D'UN OU DEUX MOTEURS
 UNIVERSALSTEUERUNG FÜR EINEN ODER ZWEI MOTOREN
 CENTRAL UNIVERSAL PARA EL CONTROL DE UNO O DOS MOTORES
 CENTRAL UNIVERSAL PARA O CONTROLO DE UM OU DOIS MOTORES

RIGEL 5



ISTRUZIONI D'USO E DI INSTALLAZIONE
 INSTALLATION AND USER'S MANUAL
 INSTRUCTIONS D'UTILISATION ET D'INSTALLATION
 INSTALLATIONS-UND GEBRAUCHSANLEITUNG
 INSTRUCCIONES DE USO Y DE INSTALACION
 INSTALLATIEVOORSCHRIFTEN

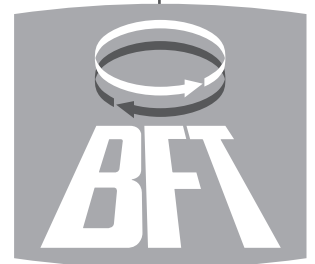

AZIENDA CON SISTEMA DI GESTIONE
 INTEGRATO CERTIFICATO DA DNV
 = UNI EN ISO 9001:2000 =
 UNI EN ISO 14001:2004

Attenzione! Leggere attentamente le "Avvertenze" all'interno! **Caution!** Read "Warnings" inside carefully! **Attention!** Veuillez lire attentivement les Avertissements qui se trouvent à l'intérieur! **Achtung!** Bitte lesen Sie aufmerksam die „Hinweise“ im Inneren! **¡Atención!** Leer atentamente las "Advertencias" en el interior! **Let op!** Lees de "Waarschuwingen" aan de binnenkant zorgvuldig!

INSTALLAZIONE VELOCE-QUICK INSTALLATION-INSTALLATION RAPIDE SCHNELLINSTALLATION-INSTALACIÓN RÁPIDA - SNELLE INSTALLATIE

ITALIANO

ENGLISH

FRANÇAIS

DEUTSCH

ESPAÑOL

NEDERLANDS

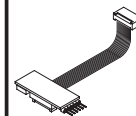
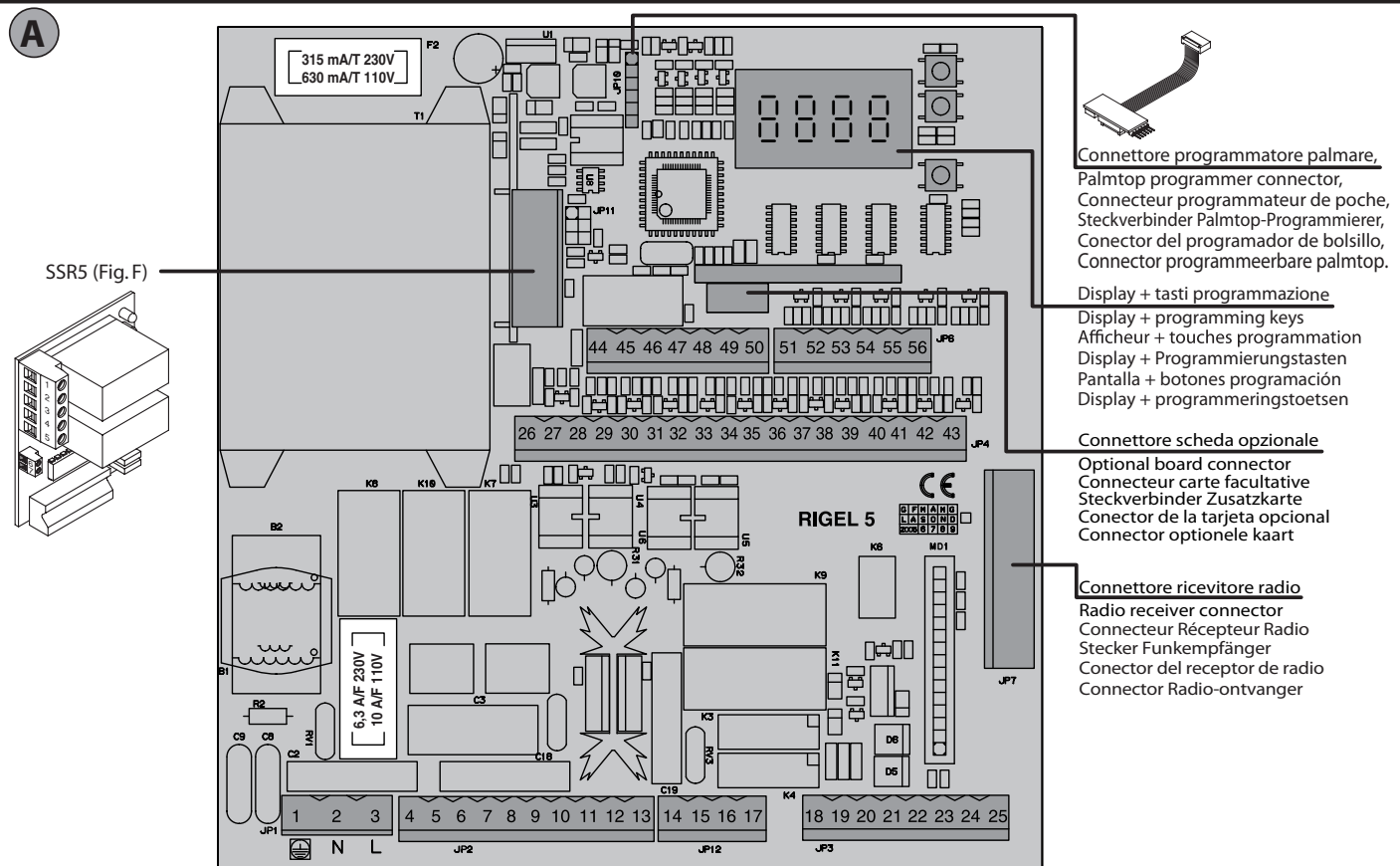

Connettore programatore palmare,
Palmtop programmer connector,
Connecteur programmeur de poche,
Steckverbinder Palmtop-Programmierer,
Conector del programador de bolsillo,
Connector programmeerbare palmtop.

Display + tasti programmazione
Display + programming keys
Afficheur + touches programmation
Display + Programmierungstasten
Pantalla + botones programación
Display + programmeringstoetsen

Connettore scheda opzionale
Optional board connector
Connecteur carte facultative
Steckverbinder Zusatzkarte
Conector de la tarjeta opcional
Connector optionele kaart

Connettore ricevitore radio
Radio receiver connector
Connecteur Récepteur Radio
Stecker Funkempfänger
Conector del receptor de radio
Connector Radio-ontvanger

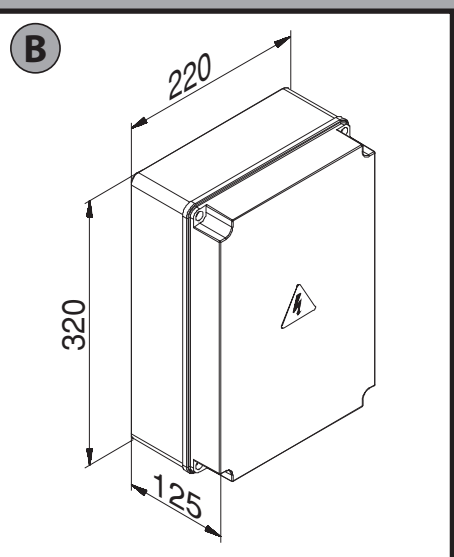
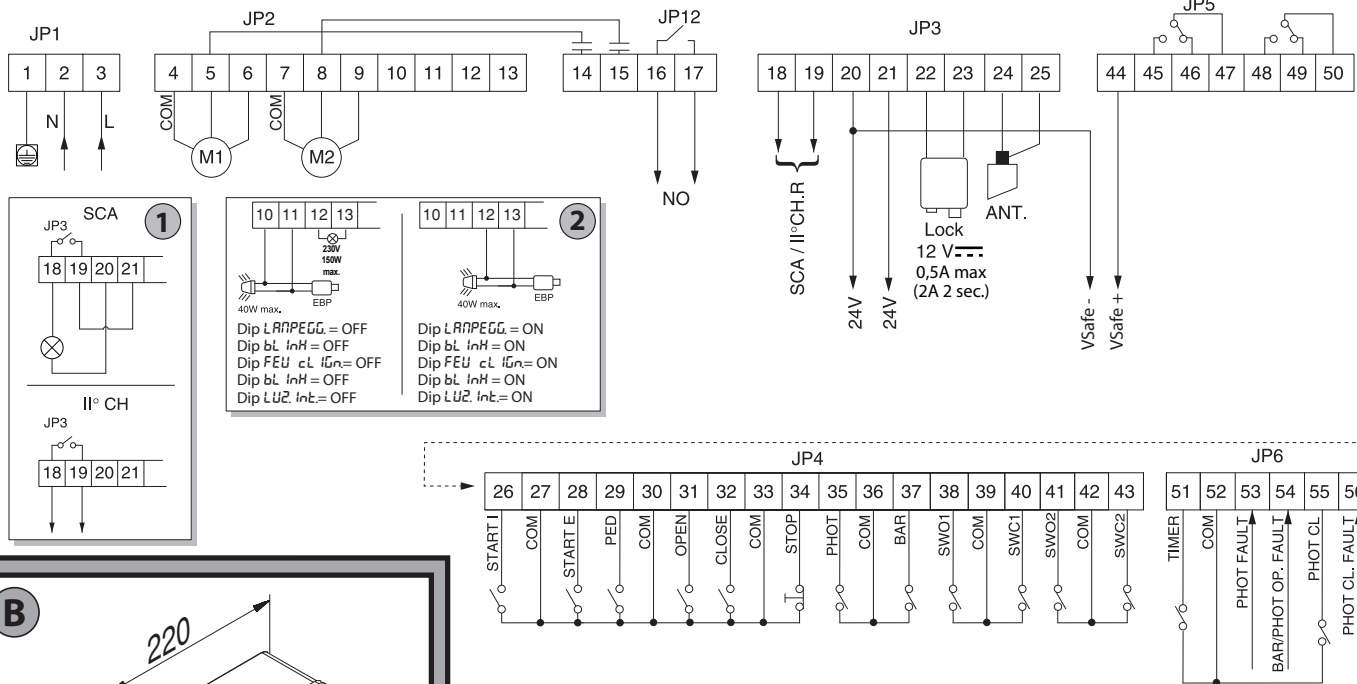

C Collegamento di 1 coppia di fotocellule non verificate, Connection of 1 pair of non-tested photocells, Connexion 1 paire photocellules non vérifiées, Anschluss von einem Paar nicht überprüften Fotozellen, Conexión de 1 par fotocélulas no comprobadas, Aansluiting van 1 paar fotocellen anders dan "trusted device"

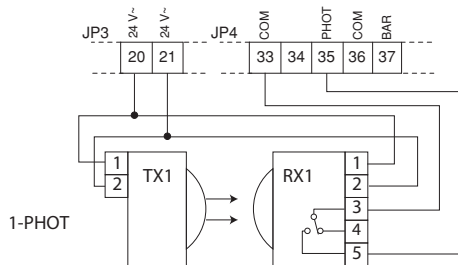

LOGICA test fotocellule OFF
Photocell test LOGIC OFF
LOGIQUE essai photocellules Désactivée
LOGIK Test Fotozellen OFF
LÓGICA prueba fotocélulas OFF
LOGICA test fotocellen OFF

SYSTEM SETTINGS MENU

LEGENDA

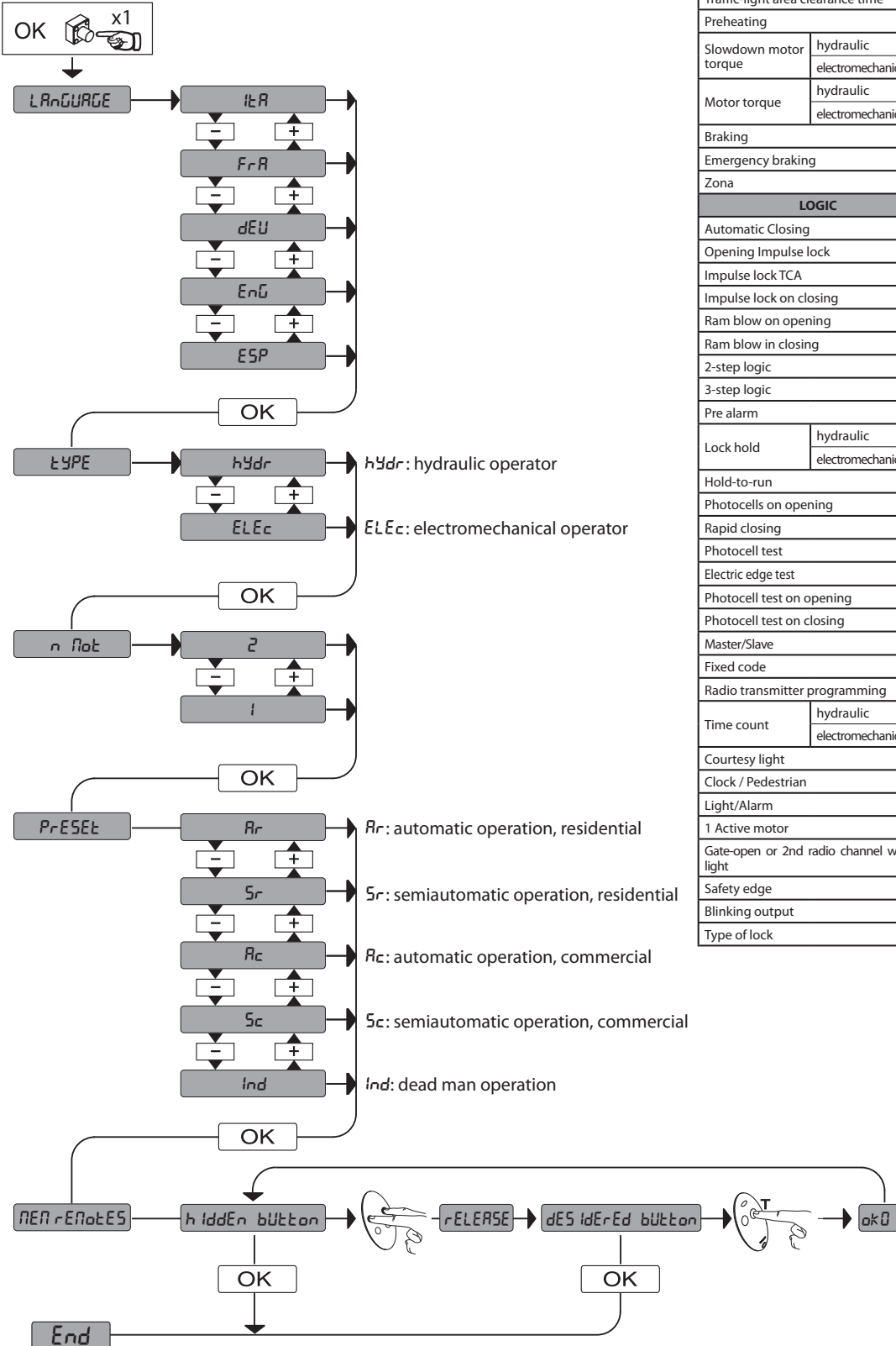
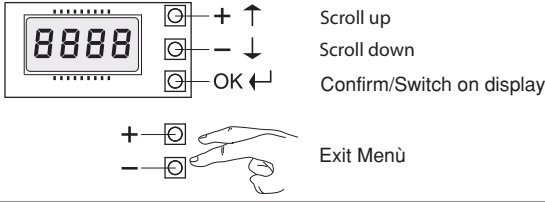

PRESET	DEFAULT	Rr	Sr	Rc	Sc	Ind
PARAMETER						
Automatic closing time (TCA)	40	20	40	30	40	40
Operation time motor 1	60	20	20	20	20	20
Operation time motor 2	60	20	20	20	20	20
Pedestrian operation time	6	6	6	6	6	6
Opening delay time for leaf 1	3	2	2	2	2	2
Closing delay time for leaf 2	3	2	2	2	2	2
Slow-down time	hydraulic	0	0	0	0	0
	electromechanical	3	3	3	3	3
Traffic-light area clearance time	15	15	15	15	15	15
Preheating	30	30	30	30	30	30
Slowdown motor torque	hydraulic	40	99	99	99	99
	electromechanical	50	50	50	50	50
Motor torque	hydraulic	40	99	99	99	99
	electromechanical	50	50	50	50	50
Braking	0	0	0	0	0	0
Emergency braking	60	60	60	60	60	60
Zona	0	0	0	0	0	0
LOGIC						
Automatic Closing	OFF	ON	OFF	ON	OFF	OFF
Opening Impulse lock	OFF	OFF	OFF	ON	ON	OFF
Impulse lock TCA	OFF	OFF	OFF	OFF	OFF	OFF
Impulse lock on closing	OFF	OFF	OFF	OFF	OFF	OFF
Ram blow on opening	OFF	OFF	OFF	OFF	OFF	OFF
Ram blow in closing	OFF	OFF	OFF	OFF	OFF	OFF
2-step logic	OFF	OFF	OFF	OFF	OFF	OFF
3-step logic	OFF	ON	OFF	ON	OFF	OFF
Pre alarm	OFF	OFF	OFF	ON	ON	OFF
Lock hold	hydraulic	ON	ON	ON	ON	ON
	electromechanical	OFF	OFF	OFF	OFF	OFF
Hold-to-run	OFF	OFF	OFF	OFF	OFF	ON
Photocells on opening	OFF	ON	ON	ON	ON	OFF
Rapid closing	OFF	OFF	OFF	OFF	OFF	OFF
Photocell test	OFF	OFF	OFF	OFF	OFF	OFF
Electric edge test	OFF	OFF	OFF	OFF	OFF	OFF
Photocell test on opening	OFF	OFF	OFF	OFF	OFF	OFF
Photocell test on closing	OFF	OFF	OFF	OFF	OFF	OFF
Master/Slave	OFF	OFF	OFF	OFF	OFF	OFF
Fixed code	OFF	OFF	OFF	OFF	OFF	OFF
Radio transmitter programming	ON	ON	ON	ON	ON	OFF
Time count	hydraulic	OFF	OFF	OFF	OFF	OFF
	electromechanical	ON	ON	ON	ON	ON
Courtesy light	OFF	OFF	OFF	OFF	OFF	OFF
Clock / Pedestrian	OFF	OFF	OFF	OFF	OFF	OFF
Light/Alarm	OFF	OFF	OFF	OFF	OFF	OFF
1 Active motor	OFF	----	----	----	----	----
Gate-open or 2nd radio channel warning light	OFF	OFF	OFF	OFF	OFF	OFF
Safety edge	ON	ON	ON	ON	ON	ON
Blinking output	OFF	OFF	OFF	OFF	OFF	OFF
Type of lock	OFF	OFF	OFF	OFF	OFF	OFF

ACCESS TO MENUS Fig. 1

D811472 00100_01

LEGENDA

⬆ + ⬆ Scroll up

⬇ - ⬇ Scroll down

⬅ OK ⬅ Confirm/Switch on display

+ ⬅ Exit Menu

- ⬅ Exit Menu

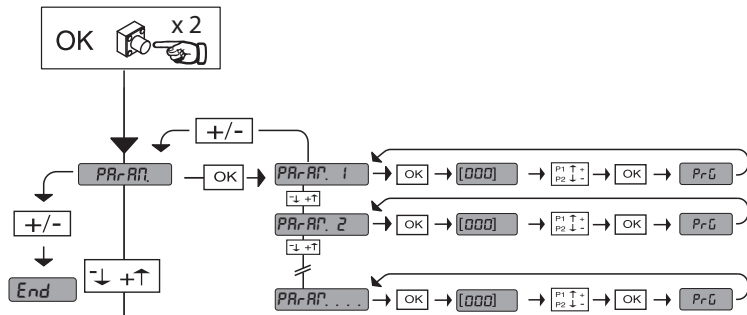

See PARAMETERS MENU

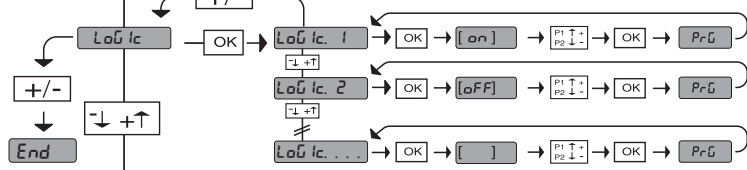

See LOGIC MENU

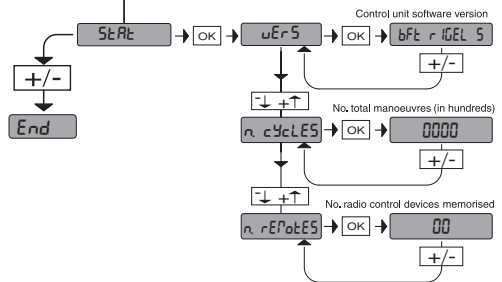
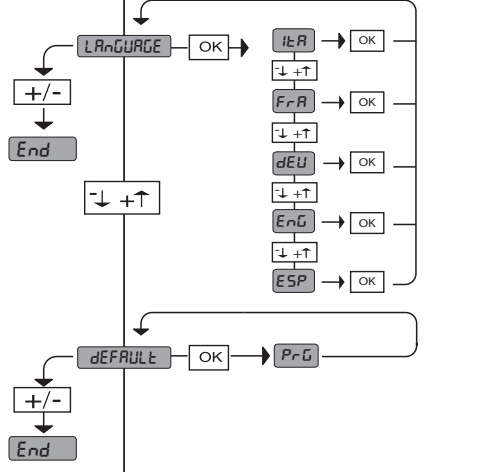
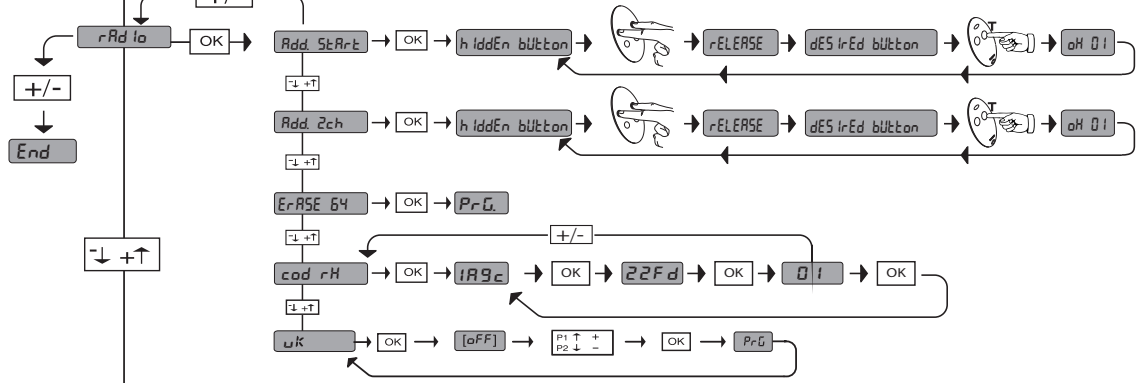

DIAGNOSTICS and WARNINGS		
DIAGNOSTICS CODE	DESCRIPTION	NOTES
StErE	EXTERNAL START input activation	
StEr I	INTERNAL START input activation	
PEd	input activation PEDESTRIAN	
oPEn	OPEN input activation	
cL5	CLOSE input activation	
StoP	STOP input activation	
PhoE	PHOT input activation	
PhoP	activation of input for PHOTOCCELL ON OPENING	
PhcL	activation of input for PHOTOCCELL ON CLOSING	
bPr	input activation SAFETY EDGE	
Suc 1	activation of input for MOTOR 1 CLOSING LIMIT SWITCH	
Suo 1	activation of input for MOTOR 1 OPENING LIMIT SWITCH	
Suc 2	activation of input for MOTOR 2 CLOSING LIMIT SWITCH	
Suo 2	activation of input for MOTOR 2 OPENING LIMIT SWITCH	
t iRE	TIMER input activation	
Er 01	photocell test anomaly	check photocell connection and/or parameter/logic settings
Er 02	safety edge test anomaly	check safety edge connection and/or parameter/logic settings
Er 03	photocell on opening test anomaly	check photocell connection and/or parameter/logic settings
Er 04	photocell on closing test anomaly	check photocell connection and/or parameter/logic settings
Er iH *	hardware anomaly	check connections to motor

* H = 0,1,...,9,A,B,C,D,E,F

GENERAL WARNINGS

WARNING! Important safety instructions. Carefully read and comply with the Warnings booklet and Instruction booklet that come with the product as incorrect installation can cause injury to people and animals and damage to property. They contain important information regarding safety, installation, use and maintenance. Keep hold of instructions so that you can attach them to the technical file and keep them handy for future reference.

1) GENERAL SAFETY

WARNING! An incorrect installation or improper use of the product can cause damage to persons, animals or things.

- The units making up the machine and its installation must meet the requirements of the following European Directives: 2004/108/EEC, 2006/95/EEC and later amendments. For all countries outside the EEC, it is advisable to comply with the above-mentioned standards, in addition to any national standards in force, to achieve a good level of safety.
- The Firm disclaims all responsibility resulting from improper use or any use other than that for which the product has been designed, as indicated herein, as well as for failure to apply Good Practice in the construction of entry systems (doors, gates, etc.) and for deformation that could occur during use.
- Make sure the stated temperature range is compatible with the site in which the automated system is due to be installed.
- Do not install the product in an explosive atmosphere.
- Disconnect the electricity supply before performing any work on the system. Also disconnect buffer batteries, if any are connected.
- Have the automated system's mains power supply fitted with a switch or omnipolar thermal-magnetic circuit breaker with a contact separation of at least 3.5 mm.
- Make sure that upline from the mains power supply there is a residual current circuit breaker that trips at 0.03A.
- Make sure the earth system has been installed correctly: earth all the metal parts belonging to the entry system (doors, gates, etc.) and all parts of the system featuring an earth terminal.
- Installation must be carried out using safety devices and controls that meet standard EN 12978.
- Apply all safety devices (photocells, safety edges, etc.) required to keep the area free of crushing, dragging and shearing hazards.
- Only use original spare parts for any maintenance or repair work. The Firm disclaims all responsibility for the correct operation and safety of the automated system if parts from other manufacturers are used.
- Do not make any modifications to the automated system's components unless explicitly authorized by the Firm.
- Dispose of packaging materials (plastic, cardboard, polystyrene, etc.) in accordance with the provisions of the laws in force. Keep nylon bags and polystyrene out of reach of children.
- Anything which is not expressly provided for in the present instructions, is not allowed.
- The device is not meant to be used by people (including children) whose physical, sensory or mental capacities are impaired or who do not have suitable experience or knowledge, unless a person responsible for their safety provides them with supervision or operating instructions.

Warning! For connection to the mains power supply, use a multicore cable with a cross-section of at least 4x1.5mm² of the kind provided for by the regulations mentioned above (by way of example, type H05 VV-F cable can be used with a cross-section of 4x1.5mm²). To connect auxiliary equipment, use wires with a cross-section of at least 0,75 mm².

Have an omnipolar circuit breaker installed with a contact separation of at least 3 mm and featuring overload protection, suitable for cutting the automated device off from the mains.

Only use pushbuttons with a capacity of 10A-250V or more.

The cables must be held in position using an extra fixing device in the proximity of the terminals, e.g. with cable clamps.

Also add more clips to the limit device wires, to the transformer primary or secondary wires, and to the wires connected to the printed circuit. During installation, the power supply cable must be stripped in order for the earthing wire to be connected to the appropriate terminal, but the active wires must be left as short as possible. The earthing wire must be the last to stretch in the case where the cable fixing device becomes loose.

⚠ WARNING: extremely low safety voltage cables must be physically separated from low voltage cables. Access to the electrical compartment or to limit switches must be allowed to skilled personnel only.

⚠ Setting sensitivity incorrectly can result in damage to property and injury to people and animals.

Compliance with current safety rules with regard to people, animals and property must be assured at all times and, more specifically, measures must be taken to avoid risks of injury due to crushing, in the area where the pinion and rack mesh, and any other mechanical hazards. **All critical points must be protected by safety devices in accordance with the provisions of the regulations in force.**

CHECKING THE AUTOMATED DEVICE

Before the automated device is finally put into operation, perform the following checks meticulously:

- Make sure all components are fastened securely.
- Check the correct functioning of all safety devices (limit microswitches, photocells, sensitive edges etc.).
- Make sure that the anti-crush system stops the door within the limits provided for by the standards in force.
- Check the emergency operation control device.
- Check the opening and closing operations with the control devices in use.
- Check the standard and customised electronic functioning logic.

MAINTENANCE

- Dismantle the gearmotor and replace the lubricating grease every two years.
- When any operational malfunction is found, and not resolved, disconnect the mains power supply and request the assistance of a specialised technician (installer).

SCRAPPING

Materials must be disposed of in conformity with the current regulations. In case of scrapping, the automation devices do not entail any particular risks or danger. In case of recovered materials, these should be sorted out by type (electrical components, copper, aluminium, plastic etc.).

DISMANTLING

When the automation system is disassembled to be reassembled on another site, proceed as follows:

- Disconnect the power supply and the entire electrical installation.
- Remove the actuator from its fixing base.
- Disassemble all the installation components.
- In the case where some of the components cannot be removed or are damaged, they must be replaced.

Correct controller operation is only ensured when the data contained in the present manual are observed. The Company is not to be held responsible for any damage resulting from failure to observe the installation standards and the instructions contained in the present manual. The descriptions and illustrations contained in the present manual are not binding. The Company reserves the right to make any alterations deemed appropriate for the technical, manufacturing and commercial improvement of the product, while leaving the essential product features unchanged, at any time and without undertaking to update the present publication.

1) FOREWORD

The **RIGEL 5** control unit is supplied by the manufacturer with standard setting. Any modifications must be entered using the universal palmtop programmer or the incorporated display. This Control unit supports the entire EELINK protocol.

These are its main features:

- Control of one or two motors up to 600W power.
- Electronic torque setting.
- Adjustable electrodynamic braking.
- End-of-run speed slow-down.
- Separate opening / closing limit-switch inputs for each motor.
- Output for zone light.
- Separate inputs for safety devices.
- 12V output for click or suction-type electric lock.
- Output for timer piloting.
- Clock input.
- Connector for traffic-light board / motor preheating.
- Incorporated radio receiver.

The board is provided with a removable terminal board for easier maintenance and replacement. This is supplied with a series of prewired jumpers to make work easy for the installer.

The jumpers relate to the following terminals: 33-34, 35-36, 36-37, 38-39, 39-40, 41-42, 42-43, 52-55. If the above terminals are used, remove the respective jumpers.

2) TECHNICAL SPECIFICATIONS

CONTROL UNIT	
Power supply	230V±10% 50Hz*
Mains/low voltage insulation	> 2MΩ 500V $\overline{\text{---}}$
Dielectric strength	mains/bty 3750V~ for 1 minute
Motor output current	1A+1A max (230V~) - 2A+2A max (110V~)
Motor relay commutation current	10A
Zone/courtesy light	max 150W
Supply to accessories	24V~ (1A max absorption)
Electric lock	12V $\overline{\text{---}}$ (0.5A max, 2A for 3 s)
Light/alarm output with free n.o. contact	max 3A 250V~
Gate-open warning light	24V~ 3W max
Blinker	230V 40W max
Fuses	See Fig. A
Dimensions	See Fig. B
RECEIVER	
Commands association	1st ch. = start 2nd ch. = relay 2nd ch. for 1 sec.
Built-in Rolling-Code radio-receiver	frequency 433.92MHz
N° of combinations	4 billion
Max. n° of remotes that can be memorized	63
Antenna impedance	50 Ohm (RG58)

(*) Special supply voltages to order.

Usable transmitter versions:

All ROLLING CODE transmitters compatible with



3) TUBE ARRANGEMENT Fig.A

Install the electrical system referring to the standards in force for electrical systems CEI 64-8, IEC 364, harmonization document HD 384 and other national standards.

4) TERMINAL BOARD WIRING Fig. A

Once suitable electric cables have been run through the raceways and the automated device's various components have been fastened at the pre-determined points, the next step is to connect them as directed and illustrated in the diagrams contained in the relevant instruction manuals. Connect the live, neutral and earth wire (compulsory). The mains cable must be clamped in the relevant cable gland, and the accessories' wires in the cable gland, while the earth wire with the yellow/green-coloured sheath must be connected in the relevant terminal.

TERMINAL	DESCRIPTION
1	GND terminal
2-3	230V~±10%, 50-60Hz power supply (2 neutral, 3 phase).
4-5-6	Motor connection 1 (delayed opening), terminals 5-6 for motor drive, terminal 4 common.
5-14	Motor capacitor connection 1
7-8-9	Motor connection 2 (delayed closing), terminals 8-9 for motor drive, terminal 7 common. N.B. If only one motor is used, use motor output 2 and configure logic "1 active motor".
8-15	Motor capacitor connection 2.
10-11	230V~ output for blinker light (40W max) and EBP 230V molelectric lock. WARNING! If the SSR5 auxiliary board is used for motor preheating, move the connection to terminals 12-13 (Fig. A) and refer to LOGIC TABLE "B" (Blinker output).
12-13	230V~ output for zone lighting (courtesy light dipswitch ON, flashing light output dipswitch OFF)
	230V~ output for courtesy light (courtesy light dipswitch OFF, flashing light output dipswitch OFF)
	230V~ output for flashing light output (flashing light dipswitch ON)
16-17	Stair-light output (N.O.) (dip Light/alarm = OFF) Only connect these terminals to safety extra low voltage (SELV) circuits suitably insulated from live parts.
	Light/alarm output (N.O.) (dip Light/alarm = ON). Only connect these terminals to safety extra low voltage (SELV) circuits suitably insulated from live parts.
18-19	N.O. output for 2nd radio channel (SCA dipswitch - 2ch = OFF)
	N.O. output for gate open warning light. This warning light is off when the gate is closed, flashes as it is closing and remains on when the gate is open or opening. (dipswitch SCA - 2ch = ON)
20-21	24V~ output (1A max.) to power accessories.
20-44	24V~ output to power VSAFE
22-23	12V $\overline{\text{---}}$ solenoid latch output (lock type dipswitch = OFF)
	12V $\overline{\text{---}}$ solenoid sucker output (lock type dipswitch = ON)
24-25	Antenna input for radio receiver board (24 signal, 25 braid).
26-27	INTERNAL START Pushbutton (N.O.). Internal Start command for traffic light.
27-28	START Pushbutton (N.O.). Parallel to radio receiver relay (CH1). External Start command for traffic light.
27-29	PEDESTRIAN pushbutton (N.O.). Activation takes place on motor 2; moreover, if the opening cycle has started (not from pedestrian pushbutton), the pedestrian control has the same effect as a Start command.
30-31	OPEN Pushbutton (N.O.).
30-32	CLOSE Pushbutton (N.O.).
33-34	LOCK pushbutton (N.C.). If not used, leave the jumper connected.
35-36	Photocell contact input PHOT (n.c.). If not used, leave jumpers inserted.
36-37	Photocell contact input PHOT OPENING (N.C.). If not used, leave jumpers inserted. (dipswitch BAR = OFF)
	BAR safety edge input (n.c.) If intervenes during opening, it stops and we have partial closure. If not used, leave jumpers inserted. (dipswitch BAR = ON)
38-39	Opening limit switch for motor 1 SWO1 (N.C.). If not used, leave the jumper connected.
39-40	Closing limit switch for motor 1 SWC1 (n.c.). If not used, leave the jumper connected.
41-42	Opening limit switch for motor 2 SWO2 (n.c.). If not used, leave the jumper connected.
42-43	Closing limit switch for motor 2 SWC2 (n.c.). If not used, leave the jumper connected.
20-44	24V output for transmitters.
45-46-47	Connection with tested safety devices (see Fig. D)
48-49-50	Connection with tested safety devices (see Fig. D)

51-52	Clock input (N.O.). If the connected contact is open (N.O.), the leaves close and get ready for normal operation. If the contact is closed (N.C.), the leaves open and stay open until the contact reopens. If the opening movement controlled by the TIMER is prevented by the safety devices, gate opening can be resumed by activating the START/OPEN control.
52-55	Input for photocell edge contact on closing SAFE CL (N.C.). In case of activation during closing, the gate is stopped and partly reopened. If not used, leave the jumper connected.
53	Photocell test input (PHOT-FAULT).
54	Safety edge/opening photocell test input (BAR-FAULT).
56	Closing photocell test input (PHOT CL-FAULT).
JP7	Radio receiver board connector.
JP8	Optional card connector (SCS)
JP9	Traffic-light / Preheating SSR5 board connector.

5) CONNECTION WITH EXPANSION BOARDS AND UNIVERSAL HANDHELD PROGRAMMER (Fig. A)

Refer to specific manual.

6) SAFETY DEVICES

NOTE: ONLY USE RECEIVING SAFETY DEVICES WITH FREE CHANGE-OVER CONTACT.

6.1) TESTED DEVICES (FIG. D)

6.2) NON-TESTED DEVICES (FIG. C - D)

7) CALLING UP MENUS: FIG. 1

7.1) PARAMETERS MENU (PARAMETERS TABLE "A")

7.2) LOGIC MENU (LOGIC TABLE "B")

7.3) RADIO MENU (RADIO TABLE "C")

- IMPORTANT NOTE: THE FIRST TRANSMITTER MEMORIZED MUST BE IDENTIFIED BY ATTACHING THE KEY LABEL (MASTER).

In the event of manual programming, the first transmitter assigns the RECEIVER'S KEY CODE: this code is required to subsequently clone the radio transmitters.

The Clonix built-in on-board receiver also has a number of important advanced features:

- Cloning of master transmitter (rolling code or fixed code).
- Cloning to replace transmitters already entered in receiver.
- Transmitter database management.
- Receiver community management.

To use these advanced features, refer to the universal handheld programmer's instructions and to the general receiver programming guide.

7.4) LANGUAGE MENU (LANGUAGE)

Used to set the programmer's language on the display.

7.5) DEFAULT MENU (DEFAULT)

Restores the controller's DEFAULT factory settings.

8) SCS OPTIONAL MODULES

8.1) SERIAL CONNECTION USING SCS1 BOARD (Fig. A - E)

The **RIGEL 5** control panel allows several automation units (SCS1) to be connected in a centralised way by means of appropriate serial inputs and outputs. This makes it possible to use one single command to open and close all the automation units connected.

Following the diagram in Fig. E, proceed to connecting all the **RIGEL 5** control panels, exclusively using a telephone-type line.

Should a telephone cable with more than one pair be needed, it is indispensable to use wires from the same pair.

The length of the telephone cable between one appliance and the next must not exceed 250 m.

At this point, each of the **RIGEL 5** control panels must be appropriately configured, by setting a MASTER unit first of all, which will have control over all the others, to be necessarily set as SLAVE (see logic menu).

Also set the Zone number (see parameter menu) between 0 and 127.

The zone number allows you to create groups of automation units, each one answering to the Zone Master unit. **Each zone can only be assigned one Master unit, the Master unit in zone 0 also controls the Slave units in the other zones.**

8.2) Interface with WIEGAND systems via SCS-WIE module.

Refer to the SCS-WIE module's instructions.

9) SSR5 TRAFFIC-LIGHT / MOTOR PREHEATING BOARD

When inserted in the appropriate connector, it provides:

- Control of two traffic lights with 2 lights each.
- Preheating of motors for cold climate.

Refer to specific manual.

9.1) Traffic light layout

Traffic light 1 must be positioned on the outside of the gate and traffic light 2 on the inside.

WARNINGS - Place signs for speed limitation to "Walking pace".

9.2) Motor preheating layout

The "S" probe must be positioned and fixed on the outside to detect external temperature. It is to be connected to respective terminals 7-8 on the preheating board.

WARNINGS - Move the EBP solenoid lock and flashing light to 12-13. (Fig. A Ref. 2)

WARNINGS - Set flashing light dipswitch = ON

INSTALLATION MANUAL

D811472 00100_01

10.1) TABLE A: PARAMETERS MENU (PArRn)

Parameter	min.	max.	default	personal	Definition	Description
tca	3 sec.	120 sec.	40		Automatic Closing Time	Set the numerical value of the TCA automatic closing time from 3 to 120 seconds.
work. t. n ot.1	3 sec.	180 sec.	60		Operation time motor 1	Enter the numerical value corresponding to the working time from 3 to 180 seconds for motor 1.
work. t. n ot.2	3 sec.	180 sec.	60		Operation time motor 2	Enter the numerical value corresponding to the working time from 3 to 180 seconds for motor 2.
PEd. t.	3 sec.	9 sec.	6		Pedestrian operation time	Set the pedestrian opening time of motor 2 from 3 to 90 seconds.
oPEN dELAY t INE	0 sec.	10 sec.	3		Opening delay time for leaf 1	Set the opening delay time for motor 1 with respect to motor 2, which can be adjusted from 0 to 10 seconds.
CL5 dELAY t INE	0 sec.	60 sec.	3		Closing delay time for leaf 2	Set the closing delay time for motor 2, which can be adjusted from 0 to 60 seconds.
SLow - down t.	0 sec.	20 sec.	0		Slow-down time	Set the slow-down to approach time from 0 to 20 seconds. The slow-down time is subtracted from the work time. NOTE: it is advised to activate timing. NOTE: only use this function when limit switches are fitted. NOTE: Do not use with hydraulic motors.
CLERr. t	0 sec.	30 sec.	15		Traffic-light area clearance time	Set the required clearance time for the area involved in the traffic governed by traffic light, from 0 to 30 seconds. Set to 0 if not used.
PrEHrEt.	0%	99%	30%		Preheating	Set the percentage value of the current from 0 (deactivated pre-heating) to 99% which can be made to pass through the motor windings to keep them at the right temperature. NOTE: Only with SSR5.
SLowd torQUE	1%	99%	50%		Slowdown Motor Torque	Set numerically from 1% to 99% the value of motor torque during slowdown time.
Mot. torQUE	1%	99%	50%		Motor torque	Set the numerical torque value from 1 to 99%. NOTE: When using with oil-hydraulic motors, it is necessary to set the torque value to 99% and adjust the force directly on the motor.
brAKE	0%	99%	0%		Braking	Set the braking value from 0% (min.) to 99% (max.) according to the gate weight and the mechanical demands involved.
EMEr. brAKE	0%	99%	60%		Emergency braking	Set the value of the emergency braking from 0% (min.) to 99% (max.). This is carried out by enabling the safety commands on the inputs 34 (block), 37 (SAFE OP) and 55 (SAFE CL).
ZonE	0	127	0		Zona	Enter the zone number between 0 (minimum value) and 127 (maximum value). See paragraph "SCS OPTIONAL MODULES".

10.2) TABLE B: LOGIC MENU (LoG ic)

Logic	Default	Definition	Cross out setting used	Description
tca	OFF	Automatic Closing Time	ON	Switches automatic closing on.
			OFF	Switches automatic closing off.
ibl oPEN	OFF	Opening Impulse lock	ON	The Start impulse has no effect during the opening phase.
			OFF	The Start impulse becomes effective during the opening phase.
ibl tca	OFF	Impulse lock TCA	ON	The Start impulse has no effect during the TCA dwell period.
			OFF	The Start impulse becomes effective during the TCA dwell period.
bl CLoSE	OFF	Impulse lock on closing	ON	The start impulse has no effect during the closing stage.
			OFF	The start impulse is effective during the closing stage.
rRn bLoU cOP	OFF	Ram blow on opening	ON	It pushes for approx. 2 seconds in closing direction before opening. This allows the electric lock to be released more easily (not affected by limit switches). IMPORTANT - When no adequate mechanical backstops are installed, do not use this function. It is also to be absolutely avoided in the automation of sliding gates.
			OFF	Excludes the ram blow in closing.
rRn bLoU cCL	OFF	Ram blow in closing	ON	Before carrying out the closing manoeuvre, the gate pushes for about 2 seconds on opening. This allows the electric lock to be released more easily.(not affected by limit switches) IMPORTANT - When no adequate mechanical backstops are installed, do not use this function. It is also to be absolutely avoided in the automation of sliding gates.
			OFF	Excludes the ram blow in closing.
2 StEP	OFF	2-step, 4-step logic	ON	Enables 2-step logic (prevails over "3-step logic").
			OFF	Enables 4-step logic when the 3-step logic is set to OFF.
3 StEP	OFF	3-step logic	ON	Enables 3-step logic (with 2 steps=OFF).
			OFF	Disables 3-step logic.
PrE-ALArn	OFF	Pre alarm	ON	The blinker comes on about 3 seconds before the motor starts.
			OFF	The blinker comes on at the same time as the motor starts.
bLoc PEr5 ISt	OFF	Lock hold	ON	If the motors remain still in a totally open or closed position for over one hour, they are activated for about 3 seconds in the respective direction. This operation takes place once every hour. N.B.: This function has the purpose of compensating any oil volume decrease in the hydraulic motors, due to a temperature drop during prolonged pauses, for instance at night, or to internal leaks. IMPORTANT - When no adequate mechanical backstops are installed, do not use this function. It is also to be absolutely avoided in the automation of sliding gates.
			OFF	Exclude block maintenance.
hold -to- run	OFF	Hold-to-run	ON	Hold-to-run operation: the manoeuvre continues as long as the command key is kept pressed. IMPORTANT - It is not possible to use the radio transmitter.
			OFF	Impulse operation.

A start impulse has the following effects:

	2 step	3 step	4 step
closed	opens	opens	opens
on closing			stop
open	closes	closes	closes
on opening		stop + TCA	stop + TCA
after stopping	closes	opens	opens

INSTALLATION MANUAL

<i>Photo. oPEn</i>	OFF	Photocells on opening	ON	In case of obscuring, this excludes photocell operation on opening. During the closing phase, it immediately reverses the motion.
			OFF	In case of obscuring, the photocells are active both on opening and on closing. When a photocell is obscured on closing, it reverses the motion only after the photocell is disengaged.
<i>FRSt cLS</i>	OFF	Rapid closing	ON	Closes the gate after photocell disengagement, before waiting for the end of the TCA (automatic closing time) set.
			OFF	Command not entered.
<i>tEst Phot</i>	OFF	Photocell test	ON	Activates photocell check (see Fig. D)
			OFF	Deactivates photocell check
<i>tEst bAr</i>	OFF	Electric edge test	ON	Activates electric edge check (see Fig. D)
			OFF	Deactivates electric edge check
<i>tEst Phot oP.</i>	OFF	Photocell test on opening	ON	Enables the test of the active photocells on opening.
			OFF	Disables the test of the active photocells on opening.
<i>tEst Phot cL.</i>	OFF	Photocell test on closing	ON	Enables the test of the active photocells on closing.
			OFF	Disables the test of the active photocells on closing.
<i>FRStEr</i>	OFF	Master/Slave	ON	The control panel is set as Master in a centralised connection (see "SCS OPTIONAL MODULES").
			OFF	The control panel is set as Slave in a centralised connection (see "SCS OPTIONAL MODULES").
<i>FiHEd codE</i>	OFF	Fixed code	ON	The receiver is configured for operation in fixed-code mode.
			OFF	The receiver is configured for operation in rolling-code mode.
<i>rRd io Prog</i>	ON	Radio transmitter programming	ON	This enables transmitter storage via radio: 1 – First press the hidden key (P1) and then the normal key (T1, T2, T3 or T4) of a transmitter already memorised in standard mode by means of the radio menu. 2 – Within 10s press the hidden key (P1) and the normal key (T1, T2, T3 or T4) of a transmitter to be memorised. The receiver exits the programming mode after 10s, other new transmitters can be entered before the end of this time. This mode does not require access to the control panel.
			OFF	This disables transmitter storage via radio. The transmitters can only be memorised using the appropriate Radio menu. Clones and replays are not accepted.
<i>t INE. c.</i>	OFF	Time count	ON	The control unit calculates the activation time of each motor, based on the preceding manoeuvres.
			OFF	The control unit activates the motors at each manoeuvre for the time set. N.B. Always set the operation time to a slightly higher value than needed to carry out the complete manoeuvre.
<i>ZonE LIGHt</i>	OFF	Courtesy light	ON	Zone light. Remains active as long as the manoeuvre lasts.
			OFF	Courtesy light. Remains active for 90 seconds after last operation. N.B. These settings cannot be used if the blinker output is set to ON.
<i>cLoCK PEd</i>	OFF	Clock / Pedestrian	ON	Input for the connection of an external timer. The Clock input is only active in Motor 2, for the pedestrian time set. A start command given during the clock phase carries out complete gate opening and closing, resetting the open pedestrian position.
			OFF	The Clock input acts on both motors.
<i>LIGHt-ALARm</i>	ON	Light/Alarm	ON	Gate-open alarm output (activated if the gate remains open for twice the TCA time set).
			OFF	Stair-light control (the impulse stays on for 1 second).
<i>i Mot. on</i>	OFF	1 active motor	ON	Only motor 2 activated (1 leaf).
			OFF	Both motors are activated (2 leaves).
<i>ScR-2ch</i>	OFF	Gate-opener 2nd radio channel warning light	ON	The output between terminals 18 and 19 is configured as Gate-open warning light, in this case the 2nd radio channel controls pedestrian opening.
			OFF	The output between terminals 18 and 19 is configured as 2nd radio channel.
<i>bAr</i>	ON	Safety edge	ON	Input of terminals 36-37 is active as input for the safety edge.
			OFF	Input of terminals 36-37 is active as input for opening photocells.
<i>bL InH</i>	OFF	Blinking output	ON	Set the output at terminals 12-13 ("courtesy light") as blinking output (active only during leaf movement). N.B. Any setting relating to the "courtesy light" function is ignored.
			OFF	Keep the output at terminals 12-13 as "courtesy light" or "zone light". WARNING! It is not possible to use the SSR5 board in motor preheating mode and at the same time have the Zone light/Courtesy Light and Blinker/Electric lock on. In this case, outputs 10-11 cannot be used and outputs 12-13 can only be used for one of the two functions.
<i>SUct ion-tyPE</i>	OFF	Type of lock	ON	Suction-type lock. Enabled with gate closed.
			OFF	Click lock. Enabled with a pulse at each opening.

10.3) TABLE C: RADIO MENU (*rRd io*)

Logic	Description
<i>Add StARt</i>	Add Start Key associates the desired key with the Start command.
<i>Add 2ch</i>	Add 2ch Key associates the desired key with the 2nd radio channel command.
<i>ErASE bY</i>	Erase List WARNING! Erases all memorized remote controls from the receiver's memory.
<i>cod rH</i>	Read receiver code Displays receiver code required for cloning remote controls.
<i>Wk</i>	ON = Enables remote programming of cards via a previously memorized W LINK transmitter. It remains enabled for 3 minutes from the time the W LINK remote control is last pressed. OFF = W LINK programming disabled.

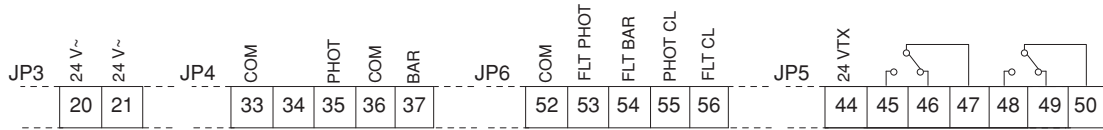

FOTOCPELLULE, PHOTOCELLS, FOTOCPELLULES, FOTAZELLEN, FOTOCÉLULAS, FOTOCELLEN

COSTE / FOTOCPELLULE IN APERTURA, COSTE / FOTOCPELLULE IN APERTURA, COSTE / FOTOCPELLULE IN APERTURA, COSTE / FOTOCPELLULE IN APERTURA, COSTE / FOTOCPELLULE IN APERTURA.

FOTOCPELLULE IN CHIUSURA, PHOTOCELLS, FOTOCPELLULES, FOTAZELLEN, FOTOCÉLULAS, FOTOCELLEN

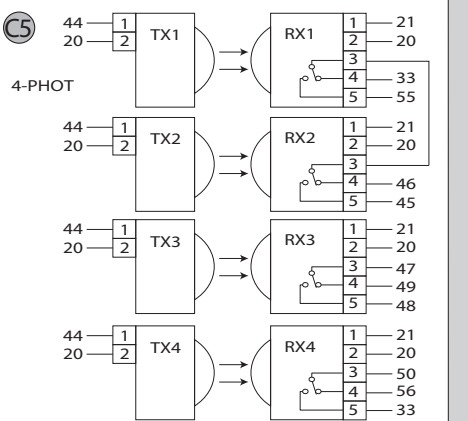
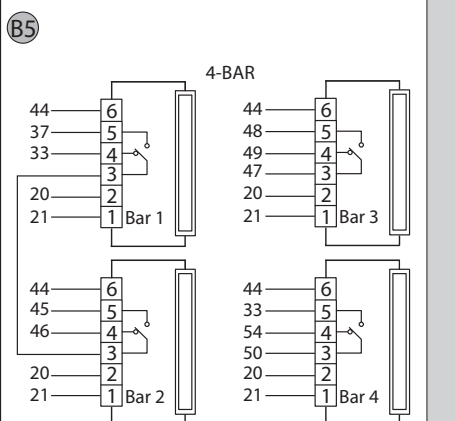
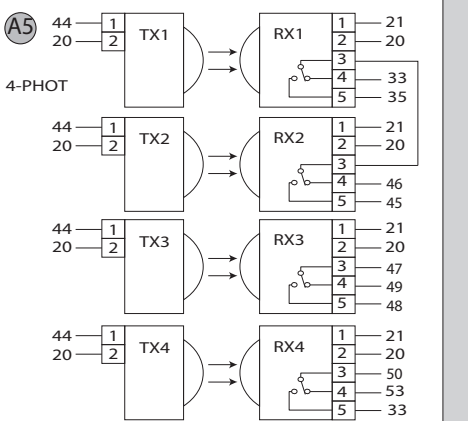
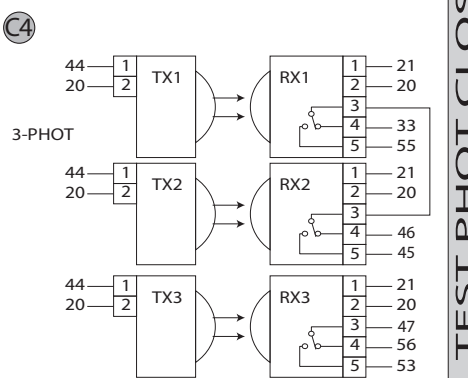
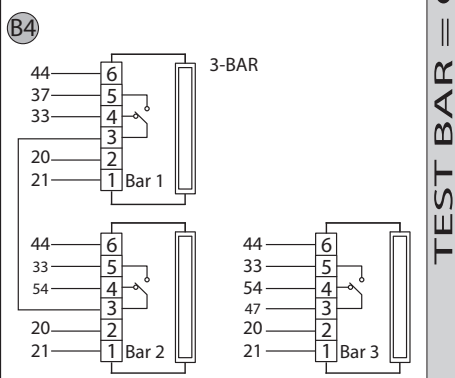
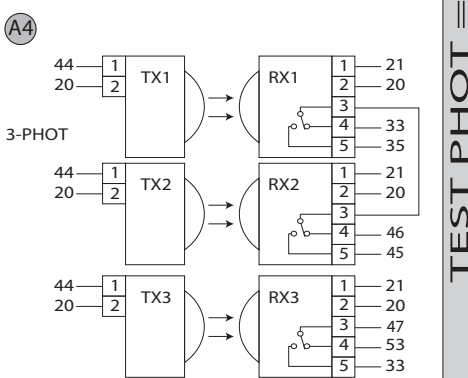
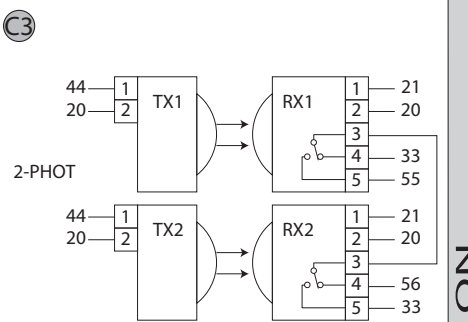
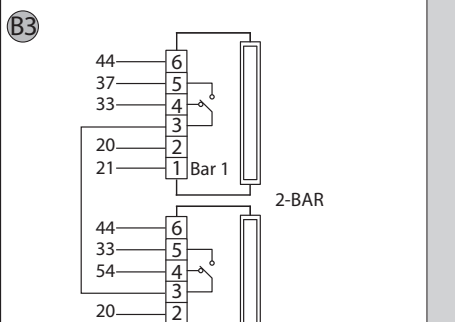
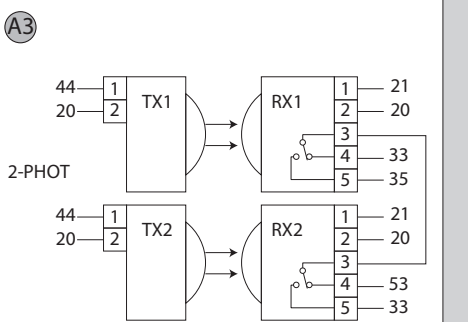
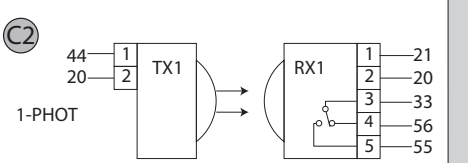
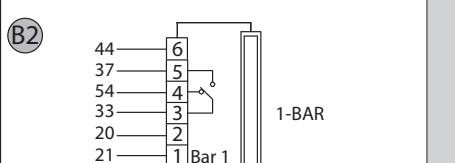
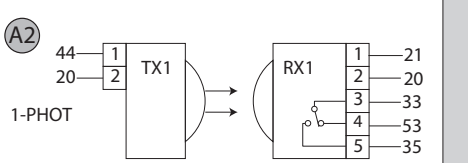
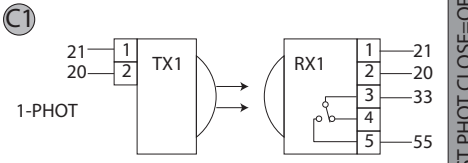
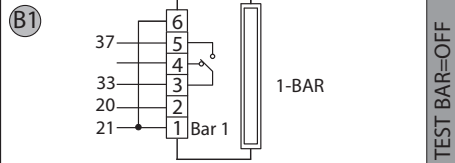
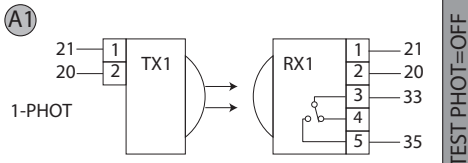

TEST PHOT=OFF

TEST BAR=OFF

TEST PHOT CLOSE=OFF

TEST PHOT = ON

TEST BAR = ON

TEST PHOT CLOSE = ON

Combinazioni non possibili, Not possible combinations, Combinaisons non possibles, Nicht mögliche kombinationen, Combinaciones no posibles, Combinaties niet mogelijk.

D1

Fotocellule, Photocells, Photocellules, Fotocellen.	Coste / Fotocellule in Apertura, Coste / Fotocellule in Apertura, Coste / Fotocellule in Apertura, Coste / Fotocellule in Apertura,	Fotocellule in Chiusura, Fotocellule in Chiusura, Fotocellule in Chiusura, Fotocellule in Chiusura.
A1	B4	C5
A1	B5	C4, C5
A2	B4	C5
A2	B5	C4, C5
A3	B4	C5
A3	B5	C4, C5
A4	B1	C5
A4	B2	C5
A4	B3	C5
A4	B4	C4, C5
A4	B5	C1, C2, C3, C4, C5
A5	B1	C4, C5
A5	B2	C4, C5
A5	B3	C4, C5
A5	B4	C1, C2, C3, C4, C5
A5	B5	C1, C2, C3, C4, C5

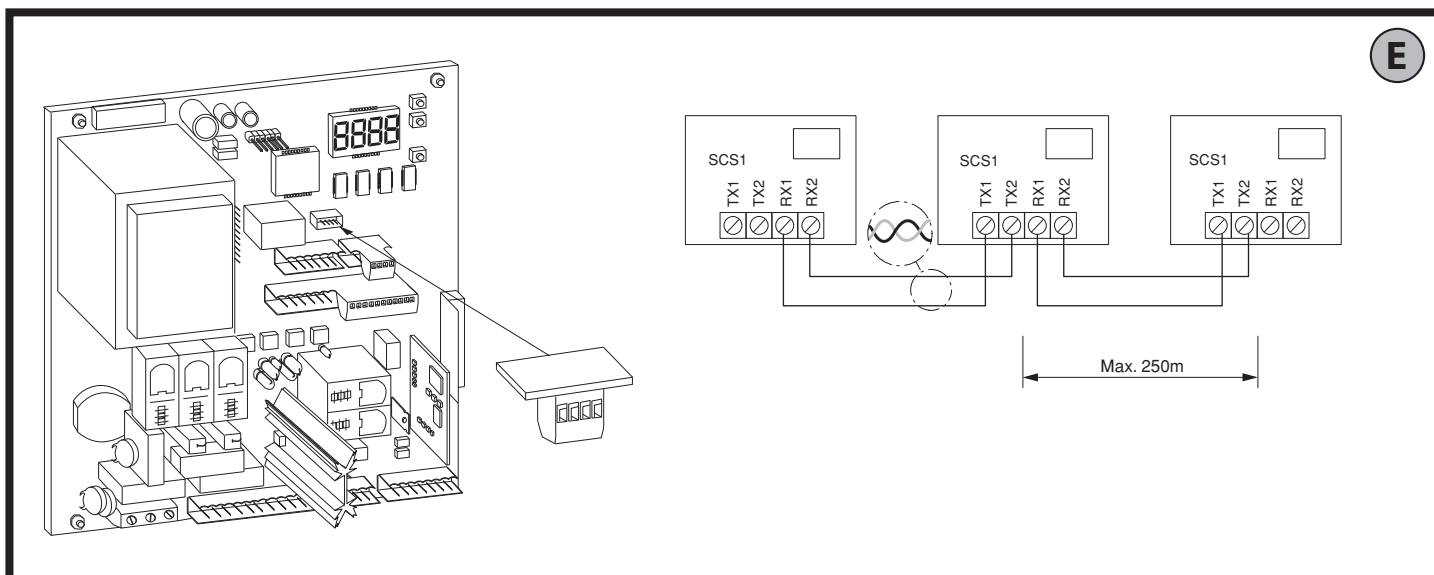

E

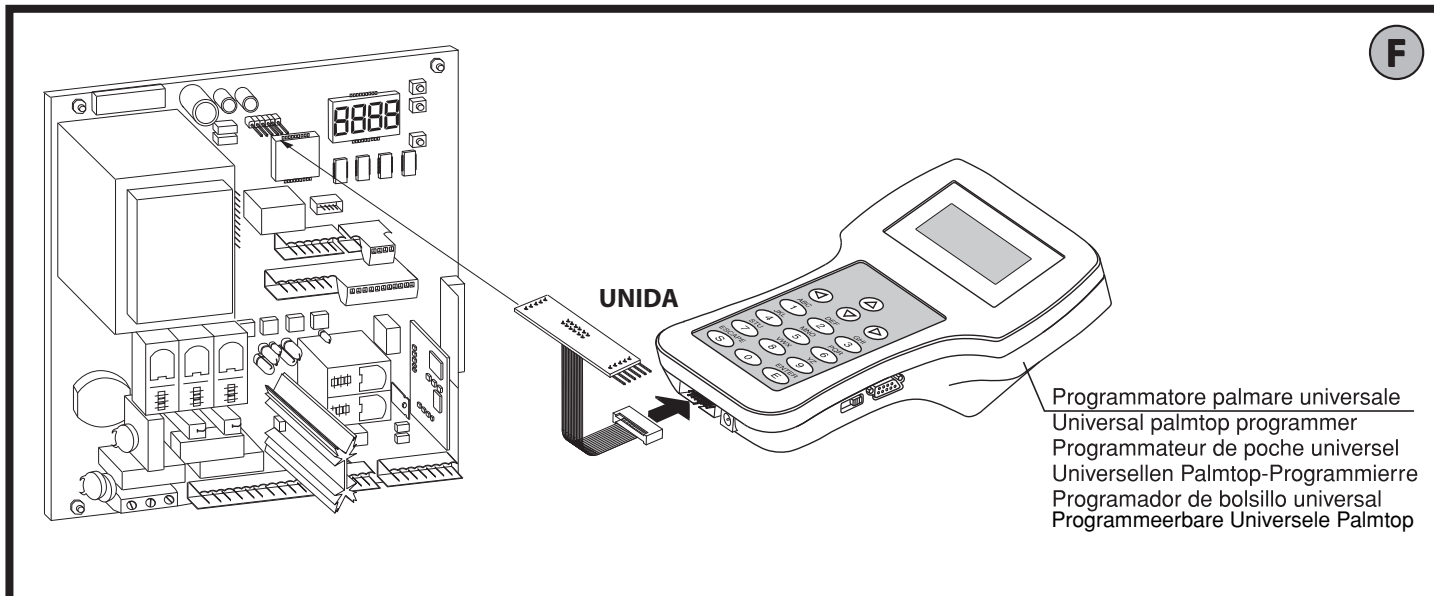

F