

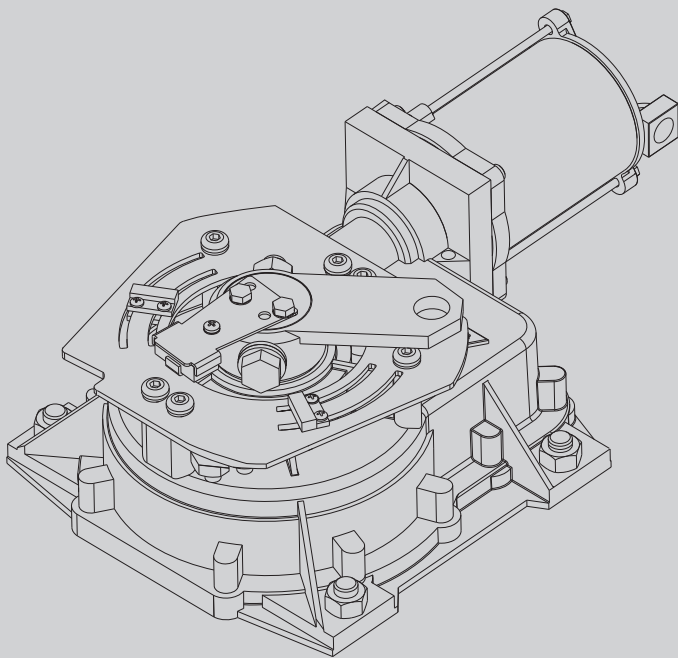

D811479\_06 15-04-15

AUTOMAZIONE ELETTROMECCANICA INTERRATA PER CANCELLI A BATTENTE  
ELECTROMECHANIC AUTOMATIONS FOR SWING GATES  
AUTOMATISME ELECTROMECHANIQUE ENTERRÉ POUR PORTAILS A VANTAUX  
ELEKTROMECHANISCHER ANTRIEB FÜR FLÜGELGITTERTORE  
AUTOMATISMO ELECTROMECHANICO SOTERRADO PARA CANCELAS BATIENTES  
AUTOMATIZAÇÃO ELECTROMECHANICA SUBTERRNEA PARA PORTÕES COM BATENTE



ISTRUZIONI DI INSTALLAZIONE  
INSTALLATION MANUAL  
INSTRUCTIONS D'INSTALLATION  
MONTAGEANLEITUNG  
INSTRUCCIONES DE INSTALACION  
INSTALLATIEVOORSCHRIFTEN

# ELI 250 BT



AZIENDA CON SISTEMA DI GESTIONE  
INTEGRATO CERTIFICATO DA DNV  
= UNI EN ISO 9001:2008 =  
UNI EN ISO 14001:2004

**Attenzione!** Leggere attentamente le "Avvertenze" all'interno! **Caution!** Read "Warnings" inside carefully! **Attention!** Veuillez lire attentivement les Avertissements qui se trouvent à l'intérieur!  
**Achtung!** Bitte lesen Sie aufmerksam die „Hinweise“ im Inneren! **¡Atención!** Leer atentamente las "Advertencias" en el interior! **Let op!** Lees de "Waarschuwingen" aan de binnenkant zorgvuldig!

Fig. 1

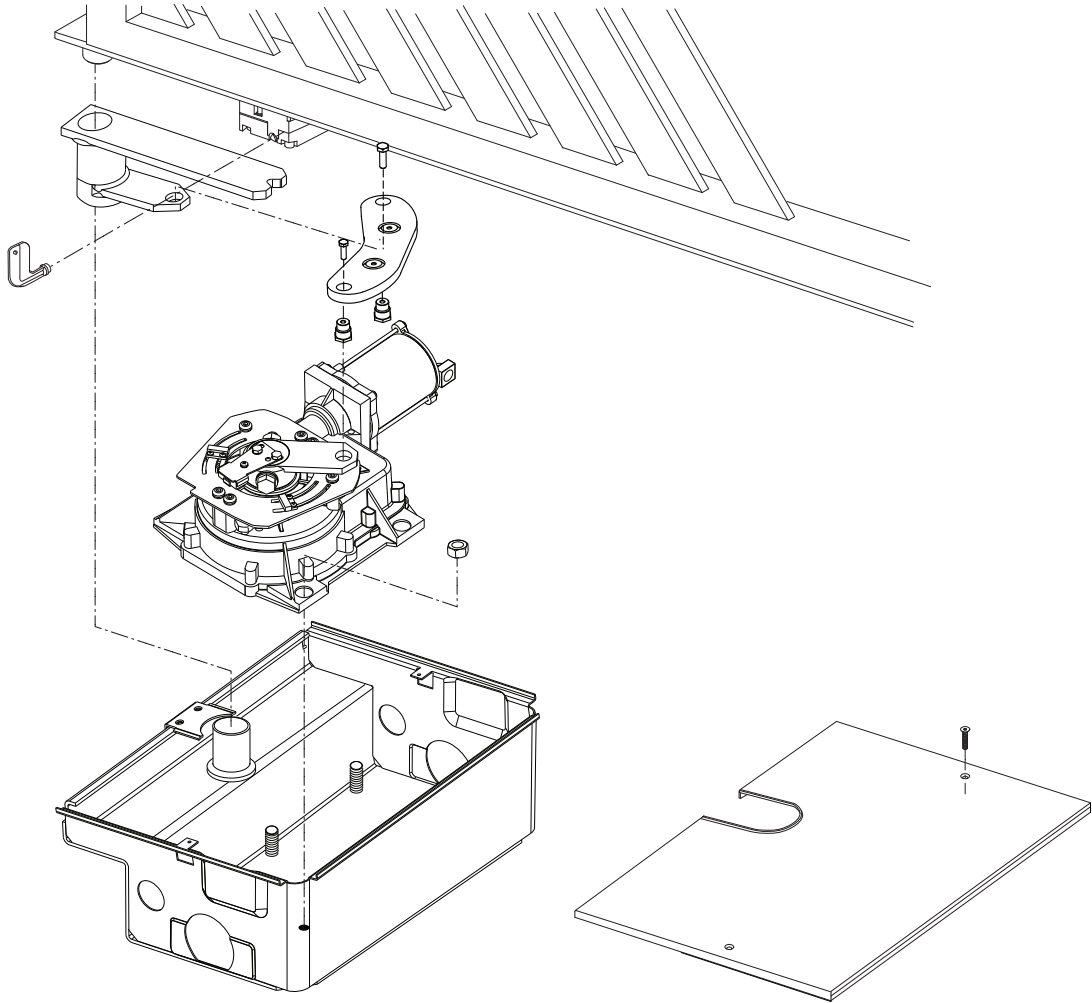

D811479\_06

Fig. 2

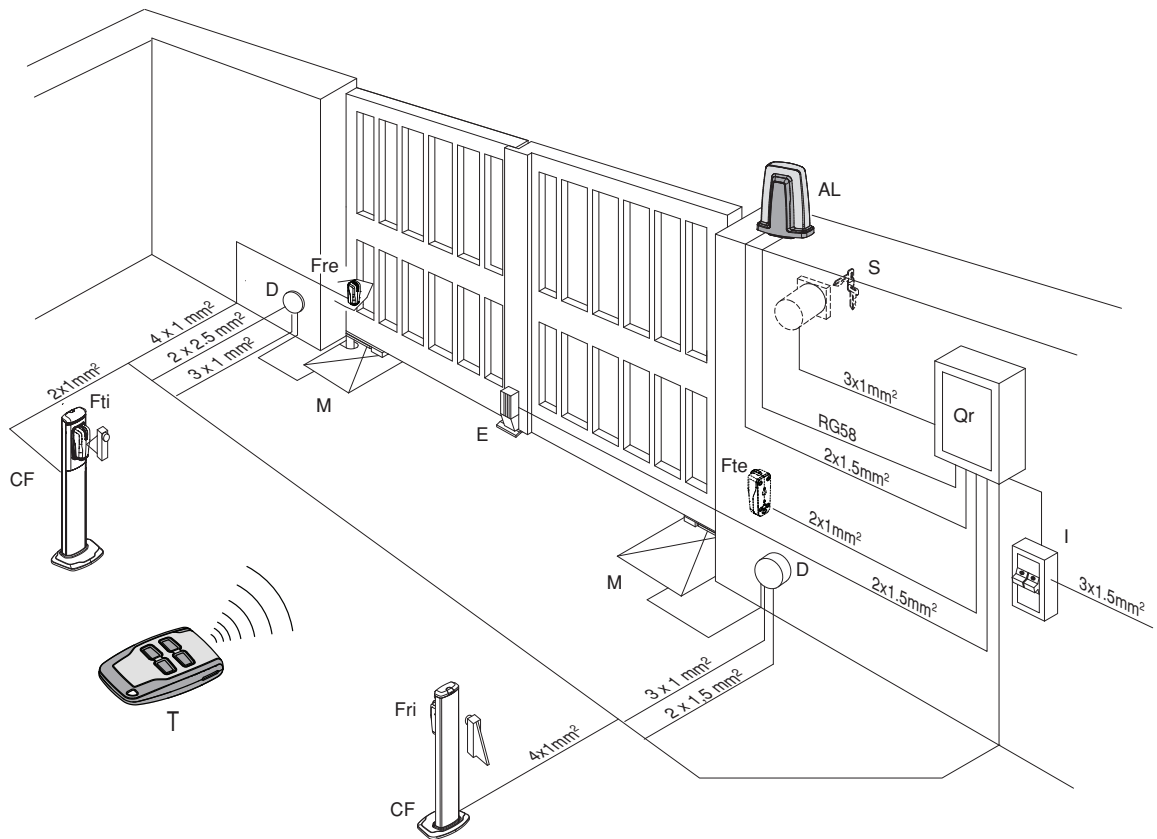

Fig. 3

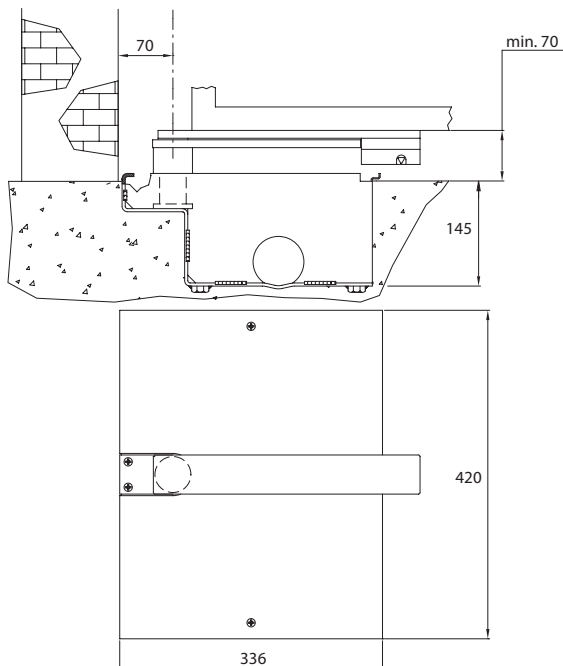

Fig. 4

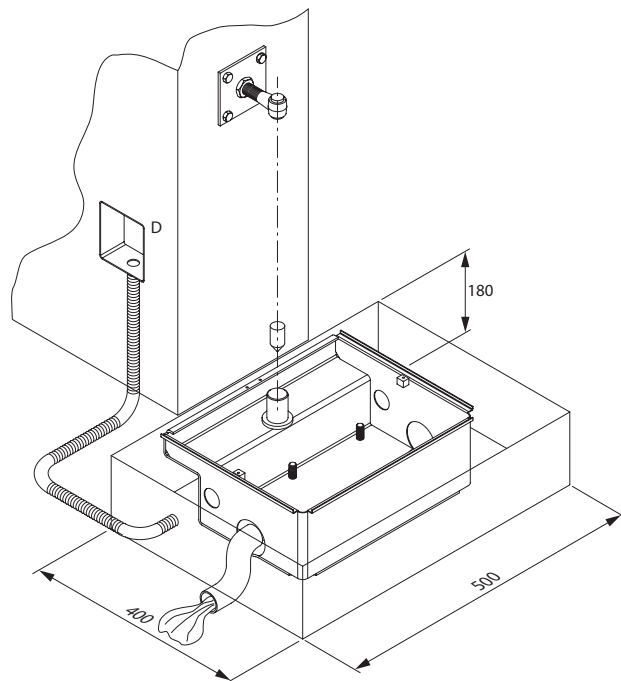

Fig. 5

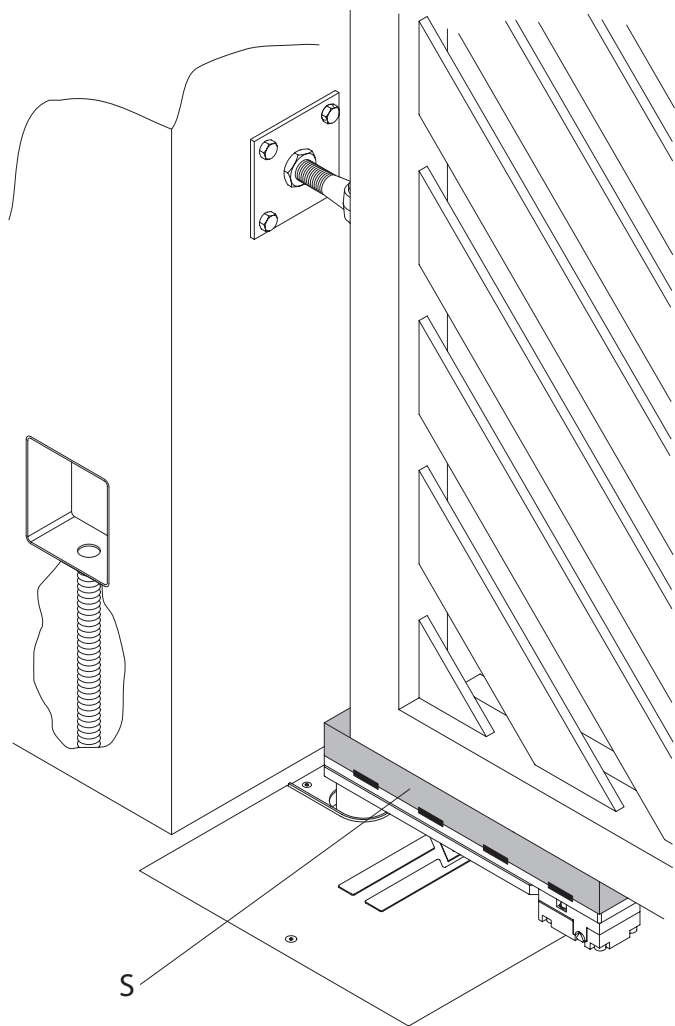
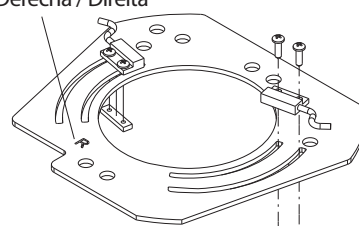

Fig. 6

Destra / Right  
Droite / Rechts  
Derecha / Direita

A



Sinistra / Left  
Gauche / Links  
Izquierda / Esquerda

M8

B

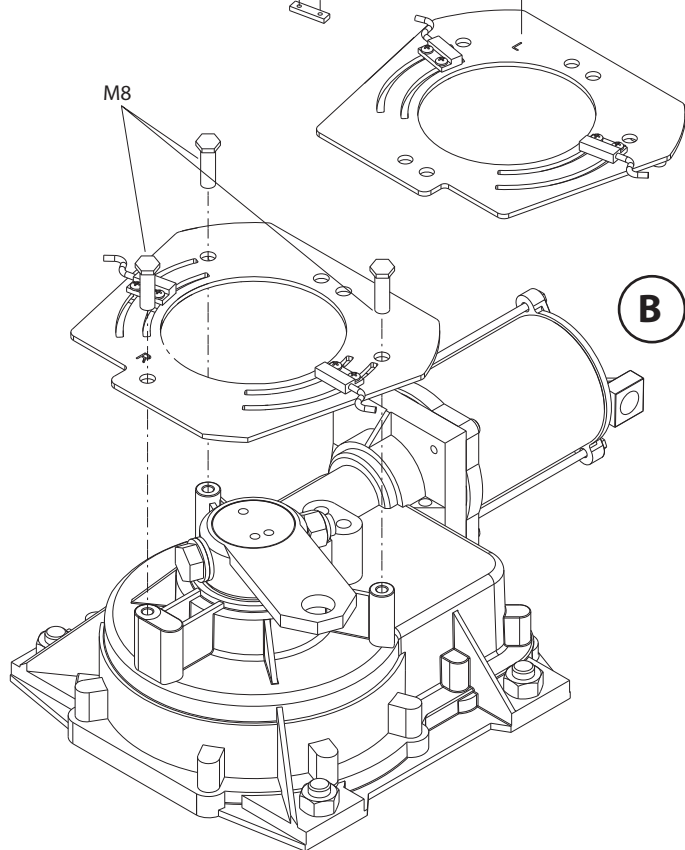
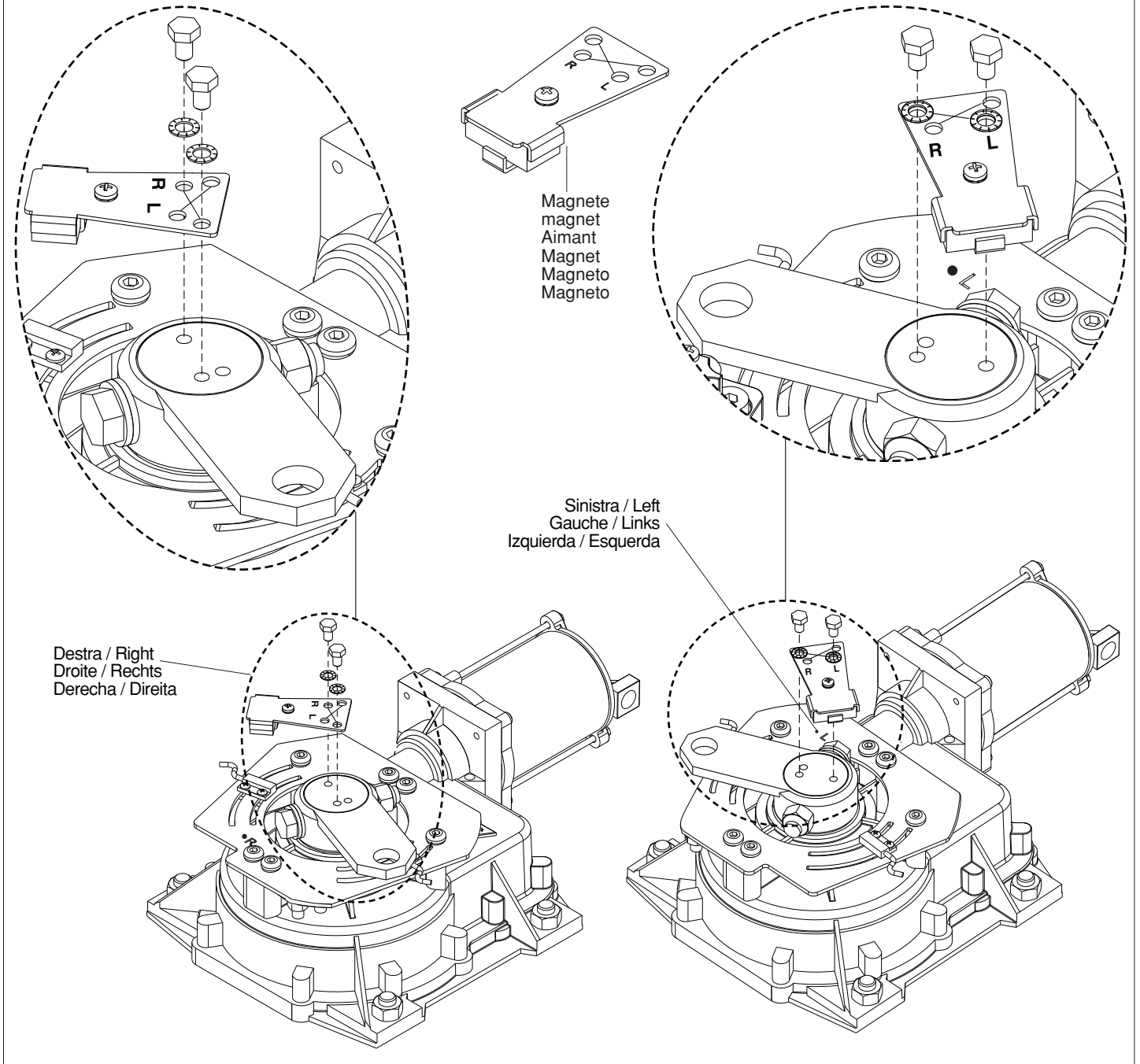

Fig. 7



D811479\_06

Fig. 8

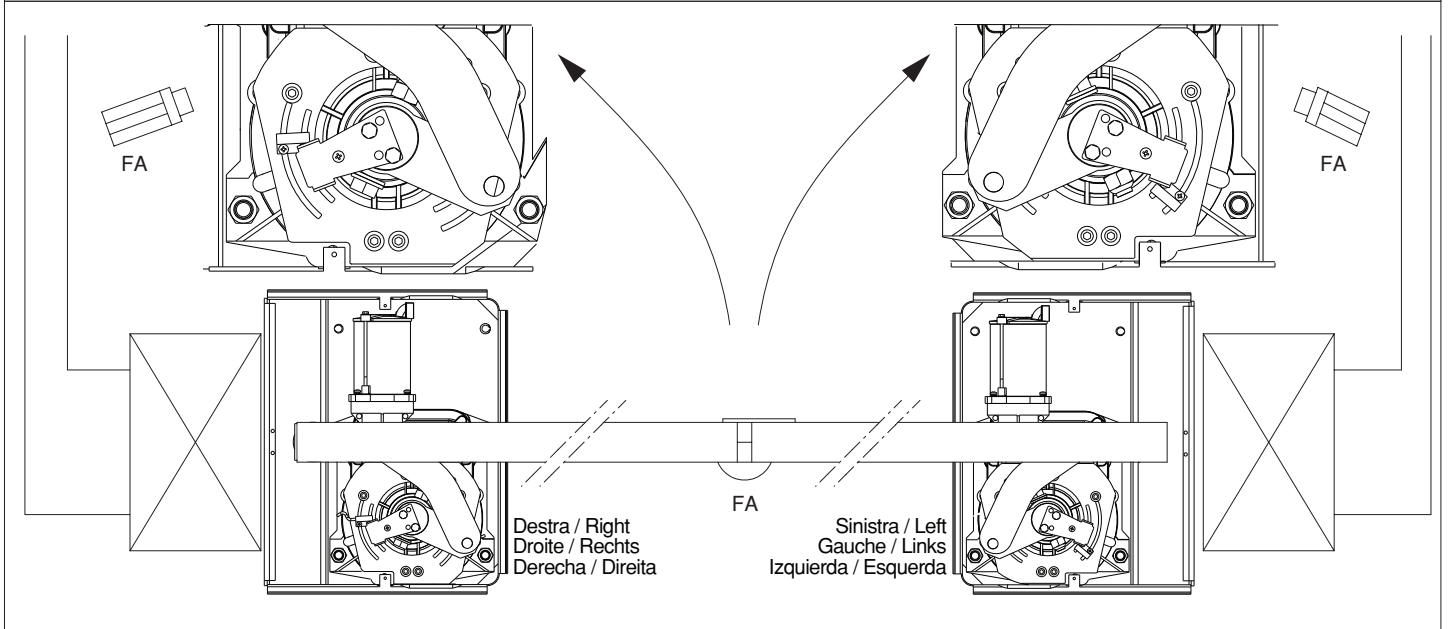

Fig. 9

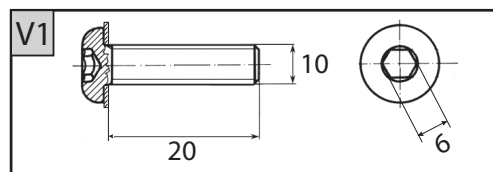
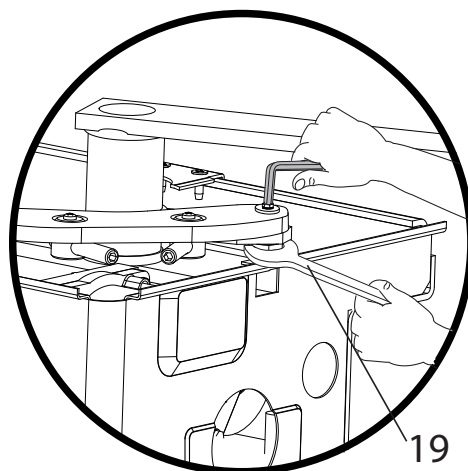
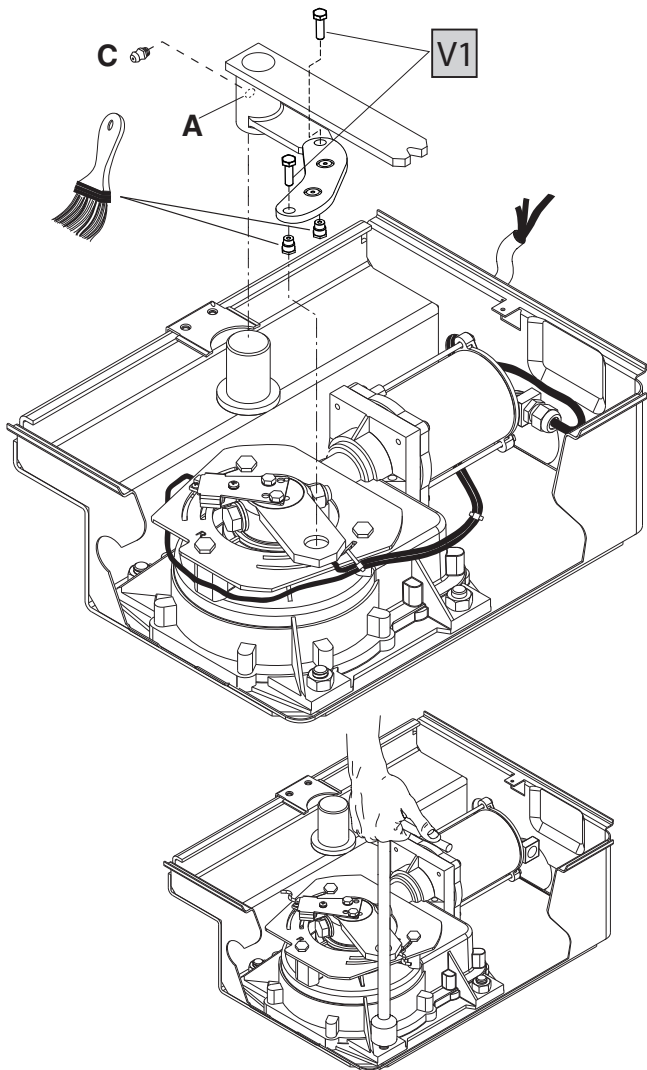

Fig. 10

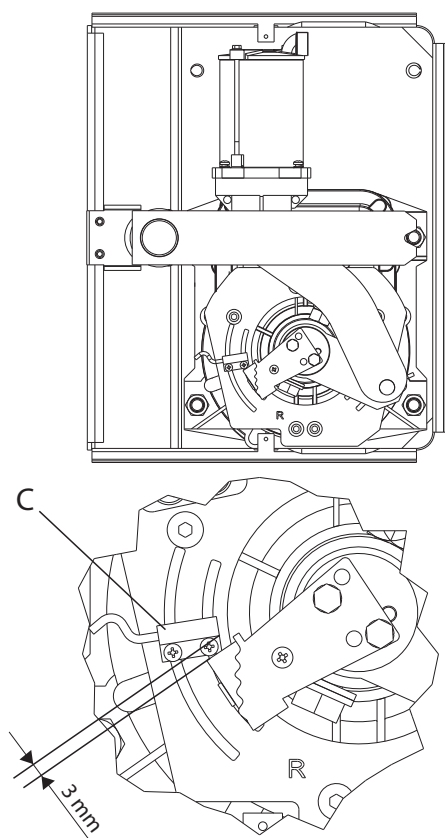

Fig. 10A

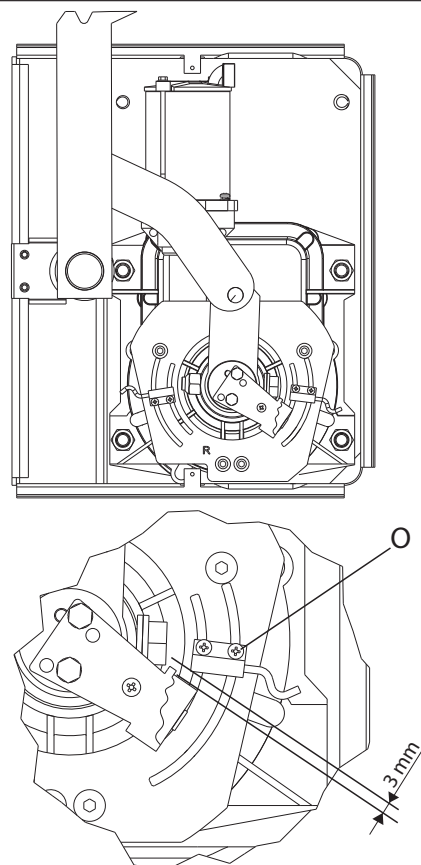

Fig. 10B

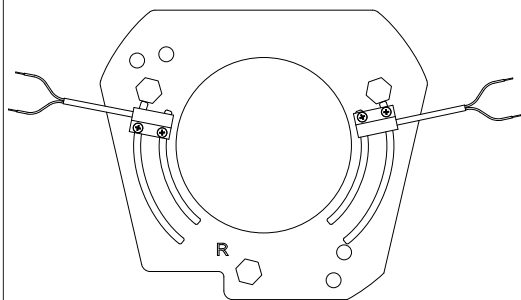

Fig. 11-11A

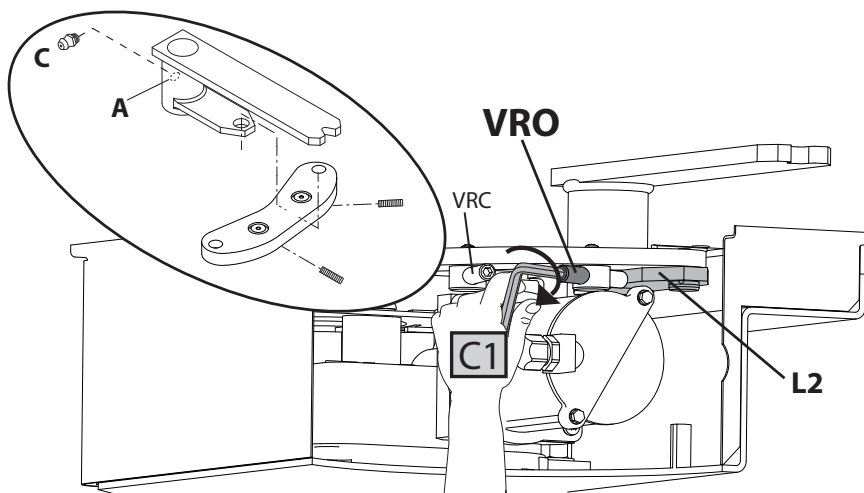

Fig.11B

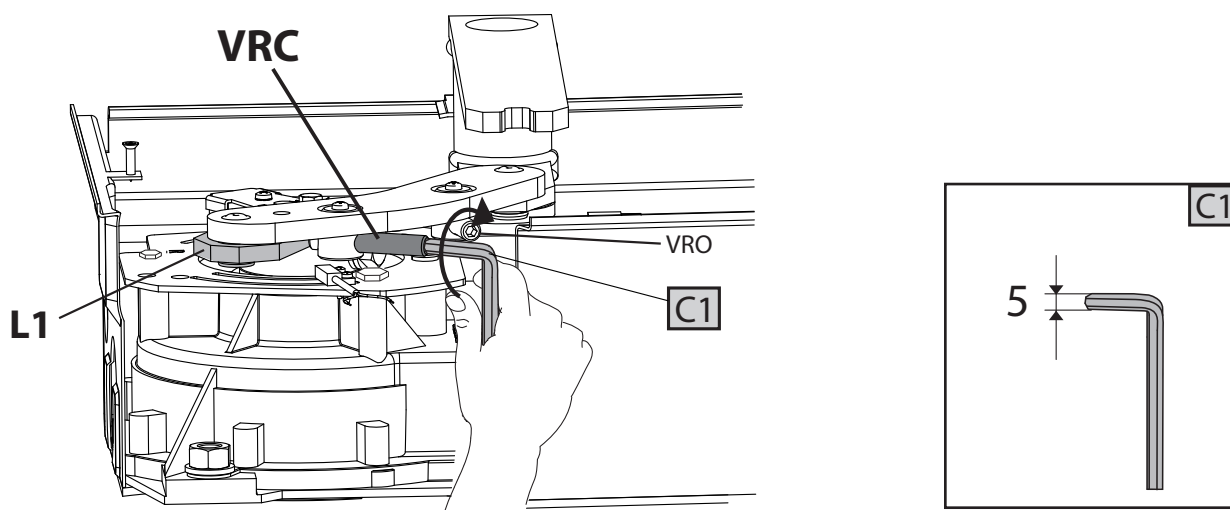

Fig. 12

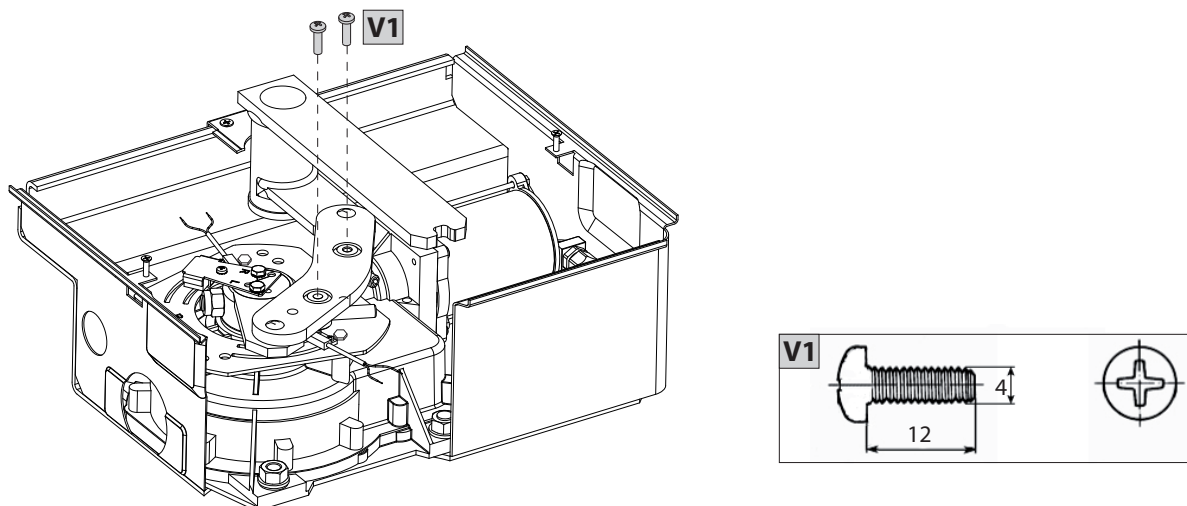

Fig. 13

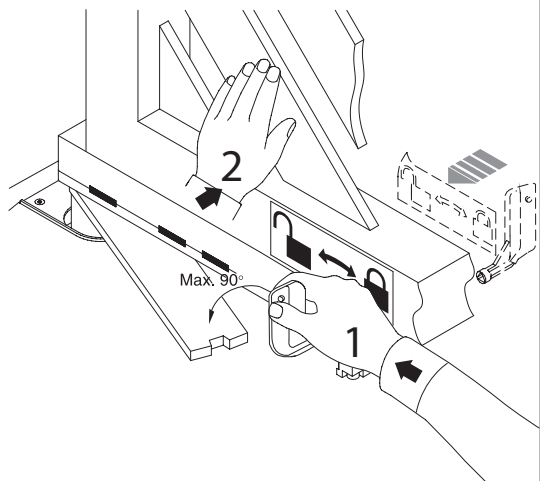

Fig. 14

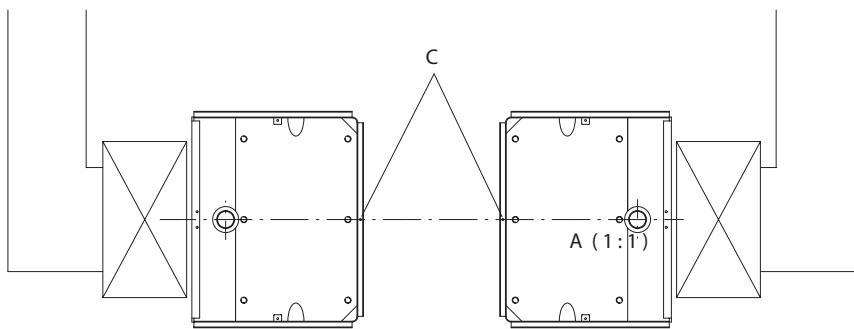
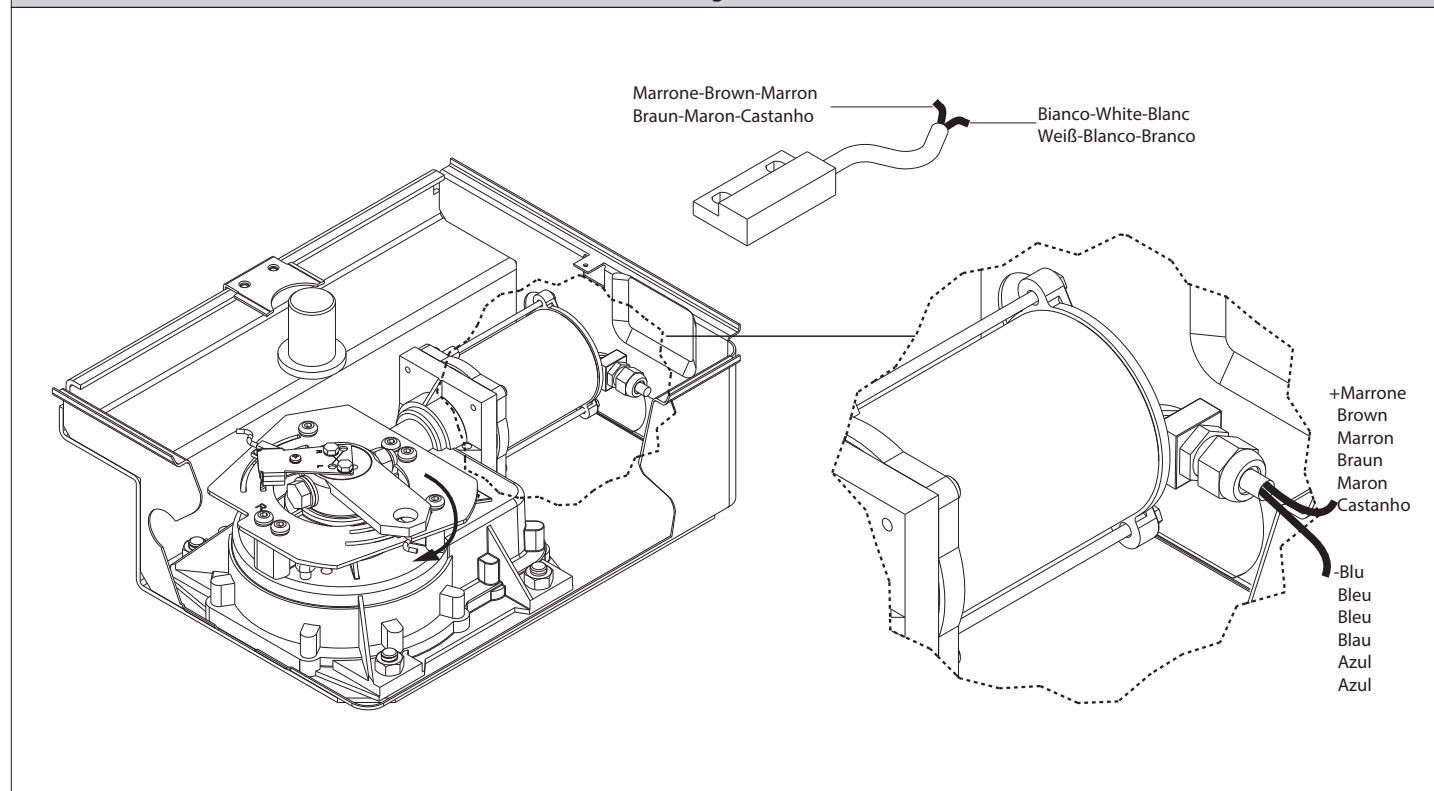

Fig. 15



## INSTALLER WARNINGS

**WARNING! Important safety instructions. Carefully read and comply with all the warnings and instructions that come with the product as incorrect installation can cause injury to people and animals and damage to property. The warnings and instructions give important information regarding safety, installation, use and maintenance. Keep hold of instructions so that you can attach them to the technical file and keep them handy for future reference.**

### GENERAL SAFETY

This product has been designed and built solely for the purpose indicated herein. Uses other than those indicated herein might cause damage to the product and create a hazard.

- The units making up the machine and its installation must meet the requirements of the following European Directives, where applicable: 2004/108/EC, 2006/95/EC, 2006/42/EC, 89/106/EC, 99/05/EC and later amendments. For all countries outside the EEC, it is advisable to comply with the standards mentioned, in addition to any national standards in force, to achieve a good level of safety.
- The Manufacturer of this product (hereinafter referred to as the "Firm") disclaims all responsibility resulting from improper use or any use other than that for which the product has been designed, as indicated herein, as well as for failure to apply Good Practice in the construction of entry systems (doors, gates, etc.) and for deformation that could occur during use.
- Installation must be carried out by qualified personnel (professional installer, according to EN 12635), in compliance with Good Practice and current code.
- Before installing the product, make all structural changes required to produce safety gaps and to provide protection from or isolate all crushing, shearing and dragging hazard areas and danger zones in general in accordance with the provisions of standards EN 12604 and 12453 or any local installation standards. Check that the existing structure meets the necessary strength and stability requirements.
- Before commencing installation, check the product for damage.
- The Firm is not responsible for failure to apply Good Practice in the construction and maintenance of the doors, gates, etc. to be motorized, or for deformation that might occur during use.
- Make sure the stated temperature range is compatible with the site in which the automated system is due to be installed.
- Do not install this product in an explosive atmosphere: the presence of flammable fumes or gas constitutes a serious safety hazard.
- Disconnect the electricity supply before performing any work on the system. Also disconnect buffer batteries, if any are connected.
- Before connecting the power supply, make sure the product's ratings match the mains ratings and that a suitable residual current circuit breaker and overcurrent protection device have been installed upline from the electrical system. Have the automated system's mains power supply fitted with a switch or omnipolar thermal-magnetic circuit breaker with a contact separation that provide full disconnection under overvoltage category III conditions.
- Make sure that upline from the mains power supply there is a residual current circuit breaker that trips at no more than 0.03A as well as any other equipment required by code.
- Make sure the earth system has been installed correctly: earth all the metal parts belonging to the entry system (doors, gates, etc.) and all parts of the system featuring an earth terminal.
- Installation must be carried out using safety devices and controls that meet standards EN 12978 and EN 12453.
- Impact forces can be reduced by using deformable edges.
- In the event impact forces exceed the values laid down by the relevant standards, apply electro-sensitive or pressure-sensitive devices.
- Apply all safety devices (photocells, safety edges, etc.) required to keep the area free of impact, crushing, dragging and shearing hazards. Bear in mind the standards and directives in force, Good Practice criteria, intended use, the installation environment, the operating logic of the system and forces generated by the automated system.
- Apply all signs required by current code to identify hazardous areas (residual risks). All installations must be visibly identified in compliance with the provisions of standard EN 13241-1.
- Once installation is complete, apply a nameplate featuring the door/gate's data.
- This product cannot be installed on leaves incorporating doors (unless the motor can be activated only when the door is closed).
- If the automated system is installed at a height of less than 2.5 m or is accessible, the electrical and mechanical parts must be suitably protected.
- Install any fixed controls in a position where they will not cause a hazard, away from moving parts. More specifically, hold-to-run controls must be positioned within direct sight of the part being controlled and, unless they are key operated, must be installed at a height of at least 1.5 m and in a place where they cannot be reached by the public.
- Apply at least one warning light (flashing light) in a visible position, and also attach a Warning sign to the structure.
- Attach a label near the operating device, in a permanent fashion, with information on how to operate the automated system's manual release.
- Make sure that, during operation, mechanical risks are avoided or relevant protective measures taken and, more specifically, that nothing can be banged, crushed, caught or cut between the part being operated and surrounding parts.
- Once installation is complete, make sure the motor automation settings are correct and that the safety and release systems are working properly.
- Only use original spare parts for any maintenance or repair work. The Firm disclaims all responsibility for the correct operation and safety of the automated system if parts from other manufacturers are used.
- Do not make any modifications to the automated system's components unless explicitly authorized by the Firm.
- Instruct the system's user on what residual risks may be encountered, on the control systems that have been applied and on how to open the system manually in an emergency. give the user guide to the end user.
- Dispose of packaging materials (plastic, cardboard, polystyrene, etc.) in accordance with the provisions of the laws in force. Keep nylon bags and polystyrene out of reach of children.

### WIRING

**WARNING!** For connection to the mains power supply, use: a multicore cable with a cross-sectional area of at least 5x1.5mm<sup>2</sup> or 4x1.5mm<sup>2</sup> when dealing with three-phase power supplies or 3x1.5mm<sup>2</sup> for single-phase supplies (by way of example, type H05 VV-F cable can be used with a cross-sectional area of 4x1.5mm<sup>2</sup>). To connect auxiliary equipment, use wires with a cross-sectional area of at least 0.5 mm<sup>2</sup>.

- Only use pushbuttons with a capacity of 10A-250V or more.
- Wires must be secured with additional fastening near the terminals (for example, using cable clamps) in order to keep live parts well separated from safety extra low voltage parts.
- During installation, the power cable must be stripped to allow the earth wire to be connected to the relevant terminal, while leaving the live wires as short as possible. The earth wire must be the last to be pulled taut in the event the cable's fastening device comes loose.

**WARNING!** safety extra low voltage wires must be kept physically separate from low voltage wires.

Only qualified personnel (professional installer) should be allowed to access live parts.

### CHECKING THE AUTOMATED SYSTEM AND MAINTENANCE

Before the automated system is finally put into operation, and during maintenance work, perform the following checks meticulously:

- Make sure all components are fastened securely.
- Check starting and stopping operations in the case of manual control.
- Check the logic for normal or personalized operation.
- For sliding gates only: check that the rack and pinion mesh correctly with 2 mm of play along the full length of the rack; keep the track the gate slides on clean and free of debris at all times.
- For sliding gates and doors only: make sure the gate's running track is straight and horizontal and that the wheels are strong enough to take the weight of the gate.
- For cantilever sliding gates only: make sure there is no dipping or swinging during operation.
- For swing gates only: make sure the leaves' axis of rotation is perfectly vertical.
- For barriers only: before opening the door, the spring must be decompressed (vertical boom).
- Check that all safety devices (photocells, safety edges, etc.) are working properly and that the anti-crush safety device is set correctly, making sure that the force of impact measured at the points provided for by standard EN 12445 is lower than the value laid down by standard EN 12453.
- Impact forces can be reduced by using deformable edges.
- Make sure that the emergency operation works, where this feature is provided.
- Check opening and closing operations with the control devices applied.
- Check that electrical connections and cabling are intact, making extra sure that insulating sheaths and cable glands are undamaged.
- While performing maintenance, clean the photocells' optics.
- When the automated system is out of service for any length of time, activate the emergency release (see "EMERGENCY OPERATION" section) so that the operated part is made idle, thus allowing the gate to be opened and closed manually.
- If the power cord is damaged, it must be replaced by the manufacturer or their technical assistance department or other such qualified person to avoid any risk.
- If "D" type devices are installed (as defined by EN 12453), connect in unverified mode, foresee mandatory maintenance at least every six months
- The maintenance described above must be repeated at least once yearly or at shorter intervals where site or installation conditions make this necessary.

### WARNING!

Remember that the drive is designed to make the gate/door easier to use and will not solve problems as a result of defective or poorly performed installation or lack of maintenance



### SCRAPPING

Materials must be disposed of in accordance with the regulations in force. Do not throw away your discarded equipment or used batteries with household waste. You are responsible for taking all your waste electrical and electronic equipment to a suitable recycling centre.

### DISMANTLING

If the automated system is being dismantled in order to be reassembled at another site, you are required to:

- Cut off the power and disconnect the whole electrical system.
- Remove the actuator from the base it is mounted on.
- Remove all the installation's components.
- See to the replacement of any components that cannot be removed or happen to be damaged.

**THE DECLARATION OF CONFORMITY CAN BE VIEWED ON THIS WEBSITE: WWW.BFT.IT IN THE PRODUCT SECTION.**

**Anything that is not explicitly provided for in the installation manual is not allowed. The operator's proper operation can only be guaranteed if the information given is complied with. The Firm shall not be answerable for damage caused by failure to comply with the instructions featured herein.**

**While we will not alter the product's essential features, the Firm reserves the right, at any time, to make those changes deemed opportune to improve the product from a technical, design or commercial point of view, and will not be required to update this publication accordingly.**



Thank you for buying this product, our company is sure that you will be more than satisfied with the performance of the product. This product is supplied with a "Warnings" leaflet and an "Instruction manual". These should both be read carefully as they provide important information about safety, installation, operation and maintenance.

**WARNINGS: Any assistance required on automation components must be carried out by a qualified technician (installer).**

## 2) GENERAL OUTLINE

The **ELI 250 BT** electromechanical actuator is the ideal solution for underground hinge-pivot installation. The actuator consists of a perfectly sealed single-block reduction gear. The under hinge-pivot position maintains the aesthetic appearance of the gate and practically hides the automation system.

Once the bearing case is installed, the gate can be operated even without fitting the actuator which can be inserted later. When maintenance is required, this type of case allows the actuator to be taken out without removing the gate leaf. The **ELI 250 BT** actuator can be fitted to any type of swing gate which meets the values shown in the "Technical Specifications" table. The pushing force is set on the control unit (see specific manual).

The end-of-stroke operation is controlled by special end-of-stroke magnetic sensors and by mechanical stop blocks located inside the foundation case.

**CAUTION! The actuator mod. ELI 250 BT is not provided with mechanical torque adjustment. It is compulsory to use a control board of the same manufacturer, according to the basic safety requirements of directives 2006/95/CEE, 2004/108/CEE, 2006/42/CEE and provided with adequate electric torque adjustment.**

## 3) MAIN AUTOMATION PARTS

Sealed mechanical actuator (fig.1) including:

- a) 24V $\overline{=}$  permanent magnet motor.
- b) Double worm-screw reduction gear with output gear in special aluminium alloy.
- c) Exit lever, end-of-stroke sensors and mechanical stop blocks.
- d) Bearing foundation case (ready for automation).
- e) Series of levers for gate movement.
- f) Release unit with key.

**CAUTION!** The actuator can be fitted either on the left or on the right, which are conventionally defined by looking at the gate from the inside (opening direction).

## 4) TECHNICAL SPECIFICATIONS

Power supply .....	24V $\overline{=}$ (*)
Motor revolutions.....	2100
Output shaft revolutions .....	1,45 min <sup>-1</sup>
Absorbed power .....	175W
Absorbed current.....	10,1 A max
Leaf rotation speed: .....	from 8°/sec. (15 sec./120°) to 4°/sec. (30 sec./120°)
Max torque.....	350 Nm
Max leaf length/weight.....	2.5m/4000N (~400kg) 3.5m/2500N (~250kg)
Max. leaf opening.....	120°
Blocking function.....	
Irreversible gearmotor; electric lock .....	necessary for leaves longer than 2,5m
Impact reaction.....	Electronic clutch (with control panel)
Manual manoeuvre .....	Release key
Max. no. manoeuvres in 24 hours.....	100
Environmental conditions.....	from -20°C to +50°C
Lubrication.....	Permanent grease
Degree of protection.....	IP67 AM
Actuator weight.....	100N (~ 10kg)
Overall dimensions.....	See fig.3
(*) Special voltages on request.	

## 5) ACTUATOR INSTALLATION

### 5.1) Preliminary checks

Check that:

- The upper hinge is in good condition and possibly adjustable.
- A hole can be dug for burying the case under the hinge.
- The "FA" stop plates of the leaves are installed (fig.8).
- Repair or replace the faulty or worn parts of the structures to be subjected to movement.

An exploded view of the installation is shown in fig.1.

**The automation reliability and safety are directly influenced by the state of the gate structure.**

### 5.2) The main automation components are (Fig.2):

- I) Type-approved adequately rated omnipolar circuit breaker with at least 3,5 mm contact opening, provided with protection against overloads and short circuits, suitable for cutting out automation from the mains. Place, if not already installed, a type-approved differential switch with a 0.03A threshold just before the automation system.
- Qr) Control panel and built-in receiver.
- S) Key selector.

- AL) Blinker with tuned antenna.
- M) Actuator.
- E) Electric lock (compulsory for leaves longer than 2,5m).
- Fte) Pair of external photocells (transmitter section).
- Fre) Pair of external photocells (receiver section).
- Fti) Pair of internal photocells with CF posts (transmitter section).
- Fri) Pair of internal photocells with CF posts (receiver section).
- T) 1-2-4 channel transmitter.
- RG58) Cable for antenna.
- D) Connector block.

### 5.3) Electrical installation set-up

Lay out the electrical installation as shown in fig. 2, with reference to the CEI 64-8 and IEC 364 provisions, complying with the HD 384 and other national standards in force for electrical installation. The mains power supply connections must be kept totally separate from the service connections (photocells, electric edges, control devices etc.).

**WARNING! It is recommended to use the following cables:**

- **Connection to the mains: multipolar cable with minimum cross section of 3x1.5 sq mm.**
- **Connection to the control unit:**
  - Operator farthest from the control unit (Fig.2)  
**for the motor: 2x2.5 sq mm cables;**  
**for the limit switch sensors: 3x1 sq mm cables.**
  - Operator nearest to the control unit (Fig.2)  
**for the motor: 2x1.5 sq mm cables;**  
**for the limit switch sensors: 3x1 sq mm cables.**

Connect the control and safety devices in compliance with the previously mentioned electrical installation standards. Fig. 2 shows the number of connections and the cross section for cables having a length of approximately 100 metres; in case of longer cables, calculate the cross section for the actual automation load. **Warning!** For actuator wiring and accessory connection, refer to the relevant instruction manuals. The control panels and accessories must be suitable for use and conform to current standards.

### 5.4) Foundation case cementing

The foundation case must be cemented under the hinge pivot, taking into consideration that the actuator bearing shaft must be perfectly aligned with the leaf rotation axis. If the gate has fixed hinges, remove the gate and the lower hinge. If the leaf is sufficiently separated from the ground and cannot be removed, proceed to supporting it by means of a shim placed between the ground and the leaf during installation. If the gate has adjustable hinges, remove the lower one, slacken the upper hinge and move the leaf to the side. If the gate has been recently installed, fit an upper adjustable hinge. Dig a foundation hole having the dimensions specified in fig.4. Lay a drain pipe (fig. 4) for rainwater in order to prevent it from being collected inside the foundation case. Lay a raceway for the power supply cable as far as connector block "D". Lay a solid foundation (fig.3) at the bottom, where to bury the foundation box. To obtain good squareness between cases and leaves, set out their alignment using a stretched rope between the 2 bearing pivots, and aligning the 2 reference points "C" with each other (see fig.14). Let the cement harden for the time needed.

### 6) GATE LEAF FITTING

- Abundantly grease the pivot in the foundation case.
  - Position the lever assembly by inserting pipe "A" into the pivot of the foundation case, as in fig.9. If the height of the assembled levers is not sufficient, insert shim "S" between the assembled lever unit and the gate leaf, as in fig.5.
  - Place the gate leaves in the closing and in the closed position against the centre stop plate.
  - Perfectly align the assembled lever unit to the hinge.
  - If a shim is used, weld it to the leaf first and then weld the lever unit to the shim.
  - Check the leaf operation.
  - If the gearmotor is not to be installed, fit the foundation case cover and fix with suitable screws.
- At this stage, the gate opens and closes manually. All that remains to be done is to position the gearmotor.

### 7) GEARMOTOR FITTING

Remove the nuts from the bottom of the case using a CH19 socket wrench.

- Fit the end-of-stroke sensors (Fig. 6A).
  - Select left-hand or right-hand fixing position (Fig.6A).
- Plate sides are marked as follows: **R** - RIGHT SIDE  
**L** - LEFT SIDE
- Secure the plate on the gearmotor by means of the three M8 screws as shown in Fig. 6B. After mounting the gearmotor on the foundation case, connect the control unit in order to be able to move the output lever and then tighten the other two M8 screws (Fig.9).
  - Secure the magnet onto the plate as shown in Fig. 7. Then install the plate assembly onto the gearmotor outlet shaft and determine the diagonal position of the holes (R-L) for right or left fastening (Fig.7).
  - Secure the gearmotor to the foundation case in the position indicated in Fig. 9 using the 4 nuts previously removed.

- Pass the cables of the end-of-stroke sensors so that they do not touch the moving parts (Fig.9).
- Pass the cables of the end-of-stroke sensors so that they do not touch the moving parts (Fig.9).
- Fit the motor-pivot connecting lever components following the correct sequence given in fig.8 and fig.9.  
In the case where the position of the levers interferes with the assembly of the components, supply the motors with current (by means of the control unit) until the levers reach the required position.
- Grease the hub into which pipe A will be inserted and the hubs of lever B (Fig.9).
- Check the opening and closing operations.
- Attach to the leaf the internal and external release labels observing the direction and position indicated in fig.13. The open-padlock symbol must always be directed towards the leaf rotation axis.

## 8) END-OF-STROKE ADJUSTMENT

- 1- Position the sensors on the plates as indicated in fig. 10B. Connect the limit switches of both motors and the cables supplying power to motor 2 to the control unit.
- 2- Electrically open the leaf of motor drive 2 until it reaches the maximum opening position required.
- 3- Position the opening sensor (ref. O) as in fig. 10A, keeping to the measurement of less than 3 mm from the magnet, then fix it in place by means of the appropriate screws.
- 4- Carry out the same procedure to move the leaf to its closing position, and fit the sensor with ref. C in fig. 10.
- 5- Connect motor 1 and repeat the adjusting procedure while keeping motor 2 connected.
- 6- Having adjusted the limit switch sensors of the two motors, carry out a few manoeuvres to check the stopping position of the leaves, and make any necessary modifications.
- 7- Proceed to adjust the internal backstops by turning the screws (VRC - VRO) in fig. 11. This operation is required in the case where there are no "FA" backstops fitted to the ground (fig. 8).
- 8- To provide adequate pressure of the leaf against the end stop, regulate screws VRO - VRC (fig. 11A, fig. 11B).
- 9- Once the adjustment has been completed, secure screws VRO - VRC by means of respective screws vt 4 x 12 (Fig.12).
- 10- Connections of the gearmotor cable and the limit switches must be carried out in a junction box positioned outside the foundation case without cutting the cable supplied as standard (Fig.4).
- 11- Fig.11: insert the greaser (C) into the threaded hole (A) of the lever (B). The type of grease recommended is: ROCOL FOODLUBE MULTIPASTE.

## 9) MOTOR TORQUE SETTING

**CAUTION!** The power supply for the motor must be rated at 25 V.

When using the **ARIES** mod. control unit with the torque set to "F4" (maximum torque), it is compulsory to fit the ground stop plates "FA" both on opening and closing.

The motor torque (antisquash) setting takes place in the control unit. See the control unit instruction manual. The wiring diagram of the motor is included in the instructions for use for the relative control unit. This setting must be calibrated according to the minimum force needed to carry out the complete opening and closing strokes, and always within the limits provided for by current standards.

**CAUTION!** Excessive torque setting can jeopardise antisquash safety. On the contrary, insufficient torque setting may not guarantee a correct opening or closing stroke.

## 10) EMERGENCY MANOEUVRE

Emergency release is obtained by using the key provided, on the release unit which is located under the gate, on the protruding section of the lever-pivot. To release, insert the key in the release triangle and turn it by about 90° in the direction shown by the open-padlock symbol (fig.13). If the leaf is equipped with an electric lock, release the electric lock as well.

To open/close the gate, push it manually. To restore motor-driven operation, reposition the gate by aligning it with the lever bearing the lock unit, and turn the key in the direction shown by the closed-padlock symbol (fig.13) checking that engagement is correctly restored. Keep the leaf release key (and that of the electric lock, if any) in a place which is known to the users.

## 11) AUTOMATION CHECK

Before making the automation fully operational, carefully carry out the following procedure:

- Check that all components are tightly fixed.
- Check the correct operation of all safety devices (photocells, electric edges etc.).
- Check the emergency manoeuvre command.
- Check the opening and closing operations with the control devices provided.
- Check the standard or customised electronic function logic.

## 12) AUTOMATION OPERATION

Since the automation system can be remotely controlled by means of a radio control device or a Start button, and therefore out of sight, all safety devices must be frequently checked in order to ensure their perfect efficiency. In the event of any anomalous operation, request immediate assistance from qualified personnel. Children must be kept at a safe distance from the automation operation area.

## 13) CONTROL

The automation system allows motor-driven gate opening and closing operations to be carried out. Various types of control are provided (manual, radio control, magnetic card access control etc.) depending on the installation requirements and characteristics. See the specific instructions for the various control systems. All automation system users must be instructed on automation control and operation.

## 14) MAINTENANCE

Before carrying out any maintenance to the installation, disconnect the mains power supply.

- Periodically check that hinge-pivots are in good condition and properly greased.
- Grease the pin on the foundation case every two years, using the appropriate greaser (C) located on the lever (B) as shown in Fig.11.
- Occasionally clean the photocell optical components.
- Have a qualified technician (installer) check the correct setting of the electric clutch.
- If the power supply cable is damaged, it must be replaced by the manufacturer or its technical assistance service, or else by a suitably qualified person, in order to prevent any risk.
- When any operational malfunction is found, and not resolved, disconnect the mains power supply and request the assistance of a qualified technician (installer). When automation is out of order, activate the manual release to allow the opening and closing operations to be carried out manually.

## 15) NOISE

The aerial noise produced by the gearmotor under normal operating conditions is constant and does not exceed 70dB(A).

## 16) MALFUNCTION: CAUSES AND REMEDIES

When any operational malfunction is found, and not resolved, disconnect the mains power supply and request the assistance of a qualified technician (installer).

When automation is out of order, activate the manual release to allow the opening and closing operations to be carried out manually.

During this period of time, keep the lock in the closed position by means of a chain and padlock.

### 16.1) The gate does not open. The motor does not turn.

- a) Check that the photocells or electric edges are not dirty, or impregnated, or misaligned. Proceed accordingly.
- b) Check that the electronic appliance is correctly supplied. Check the integrity of the fuses.
- c) Check that the individual devices operate correctly.
- d) If the control unit does not work, it must be replaced.  
In the case where the above-mentioned checks give no results, contact an authorised customer service centre.

**If the supply cable is damaged, it must be replaced by the manufacturer, by its technical service center or, in any case, by a qualified technician so as to avoid any risk.**

### 16.2) The gate does not open. The actuator vibrates but there is no movement.

- a) Disconnect and reconnect the mains power supply. The first Start command must open. Should the actuator move to the closing function, reverse the respective running connections.
- b) Manually help the leaf opening operation. If the leaf opens, check whether there are any mechanical problems. In the case where the above-mentioned checks give no results, increase the torque in the control unit and, if necessary, contact a qualified technician.

Fig. 1

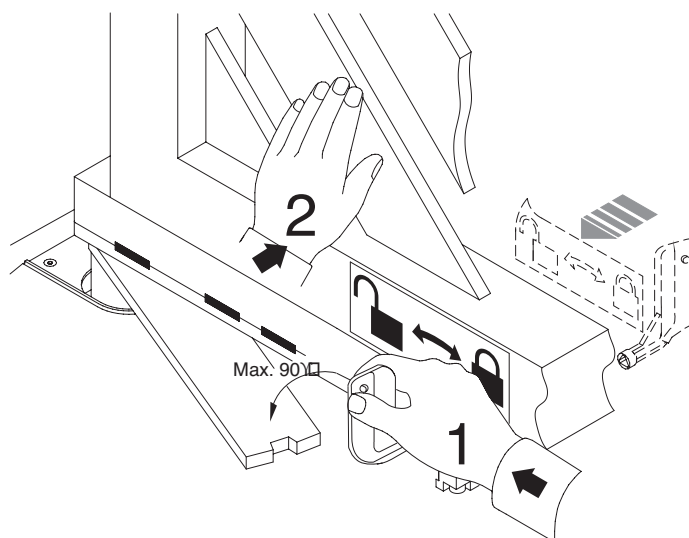

#### MANOVRA DI EMERGENZA (Fig.1) (I)

Lo sblocco di emergenza si effettua agendo, con l'apposita chiave in dotazione, sul gruppetto sblocco situato sotto il cancello sulla parte sporgente della leva-perno. Per sbloccare, inserire la chiave nel triangolo di sblocco e ruotare la chiave verso l'indicazione del lucchetto aperto per circa 90° (fig.1).

Se l'anta è dotata di elettroserratura, sbloccare anche l'elettroserratura. Spingere manualmente l'anta per aprire/chiudere il cancello. Per ripristinare l'operazione motorizzata, riposizionare il cancello allineato con la leva che porta il gruppo blocco e girare la chiave verso l'indicazione del lucchetto chiuso (fig.1) avendo cura di controllare l'avvenuto aggancio dell'anta. Riporre la chiave di sblocco anta (e dell'elettroserratura se presente) in luogo conosciuto agli utilizzatori.

#### EMERGENCY MANOEUVRE (Fig.1) (GB)

Emergency release is obtained by using the key provided, on the release unit which is located under the gate, on the protruding section of the lever-pivot. To release, insert the key in the release triangle and turn it by about 90° in the direction shown by the open-padlock symbol (fig.1). If the leaf is equipped with an electric lock, release the electric lock as well. To open/close the gate, push it manually. To restore motor-driven operation, reposition the gate by aligning it with the lever bearing the lock unit, and turn the key in the direction shown by the closed-padlock symbol (fig.1) checking that engagement is correctly restored. Keep the leaf release key (and that of the electric lock, if any) in a place which is known to the users.

#### MANŒUVRE D'URGENCE (Fig.1) (F)

Le déblocage d'urgence se fait en agissant, avec la clé spéciale fournie en dotation, sur le groupe de

déblocage situé sous le portail sur la partie saillante du levier-pivot. Per effectuer le déblocage, enfoncer la clé dans le triangle de déblocage et tourner la clé vers l'indication du cadenas ouvert pour environ 90° (fig.1). Si le vantail est doté d'électroserrure, débloquer aussi l'électroserrure. Pousser le vantail manuellement pour ouvrir/fermer le portail.

Pour rétablir le fonctionnement motorisé, repositionner le portail aligné avec le levier portant le groupe de blocage et tourner la clé vers l'indication du cadenas fermé (fig.1) en ayant soin de contrôler si le vantail s'est accroché. Ranger la clé de déblocage du vantail (et de l'électroserrure, si existante) dans un lieu connu per les utilisateurs.

#### BEDIENUNG IM NOTFALL (Abb.1) (D)

Die Entsperrung im Notfall erfolgt durch den beiliegenden Schlüssel, der in die Entsperrungsvorrichtung gesteckt wird. Sie befindet sich unter dem Tor auf dem hervorragenden Bestandteil der Einheit Hebel-Zapfen. Zur Entsperrung ist der Schlüssel in das Entsperrungsdreieck einzusetzen und um ca. 90° in die Richtung des angezeigten offenen Vorhängeschlosses zu drehen (Abb.1). Sofern der Flügel über ein Elektroschloß verfügt, muß auch das Elektroschloß entsperrt werden. Den Flügel von Hand drücken, um das Tor zu öffnen bzw. zu schließen. Um den Motorbetrieb wiederaufzunehmen, ist das Tor auf einer Linie mit dem Hebel, der die Blockierungsvorrichtung trägt, auszurichten. Drehen Sie den Schlüssel in die Richtung des angezeigten geschlossenen Vorhängeschlosses (Abb.1). Überprüfen Sie, ob die Einheit wieder richtig eingerastet ist. Bewahren Sie den Schlüssel zur Entsperrung (und des Elektroschlosses, falls vorhanden) an einem Ort auf, der allen Benutzern bekannt ist.



### **MANIOBRA DE EMERGENCIA (Fig.1) (E)**

El desbloqueo de emergencia se efectúa actuando, con la llave expresamente asignada, sobre el grupo de desbloqueo situado debajo de la cancela, en la parte saliente de la palanca-perno. Para desbloquear, hay que insertar la llave en el triángulo de desbloqueo y girarla hacia la indicación del candado abierto unos 90° (fig.1). Si la hoja está dotada de electrocerradura, ésta también tiene que desbloquearse. Empujar manualmente la hoja para abrir y cerrar la cancela. Para restablecer la operación motorizada, hay que volver a alinear la cancela con la palanca de accionamiento del grupo de bloqueo y girar la llave hacia la indicación del candado cerrado (fig.1), controlando que la hoja se haya enganchado efectivamente. La llave de desbloqueo de la hoja (y de la electrocerradura, si está presente) debe guardarse en un lugar conocido por los usuarios.

### **MANUAL DE USO (Fig.1) (P)**

Efetua-se o desbloqueio de emergência, atuando com a chave específica em dotação, sobre o conjunto de desbloqueio localizado sob o portão na parte saliente da alavanca eixo. Para desbloquear, introduzir a chave no triângulo de desbloqueio e girar a mesma em direção da indicação de cadeado aberto por aproximadamente 90° (fig.1). Se a folha do portão for dotada de fechadura elétrica, desbloquear também a fechadura elétrica. Empurrar manualmente a folha do portão para abrir/fechar o mesmo. Para retornar à operação motorizada, reposicionar o portão alinhado com a alavanca que tem o conjunto de bloqueio e girar a chave em direção da indicação do cadeado fechado (fig.1) tendo o cuidado de verificar a ocorrência do engate da folha do portão. Repor a chave de desbloqueio da folha do portão (e da fechadura elétrica se presente) em local conhecido aos usuários.

## AVVERTENZE PER L'UTILIZZATORE ( I )

**ATTENZIONE! Importanti istruzioni di sicurezza. Leggere e seguire attentamente le Avvertenze e le Istruzioni che accompagnano il prodotto poiché un uso improprio può causare danni a persone, animali o cose. Conservare le istruzioni per consultazioni future e trasmetterle ad eventuali subentranti nell'uso dell'impianto.**

**Questo prodotto dovrà essere destinato solo all'uso per il quale è stato espressamente installato. Ogni altro uso è da considerarsi improprio e quindi pericoloso. Il costruttore non può essere considerato responsabile per eventuali danni causati da usi impropri, erronei e irragionevoli.**

### SICUREZZA GENERALE

Nel ringraziarVi per la preferenza accordata a questo prodotto, la Ditta è certa che da esso otterrete le prestazioni necessarie al Vostro uso.

Questo prodotto risponde alle norme riconosciute della tecnica e della disposizioni relative alla sicurezza se correttamente installato da personale qualificato ed esperto (installatore professionale). L'automazione, se installata ed utilizzata correttamente, soddisfa gli standard di sicurezza nell'uso. Tuttavia è opportuno osservare alcune regole di comportamento per evitare inconvenienti accidentali:

- Tenere bambini, persone e cose fuori dal raggio d'azione dell'automazione, in particolare durante il movimento.
- Non permettere a bambini di giocare o sostare nel raggio di azione dell'automazione.
- Questa automazione non è destinata all'uso da parte di bambini o da parte di persone con ridotte capacità mentali, fisiche e sensoriali, o persone che mancano di conoscenze adeguate a meno che esse non abbiano potuto beneficiare, attraverso l'intermediazione di una persona responsabile della loro sicurezza, di una sorveglianza o di istruzioni riguardanti l'uso dell'apparecchio.
- I bambini devono essere sorvegliati per sincerarsi che non giochino con l'apparecchio. Non permettere ai bambini di giocare con i controlli fissi. Tenere i telecomandi lontani dai bambini.
- Evitare di operare in prossimità delle cerniere o organi meccanici in movimento.
- Non contrastare il movimento dell'anta e non tentare di aprire manualmente la porta se non è stato sbloccato l'attuatore con l'apposita manopola di sblocco.
- Non entrare nel raggio di azione della porta o cancello motorizzati durante il loro movimento.
- Non lasciare radiocomandi o altri dispositivi di comando alla portata dei bambini onde evitare azionamenti involontari.
- L'attivazione dello sblocco manuale potrebbe causare movimenti incontrollati della porta se in presenza di guasti meccanici o di condizioni di squilibrio.
- In caso di apritapparelle: sorvegliare la tapparella in movimento e tenere lontano le persone finché non è completamente chiusa. Porre cura quando si aziona lo sblocco se presente, poiché una tapparella aperta potrebbe cadere rapidamente in presenza di usura o rotture.
- La rottura o l'usura di organi meccanici della porta (parte guidata), quali ad esempio cavi, molle, supporti, cardini, guide.. potrebbe generare pericoli. Far controllare periodicamente l'impianto da personale

qualificato ed esperto (installatore professionale) secondo quanto indicato dall'installatore o dal costruttore della porta.

- Per ogni operazione di pulizia esterna, togliere l'alimentazione di rete.
- Tenere pulite le ottiche delle fotocellule ed i dispositivi di segnalazione luminosa. Controllare che rami ed arbusti non disturbino i dispositivi di sicurezza.
- Non utilizzare l'automatismo se necessita di interventi di riparazione. In caso di guasto o di malfunzionamento dell'automazione, togliere l'alimentazione di rete sull'automazione, astenersi da qualsiasi tentativo di riparazione o intervento diretto e rivolgersi solo a personale qualificato ed esperto (installatore professionale) per la necessaria riparazione o manutenzione. Per consentire l'accesso, attivare lo sblocco di emergenza (se presente).
- Per qualsiasi intervento diretto sull'automazione o sull'impianto non previsto dal presente manuale, avvalersi di personale qualificato ed esperto (installatore professionale).
- Con frequenza almeno annuale far verificare l'integrità e il corretto funzionamento dell'automazione da personale qualificato ed esperto (installatore professionale), in particolare di tutti i dispositivi di sicurezza.
- Gli interventi d'installazione, manutenzione e riparazione devono essere documentati e la relativa documentazione tenuta a disposizione dell'utilizzatore.
- Il mancato rispetto di quanto sopra può creare situazioni di pericolo.



### DEMOLIZIONE

L'eliminazione dei materiali va fatta rispettando le norme vigenti. Non gettate il vostro apparecchio scartato, le pile o le batterie usate nei rifiuti domestici. Avete la responsabilità di restituire tutti i vostri rifiuti da apparecchiature elettriche o elettroniche lasciandoli in un punto di raccolta dedicato al loro riciclo.

Tutto quello che non è espressamente previsto nel manuale d'uso, non è permesso. Il buon funzionamento dell'operatore è garantito solo se vengono rispettate le prescrizioni riportate in questo manuale. La Ditta non risponde dei danni causati dall'inosservanza delle indicazioni riportate in questo manuale.

Lasciando inalterate le caratteristiche essenziali del prodotto, la Ditta si riserva di apportare in qualunque momento le modifiche che essa ritiene convenienti per migliorare tecnicamente, costruttivamente e commercialmente il prodotto, senza impegnarsi ad aggiornare la presente pubblicazione.

## USER WARNINGS (GB)

**WARNING! Important safety instructions. Carefully read and comply with the Warnings and Instructions that come with the product as improper use can cause injury to people and animals and damage to property. Keep the instructions for future reference and hand them on to any new users.**

**This product is meant to be used only for the purpose for which it was explicitly installed. Any other use constitutes improper use and, consequently, is hazardous. The manufacturer cannot be held liable for any damage as a result of improper, incorrect or unreasonable use.**



## GENERAL SAFETY

Thank you for choosing this product. The Firm is confident that its performance will meet your operating needs.

This product meets recognized technical standards and complies with safety provisions when installed correctly by qualified, expert personnel (professional installer).

If installed and used correctly, the automated system will meet operating safety standards. Nonetheless, it is advisable to observe certain rules of behaviour so that accidental problems can be avoided:

- Keep adults, children and property out of range of the automated system, especially while it is moving.
- Do not allow children to play or stand within range of the automated system.
- This automated system is not meant for use by children or by people with impaired mental, physical or sensory capacities, or people who do not have suitable knowledge, unless a person who is responsible for their safety provides them with necessary supervision or instructions on how to use the device.
- Children must be supervised to ensure they do not play with the device. Do not allow children to play with the fixed controls. Keep remote controls out of reach of children.
- Do not work near hinges or moving mechanical parts.
- Do not hinder the leaf's movement and do not attempt to open the door manually unless the actuator has been released with the relevant release knob.
- Keep out of range of the motorized door or gate while they are moving.
- Keep remote controls or other control devices out of reach of children in order to avoid the automated system being operated inadvertently.
- The manual release's activation could result in uncontrolled door movements if there are mechanical faults or loss of balance.
- When using roller shutter openers: keep an eye on the roller shutter while it is moving and keep people away until it has closed completely. Exercise care when activating the release, if such a device is fitted, as an open shutter could drop quickly in the event of wear or breakage.
- The breakage or wear of any mechanical parts of the door (operated part), such as cables, springs, supports, hinges, guides... may generate a hazard. Have the system checked by qualified, expert personnel (professional installer) at regular intervals according to the instructions issued by the installer or manufacturer of the door.
- When cleaning the outside, always cut off mains power.
- Keep the photocells' optics and illuminating indicator devices clean. Check that no branches or shrubs interfere with the safety devices.
- Do not use the automated system if it is in need of repair. In the event the automated system breaks down or malfunctions, cut off mains power to the system; do not attempt to repair or perform any other work to rectify the fault yourself and instead call in qualified, expert personnel (professional installer) to perform the necessary repairs or maintenance. To allow access, activate the emergency release (where fitted).
- If any part of the automated system requires direct work of any kind that is not contemplated herein, employ the services of qualified, expert personnel (professional installer).

- At least once a year, have the automated system, and especially all safety devices, checked by qualified, expert personnel (professional installer) to make sure that it is undamaged and working properly.
- A record must be made of any installation, maintenance and repair work and the relevant documentation kept and made available to the user on request.
- Failure to comply with the above may result in hazardous situations.



### SCRAPPING

Materials must be disposed of in accordance with the regulations in force. Do not throw away your discarded equipment or used batteries with household waste. You are responsible for taking all your waste electrical and electronic equipment to a suitable recycling centre.

**Anything that is not explicitly provided for in the user guide is not allowed. The operator's proper operation can only be guaranteed if the instructions given herein are complied with. The Firm shall not be answerable for damage caused by failure to comply with the instructions featured herein.**

**While we will not alter the product's essential features, the Firm reserves the right, at any time, to make those changes deemed opportune to improve the product from a technical, design or commercial point of view, and will not be required to update this publication accordingly.**

### AVERTISSEMENTS POUR L'UTILISATEUR (F)

**ATTENTION ! Instructions de sécurité importantes. Veuillez lire et suivre attentivement tous les avertissements et toutes les instructions fournis avec le produit sachant qu'un usage incorrect peut provoquer des préjudices aux personnes, aux animaux ou aux biens. Veuillez conserver les instructions pour d'ultérieures consultations et pour les transmettre aux propriétaires futurs éventuels.**

**Cet appareil ne peut être destiné qu'à l'usage pour lequel il a été expressément installé. Tout autre usage sera considéré comme impropre et donc dangereux. Le fabricant ne sera en aucun cas considéré comme responsable des préjudices dus à un usage impropre, erroné ou déraisonné.**

### SECURITE GENERALE

Nous vous remercions d'avoir choisi ce produit qui, nous n'en doutons pas, saura vous garantir les performances attendues.

Ce produit, correctement installé par du personnel qualifié et expérimenté (monteur professionnel) est conforme aux normes reconnues de la technique et des prescriptions de sécurité.

Si l'automatisation est montée et utilisée correctement, elle garantit la sécurité d'utilisation prescrite. Il est cependant nécessaire de respecter certaines règles de comportement pour éviter tout inconvénient accidentel.

- Tenir les enfants, les personnes et les objets à l'écart du rayon d'action de l'automatisation, en particulier pendant son fonctionnement.
- Empêcher les enfants de jouer ou de stationner dans le rayon d'action de l'automatisation.
- Cette automatisation n'est pas destinée à être utilisée par des enfants, des personnes ayant des capacités mentales, physiques et sensorielles

**Bft Spa**

Via Lago di Vico, 44  
36015 Schio (VI)  
T +39 0445 69 65 11  
F +39 0445 69 65 22  
→ [www.bft.it](http://www.bft.it)

**SPAIN**

**BFT GROUP ITALIBERICA DE  
AUTOMATISMOS S.L.**  
08401 Granollers - (Barcelona)  
[www.bftautomatismos.com](http://www.bftautomatismos.com)

**FRANCE**

**AUTOMATISMES BFT FRANCE**  
69800 Saint Priest  
[www.bft-france.com](http://www.bft-france.com)

**GERMANY**

**BFT TORANTRIEBSSYSTEME GmbH**  
90522 Oberasbach  
[www.bft-torantriebe.de](http://www.bft-torantriebe.de)

**UNITED KINGDOM**

**BFT AUTOMATION UK LTD**  
Stockport, Cheshire, SK7 5DA  
[www.bft.co.uk](http://www.bft.co.uk)

**IRELAND**

**BFT AUTOMATION LTD**  
Dublin 12

**BENELUX**

**BFT BENELUX SA**  
1400 Nivelles  
[www.bftbenelux.be](http://www.bftbenelux.be)

**POLAND**

**BFT POLSKA SP. Z O.O.**  
05-091 ZĄBKI  
[www.bft.pl](http://www.bft.pl)

**CROATIA**

**BFT ADRIA D.O.O.**  
51218 Drazice (Rijeka)  
[www.bft.hr](http://www.bft.hr)

**PORTUGAL**

**BFT SA-COMERCIO DE  
AUTOMATISMOS E MATERIAL DE  
SEGURANCIA**  
3020-305 Coimbra  
[www.bftportugal.com](http://www.bftportugal.com)

**CZECH REPUBLIC**

**BFT CZ S.R.O.**  
Praha  
[www.bft.it](http://www.bft.it)

**TURKEY**

**BFT OTOMATIK KAPI SISTEMELERI  
SANAY VE**  
Istanbul  
[www.bftotomasyon.com.tr](http://www.bftotomasyon.com.tr)

**RUSSIA**

**BFT RUSSIA**  
111020 Moscow  
[www.bftorus.ru](http://www.bftorus.ru)

**AUSTRALIA**

**BFT AUTOMATION AUSTRALIA  
PTY LTD**  
Wetherill Park (Sydney)  
[www.bftaustralia.com.au](http://www.bftaustralia.com.au)

**U.S.A.**

**BFT USA**  
Boca Raton  
[www.bft-usa.com](http://www.bft-usa.com)

**CHINA**

**BFT CHINA**  
Shanghai 200072  
[www.bft-china.cn](http://www.bft-china.cn)

**UAE**

**BFT Middle East FZCO**  
Dubai