

**COMPATIBLE WITH:**

**PHOBOS BT**

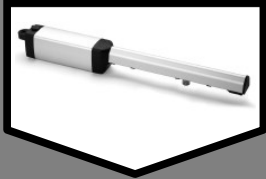

**IGEA BT**



**ECOSOL**  
LIBRA UL-R PRE-WIRED ENCLOSURE  
**INSTALLATION MANUAL**





**T-BOX WIRELESS KEYLESS ENTRY KEYPAD.** Self-contained, standalone access keypad. 10 channels, 100 codes capacity. Compatible with the ECOSOL built-in radio receiver. Part no. **P121019**



**RB WIRELESS WALLMOUNT CONTROL STATION.** Up to 4 systems can be controlled with this sleek 4 button station. For indoor or outdoor use. Part no. **P121016**



**SOLAR PANEL.** 10 watts, 24v. Up to 3 can be installed to the system for increased charging capacity. Part no. **N999471**



**HIGH CAPACITY BATTERIES.** 12V, 9 Ah. To replace or add to existing system. Up to 4 batteries can be installed in the enclosure. They must be added in pairs. Part no. **KBAT12V9AH**



**STAINLESS STEEL POST MOUNT BRACKET.** For solar panel. Easy installation to post 2" to 4" in diameter. Part no. **N999473**



**SECURITY BOLTS.** To be used on solar panel bracket. Once fixed and secured, makes the removal of the bolts virtually impossible. Great for theft prevention. Part no. **N999475**

## READ BEFORE INSTALLING

### PRODUCT PURCHASE AND INSTALLATION

This product is intended to only be installed by a qualified professional technician. The warranty on the equipment may be voided if not properly installed. Warranty claims should be directed to the company or entity that sold the equipment. Purchasing non-installed equipment may later hinder any warranty claim because of conflict between the equipment provider and the installer entity. It is highly recommended for the system to be supplied and installed by a single entity.

### SOLAR POWERED SYSTEM CONSIDERATIONS

The ECOSOL solar powered system is intended for residential applications and light commercial gate operation with limited cycles per day. While our system can operate over 300 cycles and/or provide over 2 weeks of standby time on fully charged batteries, it needs enough standby time to fully recharge the batteries or it will eventually run out of charge to operate the system. We highly recommend to keep the system as simple as possible and avoid adding accessories that draw current from the batteries. The ECOSOL interface board manages energy consumption and powers down all components, accessories and peripherals that are not required to operate while the gate is fully closed or after 5 minutes of inactivity. For optimum performance, we recommend the following setup:

- One or two actuators (Phobos BT or Igea BT) connected to the ECOSOL system.
- Two sets of photo-beam obstruction sensors.
- BFT radio transmitters and/or wireless keypads programmed to the ECOSOL's built-in low consumption receiver.
- Automatic closing timer enabled.

Anytime, additional accessories are added, it is suggested to increase the systems charging capacity by adding a solar panel. See page 15 for further information.

### EXISTING GATE CONDITION

Automation should be installed on a gate which is moving freely. Any issue with the smooth opening or closing of a gate will not be corrected by adding automation.

ACCESSORIES .....	02
SYSTEM RECOMMENDATIONS .....	03
INSTALLATION CHECKLIST .....	05
IMPORTANT SAFETY INFORMATION .....	06
UL325 INSTALLATION RECOMENDATIONS .....	07
INSTALLATION SAFETY .....	08
OPERATIONAL SAFETY .....	09
THE SYSTEM .....	10
INSTALLING THE ENCLOSURE .....	11
POSITIONING THE SOLAR PANEL .....	12
MOUNTING THE SOLAR PANEL .....	13
WIRING THE SOLAR PANEL .....	14
ADDING SOLAR PANELS .....	15
INSTALLING THE BATTERIES .....	16
MOTOR CONNECTIONS .....	23
SAFETY DEVICES .....	18
OPENING DEVICES .....	19
CONTROL WIRING .....	20
ECOSOL SETTINGS .....	21
LIBRA UL-R PROGRAMMING .....	22
MAIN MENU .....	23
PARAMETERS SUB-MENU .....	24
LOGIC SUB-MENU .....	25
INITIAL PROGRAMMING .....	26
COMMON OPTIONS .....	27
RADIO TRANSMITTERS .....	28
MAINTENACE .....	29
TROUBLESHOOTING .....	30
DISPLAY GLOSSARY .....	31

- CAREFULLY READ ALL SAFETY INFORMATION. Pages 6 - 9
- Install the gate operator(s) according to the installation manual (Book 1 of 2).
- Determine the best location for your solar panel. Page 12
- Secure ECOSOL enclosure to wall, column or post. Page 11.
- Determine the orientation and inclination of the solar panel and install it. Pages 12 & 13.
- Wire solar panel or panels to the ECOSOL system Pages 14 & 15.
- Install batteries. Page 16.
- Connect motor wires to the ECOSOL system. Page 23.
- Connect obstruction sensing devices. Page 18.
- Connect opening devices (if applicable). Page 19.
- Connect other control devices (if applicable) Page 20.
- Set the controller to SINGLE GATE OPERATION if needed. Page 26.
- Perform the AUTOSET. Page 26.
- Set other features if needed. Page 27.
- Adjust parameters if needed. Page 24.
- Program remote controls and/or wireless keypad(s). Page 28.
- Test all safety devices and features.

**GATE AUTOMATION INSTALLATION SAFETY**

While the manufacturer has designed the system under strict safety standards, it is ultimately the installers responsibility to follow and comply with national and local laws, codes and safety standards that apply to the mechanical, electrical and operational aspects of the gate automation system. These include but are not limited to: safety standards established by entities like Underwriters Laboratory (UL), NFPA 70, or codes and laws stated by corresponding state, county or municipality.

While it may not be compulsory, we highly recommend following UL 325 safety standards.

**UL 325 VEHICULAR GATE AUTOMATION CLASSIFICATION**

This system can be used in Class I, Class II and Class III applications.

- CLASS I - RESIDENTIAL VEHICULAR GATE OPERATOR - A vehicular gate operator (or system) intended for use in a home of one-to four single family dwelling, or a garage or parking area associated therewith.
- CLASS II - COMMERCIAL/GENERAL ACCESS VEHICULAR GATE OPERATOR - A vehicular gate operator (or system) intended for use in a commercial location or building such as a multi-family housing unit (five or more single family units), hotel, garages, retail store, or other building servicing the general public.
- CLASS III - INDUSTRIAL/LIMITED ACCESS VEHICULAR GATE OPERATOR - A vehicular gate operator (or system) intended for use in an industrial location or building such as a factory or loading dock area or other locations not intended to service the general public.
- CLASS IV - RESTRICTED ACCESS VEHICULAR GATE OPERATOR - A vehicular gate operator (or system) intended for use in a guarded industrial location or building such as an airport security area or other restricted access locations not servicing the general public, in which unauthorized access is prevented via supervision by security personnel.

**UL 325 ENTRAPMENT PROTECTION REQUIREMENTS**

For all installation classes, it is required to properly adjust the inherent obstruction sensing system (AUTOSET, page 26) and install warning signs on both sides of the gate, warning pedestrians of the dangers of the automated gate system. For Class I and Class II installations, it is required to add a non-contact device, such as a photoelectric eye **OR** a contact device such as a gate edge. For Class III installations it is required to add a non-contact device, such as a photoelectric eye, **AND** a contact device such as a gate edge **OR** an audio alarm such as a siren, horn or buzzer.

1. Install the gate operator only when:
  - a. The operator is appropriate for the construction and the usage class of the gate.
  - b. All openings of a horizontal slide gate are guarded or screened from the bottom of the gate to a minimum of 4' (1.2 m) above the ground to prevent a 2-1/4" (6 cm) diameter sphere from passing through the openings anywhere in the gate, and in that portion of the adjacent fence that the gate covers in the open position.
  - c. All exposed pinch points are eliminated or guarded, and guarding is supplied for exposed rollers.
2. The operator is intended for installation only on gates used for vehicles. Pedestrians must be supplied with a separate access opening. The pedestrian access opening shall be designed to promote pedestrian usage. Locate the gate such that persons will not come in contact with the vehicular gate during the entire path of travel of the vehicular gate.
3. The gate must be installed in a location so that enough clearance is supplied between the gate and adjacent structures when opening and closing to reduce the risk of entrapment. Swinging gates shall not open into public access areas.
4. The gate must be properly installed and work freely in both directions prior to the installation of the gate operator.
5. Controls intended for user activation must be located at least six feet (6') away from any moving part of the gate and where the user is prevented from reaching over, under, around or through the gate to operate the controls. Outdoor or easily accessible controls shall have a security feature to prevent unauthorized use.
6. The Stop and/or Reset (if provided separately) must be located in the line-of-sight of the gate. Activation of the reset control shall not cause the operator to start.
7. A minimum of two (2) WARNING SIGNS (supplied with the gate operator) shall be installed, one on each side of the gate where easily visible.
8. For a gate operator utilizing a non-contact sensor:
  - a. Reference owner's manual regarding placement of non-contact sensor for each type of application.
  - b. Care shall be exercised to reduce the risk of nuisance tripping, such as when a vehicle trips the sensor while the gate is still moving.
  - c. One or more non-contact sensors shall be located where the risk of entrapment or obstruction exists, such as the perimeter reachable by a moving gate or barrier.
9. For a gate operator utilizing a contact sensor such as an edge sensor:
  - a. One or more contact sensors shall be located where the risk of entrapment or obstruction exists, such as at the leading edge, trailing edge and post mounted both inside and outside of a vehicular horizontal slide gate.
  - b. One or more contact sensors shall be located at the bottom edge of a vehicular vertical lift gate.
  - c. A hard wired contact sensor shall be located and its wiring arranged so the communication between the sensor and the gate operator is not subject to mechanical damage.
  - d. A wireless contact sensor such as the one that transmits radio frequency (RF) signals to the gate operator for entrapment protection functions shall be located where the transmission of the signals are not obstructed or impeded by building structures, natural landscaping or similar obstruction. A wireless contact sensor shall function under the intended end-use conditions.
  - e. One or more contact sensors shall be located on the inside and outside leading edge of a swing gate. Additionally, if the bottom edge of a swing gate is greater than 6" (152 mm) above the ground at any point in its arc of travel, one or more contact sensors shall be located on the bottom edge.
  - f. One or more contact sensors shall be located at the bottom edge of a vertical barrier (arm).

**GENERAL SAFETY**

**WARNING!** An incorrect installation or improper use of the product can cause damage to persons, animals or property.

- Automation should be installed on a gate which is moving freely. Any issue with the smooth opening or closing of a gate will not be corrected by adding automation.
- Scrap packing materials (plastic, cardboard, polystyrene etc) according to the provisions set out by current standards. Keep nylon or polystyrene bags out of children's reach.
- Keep this instruction manual for future reference.
- This product was exclusively designed and manufactured for the use specified in the present documentation. Any other use not specified in this documentation could damage the product and be dangerous.
- The Company declines all responsibility for any consequences resulting from improper use of the product, or use which is different from that expected and specified in the present documentation.
- Do not install the product in explosive atmosphere.
- The Company declines all responsibility for any consequences resulting from failure to observe Good Technical Practice when constructing closing structures (door, gates etc.), as well as from any deformation which might occur during use.
- Follow and comply with national and/or local electrical codes when performing any electrical installation.
- Disconnect the electrical power supply before carrying out any work on the installation. Also disconnect any buffer batteries, if fitted.
- Fit all the safety devices (photocells, electric edges etc.) which are needed to protect the area from any danger caused by squashing, conveying and shearing, according to and in compliance with the applicable directives and technical standards.
- It is recommended to position at least one luminous signal indication device (blinker) where it can be easily seen for additional safety
- The Company declines all responsibility with respect to the automation safety and correct operation when other manufacturer's components are used.
- Only use original parts for any maintenance or repair operation.
- Do not modify the automation components, unless explicitly authorized in writing by the Company.
- Instruct the product user about the control systems provided and the manual opening operation in case of emergency.
- Anything which is not expressly provided for in the present instructions, is not allowed.
- Installation must be carried out using the safety devices and controls prescribed by the UL 325 Standard.

**CHECKING INSTALLATION**

Before the automated device is finally put into operation, perform the following checks meticulously:

- Make sure all components are fastened securely.
- Check that all safety devices (photocells, pneumatic safety edge, etc.) are working properly.
- Check the emergency operation control device.
- Check opening and closing operations with the control devices applied.
- Check the electronic logic for normal (or personalized) operation in the control panel.

**ADJUSTING OPERATING FORCE**

**WARNING:** Operating force is adjusted with extreme precision by means of the control unit's electronic control. Operation at the end of travel is adjusted electronically in the control panel. To provide good anti-crush safety, the operating force must be slightly greater than that required to move the leaf both to close and to open it.

**CONTROL**

There are various options when it comes to the control system (manual, remote control, access control with magnetic badge, etc.) depending on the installation's needs and characteristics. See the relevant instructions for the various control system options. People due to use the automated device must be instructed how to control and use it.



**The installer is responsible for communicating the following information to the end-user:**

This product has been designed and built solely for the purpose indicated herein. Uses not contemplated herein might result in the product being damaged and could be a source of danger.

The Firm disclaims all responsibility resulting from improper use or any use other than that for which the product has been designed, as indicated herein, as well as for failure to apply Good Practice in the construction of entry systems (doors, gates, etc.) and for deformation that could occur during use. If installed and used correctly, the automated system will meet the required level of safety. Nonetheless, **it is advisable to observe certain rules of behavior so that accidental problems can be avoided:**

- Keep adults, children and property out of range of the automated system, especially while it is operating.
- Operate the system when the full path of the gate is within sight.
- It is essential to frequently check that all safety devices are in good working condition.
- This application is not meant for use by people (including children) with impaired mental, physical or sensory capacities, or people who do not have suitable knowledge, unless they are supervised or have been instructed by people who are responsible for their safety.
- Children must be supervised to ensure they do not play with the system. Keep remote controls or other control devices out of reach of children in order to avoid the automated system being operated inadvertently.
- Check the system frequently, especially hinges, cables, springs or supports, to detect any loss of balance and signs of wear or damage.
- When cleaning the outside or performing other maintenance work, always cut off mains power.
- Keep the photocells' optics and illuminating indicator devices clean. Check that no branches or shrubs interfere with the safety devices (photocells).
- Do not use the automated system if it is in need of repair. In the event of a malfunction, cut off the power, activate the emergency release to allow access and call in qualified technical personnel (professional installer).
- If the automated system requires work of any kind, employ the services of qualified personnel (professional installer).
- Anything that is not explicitly provided for in these instructions is not allowed.
- The operator's proper operation can only be guaranteed if the information given herein is complied with. The Firm shall not be answerable for damage caused by failure to comply with the installation rules and instructions featured herein.
- Have the complete system checked including all safety devices by a qualified professional technician at least once a year.

Descriptions and illustrations herein are not binding. While we will not alter the product's essential features, the Firm reserves the right, at any time, to make those changes deemed necessary to improve the product from a technical, design or commercial point of view, and will not be required to update this publication accordingly.

**ECOSOL INTERFACE BOARD**

- Regulates the power from the solar panel(s)
- Monitors battery charge
- Charges batteries
- Manages power. Shuts down all components not needed when system is not in use
- Processes starting commands. Powers up the system and relays signals once system is operational
- Receives radio commands. Has a built-in low power consumption radio receiver with a 64 transmitters capacity, eliminating the need for external receivers

**LIBRA UL-R CONTROLLER**

- Controls (2) Phobos BT or Igea BT operators.
- Self learning torque settings.
- Adjustable independent gate leaf delay

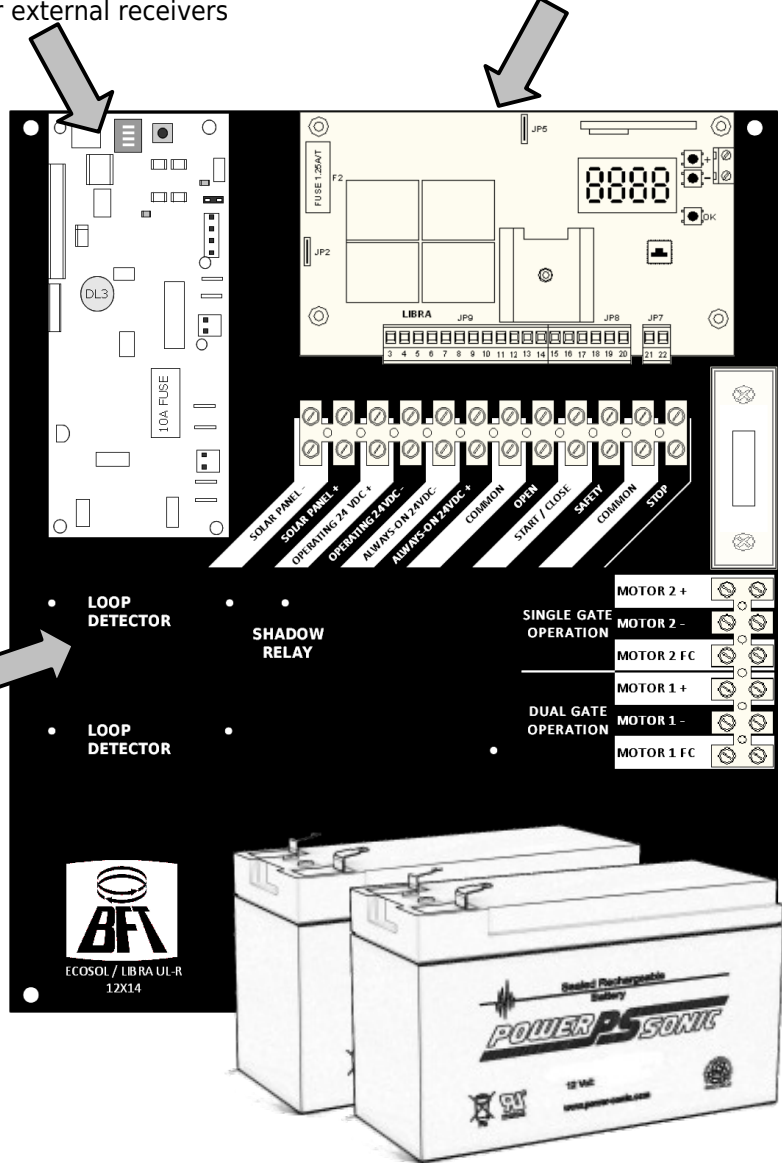

**TEST BUTTON**

Triggers the START input for the installer's and service technician's convenience.

**THREADED HOLES**

For the installation of (2) Diablo Controls DSP-6LP or DSP-7LP

**TERMINAL BLOCKS**

Clearly labeled, easy access terminal block connections

**(2) 12V, 9 Ah batteries**

30% more capacity than standard 7 Ah batteries

## ENCLOSURE LOCATION

Because the maximum length of the cable that connects the solar panel and the ECOSOL enclosure is limited to 15 feet, it is more important that the final location of the enclosure is close to the location of the solar panel than to the location of the gate operators.

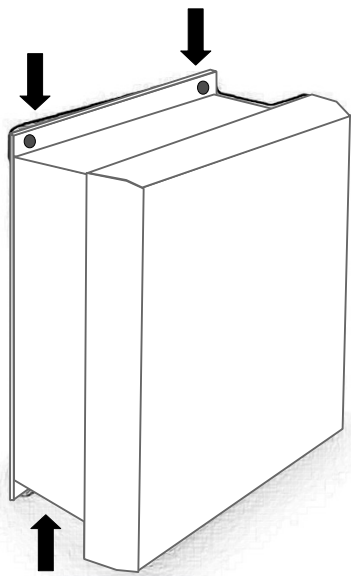
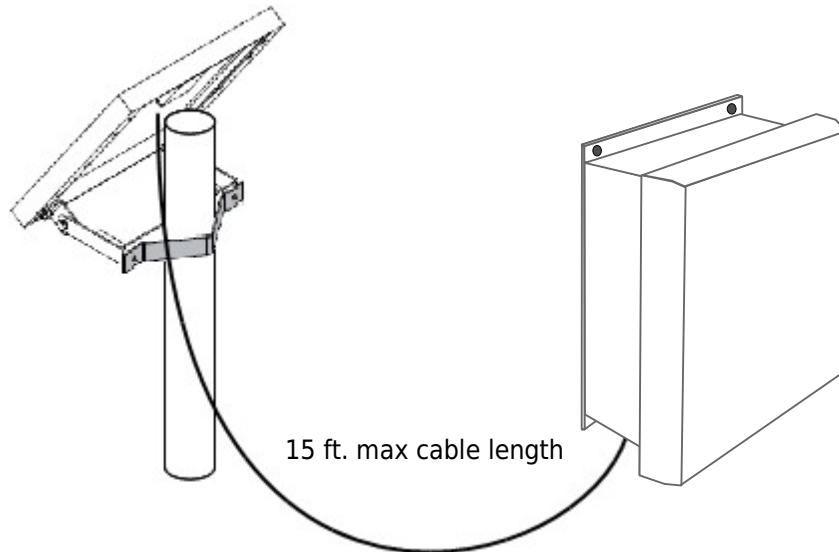

## ATTACHING THE ENCLOSURE

Fasten the ECOSOL enclosure to a wall, column or post using the 4 mounting holes on the flange on the back of the enclosure. **DO NOT DRILL THROUGH THE INTERIOR OF THE ENCLOSURE.**

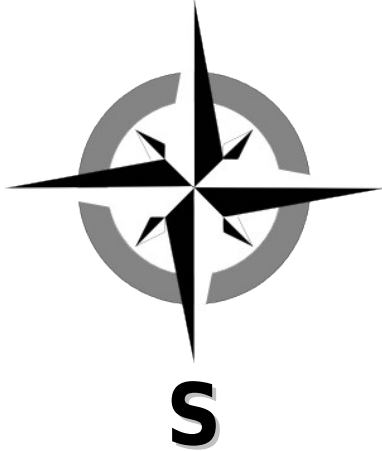

Solar panel **MUST FACE SOUTH**

**SOLAR PANEL LOCATION** - The solar panel must be located on a unshaded area away from trees and/or tall structures that may cast a shadow during any time of the day or year. It is extremely important to be aware that the sun has a lower path in the sky during the winter months and objects that may not cast shadows over a certain area during summer, may cast them during the winter. Also, trees may grow and cast larger shadows over time.

**SOLAR PANEL INCLINATION** - The degrees of inclination in reference to ground level should be set according to your location and the illustration below. **Example:** If installed in the state of Georgia, the panel must have a 40° inclination. If installed in Wyoming the panel must have a 50° inclination.

### DEGREES OF INCLINATION

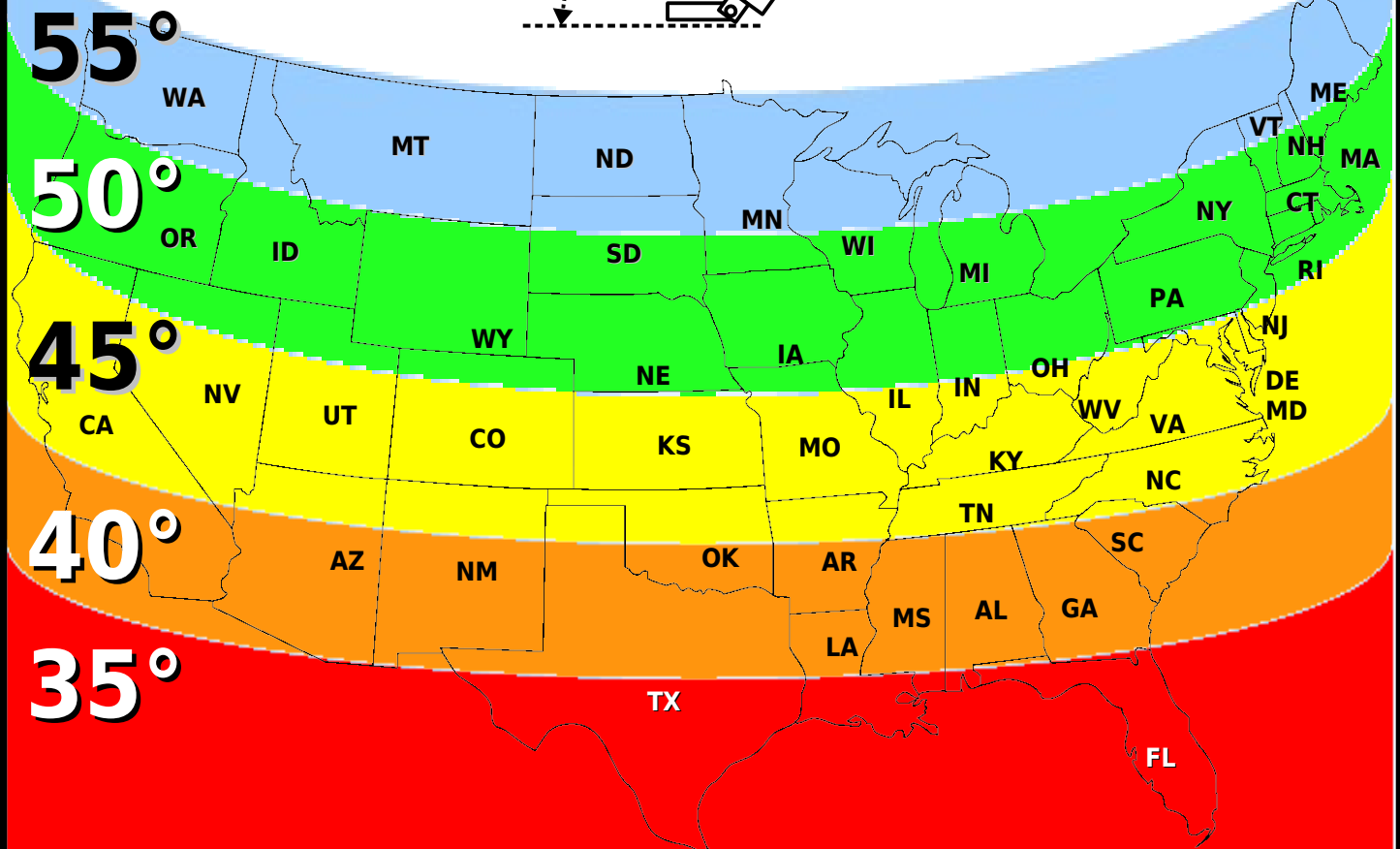
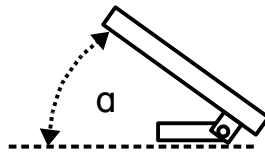

#### OTHER COUNTRIES:

30° Mexico, Jamaica, La Espalier, Puerto Rico, U.S. and British Virgin Islands.



25° Guatemala, Honduras, El Salvador.

20° Nicaragua, Costa Rica, Panama.

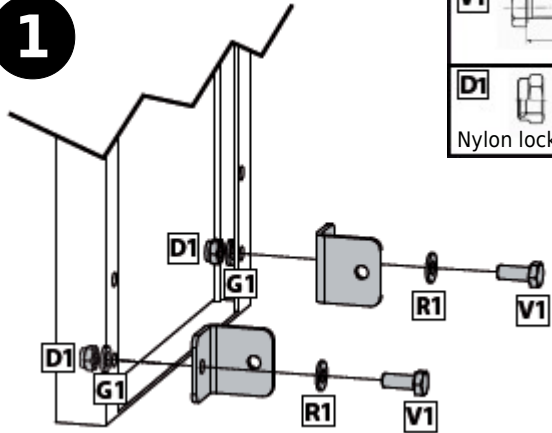
**1**

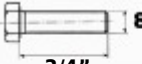

Secure "L" brackets to panel's frame

<b>V1</b>	 3/4" Bolt	<b>R1</b>	Flat washer
<b>D1</b>	 Nylon lock nut 8	<b>G1</b>	Pressure washer

**2**

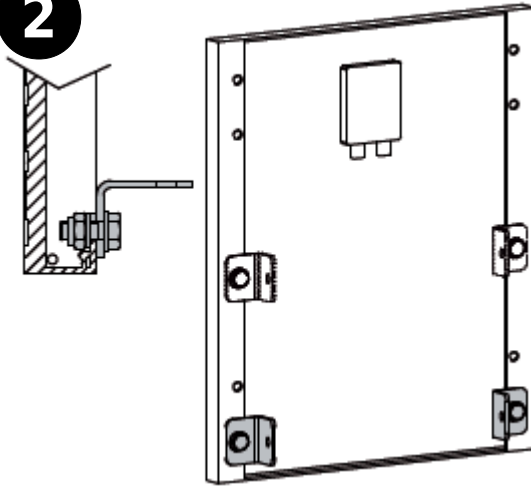

Brackets can be attached at different heights on the panel to accommodate different installation conditions

**3**

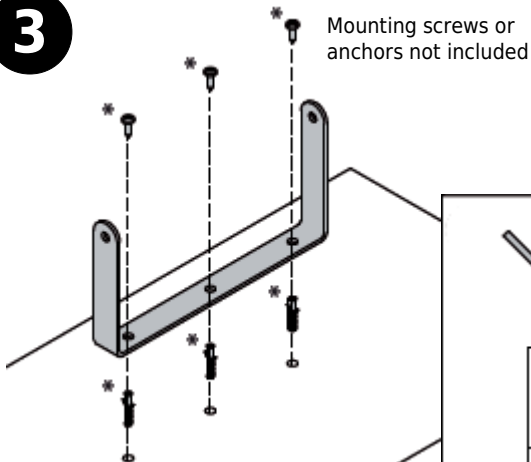

Mounting screws or anchors not included

Attach mounting bracket to mounting surface. The hardware allows for wall mount or top mount installation

**4**

Attach the panel to the mounting bracket

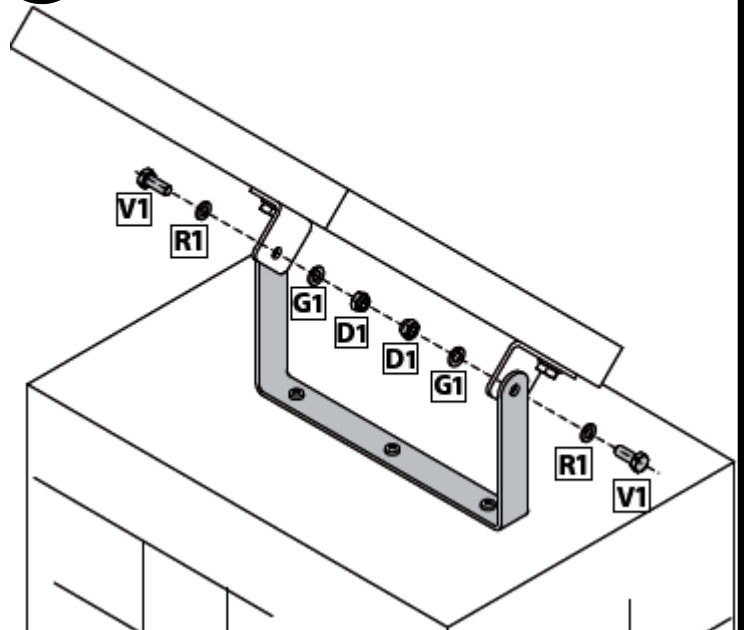

**Optional** stainless steel adjustable post mount bracket is available. Part no. **N999473**

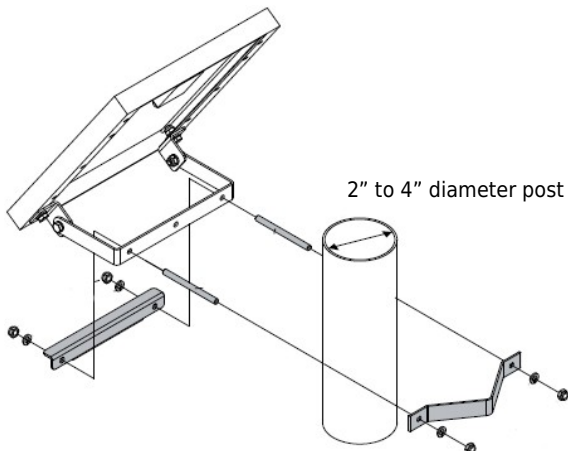

2" to 4" diameter post

# 1 CONNECT CABLE TO SOLAR PANEL

USE 16 AWG OR BETTER, STRANDED WIRES

- Remove the 4 screws that hold the cover to the solar panel terminal block.
- Run the cable through (1) of the connector fittings.
- Connect the black wire to the left (negative) terminal and the red wire to the right (positive) terminal.

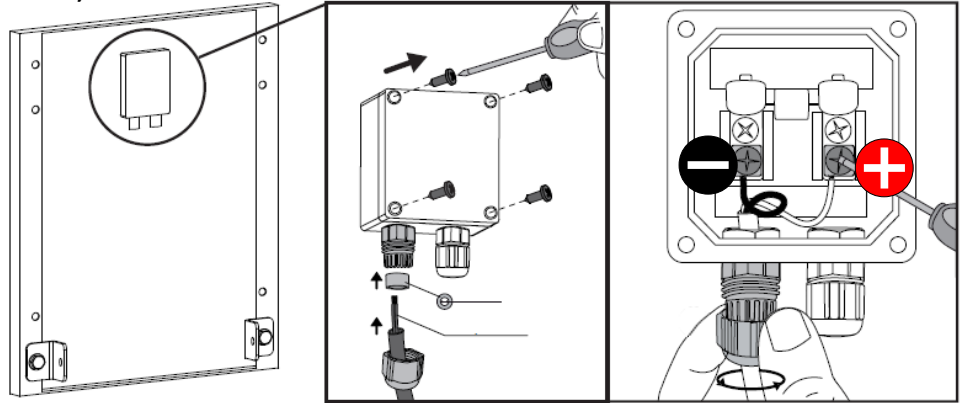

# 2 RUN THE CABLE TO THE ECOSOL ENCLOSURE

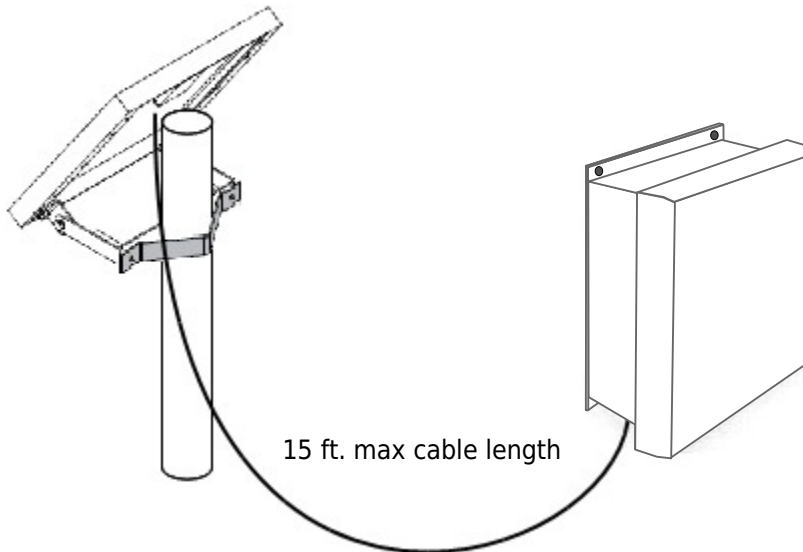

# 3 CONNECT CABLE TO TERMINAL STRIP

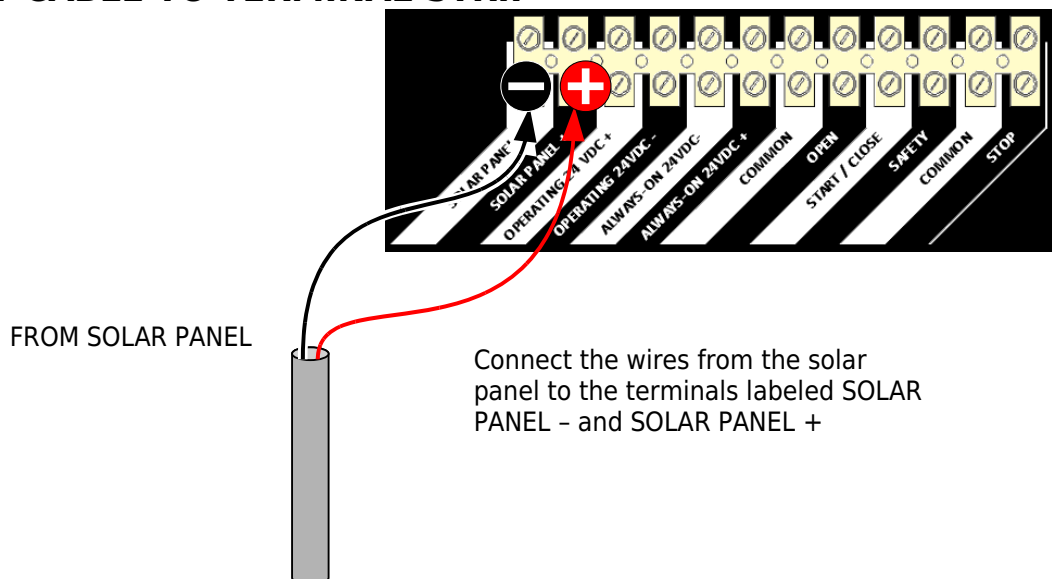

**Up to (3) 10 watts, 24v panels can be connected to the ECOSOL.**  
(35W maximum total capacity)

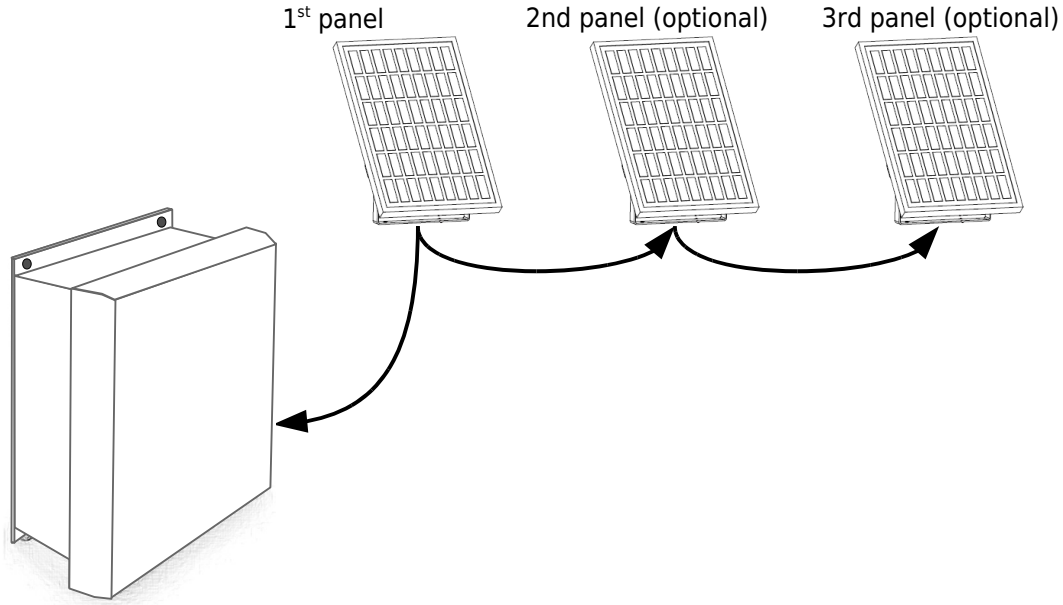

## KEEP THE CABLES AS SHORT AS POSSIBLE!!

The wires should be stranded 16 AWG or better and no longer than 15ft.

The solar panels must be connected in a parallel daisy chain where the black wires will only be connected to the negative terminal and the red wire will only be connected to the positive terminal on the solar panels.

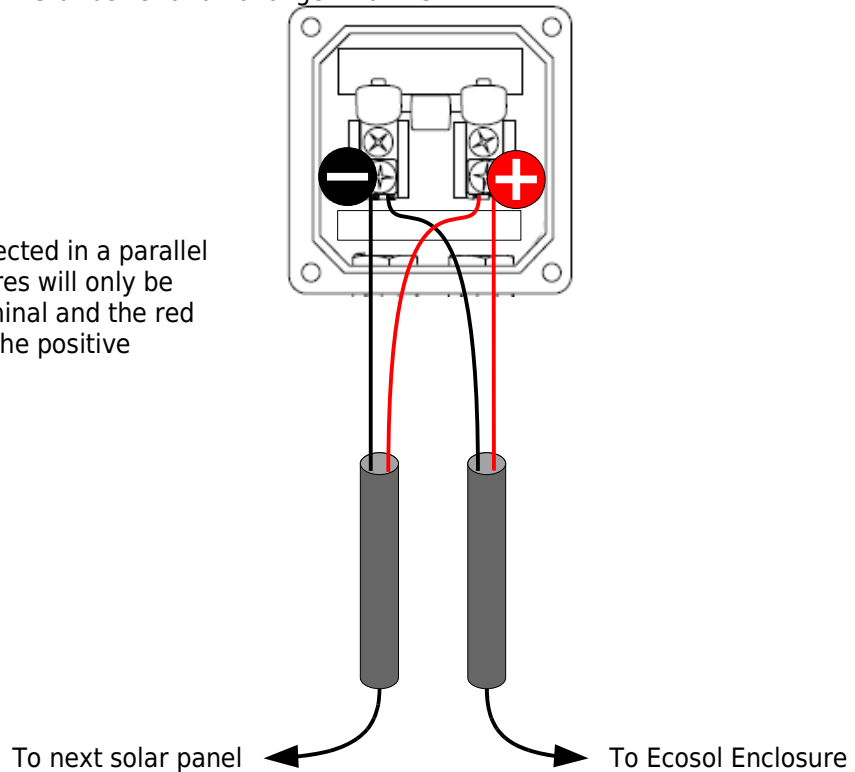

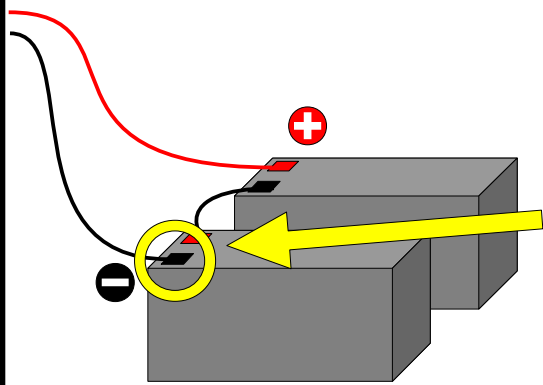

### POWER UP

The ECOSOL /Libra is shipped with the batteries leads pre-installed. The negative (black) lead is not connected to prevent discharge before installation. To power up the system, connect the black lead to the negative battery terminal

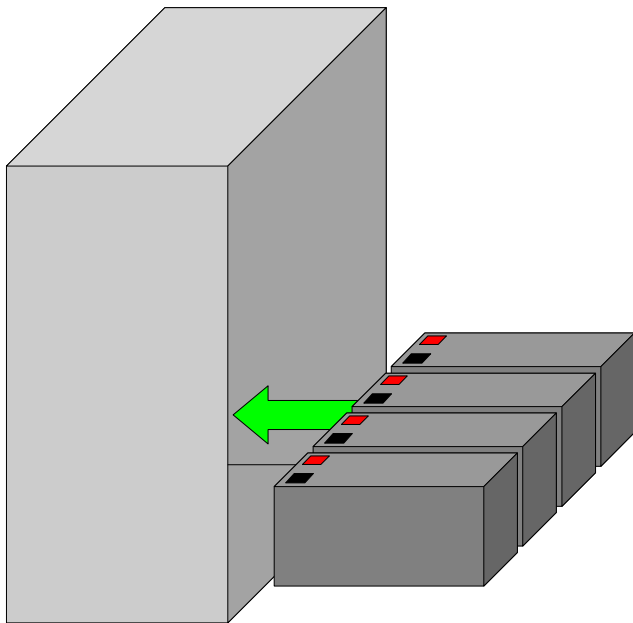

### ADDING MORE BATTERIES

The ECOSOL/Libra enclosure can hold up to (2) pairs (4 total) batteries for greater energy storage capacity. The battery brackets must be removed and the batteries must be rotated longways in order to fit them inside the enclosure.

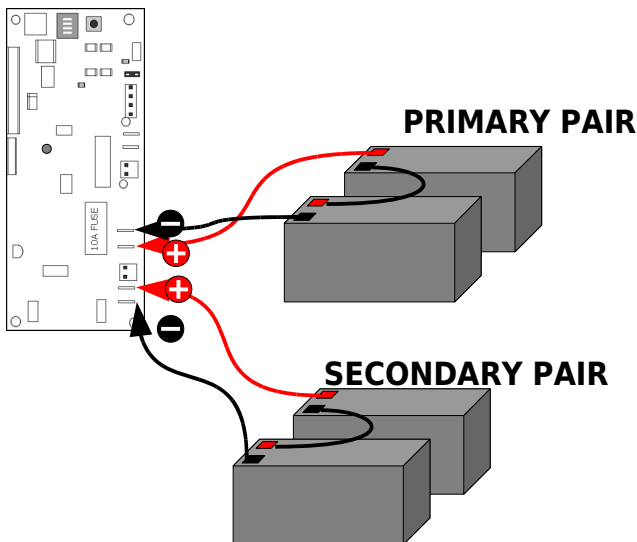

## WARNING

### When adding batteries...

- **Install (4) new batteries** - Never mix used and new batteries
- **Make sure they have the same rating** - Batteries may have the same physical size but have different characteristics (volts and ampere-hours)
- **Equalize the charge** - all 4 batteries must be within 0.7 volts of each other. An easy way of accomplishing this is by fully charging them individually before installing.
- **Connect to ECOSOL** - The primary pair of batteries must be connected to **JP15(-)** and **JP16(+)** while the secondary pair must be connected to **JP23(+)** and **JP18(-)**.
- **Dipswitch 1** on the ECOSOL board **MUST be turned on** when secondary pair of batteries are connected



## SINGLE GATE OPERATION

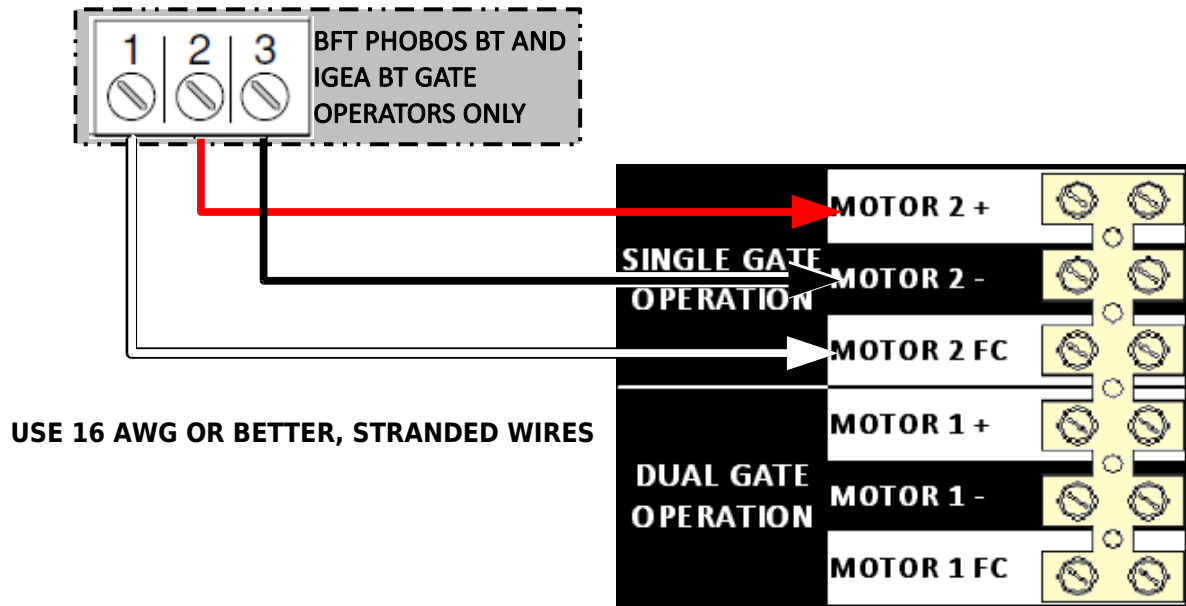

When installing a single leaf gate operator, the motor leads must be wired to MOTOR 2 terminals and LIBRA controller must be configured to single gate operation. Please refer to page 26 for further instructions.

## DUAL GATE OPERATION

When installing **dual gate** where the gates **overlap** (or has a lock mechanism), it is important that the **motor that needs to open first is wired to MOTOR 2** terminals.

During the **open cycle, MOTOR 2 starts first** (MOTOR 1 has a delayed open start). During the close cycle, MOTOR 1 starts first (MOTOR 2 has a delayed close start). Both delays can be independently adjusted from 1 to 29 seconds. Please refer to page 24 for further instructions.

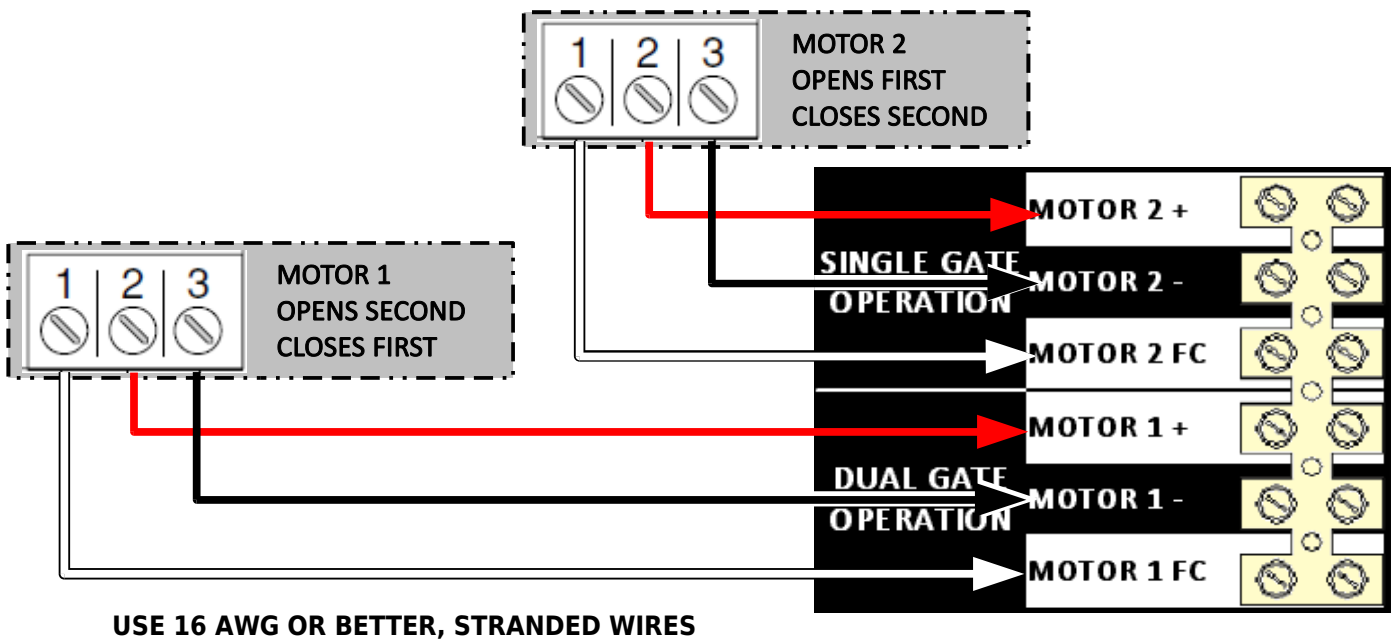

## PHOTO BEAM AND SAFETY EDGE SENSORS

Photo-beam sensors should only be used as safety devices, **NEVER** as free exit devices.

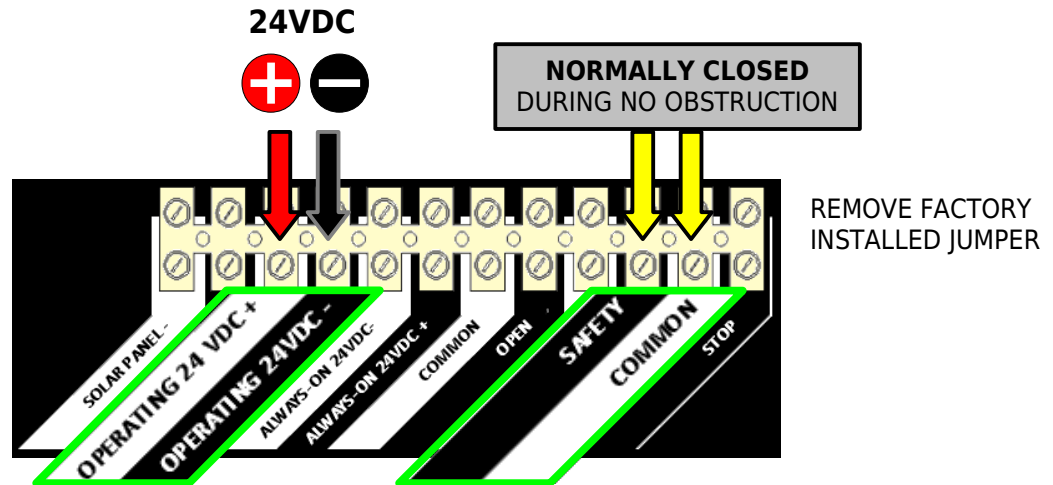

## MAGNETIC LOOP DETECTORS

Loop detectors must **ALWAYS BE POWERED** to ensure proper detection.

Avoid the utilization of loop detectors. They decrease the standby time as well as the cycles per day. They also increase the battery charge time. If loop detectors are a must in your installation, look for low power consumption loop detectors such as **Diablo Controls** models **DSP-6LP** and **DSP-7LP**. **ADDING AN ADDITIONAL SOLAR PANEL IS RECOMMENDED.**

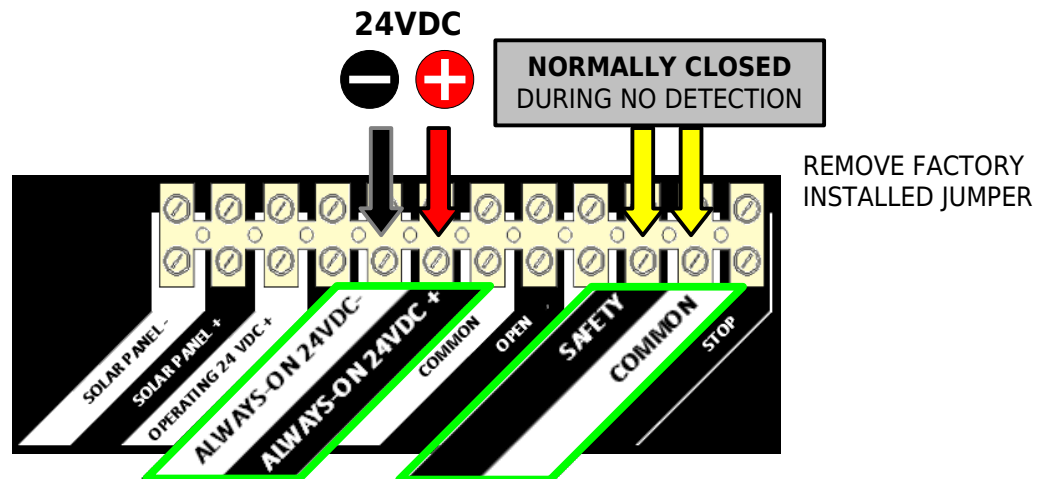

## MULTIPLE SAFETY DEVICES



**NOTE:** If more than one device needs to be wired to the Safety input, they must be wired in series

## WIRELESS

The ECOSOL system has a built-in, low power consumption, radio receiver for BFT remote controls and wireless keypads. Any additional opening device powered off the system will decrease the system's battery performance



**MITTO 2**

2 button remote control



**MITTO 4**

4 button remote control



**T-BOX**

Battery operated wireless keypad

SEE PAGE 28 FOR PROGRAMMING INSTRUCTIONS

## HARD WIRED

Avoid the utilization of external opening devices that require to be powered off the ECOSOL system. They decrease the standby time as well as the cycles per day capacity. They also increase the battery charge time. If a "free exit" device is a must in your installation, look for low power consumption loop detectors such as **Diablo Controls** models **DSP-6LP** and **DSP-7LP** or other low consumption devices. **ADDING AN ADDITIONAL SOLAR PANEL IS RECOMMENDED.**

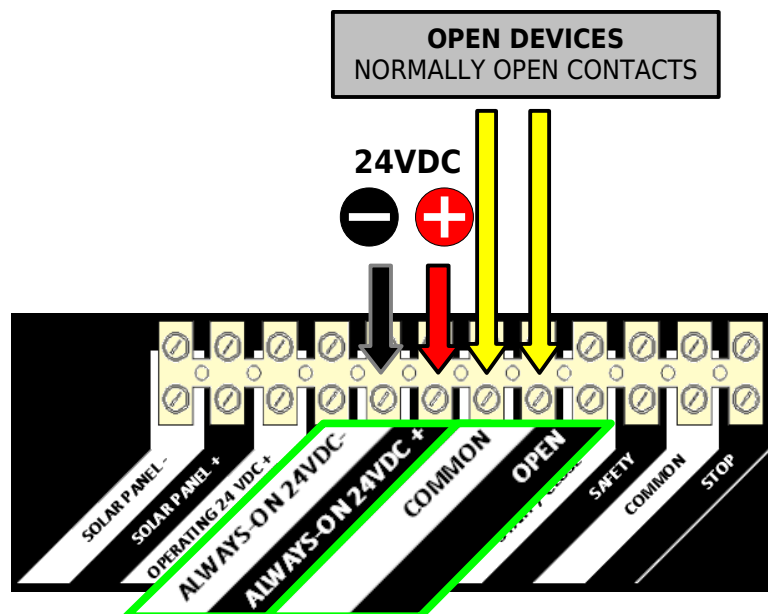

### START / CLOSE INPUT

The Start/Close input can be used for a single push button operation to open, stop and close commands

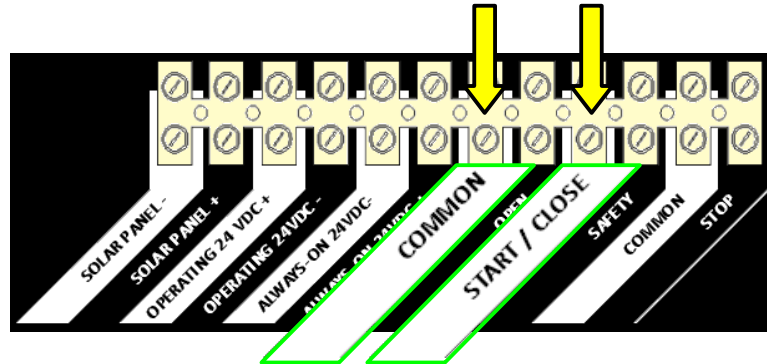

### STOP / RESET BUTTON

The Stop button also resets the controller if two consecutive physical obstructions are detected. This is a **NORMALLY CLOSED** contact. The factory installed jumper must be removed for stop button to operate.

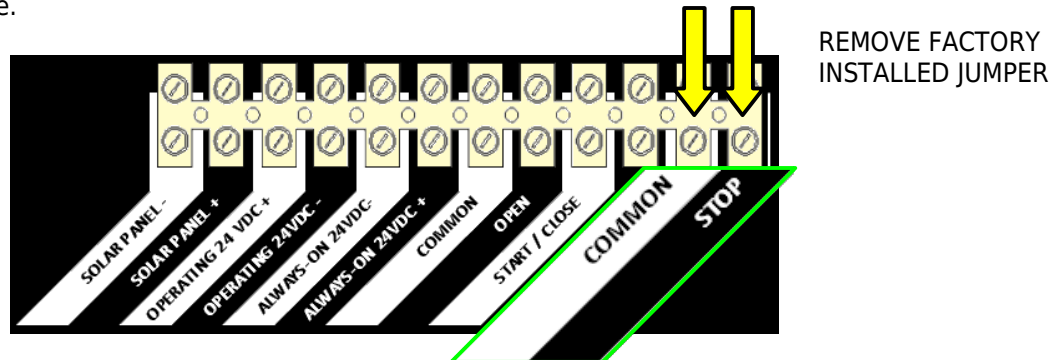

REMOVE FACTORY  
INSTALLED JUMPER



**NOTE:** If more than one device needs to be wired to the STOP input, they must be wired in series

### 3-BUTTON STATION (open, stop, close)

A 3-button station can be hard-wired using the START/CLOSE as close input. This input must be defined as CLOSE ONLY INPUT at the controller. See page 25 (START-CLOSE) for directions.

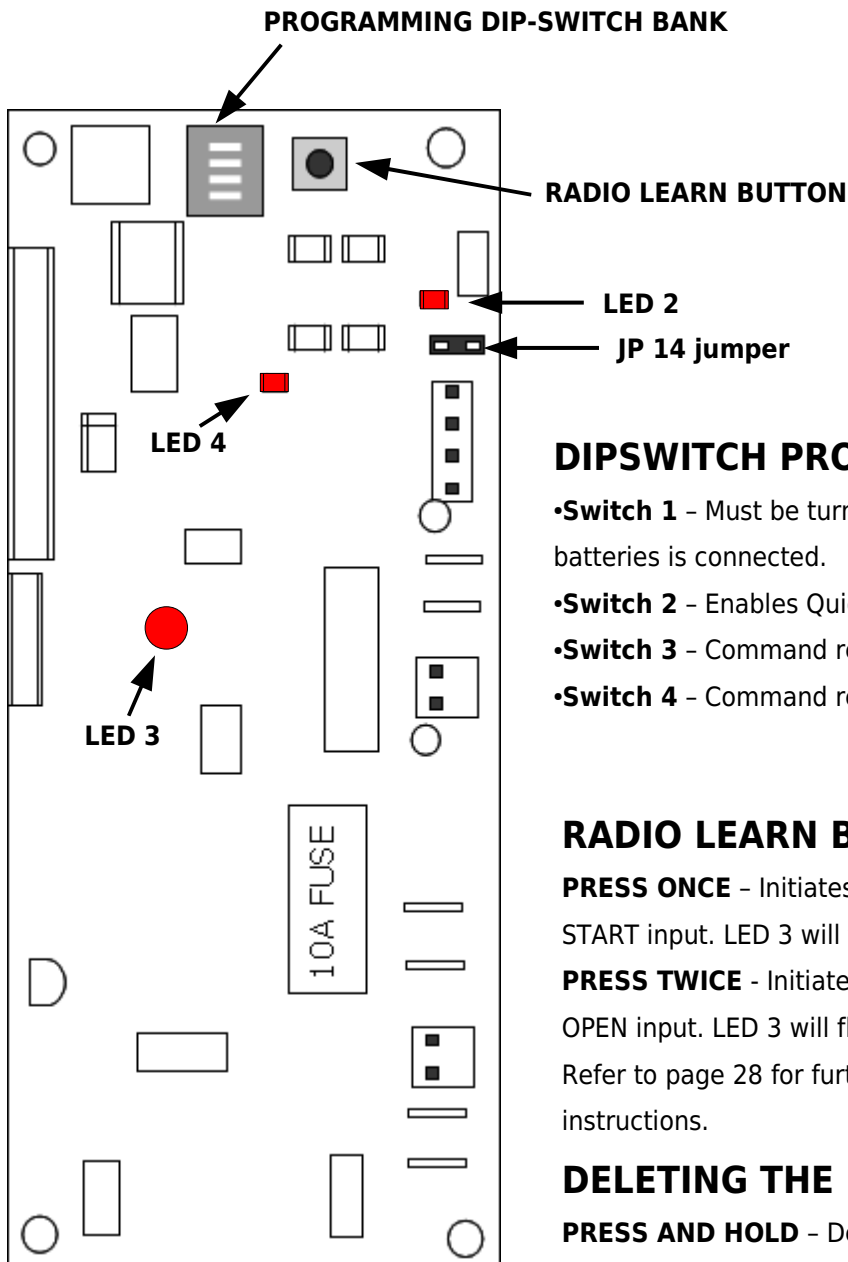

### DIPSWITCH PROGRAMMING

- **Switch 1** - Must be turned on ONLY when secondary pair of batteries is connected.
- **Switch 2** - Enables Quick Radio Programming
- **Switch 3** - Command relay delay (MUST BE TURNED ON)
- **Switch 4** - Command relay delay

### RADIO LEARN BUTTON

**PRESS ONCE** - Initiates process of learning transmitters as START input. LED 3 will flash @ 1/sec.

**PRESS TWICE** - Initiates process of learning transmitters as OPEN input. LED 3 will flash @ 2/sec.

Refer to page 28 for further transmitter programming instructions.

### DELETING THE MEMORY

**PRESS AND HOLD** - Deletes all transmitters from memory. LED 3 will blink rapidly, then on steady.

Once it turns off, release the RADIO LEARN BUTTON.

### LED LEGEND

**LED2** - Libra programming jumper (JP14) on indicator

**LED3** - (1 flash/sec) Learning transmitter as START input.

(2 flashes/sec) Learning transmitter as OPEN input.

(Steady) Hidden button learned.

(3 flashes) Low battery (below 24V)

**LED4** - Charging batteries

## POWER UP THE CONTROLLER

Install the jumper provided on both pins labeled JP14 on the Ecosol interface board. As long as this jumper is in place the Libra UL-R will be powered for the programming process

**REMOVE JUMPER UPON PROGRAMMING COMPLETION**  
Failure to do so will result in rapid battery discharge

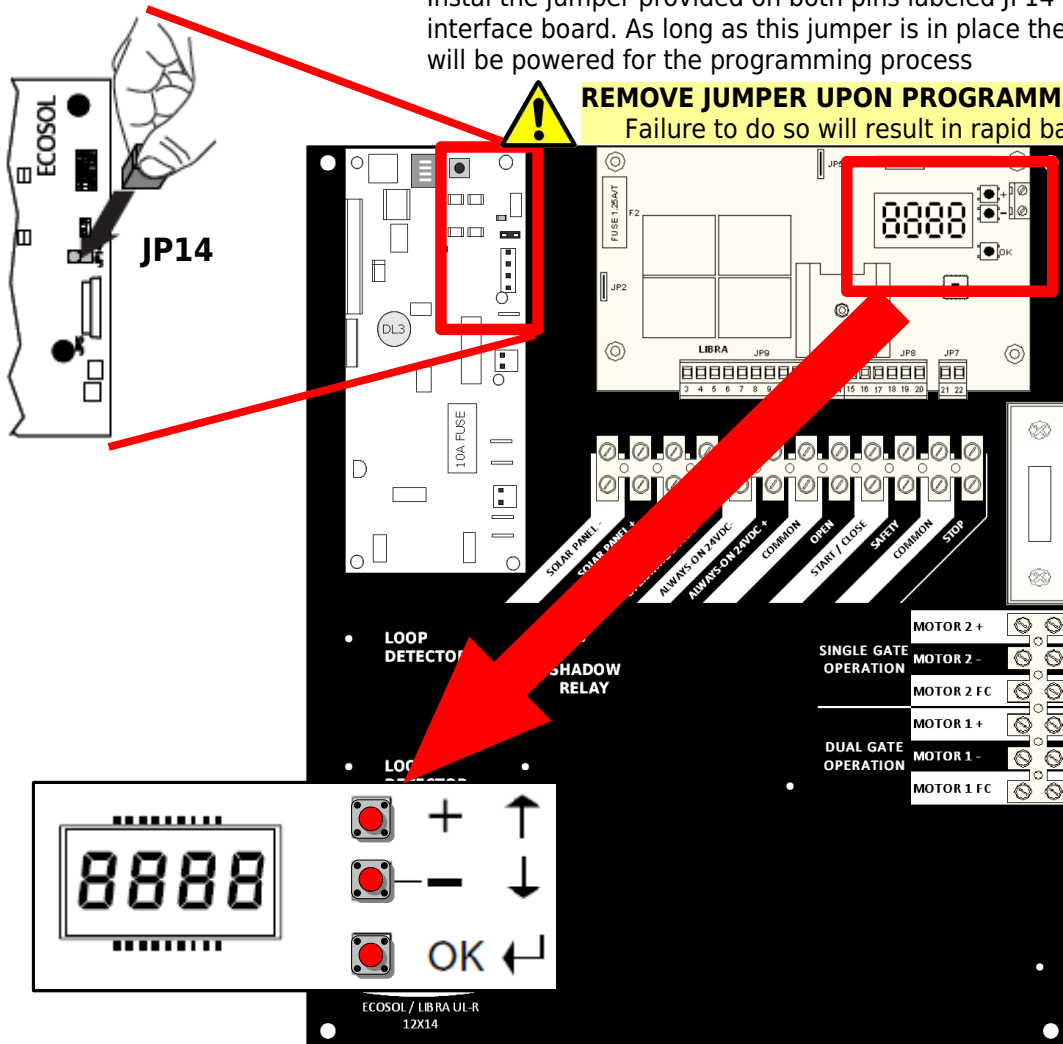

## NAVIGATE THE PROGRAMMING MENU

Use the LCD display and the 3 buttons on the upper right corner of the Libra UL-R to navigate and manipulate the menu.

PRESS  **OK 2 TIMES** TO ENTER THE MAIN PROGRAMMING MENU

USE THE  **+** AND  **-** BUTTONS TO SCROLL UP AND DOWN THE MENU

USE THE  **OK** BUTTON AS "ENTER" TO SELECT A MENU CHOICE OR CONFIRM A PROGRAMMING ORDER

PRESS  **+** AND  **-** **AT THE SAME TIME** TO EXIT PROGRAMMING

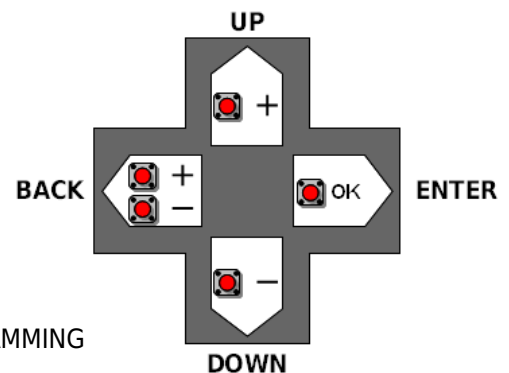

The main menu has 6 options. Of these 6, the first 3 are sub-menus (PARAMETERS, LOGIC, RADIO). Because the transmitters are programmed to the ECOSOL interface board, **the RADIO sub-menu MUST NOT BE USED!**

USE THE  **+** AND  **-** BUTTONS TO SCROLL UP AND DOWN THE MENU

USE THE  **OK** BUTTON AS “ENTER” TO SELECT A MENU CHOICE OR CONFIRM A PROGRAMMING ORDER

## DISPLAY

## DESCRIPTION

PARAM

**PARAMETERS** - Sub-menu where times and percentages are set (torque settings, run times, timer to close). See page 24.

LOGIC

**LOGIC** - Sub-menu where features are enabled or disabled. See page 25.

RADIO

**RADIO** - Sub-menu where wireless devices **DO NOT USE WITH ECOSOL** etc.) are programmed or deleted.

LANGUAGE

**LANGUAGE** - Menu area where the selection of the menu language is made

DEFAULT

**DEFAULT** - By selecting this menu option, the control board restores all its factory settings and changes language to Italian. The RADIO area remains unchanged.

AUTOSET

**AUTOSET** - By selecting this menu option, the actuators will automatically open and close at full torque and will self adjust its torque settings according to the gate weight. The operator's **limit switches must be set and the gates must be in the fully closed position prior to performing the AUTOSET.** Please refer to the operator's manual for proper limit switch setting procedure.

PRESS  **+** AND  **-** **AT THE SAME TIME** TO EXIT PROGRAMMING

## WHILE IN THE SUB-MENU

Navigation of the sub-menu is the same as the main menu. Once a sub-menu selection has been made:

USE THE  + AND  - INCREASE OR DECREASE THE PARAMETER VALUE



USE THE  OK BUTTON AS "ENTER" TO CONFIRM THE DESIRED VALUE

PRESS  + AND  - **AT THE SAME TIME** TO RETURN TO THE MAIN MENU

## PARAMETER OPTIONS

### DISPLAY

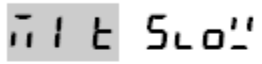
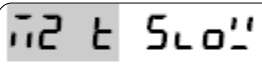
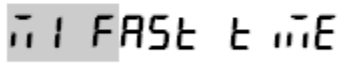
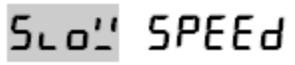

### DESCRIPTION

	• TCA - <b>Auto Close Timer</b> . Range: 3-60 seconds. Default: 10
	• M1 T - <b>Motor 1 Torque</b> . Range: 1-99%. Default: 50
	• M2 T - <b>Motor 2 Torque</b> . Range: 1-99%. Default: 50
	• M1 T SLOW - <b>Motor 1 Slowdown Torque</b> <b>NO EFFECT WITH ECOSOL</b>
	• M2 T SLOW - <b>Motor 2 Slowdown Torque</b> <b>NO EFFECT WITH ECOSOL</b>
	• OPEN DELAY TIME - <b>Motor 1 open delay</b> . Range: 1.0-10 seconds. Default: 1.0
	• CLS DELAY TIME - <b>Motor 2 close delay</b> . Range: 1.0-10 seconds. Default: 1.0
	• M1 FAST TIME - Motor 1 full speed run time <b>NO EFFECT WITH ECOSOL</b> Default: 15.0
	• M2 FAST TIME - Motor 2 full speed run time <b>NO EFFECT WITH ECOSOL</b> Default: 15.0
	• SLOW SPEED - Slowdown speed. Range: 0 <b>NO EFFECT WITH ECOSOL</b> Default: 0
	• ZONE - <b>NOT USED</b>



## WHILE IN THE SUB-MENU

Navigation of the sub-menu is the same as the main menu. Once a sub-menu selection has been made:

USE  + TO TURN ON AND  - TO TURN OFF THE SELECTED FEATURE.

USE THE  OK BUTTON AS "ENTER" TO CONFIRM THE DESIRED VALUE

PRESS  + AND  - **AT THE SAME TIME** TO RETURN TO THE MAIN MENU

## LOGIC OPTIONS

### DISPLAY

### DESCRIPTION

t c A

• TCA - **Auto Close Timer**. Default: OFF

3 STEP

• 3 STEP - **Instant reverse**. Gate instantly reverses on START activation during the CLOSE cycle as opposed to stopping and requiring a 2<sup>nd</sup> START input for re-opening. Default: OFF

ibl oPEn

• IBL OPEN - **Ignore START input during OPEN cycle** . Default: OFF

FAST cLS

• FAST CLS - **Gate closes immediately after SAFETY input is cleared**. Default: OFF

Photoc oPEn

• PHOTOC OPEN - **Ignore SAFETY input during OPEN cycle**. If OFF, gate stops on SAFETY input activation during the OPEN cycle. Default: OFF

tEST Phot

• TEST PHOT - Enables the SAFETY input supervision **DO NOT USE WITH ECOSOL**

1 mot on

• 1 MOT ON - **Single gate operation**. Ignores MOTOR 1. Default: OFF

bloc PERSIST

• BLOC PERSIST - **Operator pushes for 0.5 seconds after CLOSE limit is reached**. PHYSICAL GATE STOP IS REQUIRED. Default: OFF

START-CLOSE

• START-CLOSE - **Converts START/CLOSE input into CLOSE ONLY input**. Default: OFF

FIXED code

• FIXED CODE - Disables the receiver's rolling code f **NO EFFECT WITH ECOSOL**



radio Prog



• RADIO PROG - Enables Quick Remote Programming **NO EFFECT WITH ECOSOL**



MASTER

• MASTER - **NOT USED**. Default: OFF



### THE PROGRAMMING MAIN MENU



Press the  OK button **twice** to enter the programming MAIN MENU 

Use the  + and  - buttons to navigate up or down the MAIN MENU

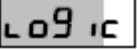

Press the  + and  - buttons AT THE **SAME TIME** to exit programming 

### SINGLE MOTOR OPERATION

From the main programming menu, scroll to  LOGIC and press  OK 

Scroll down to  I not on and press  OK 

Press the  + button to switch to  on and press  OK  PRG 

Use the  + and  - buttons to navigate up or down the LOGIC Sub-menu



Press the  + and  - buttons AT THE **SAME TIME** to return to the MAIN MENU 

### AUTOMATIC TORQUE ADJUSTMENT (AUTASET)



**WARNING - Gate path must be free of all traffic and obstructions. The system will automatically open and close the gate at full torque while performing the self-learning adjustment. Failure to do so can result in property damage and/or bodily injury including death.**



Gate must be fully closed and operators must have the CLOSE limit triggered before starting

From the main programming menu, scroll to  AutoSet and press  OK

Upon completion of the close cycle, the screen should display  OH. Press  OK to finalize the process.

If  Ho is displayed, check for unusual physical gate hardware resistance or incorrect installation geometry and try again.

Use the  + and  - buttons to navigate up or down the MAIN MENU



Press the  + and  - buttons AT THE **SAME TIME** to exit programming 



**SETTING THE TIMER TO CLOSE**

From the MAIN MENU, scroll to the LOGIC Sub-Menu **LOG IC** and press  OK



With **ECR** displayed on the screen, press the  OK button.



Press the  + button to turn on **ON** the timer to close and press  OK

Press the  + and  - buttons at the same time to return to the MAIN MENU **LOG IC**

Scroll up to **PARAM** (PARAMETERS) using the  + button and press  OK

With **ECR** displayed on the screen, press  OK **0 10**

Use the  + and  - buttons to increase or decrease the automatic closing time delay and press  OK

Use the  + and  - buttons to navigate up or down the PARAMETERS Sub-Menu



Press the  + and  - buttons AT THE **SAME TIME** to return to the MAIN MENU **PARAM**

**IGNORE SAFETY DEVICES DURING OPENING CYCLE**

From the MAIN MENU scroll to **LOG IC** and press  OK

Scroll down to **Photoc oPEn** and press  OK

Press the  + button to turn **ON**

Use the  + and  - buttons to navigate up or down the LOGIC Sub-menu

Press the  + and  - buttons AT THE **SAME TIME** to return to the MAIN MENU **LOG IC**

**FOR MORE OPTIONS AND FEATURES REFER TO PAGE 25**

### PROGRAMMING THE MITTO

- 1** PRESS THE RADIO LEARN BUTTON ON THE ECOSOL, ONCE TO ENABLE THE REMOTE TO OPEN AND CLOSE THE GATE **-OR-** TWICE TO ENABLE THE REMOTE TO ONLY OPEN THE GATE

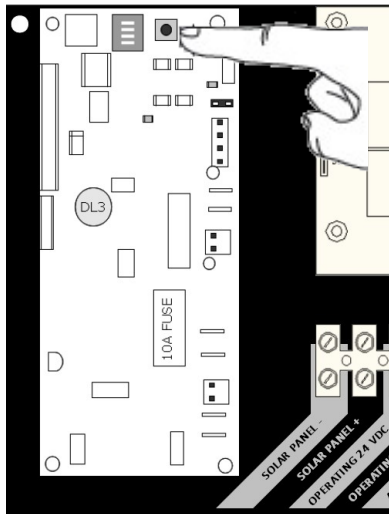

- 2** PRESS AND **HOLD** THE HIDDEN BUTTON **UNTIL** THE RED LED TURNS ON SOLID

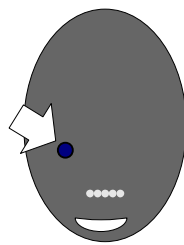

**Physical hidden button**  
BACK OF TRANSMITTER

OR

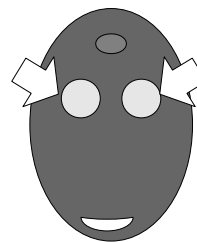

**Virtual hidden button**  
Both buttons at the same time  
FRONT OF TRANSMITTER

- 3** PRESS THE BUTTON WHICH YOU WOULD LIKE THE GATE TO OPERATE WITH. FOR ADDITIONAL MITTOS, GO TO STEP 2. WAIT 10 SECONDS AFTER LAST TRANSMITTER LEARNED TO TEST.

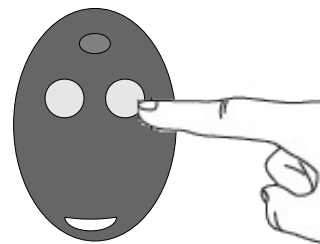

### PROGRAMMING THE T-BOX (Not included)

- 1** PRESS AND HOLD THE ON BUTTON UNTIL THE RED LED TURNS ON STEADY

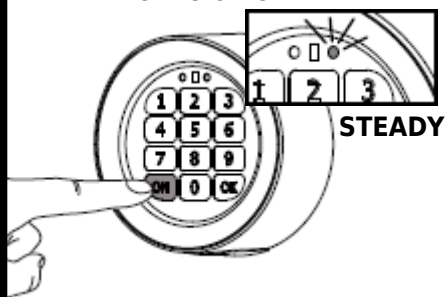

- 2** ENTER THE 4 DIGIT CODE FOR CHANNEL 1 (DEFAULT=1111)

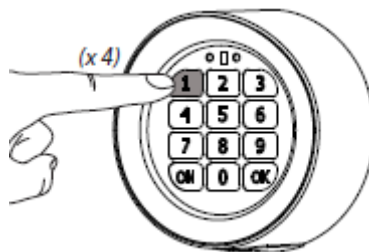

- 3** PRESS THE ON BUTTON. RED LED MUST BE BLINKING

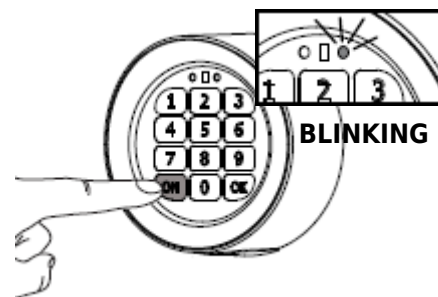

- 4** PRESS THE RADIO LEARN BUTTON ON THE ECOSOL, ONCE TO ENABLE THE KEYPAD TO OPEN AND CLOSE THE GATE **-OR-** TWICE TO ENABLE THE KEYPAD TO ONLY OPEN THE GATE

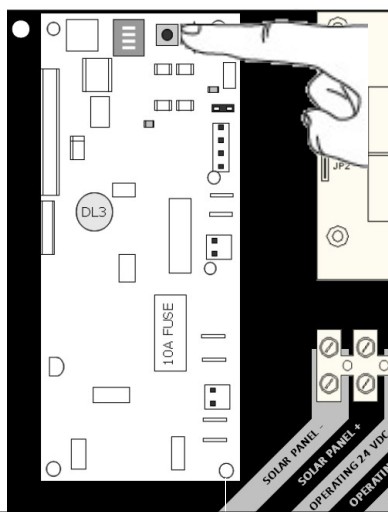

- 5** PRESS THE ON BUTTON. WAIT 10 SECONDS BEFORE TESTING THE KEYPAD. REFER TO T-BOX MANUAL FOR INSTRUCTIONS ON HOW TO CHANGE DEFAULT CODE

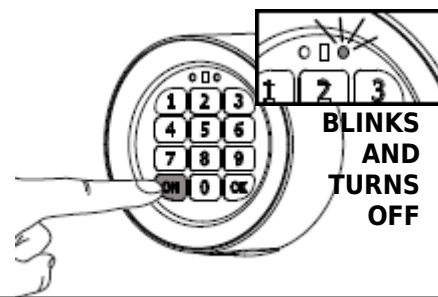

## **SOLAR PANEL**

The cells in a solar panel are dependent one on another. If one cell is shaded, it affects the output of the rest of the cells in the panel. Depending on which cell is obstructed, the total output of the panel can decrease by over 75%. It is very important to keep the surface of the solar panel clean and free of any obstruction.

Because the sun has a lower path in the sky, and the days are shorter during the winter months, our suggested panel inclination is optimized for this time of the year. Verify that the solar panel has not been moved and that its inclination and orientation is correct. Refer to page 12 for more information.

## **SURROUNDING AREA**

Inspect the surrounding area at least every winter. Objects can cast a longer shadow during the winter than during the summer. Also, trees and foliage can grow and cast shadow in areas previously clear of any shadows.

## **BATTERY**

The batteries included with your ECOSOL system are sealed maintenance free batteries. However, depending on usage and temperature conditions your batteries will require periodic replacement. Batteries may last up to 5 years under optimal conditions. Please call your qualified service technician for the replacement of them. See page 16 for more information on battery installation.

## **GATE OPERATOR**

Gate operator maintenance should be performed by a qualified service technician. Please refer to the operator's manual (Book 1) for more information.

## **GATE HARDWARE**

Disengage operator(s) using its manual release. Open and close the gate manually and look for unusual resistance. The gate should not drag on the floor at any point of the travel and it should move freely without much effort. If any anomaly is found, do not re-engage the operator and call your qualified service technician for repairs.

**System does not turn on**

- |  |  |   |  |
|--|--|---|--|
| 1. Press the test button. System should power up and after a short delay gate should start moving. | 2. Make sure that both battery leads and the jumper between the batteries are connected, and the polarity is correct. Page 16. | 3. Inspect the ECOSOL interface board main fuse for continuity. | 4. Completely disconnect the batteries and measure voltage. Each battery should at least measure 8 volts for the system to power up. |
|--|--|---|--|

**System turns on, but gate does not move.**

- |  |   |   |  |
|--|---|---|--|
| 1. Verify that dip-switch 3 is turned on at the ECOSOL interface board. Page 21. | 2. Inspect external devices such as photo-beam sensors for obstruction detection or false activation. | 3. Press the reset button and retry. If gates move after reset, inspect the gate hardware by moving the gates manually and checking for unusual resistance. | 4. Inspect motor lead connections both at the enclosure and the operator. Page 17. |
|--|---|---|--|

**Gate stops and reverses after it starts to move. AMP is displayed on board.**

- |  |  |   |
|--|--|---|
| 1. Check for physical obstructions on the gate path. | 2. Inspect the gate hardware by moving the gates manually and checking for unusual resistance. | 3. Reset torque settings by performing an AUTOSET. Page 26. |
|--|--|---|

**Gate stops during the opening cycle.**

- |  |  |   |
|--|--|---|
| 1. Make sure that the safety devices are not being triggered. To ignore external safety devices during the opening cycle, enable the PHOTOC OPEN option under the LOGIC sub-menu. Page 27. | 2. Inspect the gate hardware by moving the gates manually and checking for unusual resistance. | 3. Reset torque settings by performing an AUTOSET. Page 26. |
|--|--|---|

**After days of operation, the system stopped working.**

- |   |  |  |  |
|---|--|--|--|
| 1. Make sure that the jumper on JP14 is not closed (over both pins). Page 22.           | 2. Check wire connections between solar panel and ECOSOL. Page 14.                       | 3. Make sure that the solar panel is not shaded at anytime during the day. | 4. Verify angle and orientation of solar panel. Page 12. |
| 5. Add an additional solar panel to increase the system's recharging capacity. Page 15. | 6. Add an additional pair of batteries to increase the energy storage capacity. Page 16. |  |  |

**1 MOT ON** 1 MOT ON - See page 25

**3 STEP** 3 STEP - See page 25

**ADD START** ADD START - DOESN'T APPLY TO ECOSOL

**AMP** AMP - Indicates motor overload.

**AUTOSET** AUTOSET - See page 23

**BLOC PERSIST** BLOC PERSIST - See page 25

**CLS** CLS- CLOSE input triggered

**CLS DELAY TIME** CLS DELAY TIME - See page 24

**COD RX** COD RX - DOESN'T APPLY TO ECOSOL

**DEFAULT** DEFAULT - See page 23

**DESIRED BUTTON** DESIRED BUTTON - DOESN'T APPLY TO ECOSOL

**END** END - Indicates END OF PROGRAMMING

**ENG** ENG - ENGLISH language

**ERASE 64** ERASE 64 - DOESN'T APPLY TO ECOSOL

**ESP** ESP- SPANISH language

**FAST CLS** FAST CLS - See page 25

**FIXED CODE** FIXED CODE - See page 25

**FLT** FLT- DOESN'T APPLY TO ECOSOL

**FRA** FRA - FRENCH language

**HIDDEN BUTTON** HIDDEN BUTTON - DOESN'T APPLY TO ECOSOL

**IBL OPEN** IBL OPEN - See page 25

**ITA** ITA - ITALIAN language

**KO** KO - Indicates programming error

**LANGUAGE** LANGUAGE - See page 23

**LOGIC** LOGIC - See page 23

**M1** M1 - Refers to MOTOR 1

**M1 FAST TIME** M1 FAST TIME - See page 24

**M1 T** M1 T - See page 24

**M1 T SLOW** M1 T SLOW - See page 24

**M2** M2 - Refers to MOTOR 2

**M2 FAST TIME** M2 FAST TIME - See page 24

**M2 T** M2 T - See page 24

**M2 T SLOW** M2 T SLOW - See page 24

**MASTER** MASTER - See page 25

**OK** OK - Indicates programming accepted

**OPEN** OPEN - OPEN input triggered

**OPEN DELAY TIME** OPEN DELAY TIME - See page 24

**PARAM** PARAM - See page 23

**PHOT** PHOT - SAFETY input triggered

**PHOTOC OPEN** PHOTOC OPEN - See page 25

**RADIO** RADIO - See page 23

**RADIO PROG** RADIO PROG - See page 25

**RELEASE** RELEASE - DOES NOT APPLY TO ECOSOL

**SLOW SPEED** SLOW SPEED - See page 24

**START-CLOSE** START-CLOSE - See page 25

**STOP** STOP - STOP input triggered

**STRT** STRT - START input triggered

**TCA** TCA - Refers to TIMER TO CLOSE. See pages 24 & 25.

**TEST PHOT** TEST PHOT - See page 25

**ZONE** ZONE - See page 24



**BFT USA**

6100 Broken Sound Pkwy N.W.  
Suite 14  
Boca Raton FL 33487, U.S.A.  
Toll Free (U.S. Only): 877-995-8155  
Main Office: 561-995-8155  
Fax: 561-995-8160  
Email: info.bft@bft-usa.com

**WELCOME TO WORLD OF TRUST**

BFT is a world leading manufacturer of innovative and highly reliable electromechanical and hydraulic gate automation systems. We pride ourselves in providing outstanding customer service.

BFT is a global company in business since 1980 with subsidiaries in 15 countries worldwide. It is owned since 2004 by Somfy, the world leader in automation for window shades and shutters.

BFT US Inc, with its offices in Boca Raton, Florida offers, sales, logistics, technical support and customer service throughout USA, Canada and the Caribbean Islands

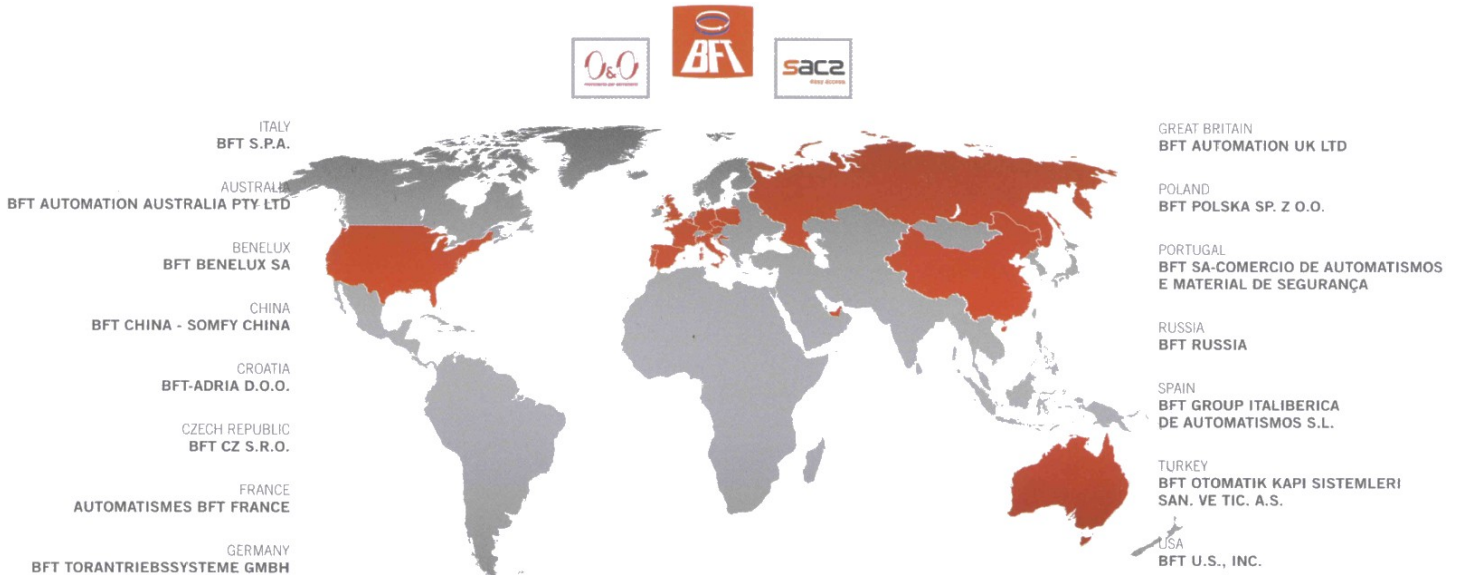

ITALY  
BFT S.P.A.

AUSTRALIA  
BFT AUTOMATION AUSTRALIA PTY LTD

BENELUX  
BFT BENELUX SA

CHINA  
BFT CHINA - SOMFY CHINA

CROATIA  
BFT-ADRIA D.O.O.

CZECH REPUBLIC  
BFT CZ S.R.O.

FRANCE  
AUTOMATISMES BFT FRANCE

GERMANY  
BFT TORANTRIEBSSYSTEME GMBH

GREAT BRITAIN  
BFT AUTOMATION UK LTD

POLAND  
BFT POLSKA SP. Z O.O.

PORTUGAL  
BFT SA-COMERCIO DE AUTOMATISMOS  
E MATERIAL DE SEGURANCA

RUSSIA  
BFT RUSSIA

SPAIN  
BFT GROUP ITALIBERICA  
DE AUTOMATISMOS S.L.

TURKEY  
BFT OTOMATIK KAPI SISTEMLERI  
SAN. VE TIC. A.S.

USA  
BFT U.S., INC.

INSTALLED BY: \_\_\_\_\_

PHONE: \_\_\_\_\_

INSTALLATION DATE: \_\_\_\_\_

INVOICE NUMBER: \_\_\_\_\_

**TECH SUPPORT U.S. TOLL FREE: 877-995-8155 / INT'L: +1-561-995-8155**