

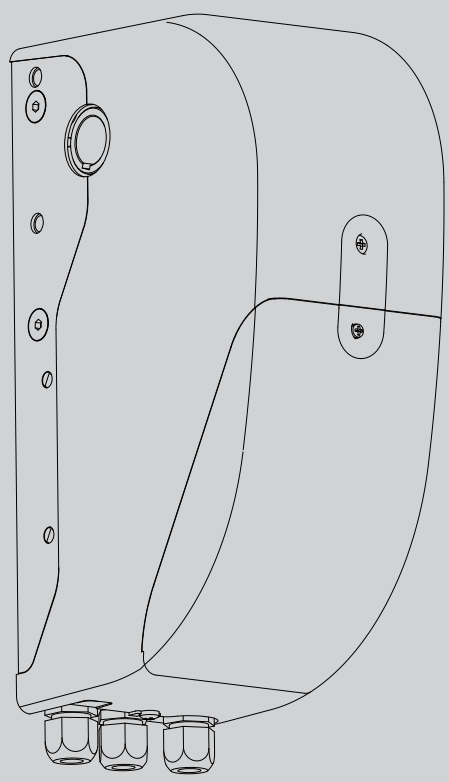

D81162700100_04 28-01-11

AUTOMAZIONI PER PORTE SEZIONALI INDUSTRIALI
OPERATORS FOR INDUSTRIAL SECTIONAL DOORS
AUTOMATISMES POUR PORTES MULTI-LAMES INDUSTRIELLES
AUTOMATISCHE ANTRIEBE FÜR INDUSTRIE-SEKTIONALTORE
AUTOMATISMOS PARA PUERTAS SECCIONALES INDUSTRIALES
AUTOMATISERINGEN VOOR INDUSTRIËLE OPDRACHTGERICHTE DEUREN



ARGO ARGO G

ISTRUZIONI DI INSTALLAZIONE
INSTALLATION MANUAL
INSTRUCTIONS D'INSTALLATION
MONTAGEANLEITUNG
INSTRUCCIONES DE INSTALACION
INSTALLATIEVOORSCHRIFTEN

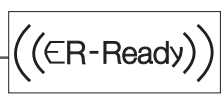
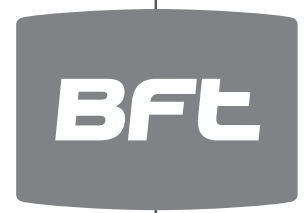

AZIENDA CON SISTEMA DI GESTIONE
INTEGRATO CERTIFICATO DA DNV
= UNI EN ISO 9001:2008 =
UNI EN ISO 14001:2004

Attenzione! Leggere attentamente le "Avvertenze" all'interno! **Caution!** Read "Warnings" inside carefully! **Attention!** Veuillez lire attentivement les Avertissements qui se trouvent à l'intérieur! **Achtung!** Bitte lesen Sie aufmerksam die „Hinweise“ im Inneren! **¡Atención!** Leer atentamente las "Advertencias" en el interior! **Let op!** Lees de "Waarschuwingen" aan de binnenkant zorgvuldig!

INSTALLAZIONE VELOCE-QUICK INSTALLATION-INSTALLATION RAPIDE SCHNELLINSTALLATION-INSTALACIÓN RÁPIDA - SNELLE INSTALLATIE

D811627 00100_04

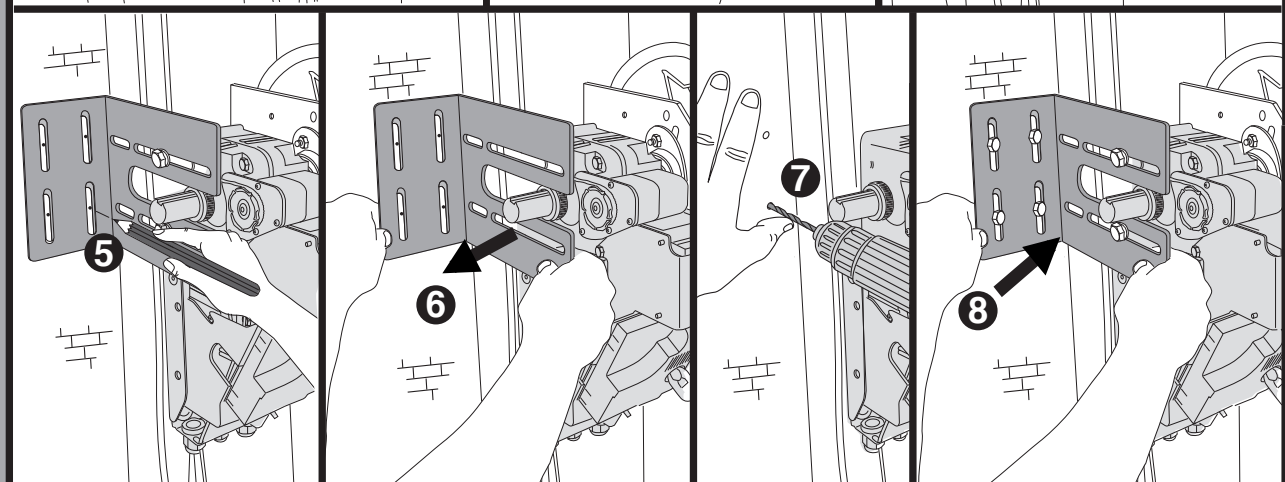
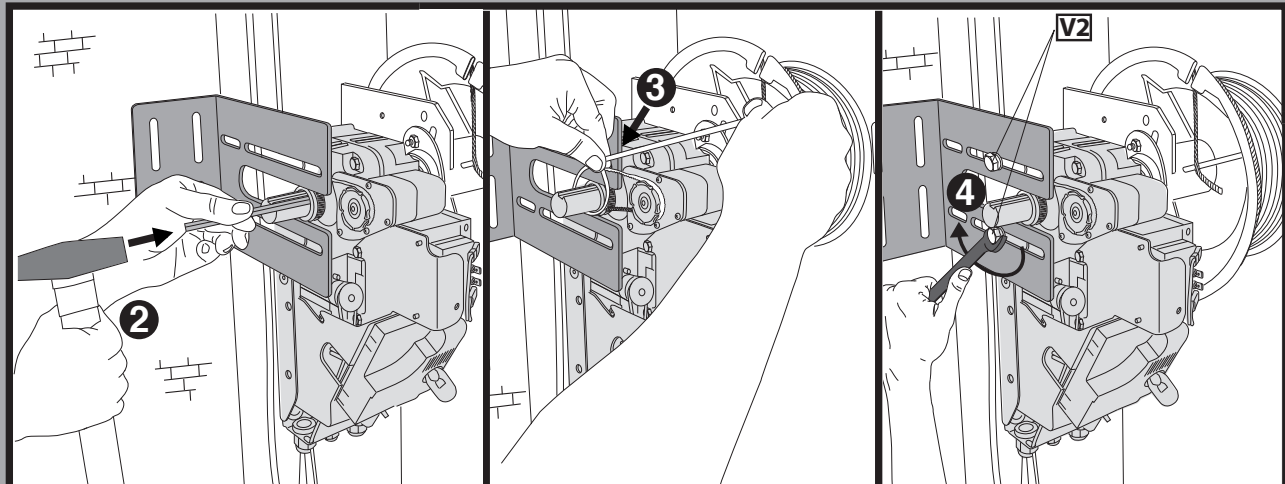
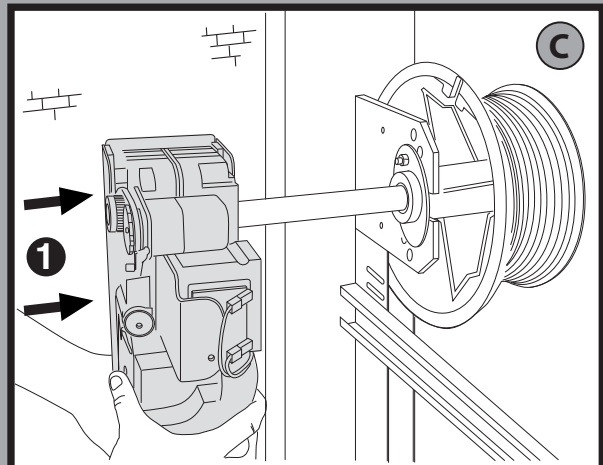
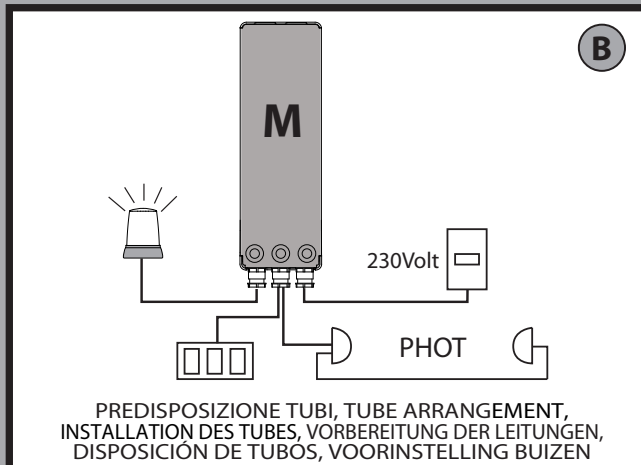
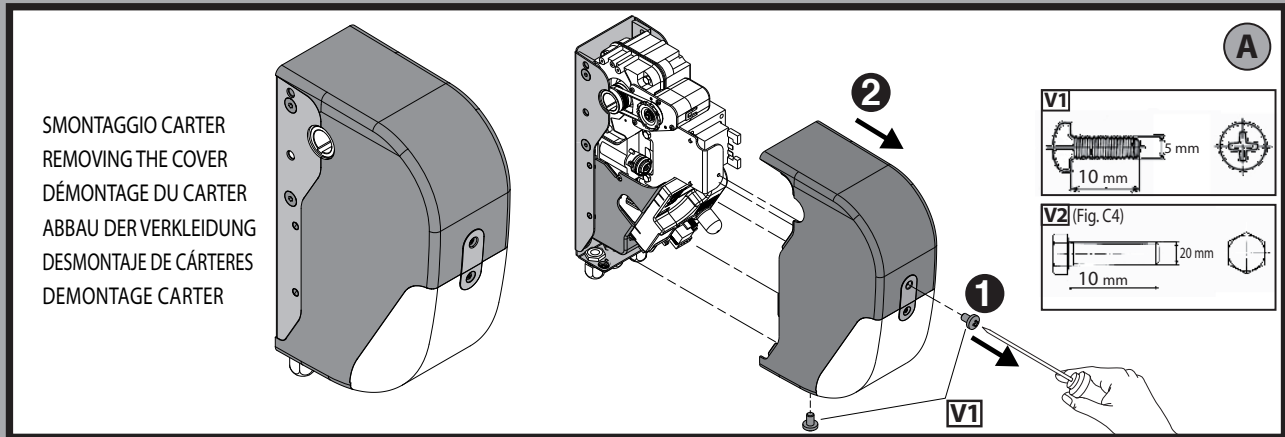

F

AUTOSET COPPIA APERTURA-CHIUSURA
OPENING-CLOSING TORQUE AUTOSETTING
RÉGLAGE AUTOMATIQUE COUPLE OUVERTURE-FERMETURE
AUTOSET DREHMOMENT ÖFFNUNG-SCHLIESSUNG
AJUSTE AUTOMÁTICO DEL PAR EN FASE DE APERTURA-CIERRE
AUTOSET DRAAIMOMENT OPENING - SLUITING.

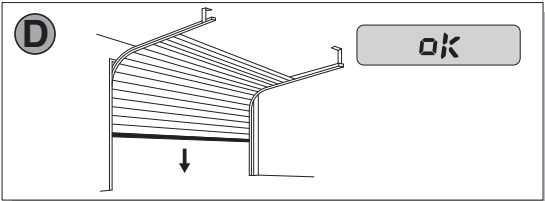
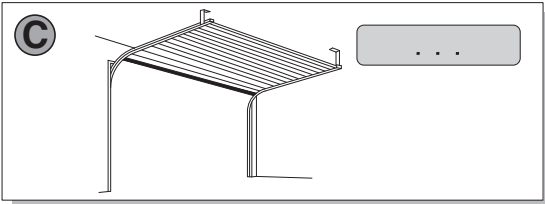
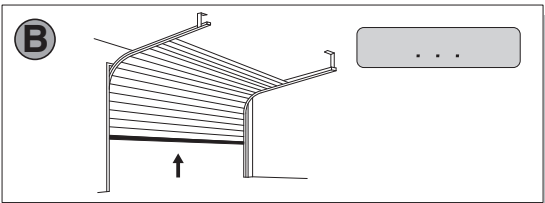
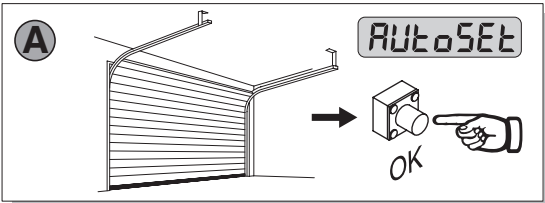
**G**

MEMORIZZAZIONE RADIOCOMANDO
MEMORIZING REMOTE CONTROLS
MÉMORISATION DE LA RADIOCOMMANDE
ABSPEICHERUNG DER FERNBEDIENUNG
MEMORIZACIÓN DEL RADIOMANDO
MEMORISEREN AFSTANDSBEDIENING

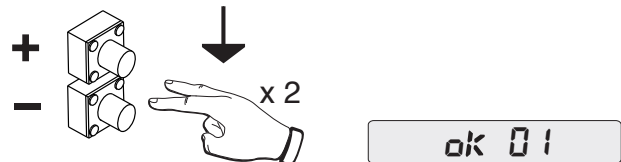
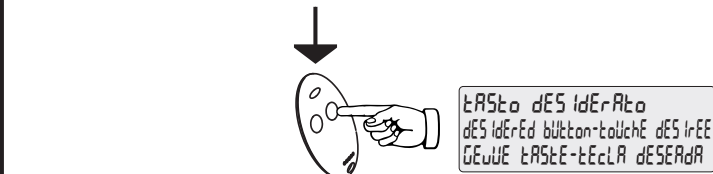
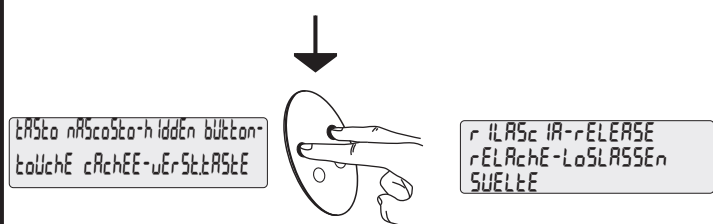
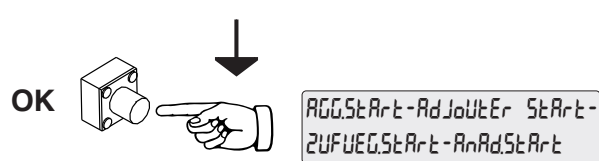
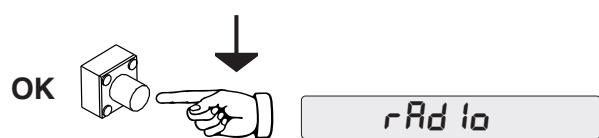
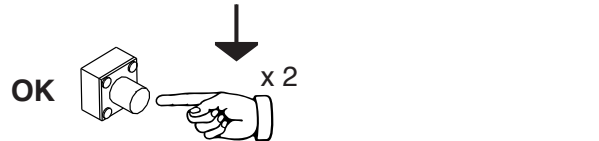
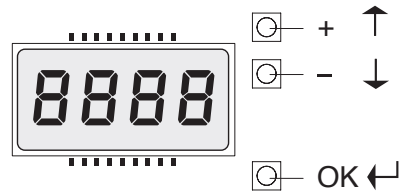
**End**

D811627 00100_04

H

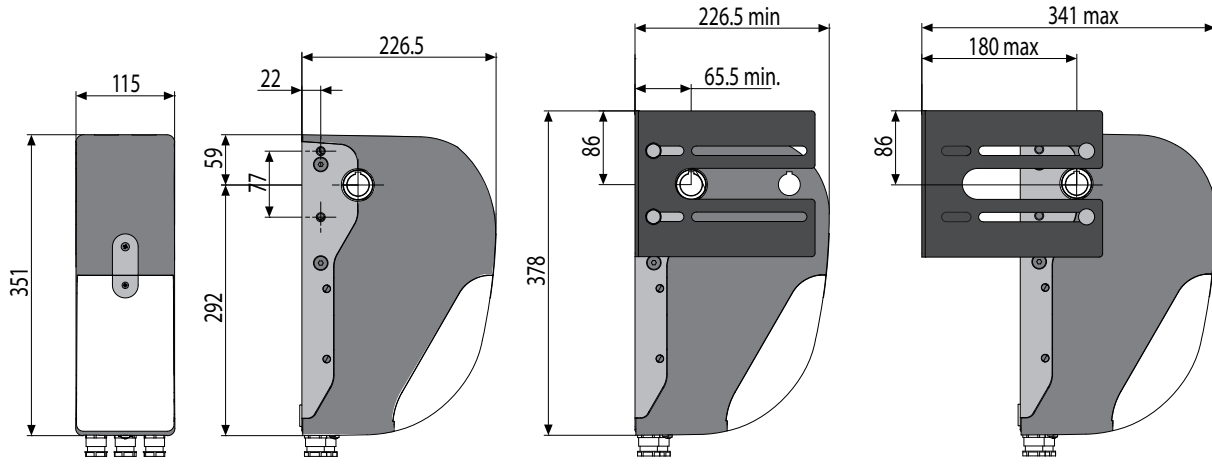

I

Ingresso cavi dall'alto,
Cable entry from above,
Entrée câbles du haut,
Kabeleingang von oben,
Entraa cables desde arriba,
Ingang kabels van de hoogte

Ingresso cavi dalla parete,
Cable entry from wall,
Entrée câbles du réseau,
Kabeleingang von Wand,
Entraa cables desde la pared,
Ingang kabels van de wand

Ingresso cavi dal basso,
Cable entry from below,
Entrée câbles du bas,
Kabeleingang von unten,
Entraa cables desde abajo,
Ingang kabels van beneden

APERTURA (InuPate=OFF)
TO OPEN (chAnUE Pate=OFF)
OUVERTURE (InuPate=OFF)
ÖFFNUNG (Pate:RU5ch=OFF)
APERTURA (InuPate=OFF)
OPENING (chAnUE Pate=OFF)

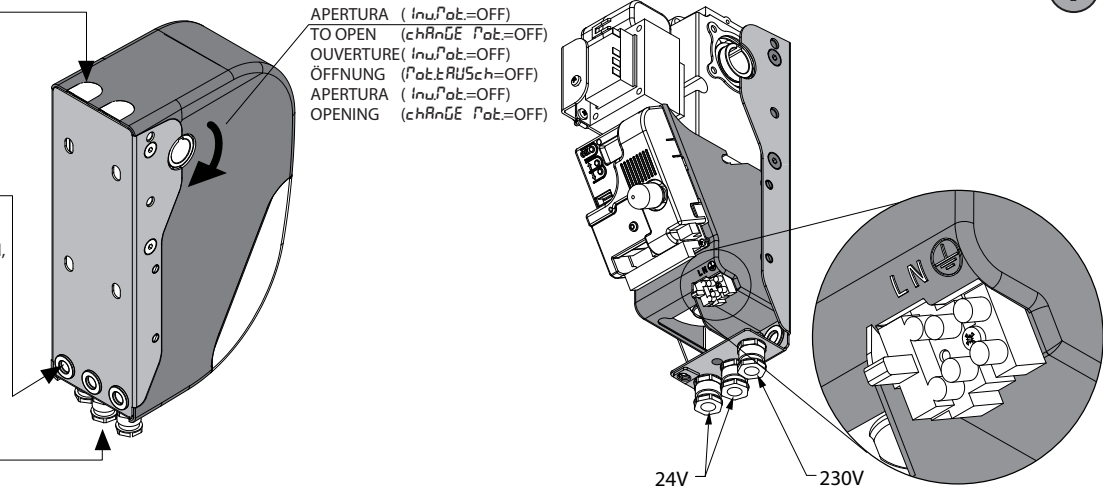

J

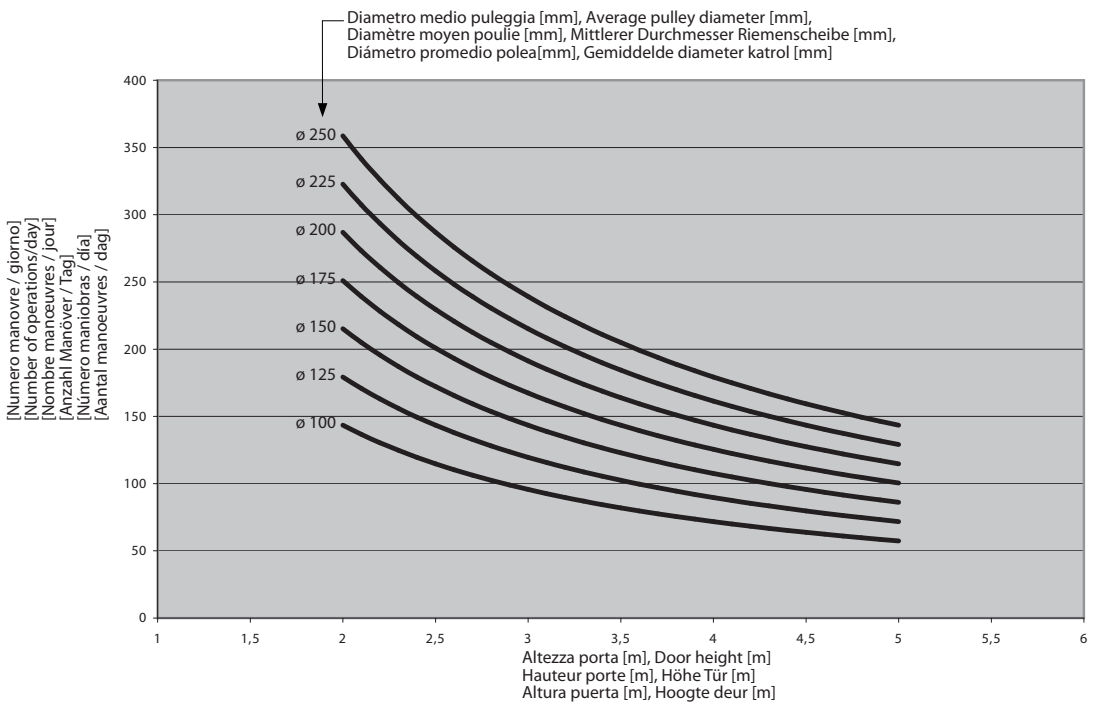

PROGRAMMAZIONE TRASMETTITORI REMOTA, REMOTE TRANSMITTER PROGRAMMING, PROGRAMMATION ÉMETTEURS A DISTANCE, FERNPROGRAMMIERUNG DER SENDER, PROGRAMACION DE TRANSMISORES REMOTA, REMOTE PROGRAMMING TRANSMITTERS

K

1 Radiocomando già memorizzato
Radio transmitter already memorised
Radiocommande déjà mémorisée
Bereits gespeicherte Funksteuerung
Radiomando ya memorizado
Reeds gememoriseerde afstandsbediening



2 Radiocomando già memorizzato
Radio transmitter already memorised
Radiocommande déjà mémorisée
Bereits gespeicherte Funksteuerung
Radiomando ya memorizado
Reeds gememoriseerde afstandsbediening



3 Radiocomando da memorizzare
Radio transmitter to memorise
Radiocommande à mémoriser
Zu speichernde Funksteuerung
Radiomando que memorizar
Te memoriseren afstandsbediening



4 Radiocomando da memorizzare
Radio transmitter to memorise
Radiocommande à mémoriser
Zu speichernde Funksteuerung
Radiomando que memorizar
Te memoriseren afstandsbediening



FOTOCELLULE
FOTOZELLEN

PHOTOCELLS
FOTOCÉLULAS

PHOTOCELLULES
FOTOCELLEN

COSTE
LEISTEN

SAFETY EDGES
CANTOS

LINTEAUX
RANDEN

L

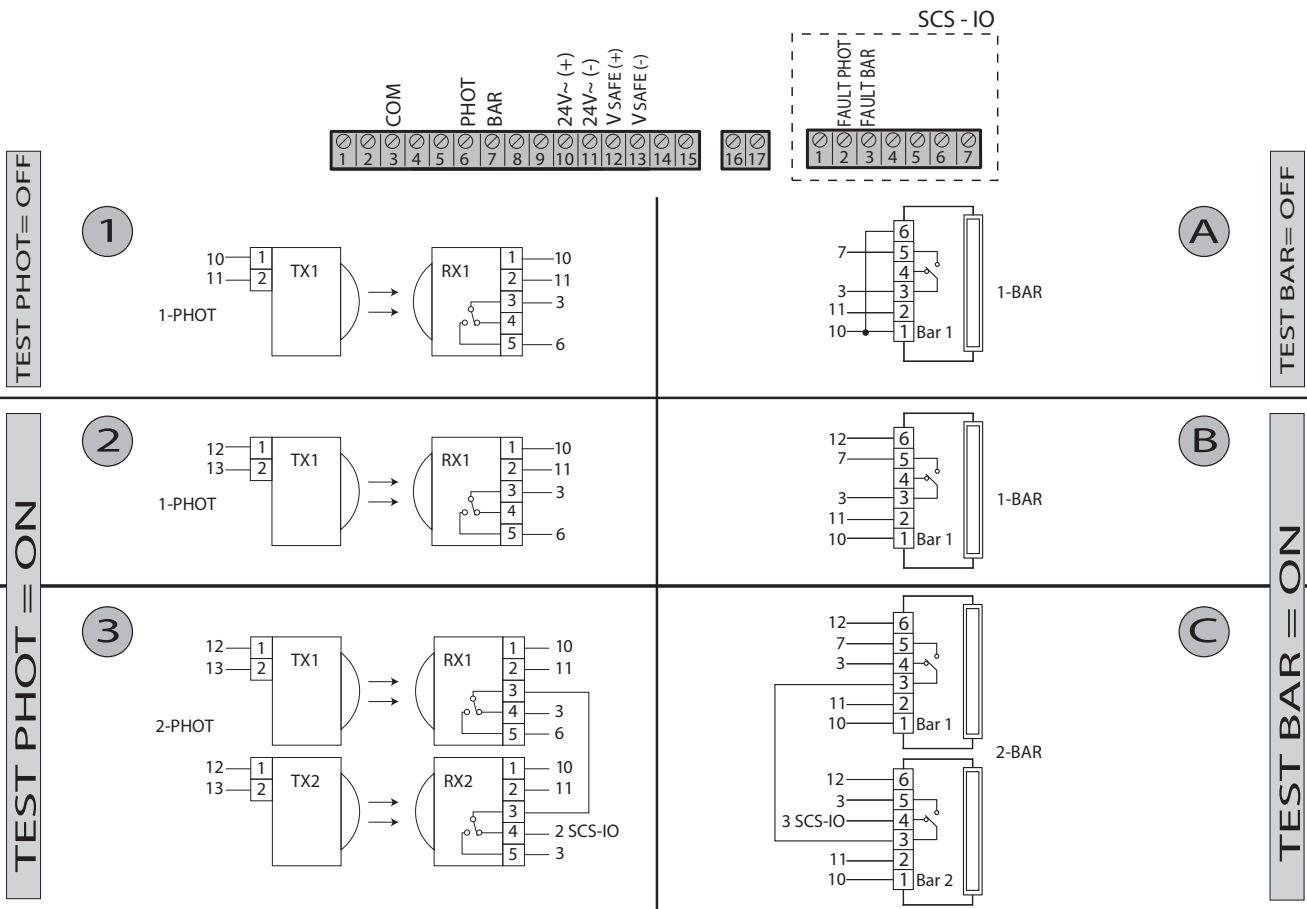

Combinazioni possibili, Possible combinations, Combinaisons possibles, Mögliche Kombinationen, Combinaciones posibles, Mogelijke combinaties

COSTE LEISTEN SAFETY EDGES	CANTOS LINTEAUX RANDEN	A	B	C	A	B	C	A	B	C
FOTOCELLULE FOTOZELLEN PHOTOCELLS	FOTOCÉLULAS PHOTOCELLULES FOTOCELLEN	1	1	1	2	2	2	3	3	3

M

Connessione Seriale Mediante Scheda Scs1, Serial Connection Via Scs1 Card, Connexion Série À Travers La Carte Scs1, Serielle Verbindung Mit Karte Scs1, Conexión Serial Mediante Tarjeta Scs1, Serielle Verbindung Middels Kaart Scs1

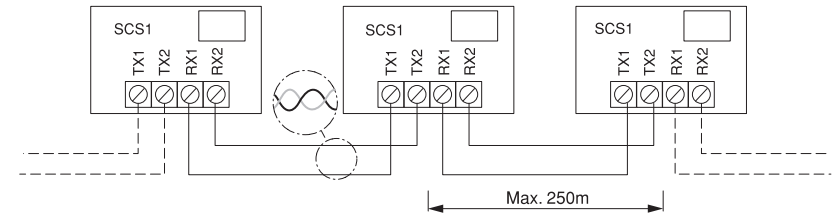

ACCESS TO MENU

D0811627/001.00_04

Press the OK key

bFt Control unit software version
RbcdEF N. total manoeuvres (in tens)
0000 N. manoeuvres since latest maintenance (in tens)
0000 N. radio control devices memorised
00

LEGENDA

+

-

OK

Scroll up } Cancel/return to main menu

Scroll down }

Confirm/Switch on display

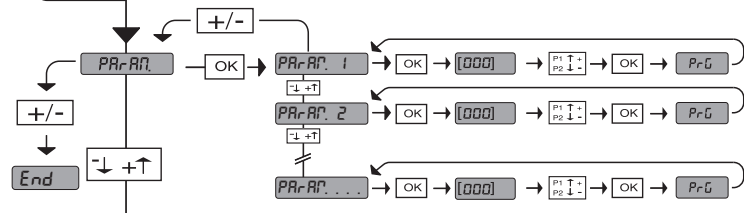

See PARAMETERS MENU

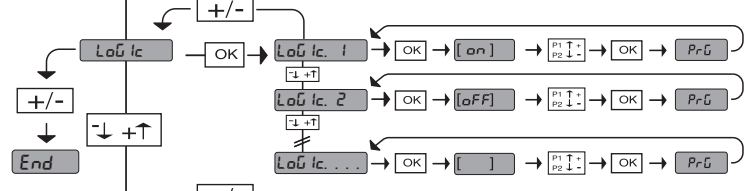

See LOGIC MENU

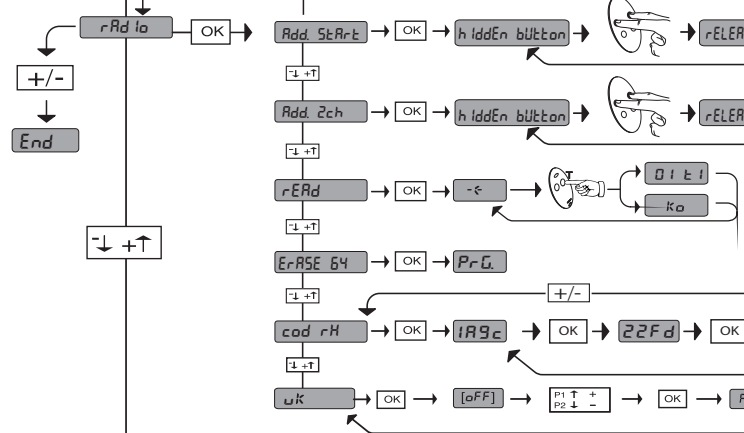

See RADIO MENU

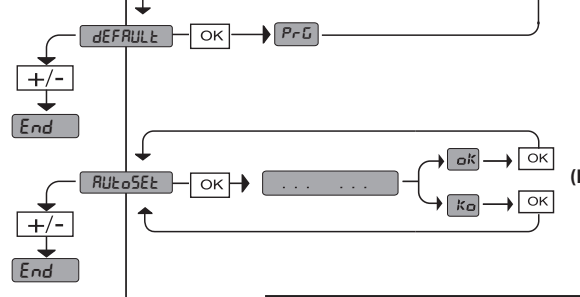
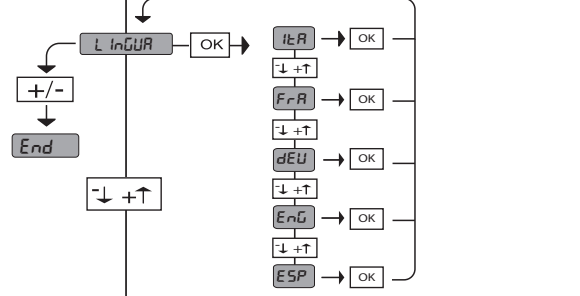

(Fig. F)

Logic	Description
PEd	partial opening input activated
StErE	START input activated
StoP	STOP input activated
PhoE	PHOT input activated
bRr	SAFETY EDGE input activated
cLoS	CLOSE input activated
oPEn	OPEN input activated
SUo	opening limit switch activated
SUc	closing limit switch activated
RrP	reverse due to obstacle
SEt	autoset function is running WARNING! Obstacle detection function is not active
Er 01	photocell test error
Er 02	safety edge test error
Er 10	mosfet test error
Er 11	shunt test error
Er 21	encoder test error
Er 40	thermal cutout error
Er 50	optional module communication error

35.40	<ul style="list-style-type: none"> └── Set torque threshold % └── Maximum motor torque %
--------------	--

WARNING! Important safety instructions. Carefully read and comply with all the warnings and instructions that come with the product as incorrect installation can cause injury to people and animals and damage to property. The warnings and instructions give important information regarding safety, installation, use and maintenance. Keep hold of instructions so that you can attach them to the technical file and keep them handy for future reference.

GENERAL SAFETY

This product has been designed and built solely for the purpose indicated herein. Uses other than those indicated herein might cause damage to the product and create a hazard.

- The units making up the machine and its installation must meet the requirements of the following European Directives, where applicable: 2004/108/EC, 2006/95/EC, 2006/42/EC, 89/106/EC, 99/05/EC and later amendments. For all countries outside the EEC, it is advisable to comply with the standards mentioned, in addition to any national standards in force, to achieve a good level of safety.
- The Manufacturer of this product (hereinafter referred to as the "Firm") disclaims all responsibility resulting from improper use or any use other than that for which the product has been designed, as indicated herein, as well as for failure to apply Good Practice in the construction of entry systems (doors, gates, etc.) and for deformation that could occur during use.
- Installation must be carried out by qualified personnel (professional installer, according to EN 12635), in compliance with Good Practice and current code.
- Before commencing installation, check the product for damage.
- Before installing the product, make all structural changes required to produce safety gaps and to provide protection from or isolate all crushing, shearing and dragging hazard areas and danger zones in general. Check that the existing structure meets the necessary strength and stability requirements.
- The Firm is not responsible for failure to apply Good Practice in the construction and maintenance of the doors, gates, etc. to be motorized, or for deformation that might occur during use.
- Make sure the stated temperature range is compatible with the site in which the automated system is due to be installed.
- Do not install this product in an explosive atmosphere: the presence of flammable fumes or gas constitutes a serious safety hazard.
- Disconnect the electricity supply before performing any work on the system. Also disconnect buffer batteries, if any are connected.
- Before connecting the power supply, make sure the product's ratings match the mains ratings and that a suitable residual current circuit breaker and overcurrent protection device have been installed upline from the electrical system. Have the automated system's mains power supply fitted with a switch or omnipolar thermal-magnetic circuit breaker with a contact separation of at least 3.0mm and any other equipment required by code.
- Make sure that upline from the mains power supply there is a residual current circuit breaker that trips at no more than 0.03A as well as any other equipment required by code.
- Make sure the earth system has been installed correctly: earth all the metal parts belonging to the entry system (doors, gates, etc.) and all parts of the system featuring an earth terminal.
- Installation must be carried out using safety devices and controls that meet standards EN 12978 and EN 12453.
- Impact forces can be reduced by using deformable edges.
- In the event impact forces exceed the values laid down by the relevant standards, apply electro-sensitive or pressure-sensitive devices.
- Apply all safety devices (photocells, safety edges, etc.) required to keep the area free of impact, crushing, dragging and shearing hazards. Bear in mind the standards and directives in force, Good Practice criteria, intended use, the installation environment, the operating logic of the system and forces generated by the automated system.
- Apply all signs required by current code to identify hazardous areas (residual risks). All installations must be visibly identified in compliance with the provisions of standard EN 13241-1.
- This product cannot be installed on leaves incorporating doors (unless the motor can be activated only when the door is closed).
- If the automated system is installed at a height of less than 2.5 m or is accessible, the electrical and mechanical parts must be suitably protected.
- Install any fixed controls in a position where they will not cause a hazard, away from moving parts. More specifically, hold-to-run controls must be positioned within direct sight of the part being controlled and, unless they are key operated, must be installed at a height of at least 1.5 m and in a place where they cannot be reached by the public.
- Apply at least one warning light (flashing light) in a visible position, and also attach a Warning sign to the structure.
- Attach a label near the operating device, in a permanent fashion, with information on how to operate the automated system's manual release.
- Make sure that, during operation, mechanical risks are avoided or relevant protective measures taken and, more specifically, that nothing can be banged, crushed, caught or cut between the part being operated and surrounding parts.
- Once installation is complete, make sure the motor automation settings are correct and that the safety and release systems are working properly.
- Only use original spare parts for any maintenance or repair work. The Firm disclaims all responsibility for the correct operation and safety of the automated system if parts from other manufacturers are used.
- Do not make any modifications to the automated system's components unless explicitly authorized by the Firm.
- Instruct the system's user on what residual risks may be encountered, on the control systems that have been applied and on how to open the system manually in an emergency, give the user guide to the end user.
- Dispose of packaging materials (plastic, cardboard, polystyrene, etc.) in accordance with the provisions of the laws in force. Keep nylon bags and polystyrene out of reach of children.

WIRING

WARNING! For connection to the mains power supply, use a multicore cable with a cross-sectional area of at least 4x1.5mm² of the kind provided for by the regulations mentioned above (by way of example, type H05 VV-F cable can be used with a cross-sectional area of 4x1.5mm²). To connect auxiliary equipment, use wires with a cross-sectional area of at least 0.5 mm².

- Only use pushbuttons with a capacity of 10A-250V or more.
- Wires must be secured with additional fastening near the terminals (for example, using cable clamps) in order to keep live parts well separated from safety extra low voltage parts.
- During installation, the power cable must be stripped to allow the earth wire to be connected to the relevant terminal, while leaving the live wires as short as possible. The earth wire must be the last to be pulled taut in the event the cable's fastening device comes loose.

WARNING! safety extra low voltage wires must be kept physically separate from low voltage wires.

Only qualified personnel (professional installer) should be allowed to access live parts.

CHECKING THE AUTOMATED SYSTEM AND MAINTENANCE

Before the automated system is finally put into operation, and during maintenance work, perform the following checks meticulously:

- Make sure all components are fastened securely.
- Check starting and stopping operations in the case of manual control.
- Check the logic for normal or personalized operation.
- For sliding gates only: check that the rack and pinion mesh correctly with 2 mm of play; keep the track the gate slides on clean and free of debris at all times.
- Check that all safety devices (photocells, safety edges, etc.) are working properly and that the anti-crush safety device is set correctly, making sure that the force of impact measured at the points provided for by standard EN 12445 is lower than the value laid down by standard EN 12453.
- Make sure that the emergency operation works, where this feature is provided.
- Check opening and closing operations with the control devices applied.
- Check that electrical connections and cabling are intact, making extra sure that insulating sheaths and cable glands are undamaged.
- While performing maintenance, clean the photocells' optics.
- When the automated system is out of service for any length of time, activate the emergency release (see "EMERGENCY OPERATION" section) so that the operated part is made idle, thus allowing the gate to be opened and closed manually.

SCRAPPING

Materials must be disposed of in accordance with the regulations in force. There are no particular hazards or risks involved in scrapping the automated system. For the purpose of recycling, it is best to separate dismantled parts into like materials (electrical parts - copper - aluminium - plastic - etc.).

DISMANTLING

If the automated system is being dismantled in order to be reassembled at another site, you are required to:

- Cut off the power and disconnect the whole electrical system.
- Remove the actuator from the base it is mounted on.
- Remove all the installation's components.
- See to the replacement of any components that cannot be removed or happen to be damaged.

Anything that is not explicitly provided for in the installation manual is not allowed. The operator's proper operation can only be guaranteed if the information given is complied with. The Firm shall not be answerable for damage caused by failure to comply with the instructions featured herein.

While we will not alter the product's essential features, the Firm reserves the right, at any time, to make those changes deemed opportune to improve the product from a technical, design or commercial point of view, and will not be required to update this publication accordingly.

2) GENERAL INFORMATION

Actuator for motorizing residential and industrial sectional doors. Its compact design and mounting versatility mean the drive can be applied in different ways.

3) TECHNICAL SPECIFICATIONS	
Power supply:	230V ±10%, 50/60Hz (*)
Max. power input:	240W
Limit switch:	Electronic ENCODER model Output shaft MAX. 18 rpm
Courtesy light (ARGO):	24V bulb ~ max. 25W, E14
Operating temperature range:	-15°C / +55°C
Max. door size:	ARGO: 20 m ² ARGO G: 35 m ²
Max. torque:	ARGO: 55 Nm ARGO G: 80 Nm
Max output rpm:	ARGO: 30 min ⁻¹ ARGO G: 18 min ⁻¹
Lubrication:	Lifetime greased
Manual operation:	Knob-operated mechanical release
Protection rating:	IP 40
Noise level:	<70dBA
Operator weight:	10 kg
Dimensions:	See Fig. H
Accessories power supply:	24V~ (180 mA)
Flashing light connection:	24V max 25W
Fuses:	See Fig. D
Built-in Rolling-Code radio-receiver:	frequency 433.92MHz

(*) Special supply voltages to order.

Usable transmitter versions:
All ROLLING CODE transmitters compatible with
4) REMOVING THE COVER Fig. A



5) TUBE ARRANGEMENT Fig. B

6) INSTALLING THE OPERATOR Fig. C

7) CABLE ENTRY FIG. I

8) MANUAL RELEASE (See USER GUIDE -FIG. 1-).

9) WIRING

TERMINAL	DESCRIPTION
JP2	Transformer wiring
JP10	Motor wiring
1-2	Antenna input for built-in radio-receiver board (1: BRAIDING 2: SIGNAL)
3-4	START/OPEN INPUT (N.O.)
3-5	STOP input (N.C.) If not used, leave jumper inserted
3-6	PHOTOCELL input (N.C.) If not used, leave jumper inserted
3-7	SAFETY EDGE input (N.C.) If not used, leave jumper inserted
8-9	24 V~ output for flashing light (max. 25 W)
10-11	24V~ max. 180mA output - power supply to photocells or other devices.
12-13	24V~ Vsafe max. 180mA output - power supply to transmitters photocells with test.
14-15	(NO contact) / Output 1 height programmable
16-17	PARTIAL OPENING/CLOSE input (N.O.)
1-2 (SCS-IO)	PHOT-FAULT input (NO). Input for photocells equipped with NO test contact.
1-3 (SCS-IO)	BAR-FAULT input (NO). Input for safety edges equipped with NO test contact.
4-5 (SCS-IO)	(NO contact) / Output 2 Height programmable
6-7 (SCS-IO)	Gate open light/2nd radio channel output (NO contact)

14 - ARGO-ARGO G

9.1) SAFETY DEVICES

When using the SCS-IO board with the photocell test feature, the Fault must be connected.

Note: only use receiving safety devices with free changeover contact.

- 1-A: Connection of 1 untested device (photocell or safety edge).
- Fig. L2-B: Connection of 1 tested device (photocell or safety edge).
- Fig. L3-C: Connection of 2 tested devices (photocells or safety edges). This connection is made possible via the SCS-IO optional module only.

10) ADJUSTMENTS

RECOMMENDED ADJUSTMENT SEQUENCE:

Adjusting the limit switches (Fig. E)
Autoset (Fig. F)
Programming remote controls (Fig. G)
Setting of parameters/logic, where necessary

**10.1) PARAMETERS MENU (PR-RN)
 (TABLE "A" PARAMETERS)**

**10.2) LOGIC MENU (LoGIC)
 (TABLE "B" LOGIC)**

10.3) RADIO MENU (rRadia)

Logic	Description
<i>Rdd StArt</i>	Add Start Key associates the desired key with the Start command
<i>Rdd 2ch</i>	Add 2ch Key associates the desired key with the 2nd radio channel command
<i>rERd</i>	Read Checks a key of a receiver and, if memorized, returns the number of the receiver in the memory location (from 01 to 64) and number of the key (T1-T2-T3 or T4).
<i>ErASE 64</i>	Erase List WARNING! Erases all memorized remote controls from the receiver's memory.
<i>cod rH</i>	Read receiver code Displays receiver code required for cloning remote controls.
<i>W</i>	ON = Enables remote programming of cards via a previously memorized W LINK transmitter. It remains enabled for 3 minutes from the time the W LINK remote control is last pressed. OFF =W LINK programming disabled.

- IMPORTANT NOTE: THE FIRST TRANSMITTER MEMORIZED MUST BE IDENTIFIED BY ATTACHING THE KEY LABEL (MASTER).

In the event of manual programming, the first transmitter assigns the RECEIVER'S KEY CODE: this code is required to subsequently clone the radio transmitters. The Clonix built-in on-board receiver also has a number of important advanced features:

- Cloning of master transmitter (rolling code or fixed code)
- Cloning to replace transmitters already entered in receiver
- Transmitter database management
- Receiver community management

To use these advanced features, refer to the universal handheld programmer's instructions and to the CLONIX Programming Guide, which come with the universal handheld programmer device.

10.4) LANGUAGE MENU (LANGUAGGE)

Used to set the programmer's language on the display.

10.5) DEFAULT MENU (dEFault)

Restores the controller's default factory settings.

10.6) AUTOSSET MENU (AutosEt) (Fig. F)

- Move the door to the closed position.
- Launch an autoset operation by going to the relevant menu on the VENERE D panel.
- As soon as you press the OK button, the "... .." message is displayed and the control unit commands the door to perform a full cycle (opening followed by closing), during which the minimum torque value required for the door to move is set automatically.

During this stage, it is important to avoid breaking the photocells' beams and not to use the START and STOP commands or the display.

Once this operation is complete, the control unit will have automatically set the optimum torque values. Check them and, where necessary, edit them as described in the programming section.

WARNING: Check that the force of impact measured at the points provided for by standard EN 12445 is lower than the value laid down by standard EN 12453.

Warning!! While the autose t function is running, the obstacle detection function is not active. Consequently, the installer must monitor the automated system's movements and keep people and property out of range of the automated system.

10.7) LIMIT SWITCH ADJUSTMENT MENU (L.Sw Adj) (Fig. E)

Limit switch adjustment procedure:

- 1) Go to L.SW ADJ and confirm with OK.
- 2) The display reads CLOSE. Use the UP and DOWN keys to move the door to the closing limit switch position. Confirm with OK. The display reads PRG.
- 3) If prompted by the display, turn the adjustment ring: anticlockwise if the display reads UP; clockwise if the display reads DOWN. Once you have reached the correct position, the display reads OK. Confirm with the OK key. The display reads PRG.
- 4) The display reads OPEN. Use the UP and DOWN keys to move the door to the opening limit switch position. Confirm with OK. The display reads PRG.

If the display reads KO, it means adjustment was not successful.

This may be caused by:

- the ESC key being pressed before adjustment was completed
- stored travel being too short

11) SCS OPTIONAL MODULES

11.1) SERIAL CONNECTION VIA SCS1 CARD (Fig. O)

The VENERE D control panel's special serial inputs and outputs (SCS1) make the centralized connection of a number of automated devices possible. That way, all the automated devices connected can be opened or closed with a single command.

Connect all VENERE D control panels using twisted pair cabling only, proceeding as shown in the diagram in Fig. O.

When using a telephone cable with more than one pair, it is essential to use wires from the same pair.

The length of the telephone cable between one unit and the next must not be greater than 250 m.

At this point, each VENERE D control panel needs to be configured appropriately, starting by entering a MASTER control panel that will have control over all the others, which therefore have to be set as SLAVE units (see logic menu).

Also set the Zone number (see parameters menu) in the range 0 to 127.

The zone number allows you to create groups of automated devices, each of which answers to the Zone Master. Each zone can have only one Master: the Master of zone 0 also controls the Slaves of the other zones.

11.2) Interface with WIEGAND systems via SCS-WIE module.

Refer to the SCS-WIE module's instructions.

11.3) Expanding inputs and outputs via the SCS-IO optional module.

The SCS-IO optional module can be used to add 2 inputs and 2 outputs to the VENERE-D board (Fig. D).

To activate the connection between SCS-IO and VENERE-D, you need to plug the SCS-IO module into the relevant connector and then set the ZONE parameter to 129.

At this point, the 2 boards are synchronized and the SCS-IO board's inputs/outputs are managed by the VENERE-D board.

TABLE "A" - PARAMETERS MENU - (PARAM)

Logic	min.	max.	default	Definition	Description
tcR	0	120	40	Automatic Closing Time	Automatic closing time [s]
oP. t	1	99	75	Opening motor torque	Opening torque [%] Sets sensitivity to obstacles during opening (1=max., 99=min.) The autose t feature sets this parameter automatically to a value of 10%. The user can edit this parameter based on how sensitive the door needs to be to obstacles.
cL.S. t	1	99	75	Closing motor torque	Closing torque [%] Sets sensitivity to obstacles during closing (1=max., 99=min.) The autose t feature sets this parameter automatically to a value of 10%. The user can edit this parameter based on how sensitive the door needs to be to obstacles.
oP SPEED	ARGO 10	99	99	Speed during opening	Running speed during opening [%] Sets the running speed that the door must reach during opening, as a percentage of the maximum speed the actuator can reach. Should this parameter be edited, it will be followed by a complete opening/closing cycle for setting purposes (reported by the message "SET" appearing on the display), during which obstacle detection is not enabled.
	ARGO G 18				
cL SPEED	ARGO 10	99	99	Speed during closing	Running speed during closing [%] Sets the running speed that the door must reach during closing, as a percentage of the maximum speed the actuator can reach. Should this parameter be edited, it will be followed by a complete opening/closing cycle for setting purposes (reported by the message "SET" appearing on the display), during which obstacle detection is not enabled.
	ARGO G 18				
d,St.SLoUd	5	99	10	Slow-down distance	Slow-down distance [%] Sets the approach distance to reach the travel limit. This distance is travelled at low speed.
PARt,RL oPEN nG	10	99	40	Partial opening	Partial opening [%] Adjusts partial opening percentage compared to total opening in "Partial open" mode.
Zone	0	129	0	Zone	Zone [] Sets the zone number of the door included in the serial connection for commands via central controllers. Zona=128 not used. Zone=129 Use of optional SCS -IO module.
oUt ProG 1	1	99	50	Output 1 height programmable	The output between terminals 14-15 is activated when the door exceeds the opening percentage set with this parameter (1% = door closed, 99% = door open).
oUt ProG 2	1	99	50	Output 2 height programmable	The output between terminals 4-5 on the SCS-IO optional module is activated when the door exceeds the opening percentage set with this parameter (1% = door closed, 99% = door open).

TABLE "B" - LOGIC MENU - (LoG IC)

Logic	min.	max.	default	Definition	Description
εcR	---	---	OFF	Automatic Closing Time	ON Switches automatic closing on OFF Switches automatic closing off
ibL oPEn	---	---	OFF	Block Pulses	ON The start pulse has no effect during opening. OFF The start pulse has effect during opening.
3 StEP	---	---	OFF	3 Step	ON Switches to 3-step logic. A start pulse has the following effects: door closed: opens during opening: stops and switches on TCA (if configured). door open: closes during closing: stops and opens again OFF Switches to 4-step logic. A start pulse has the following effects: door closed: opens during opening: stops and switches on TCA (if configured) door open: closes during closing: stops and does not switch on tca (stop)
PRE-ALARn	---	---	OFF	Pre-alarm	ON The flashing light comes on approx. 3 seconds before the motors start. OFF The flashing light comes on at the same time as the motors start
hold-to-rUn	---	---	OFF	Deadman	ON Deadman mode during closing: opening operation performed in automatic mode; closing operation continues as long as the control key is held down. (CLOSE). OFF Pulse operation (standard)
Photoc. oPEn	---	---	OFF	Photocells during opening	ON: When beam is broken, operation of the photocell is switched off during opening. During closing, movement is reversed immediately. OFF: When beam is broken, photocells are active during both opening and closing. When beam is broken during closing, movement is reversed only once the photocell is cleared.
εESt Phot	---	---	OFF	Photocell test	ON Switches photocell testing on OFF Switches photocell testing off If disabled (OFF), it inhibits the photocell testing function, enabling connection of devices not equipped with supplementary test contacts.
εESt bAr	---	---	OFF	Safety edge testing	ON Switches safety edge testing on OFF Switches safety edge testing off If disabled (OFF), it inhibits the safety edge testing function, enabling connection of devices not equipped with supplementary test contacts
MAStEr	---	---	OFF	Master/Slave	ON Control panel is set up as the Master unit in a centralized connection system. OFF Control panel is set up as a Slave unit in a centralized connection system.
F iHEd codE	---	---	OFF	Fixed code	ON Receiver is configured for operation in fixed-code mode. OFF Receiver is configured for operation in rolling-code mode.
rAd io PrOū	---	---	ON	Remote control programming	ON Enables wireless memorizing of transmitters: (Fig. K) 1- Press in sequence the hidden key (P1) and normal key (T1-T2-T3-T4) of a transmitter that has already been memorized in standard mode via the radio menu. 2- Press within 10 sec. the hidden key (P1) and normal key (T1-T2-T3-T4) of a transmitter to be memorized. The receiver exits programming mode after 10 sec.: you can use this time to enter other new transmitters. This mode does not require access to the control panel. OFF Disables wireless memorizing of transmitters. Transmitters are memorized only using the relevant Radio menu.
ScR-2ch	---	---	OFF	Gate open light or 2nd radio channel	ON The output between terminals 6-7 on the optional SCS-10 module is set as Gate open light: in this case, the 2nd radio channel controls pedestrian opening. OFF The output between terminals 6-7 on the optional SCS-10 module is set as 2nd radio channel
StArt - oPEn	---	---	OFF	Selection START - OPEN	ON Input between terminals 3-4 works as OPEN. OFF Input between terminals 3-4 works as START
PEd-cloSE	---	---	OFF	Selection PEDESTRIAN - CLOSE	ON Input between terminals 16-17 works as CLOSE. OFF Input between terminals 16-17 works as PEDESTRIAN
chRnūE nOb.	---	---	OFF	Reversing motion	ON Reverses motion of standard rotation (See Fig.I). OFF Standard rotation (See Fig.I).

FIG.1
MANUALE D'USO: MANOVRA MANUALE - USER'S MANUAL: MANUAL OPERATION-
MANUEL D'UTILISATION: MANŒUVRE MANUELLE - BEDIENUNGSANLEITUNG: MANUELLES MANÖVER-
MANUAL DE USO: ACCIONAMIENTO MANUAL - GEBRUIKSHANDLEIDING: MANUEEL MANOEUVRE

ARGO

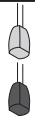
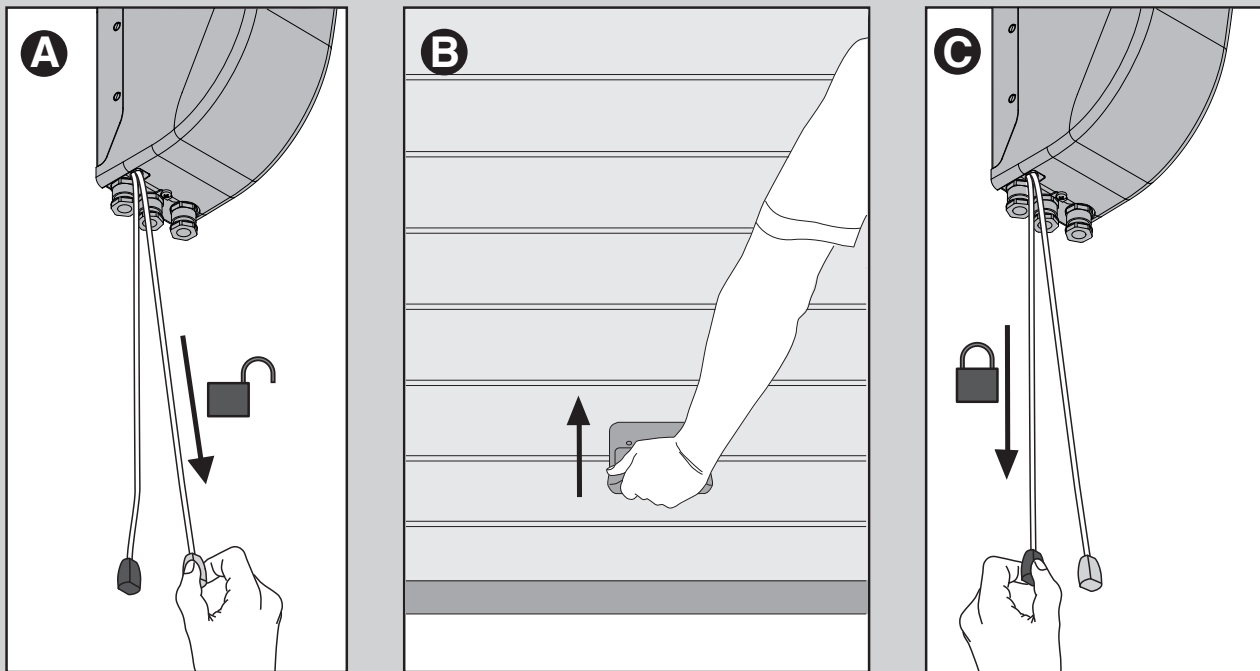

Verde - Green-Vert-Grün-Verde-Groen = 

Rosso-Red-Rouge-Rot-Rojo-Rood = 

Se le porte non sono correttamente bilanciate e l'apertura/chiusura, risultano particolarmente difficoltose, è necessario utilizzare lo sblocco di emergenza RCA/RCAL.
 If doors are not correctly balanced and opening/closing is especially difficult, use the RCA/RCAL emergency release.
Si les portes ne sont pas équilibrées correctement et que l'ouverture et/ou la fermeture s'avèrent particulièrement difficiles, utilisez le déverrouillage d'urgence RCA/RCAL.
 Falls die Türen nicht korrekt ausgewogen sind und das Öffnen/Schließen Schwierigkeiten bereitet, muss die Notfallentsperrung RCA/RCAL verwendet werden.
Si las puertas no están correctamente balanceadas y las fases de apertura/cierre son demasiado dificultosas, es necesario utilizar el desbloqueo de emergencia RCA/RCAL.
 Se as portas não estiverem correctamente equilibradas e a abertura/fecho, forem particularmente dificultosos, é necessário utilizar o desbloqueio de emergência RCA/RCAL.

ARGO G

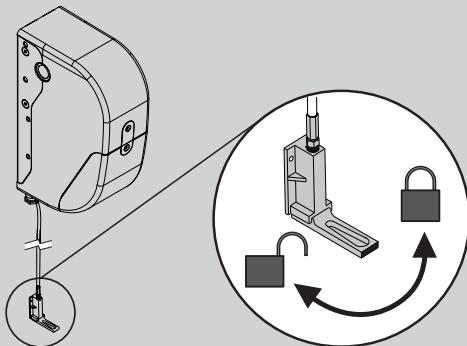

Usare SEMPRE lo sblocco di emergenza RCA/RCAL.

ALWAYS use the RCA/RCAL emergency release.

Utilisez TOUJOURS le déverrouillage d'urgence RCA/RCAL.

Verwenden Sie IMMER die Notfallentsperrung RCA/RCAL.

Usar SIEMPRE el desbloqueo de emergencia RCA/RCAL.

ALTIJD de RCA/RCAL - nooddeblokkering gebruiken.

