

# Firmamatic™

## Rolling Door Opener

### Instruction Manual

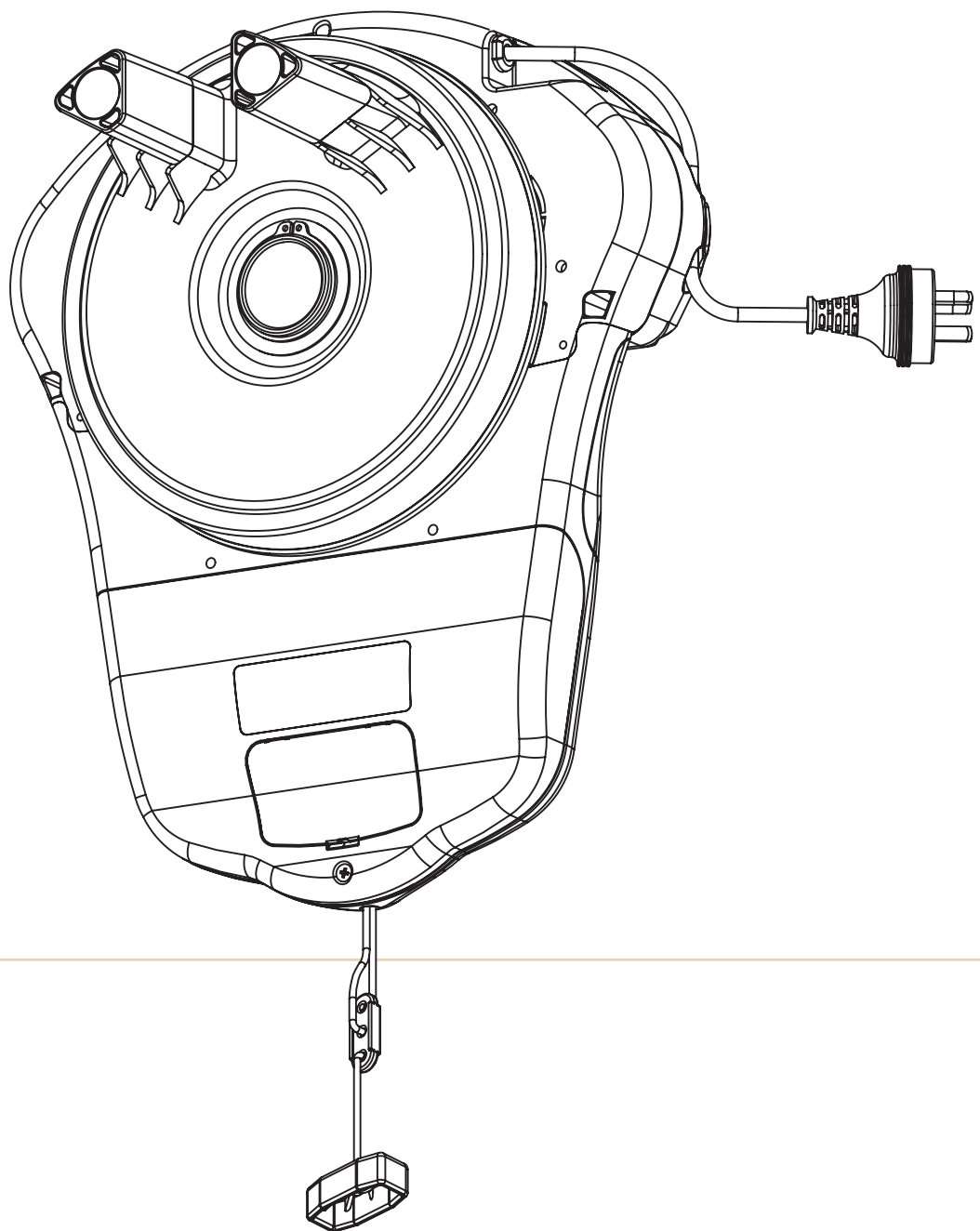

B&D Doors is a Division of B&D Australia Pty Ltd  
ABN 25 010 473 971

P/N 72942



# Firmamatic™

## Rolling Door Opener

<b>Safety Rules</b>	<b>3</b>
<b>System Specification</b>	<b>4</b>
<b>About Your B&amp;D Opener</b>	<b>5</b>
<b>Operating Controls</b>	<b>6</b>
<b>Kit Contents</b>	<b>7</b>
<b>Installation &amp; Setup</b>	<b>8</b>
Pre-Installation Requirements	8
Installation	9
Setting Travel Limits	12
Coding Transmitters	13
Safety Test	15
<b>How To Use Your Opener</b>	<b>18</b>
Remote Control Transmitter	18
Inbuilt Locking Facility	19
Manual Door Operation	19
Power Failure	19
Safety Infra-Red Beam	20
Auxiliary Output	20
<b>Optional Accessories</b>	<b>21</b>
<b>Maintenance</b>	<b>22</b>
<b>Troubleshooting Guide</b>	<b>23</b>
<b>Spare Parts</b>	<b>25</b>
<b>Warranty</b>	<b>26</b>



# Safety Rules















## Please read these important safety rules



These safety alert symbols indicate a personal safety or property damage instruction exists. **READ THESE INSTRUCTIONS CAREFULLY.**



This automatic garage door opener is designed and tested to offer safe service provided it is installed and operated in strict accordance with the following safety rules. Failure to comply with the following instructions may result in death, serious personal injury or property damage.

-  **CAUTION:** If your garage has no pedestrian entrance door, an emergency access device should be installed to allow manual garage door operation from outside in the case of power failure.
-  Position the Garage Door Opener so that the power plug is accessible when inserted into the power outlet (EN 60335-1).
-  This opener should be installed in accordance with relevant Australian Standards.
-  Do not allow children to play with door controls.
-  Keep remote controls away from children.
-  Watch the moving door and keep people away until the door is completely opened or closed.
-  Activate the opener only when the garage door is in full view, free of obstructions and with the opener properly adjusted.
-  Keep garage door balanced. Sticking or binding doors must be repaired. Garage doors, door springs, brackets and their hardware are under extreme tension and can cause serious personal injury. Do not attempt any garage door adjustment. Do not use if repair or adjustment is needed. Call for professional garage door service.
-  Install optional door control button in a location where the garage door is visible, but out of the reach of children at a height of at least 1.5m.
-  Disconnect electric power to the garage door opener when cleaning or carrying out other maintenance.
-  Garage doors needing over 400N of force to move must have Safety Infra-Red Beams installed.
-  Do not wear rings, watches or loose clothing while installing or servicing a garage door opener.
-  This opener is not suitable for commercial, industrial or common entry applications.
-  To avoid serious personal injury from entanglement, remove all unnecessary ropes or chains and disable any equipment such as locks which are not needed for powered operation.
-  Installation and wiring must be in compliance with your local building and electrical codes. Connect the power cord only to properly earthed mains. If an extension lead is used, make sure it is a 3 core lead and approved to 7 amp capacity.
-  If the supply cord is damaged, it must be replaced by the manufacturer or its service agent or a similarly qualified person in order to avoid a hazard.
-  This opener is a plug in domestic appliance and is designed for indoor use only. It must be installed in a dry position that is protected from the weather.
-  The opener is not intended for use by young children or infirm persons without supervision.



**WARNING! It is vital for the safety of persons to follow all instructions. Save these instructions.**

B&D Doors to the extent that such may be lawfully excluded hereby expressly disclaims all conditions or warranties, statutory or otherwise which may be implied by laws as conditions or warranties of purchase of a B&D Doors Garage Door Opener. B&D Doors hereby further expressly excludes all or any liability for any injury, damage, cost, expense or claim whatsoever suffered by any person as a result whether directly or indirectly from failure to install the B&D Doors Garage Door Opener in accordance with these installation instructions.

# System Specifications

## Factory default settings

	Default	Step	Maximum
Courtesy light time	3 minutes (approx.)	-	-
Obstruction force margin	2	1	11

## Technical specifications

Mains supply	230V - 240Va.c. 50Hz
Standby power	2.2 Watts
Rated input power	240 Watts
Motor type	24V DC Permanent Magnet
Maximum door size:	16.5m <sup>2</sup> (5500mm width x 3000 mm height )
Short term peak force	550N (55kg)
Rated Lifting force	450N (45kg)
Recommended force for manual operation	150N (15kg)
Rated operating time	4 minutes
Opener's max limit travel	3.0 turns of door drum wheel
Transmitter / Receiver type	Tri-Tran™
Receiver code storage capacity	8 x 2 button
Coding type	Code hopping
Number of code combinations	Over 4.29 billion random codes
Code generation	Non-linear encryption algorithm
Transmitter battery	CR2032 (3 Volts)
Courtesy light	LED (Light Emitting Diodes), two modules
Controller fuse	10 A slow blow

NOTE: The door must be well balanced. A person should be able to lift the door up manually with very little effort in case of emergency. Intermittent operations may occur in areas which experience very strong winds. Strong wind puts extra pressure on the Door and tracks which may in turn trigger the safety obstruction detection system intermittently.

# About Your B&D Opener

Thank you for choosing a B&D automatic garage door opener. This automatic garage door opener has been designed and developed in Australia by B&D Doors.

The technically advanced construction of this Firmamatic™ opener ensures you enjoy the following benefits:

## Warranty

Two (2) year/5,000 cycles full parts and labour warranty on motor, electronics and mechanical components of the opener when installed by an Authorised B&D Dealer (conditions such as having the garage door serviced annually also apply).

## Tri-Tran Frequency Hopping Technology

Every time a transmitter is used, it simultaneously sends a signal over three different frequencies, reducing the chance of interference from other radio frequency sources.

## Code Hopping Technology

Every time a transmitter is used, a new security code is generated from over 4.29 billion possible combinations.

## Multi-Channel Transmitter

Multi-channel transmitters allow you to operate other devices such as an adjoining garage door or automated gate from the same handy unit.

## Soft Start/Soft Stop

The opener eases into and out of each cycle for smooth and quiet operation, and also to reduce wear on the door and opener.

## Warranty Expired Indicator

When the opener reaches the number of cycles covered by warranty, the courtesy light will flash 10 times after each cycle, for the next 20 cycles, to indicate this. It can be reset by pressing the LIMIT SET button while the courtesy light is flashing.

## Safety Reversing System

Automatic safety reverse ensures personal protection from death or serious injury if trapped under a door while closing. Safety reverse force can be adjusted for environmental conditions, for example windy areas, etc.

## LED Courtesy Light

Taking advantage of the latest advances in Light Emitting Diode (LED) technology, the opener features two light modules consisting of ten LEDs each, which produces a brilliant white light to illuminate the garage.

The LED courtesy light automatically switches on for approximately 3 minutes (time programmable) when operating the door. This can also be programmed to turn on and off from a remote control transmitter.

## Manual Release

Emergency manual release handle for manual operation of the door in the event of a power failure.

## Memory Retention

In case of a power failure the opener does not lose the transmitter codes or limits settings.

## Self Locking

No need to manually lock your garage door, as the opener 'positively' locks the door when closed.

## Periodic Maintenance Indicator

The service LED will illuminate to indicate that periodic maintenance is required. Contact your dealer/installer for service.

## Service Fault Indicator

Flashing LED's on the control panel easily identify operational problems or service requirements.

## Dynamic Door Profiling

Automatically compensates for changes in door operating characteristics.

## External Antenna

An external antenna can be connected - for sites where radio reception is a problem.

## Auxiliary Output

You can program a spare button of you remote control transmitter to operate this output to control items that can be switched using a momentary close.

# Operating Controls

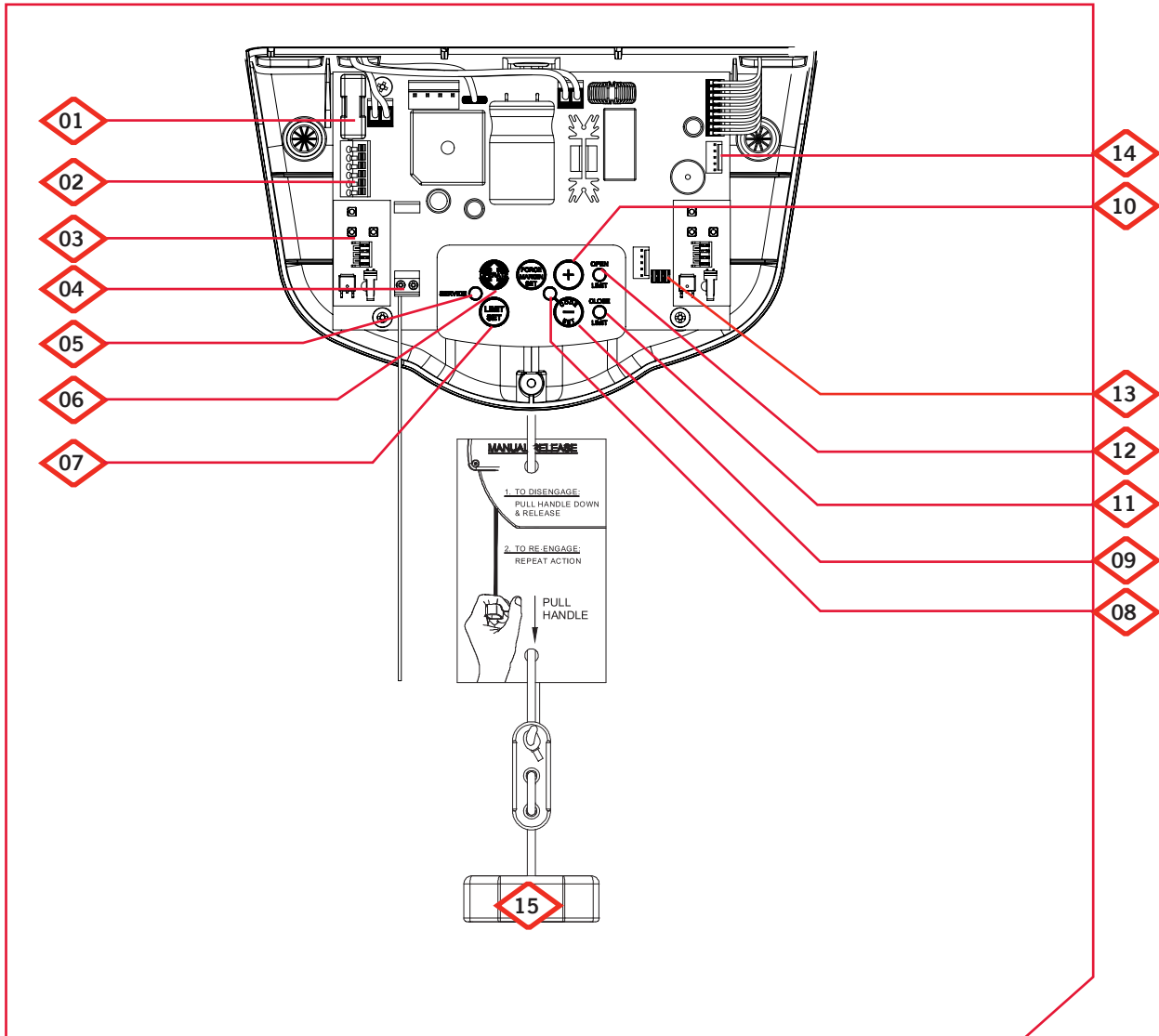

- 01. Fuse
- 02. Terminal block:
  - 30v PWR
  - P.E Beam
  - P.E 0V
  - GND
  - OPERATE
  - AUX OUT
- 03. LED light array
- 04. Antenna terminal
- 05. SERVICE LED indicator (yellow)
- 06. OPERATE button (blue)
- 07. LIMIT SET button (black)

- 08. CODE SET LED indicator (red)
- 09. MINUS (-) and code set button (red)
- 10. PLUS (+) button (green)
- 11. CLOSE LIMIT LED indicator (red)
- 12. OPEN LIMIT LED indicator (green)
- 13. Jumpers:
  - OPT 1
  - OPT 2
- 14. Universal programmer connector
- 15. Manual release handle

# Kit Contents

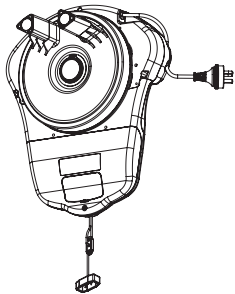

1.

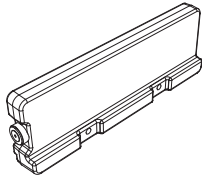

2.

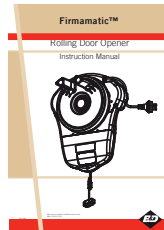

3.

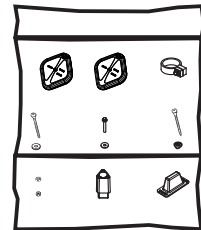

4.

1. Powerhead
2. Weight Bar
3. Instruction manual and warning labels
4. Installation and Operating Items, including:
  - a. Qty 2 Keyring remote control transmitters
  - b. Qty 2 Screw M4 x 50
  - c. Qty 2 3/16x1/2 flat washers
  - d. Qty 2 5/32 shakeproof washer
  - e. Qty 2 Nut M4 hex
  - f. Qty 2 Hex serration head screw M6x45
  - g. Qty 2 Flat washer 107D 6.4x20.5x1.6
  - h. Qty 2 Extension fork 58L
  - i. Qty 1 Collar kit
  - j. Qty 2 Screw 10x32 self tapping
  - k. Qty 2 Washer 6.4x20.6x1.2 to pin the door curtain
  - l. Qty 2 Cover with D/S tape



a. Qty 2



i. Qty 2



b. Qty 1



f. Qty 2



j. Qty 2



c. Qty 2



g. Qty 2



k. Qty 2



e. Qty 2



h. Qty 2

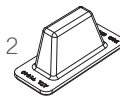

l. Qty 2

# Pre-Installation Requirements

Fig.01

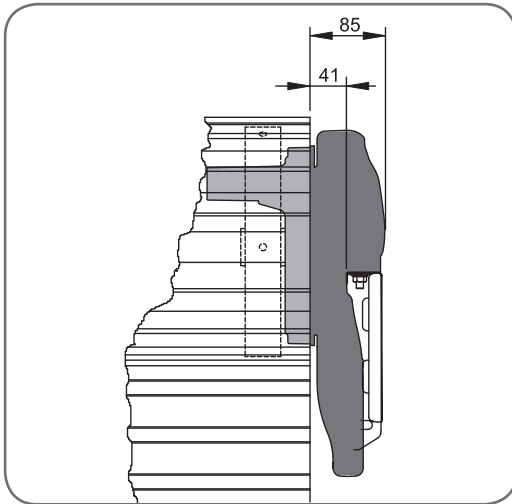
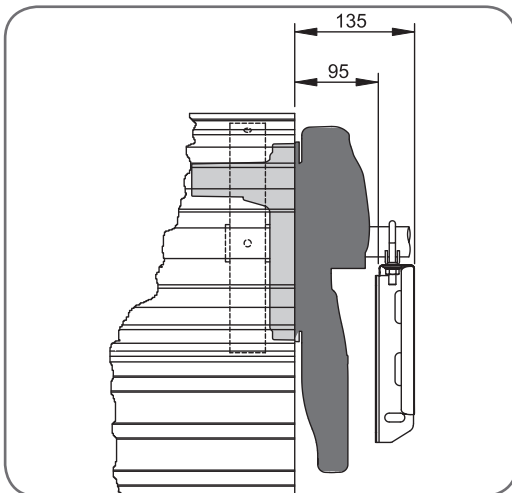

Fig.02



**WARNING!** Incorrect installation can lead to severe injury - **FOLLOW ALL INSTALLATION INSTRUCTIONS.**

## Door Operation

The door must be in good operating condition. The maximum effort to move the door up or down, from stationary, should not exceed 150 Newtons (15kg force) at the bottom rail. The recommended force is 70N (7kg) for manual operation.

Lift the door to about halfway. When released, the door should stay in place supported entirely by its springs. Also raise and lower the door to check for any binding or sticking.

The door may need to be serviced to meet these requirements – refer to the door manufacturer's servicing instructions or contact an authorised dealer.

## Unsuitable Door Types

The fitting of an opener to doors with removable mullions is not recommended.



**IMPORTANT NOTE** - The opener should not be installed on any door incorporating a wicket door.

## Position

The opener can be installed on either the right hand or left hand side of the door (when viewed from inside the garage). The opener is factory set for right hand side installation.

This opener must be installed in a dry position that is protected from the weather. Moisture or corrosion damage is not covered by the Warranty.

## Power Supply

A properly earthed 3 pin single-phase power supply is required.



**WARNING!** A portable power generator is not recommended. The opener may appear to malfunction due to spikes, surges and fluctuations in the generated voltage.

## Sideroom

The minimum sideroom required from the edge of the door curtain is 41mm to the inside of the door bracket, and 85mm to the wall (**Fig. 01**).

The recommended side room from the edge of the door curtain is 95mm to the inside of the door bracket, and 135mm to the wall (**Fig. 02**).

**NOTE:** Door Axle Diameter must not exceed 35mm.



# Installation

## Step 1 - Preparation

- a. Check the door's operation:
  - i. The door must travel smoothly and be easy to operate by hand.
  - ii. Operating force on the bottom rail should be approximately 70N (7kgs) force.
  - iii. Adjust any tight or twisted guides/tracks.
  - iv. Clean the guides if there is any oil or wax present using a suitable white spirit. The only lubricant suitable for use on door guides is silicon spray. DO NOT use WD-40, RP-7, petroleum grease, or similar.
- b. Install the locking bar covers if there are locking bar holes in the guides. **(Fig.03)**



**IMPORTANT NOTE** - Do not lock your door with the locking bars after installing the opener. Remove or disable the lock using wire or cable ties. Security is not affected as the opener has an inbuilt locking facility.

- c. Affix the warning labels supplied with this opener in a prominent place where they are clearly visible.
- d. Choose the side where the opener will be installed ensuring there is sufficient sideroom.

## Step 2 - Fit the Weight Bar

The weight bar must be fitted to the bottom-centre for proper operation of the opener.

### If the door has a handle:

- a. Remove the door handle.
- b. Fit the weight bar and refit the handle using the new fasteners provided **(Fig.04)**.

### If the door does not have a handle:

- a. Locate the centre of the door at the bottom rail **(Fig.05)**.
- b. Place the weight bar at this point (there is a centreline marked on the weight bar) and mark the two positions where the fasteners will go.
- c. Drill the two 4.5mm holes in the door and fit the weight bar using the new fasteners provided. **(Fig.06)**.

Check that the door is still balanced and smooth to operate. If it is not, then the door may require servicing (refer to door manufacturer's instructions).



**WARNING!** The door and its springs are under significant tension. Adjustments should only be carried out by experienced persons, as this function can be dangerous if not performed under strict safety procedures.

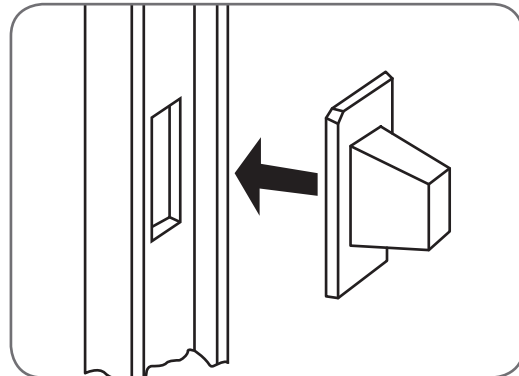

Fig.03

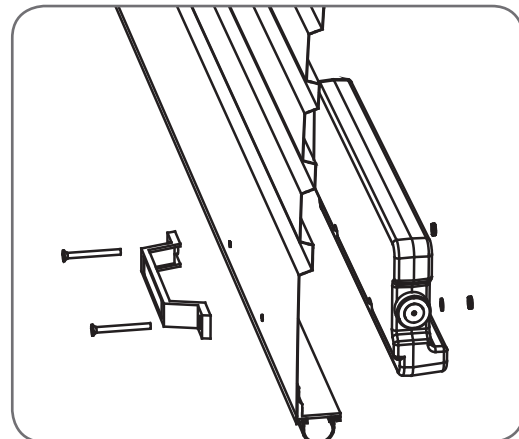

Fig.04

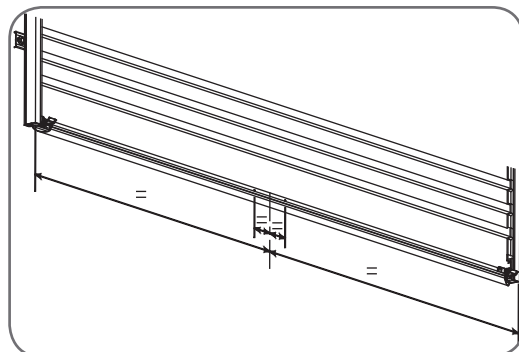

Fig.05

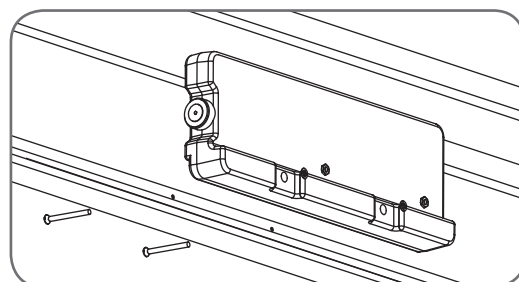
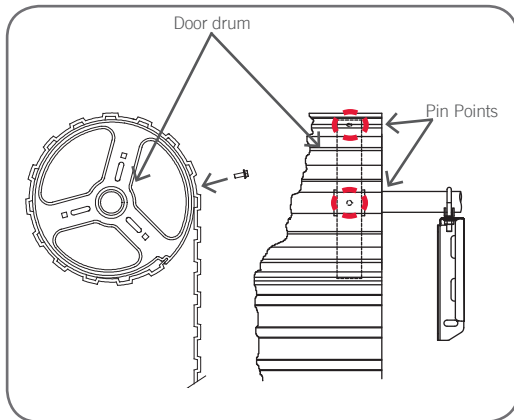

Fig.06

# Installation

Fig.07



## Step 3 - Pin the Door Curtain

Pinning the door curtain to the door drum maintains security when the opener closes and locks.

- Fully close the door.
- Mark drill holes at both ends of the drum (**Fig. 07**).
- Drill holes using a 3.2mm (1/8") drill bit. Open the door slightly for easier access, if necessary.
- Fit a 10 x 32mm screw and washer to each end. This screw should be positioned as low as possible, but make sure that it does not alter the curtain's normal approach to the guide (lead-in angle).

**NOTE:** Make sure that the screws do not project into the area where the internal gear will fit.

## Step 4 - Fitting the Opener

- At the end opposite to where the opener will be fitted, check that the U-bolt is tightened securely. Fit the anti-coning collar (supplied) to the axle flush with the door drum.
- Open the door completely and tie safety ropes around the door roll approximately 300mm from each end. Do not tie the ropes too tight as damage to the curtain may ensue.
- At the end where the opener is to be fitted, support the door with a ladder or suitable prop.



**WARNING!** Make sure the support is snug under the door, is stable and will not move.

- At the end where the opener will be fitted, use masking tape or pen to mark the position of the U-bolt in the door bracket and the position of the door bracket on the wall. This will assist in reassembling.
- Remove the U-bolt (or bolts) and saddle from the door bracket.
- Remove the door bracket allowing the door to rest on the support (**Fig. 08**).



**NOTE -** For minimum sideroom installations, the door may have to be taken down.



**WARNING!** The opener must not be used with a door incorporating a wicket door.

Fig.08

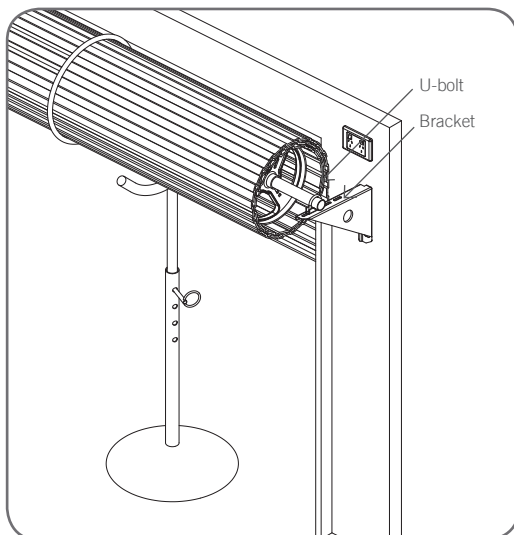

# Installation



**WARNING!** The opener should not be installed where the door opens over a public footpath or roadway.

## Step 5 - Assemble the Internal Gear

- Insert the two forks into the ring gear (**Fig. 09**).
- Secure with M6x45 hex serration head screw and washer.

## Step 6 - Mounting the Opener

- If the internal gear does not rotate freely, switch the opener to manual by pulling the disengagement handle down (there will be a click). The ring gear can now be rotated by hand.
- Slide the opener over the door axle and into the drum of the door (**Fig. 10**).
- Ensure the internal gear is pushed in as far as possible (without interfering with the door curtain). One of the door drum's wheel spokes must be completely between the opener's drive forks.
- Re-attach the door bracket using your reference marks as a guide and tighten the bolts. Ensure that the slots in the mounting bracket of the opener align with the slots in the door bracket. If not, the door bracket may have to be relocated (**Fig. 11**).

If the bracket cannot be relocated, the opener may be fitted onto the axle using the opener's saddle and U-bolt as follows:

- Using your reference marks as a guide, sit the opener on the door mounting bracket. Secure with the opener's U-bolt and saddle and tighten firmly.
  - Adjust the door position (if necessary) on the brackets so that the door feeds smoothly into the guides. Make sure that the centre of the door doesn't hit the lintel and that the curtain is not pushed forward hard into the guide.
- Remove the support and safety ropes (**Fig. 11**).



**IMPORTANT NOTE** - If the manual release handle is more than 1.8 metres from floor level when the opener is installed, extend the handle to a height less than 1.8 metres.

- Connect the power cord to a suitable power point, but **DO NOT SWITCH ON**. Secure the power cord away from any moving object (e.g. the door) with the cable clip supplied.
- With the opener still disengaged, pull the door up and down to make sure it runs freely.

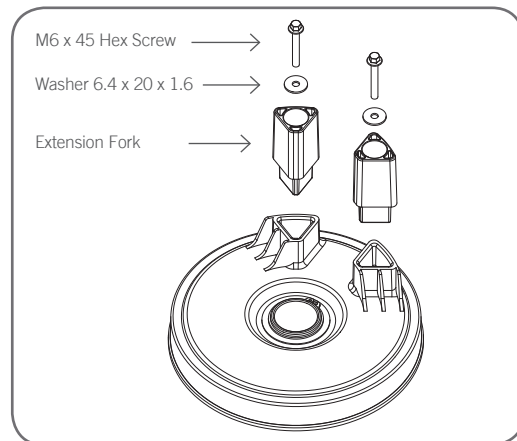

Fig.09

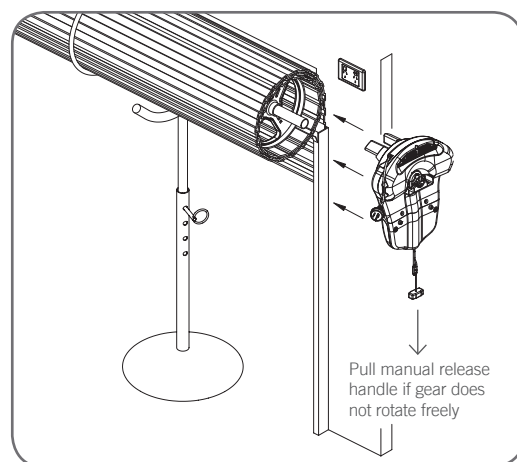

Fig.10

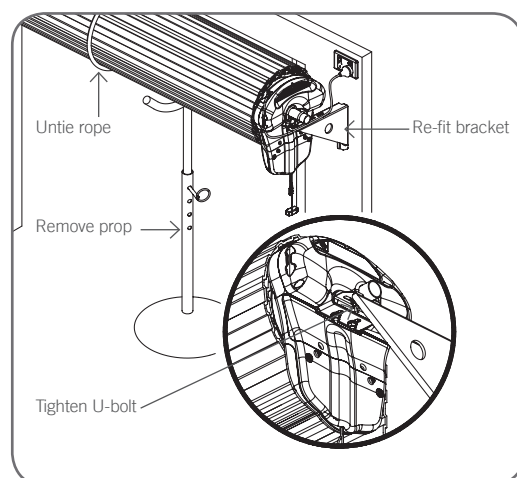
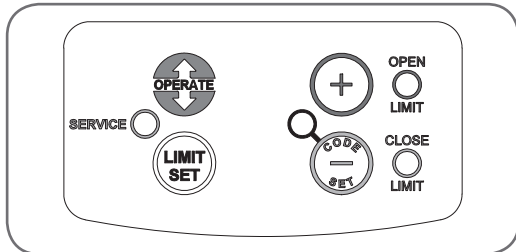

Fig.11

# Setting Travel Limits

Fig.12



**WARNING!** Use caution when operating the manual release with the door open since it may fall rapidly due to weak or broken springs, or an improperly balanced door.



**CAUTION!** Do not disengage the opener to manual operation with children, persons or any objects including motor vehicles within the doorway.

## Step 7.1 - Setting Travel Limits

**NOTE:** If Infra-Red Safety Beams are to be used they must be installed before setting the travel limits.

- Move the door to half way open. If necessary, disengage the opener by pulling the red handle down.
- Re-engage the opener by pulling the red handle down.
- Turn on the power to the opener. The CLOSE LIMIT LED will be flashing.
- Press and hold the MINUS (-) button - the door should start closing (**Fig. 12**).

If the door opens, release the MINUS (-) button and press the OPERATE button once to change the motor's direction. Press the MINUS (-) button again to close the door.

- Release the MINUS (-) button when the door is near the desired closed position. Single presses of the MINUS (-) button will "inch" the door closed.

If the door overshoots, press the PLUS (+) button to move the door in the open direction.

- When the door is at the desired close position, press the LIMIT SET button to record the Close limit position. The OPEN LIMIT LED will now flash.
- Press and hold the PLUS (+) button to open the door.
- Release the PLUS (+) button when the door is near the desired open position. Single presses of the PLUS (+) button will "inch" the door open.

If the door overshoots, press the MINUS (-) button to move the door in the close direction.



**WARNING!** Once the next step is performed, the door will automatically close and open. Keep persons and objects clear of the door until it stops and the opener sounds a beep.

- Press the LIMIT SET button to store the open limit. Please read the above warning.

## Step 7.2 - Resetting Travel Limits

To reset the limits, press and hold the LIMIT SET button for 6 seconds until the Close Limit LED flashes quickly. If no action is taken within 30 seconds, the opener will beep and return to normal operating mode and restore the original limit settings.

# Coding Transmitters

## Step 8.1 - Storing the Transmitter Code

The opener can only be operated from remote control transmitters that have been programmed into its memory. Up to eight (8) codes can be stored in the memory.

- Ensure that the battery is inserted in the transmitter.
- Press the CODE SET button and release. The CODE SET LED will illuminate to indicate the opener is in Code Learn mode. If a valid code is not stored within 15 seconds, the opener will exit Code Learn (**Fig. 13**).
- Press the transmitter button (one of two) that you want to control the door. The CODE SET LED will flash.
- Press the same transmitter button again. The CODE SET LED will illuminate for one second then go out.
- The transmitter button is now coded - press to test.

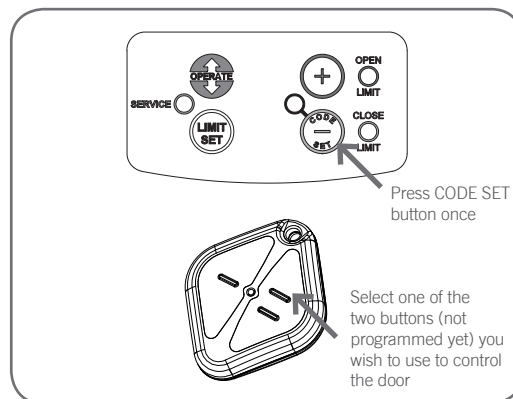

Fig.13

## Step 8.2 - Setting the Transmitter to Operate the Courtesy Light Independently of the Door

Although the courtesy light comes on with each operation of the opener, it may also be controlled by a transmitter without operating the door.

- Press the CODE SET button twice - The CODE SET LED and courtesy light will both illuminate (**Fig. 14**).
- Press a transmitter button not already coded into the receiver - the CODE SET LED will begin to flash.
- Press the same transmitter button again. The CODE SET LED will illuminate for one second then go out.
- The transmitter button is now coded - press to test.

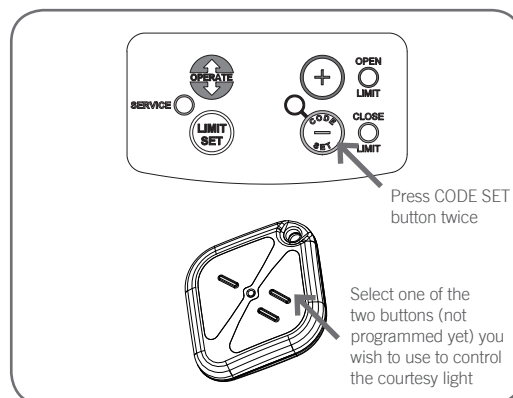

Fig.14

## Step 8.3 - Setting the Transmitter to Operate the Auxiliary Output

It is possible to operate other devices (e.g. alarm systems) using one of the spare buttons of a multi-channel transmitter coded into the Auxiliary Output feature.

- Press CODE SET button four times. The CODE SET LED will illuminate and the courtesy light will flash quickly (**Fig. 15**).
  - Press a transmitter button not already coded into the receiver - the CODE SET LED will begin to flash.
  - Press the same transmitter button again. The CODE SET LED will illuminate for one second and then go out.
- Step 8.1 - Storing the Transmitter Code

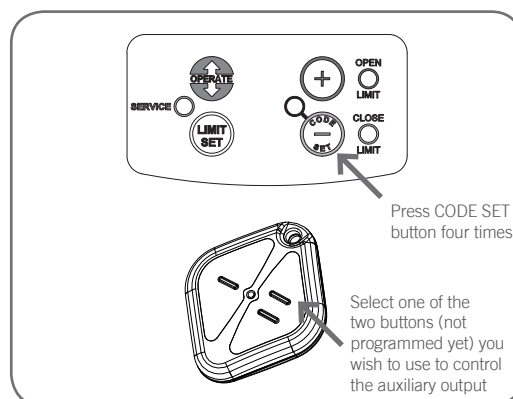
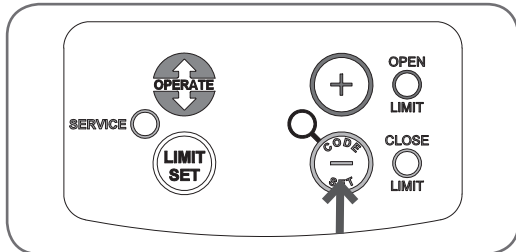

Fig.15

# Coding Transmitters

Fig.16



## Step 8.4 - To Erase Programmed Codes

If the CODE SET button is pressed and held for 6 seconds, the CODE SET LED will blink rapidly for one second to indicate that all programmed codes have been erased. (Fig. 16)

## Step 8.5 - Installation of the Wall Mounted Transmitter

- Mount the transmitter in a convenient location, yet out of reach of children and at least 1.5m off the ground (Fig. 17).
- Make sure the door is visible from this location.
- To set the transmitter codes refer to Step 8.1.

Fig.17

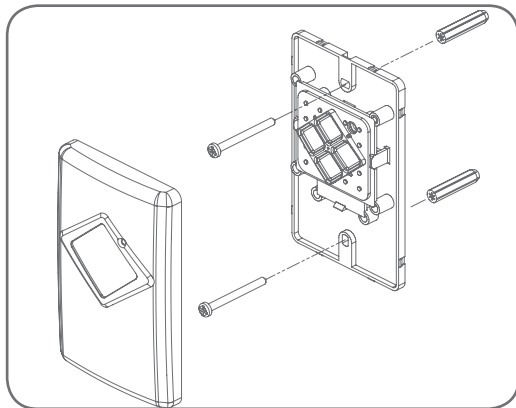

# Safety Test

## Step 9.1 - Door Closing Test

- Ensure that the door is open.
- Place a 40mm obstacle flat on the floor under the middle of the garage door (**Fig. 18**).
- Operate the door in the close direction; the door must reverse on hitting the obstruction. The CLOSE LIMIT LED flashes to indicate an obstruction while closing.
- If the door fails to reverse, remove the obstacle and reset the door travel limits as per Step 7 on page 12.
- Place the 40mm obstacle on the floor under the garage door and then re-test.

**IMPORTANT NOTE:** If the test fails again, there may be a problem with your door or opener - put the opener into manual operation, only operate the door by hand and phone for service.

## Step 9.2 - Door Opening Test

- Ensure that the door is closed.
- Operate the opener to open the door.
- While the door is opening (approximately 1 metre off the floor) hold the bottom edge of the door with your hands. When a reasonable downward force is exerted, the door should halt.
- The OPEN LIMIT LED will flash to indicate an open obstruction has been detected.
- If the door fails to halt, operate the opener for five cycles and then re-test. If the test fails again you will need to call for service.

**NOTE:** Ensure the door opens and closes properly.

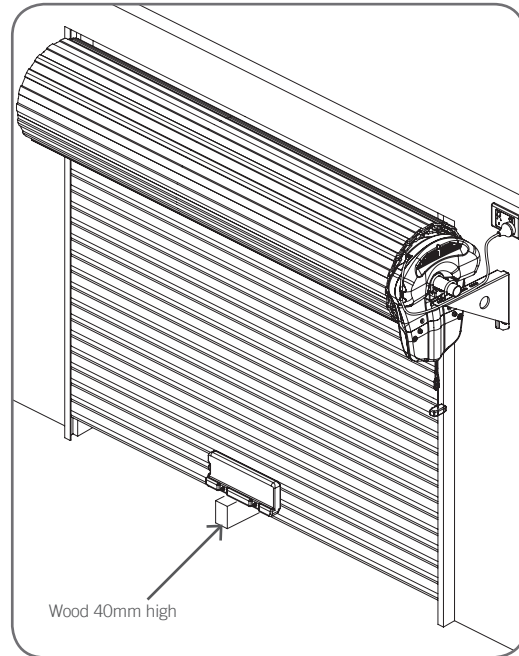

Fig.18



**IMPORTANT NOTE** - The safety system is designed to prevent entrapment or serious injury. It relies upon physical contact with objects in the path of the door. The safety system alone may not prevent cosmetic damage to motor vehicles or property.



**IMPORTANT NOTE:** The use of Safety Infra-Red Beams is recommended on all installations of automatic garage door openers



**WARNING:** Doors requiring over 400N of force to move must have Safety Infra-Red Beams fitted for safety.



**IMPORTANT NOTE** - Permanently fix the label warning against entrapment and manual operation in a prominent place or near any fixed controls. After installation, ensure that the mechanism is properly adjusted and that the opener reverses when the door contacts a 40mm high object placed on the floor under the garage door.

# Accessories

Fig.19

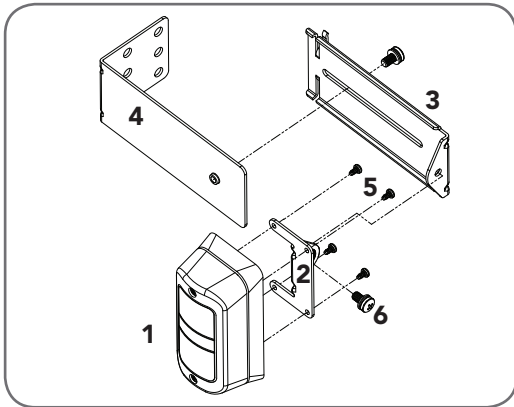

**IMPORTANT NOTE** - The Safety Infra-Red Beam must be installed and connected before the travel limits are set - See Step 7.

## Safety Infra-Red Beams

The Safety Infra-Red Beams extends across the garage door opening. This Infra-Red Beams is designed to detect an obstruction while the door is closing and to send a signal to the garage door opener to reverse or stop the door movement. For **ADDITIONAL PROTECTION** B&D **STRONGLY** recommend the fitting of a Safety Infra-Red Beam.

## Fitting Photo Electric (PE) Beams

- Attach the mounting bracket (4) to adjustment bracket (3) with the pan head screw (6) (supplied). (Fig. 19)
- Attach the PE 2000TS bracket (2) to PE beam transmitter (IR-200TS-TX) with four tapite screws (m3x5) and attach the other side to adjustment bracket (3) with the pan head screw (6) (supplied).
- Repeat steps a and b to assemble the PE Beam receiver (IR-200TS-RX).

Locate the Photo Electric (PE) Beams in a strategic location in the doorway. B&D recommend that the sensor is placed 150 mm above the floor level and as close as possible to the door opening. Connect as per the wiring diagram (Fig. 21).

Fig.20

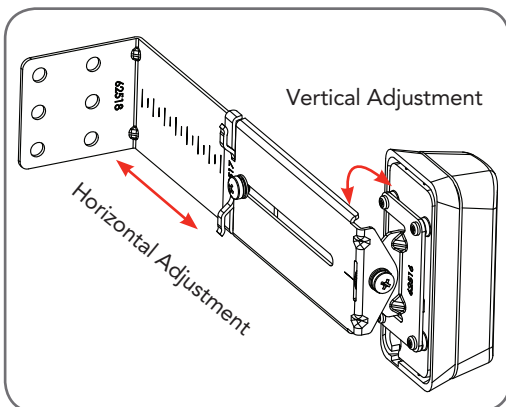

Use 2.2 kilo ohm resistor with the colour code red, red, red and gold on the PE Beams receiver between the V- and NC terminals as shown in (Fig. 21).

## Alignment

- Power up the PE Beams. The green LED on the transmitter and red LED on the receiver should turn ON to indicate power is present.
- If the receiver is connected to power and the red LED is on while the green LED is on, the transmitter and receiver are not aligned.
- Make horizontal and/or vertical adjustment on the transmitter and/or receiver until the red LED turns off on the receiver, indicating alignment (Fig. 20).

## Safety Infra-Red Beams Operation And Testing

The safety beam has no effect on an opening of the door. Breaking the safety beam prevents closure of an open door and will also stop and re-open a closing door.

Fig.21

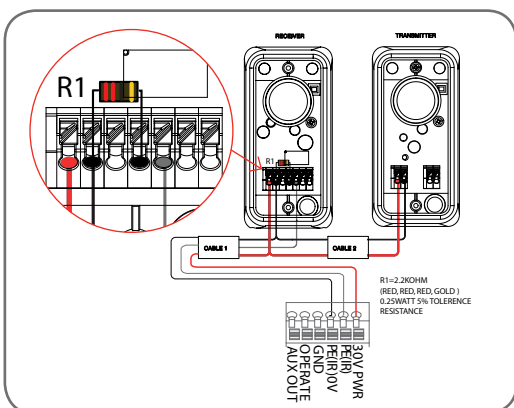

**CAUTION!** The location of the beam and manner in which it is installed might not give safety protection at all times. Check to make sure that the height of the beam and type used give maximum protection possible.



# Accessories

## Remote Aerial

Some sites cause poor radio reception. Particularly problematic areas are those where there is a large amount of metal, like an all steel garage, or an underground car park with large masses of steel reinforced concrete. These issues, and others, can create radio reception issues.

Poor radio reception will be noticed by a reduction in the operating range of the transmitters.

You can evaluate whether fitting an external aerial will benefit as follows:

- test the maximum operating range of the transmitter with the garage door closed; then
- test the maximum operating range of the transmitter with the garage door open.

If the range improves when the door is open, you can install a remote aerial kit to improve reception.

Mount the aerial to a suitable location on the outside of the garage. Similar to a television aerial, the better the mounting position, the better the reception will be. Where possible, mount the aerial as high as possible, away from masses of metal and in a line of sight position to where you normally use your transmitter. Refer to **(Fig. 22)** for connection.

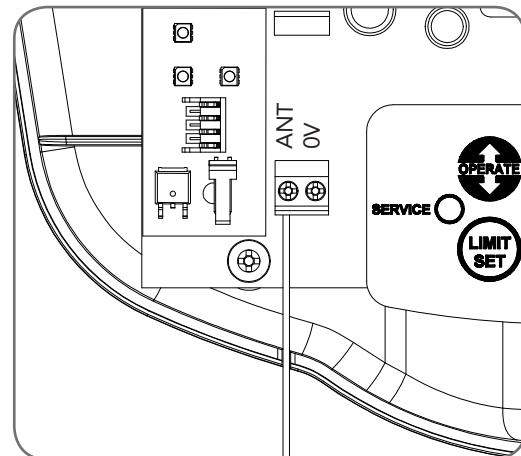

Fig.22

## Terminal Block

A variety of wired accessory items can be connected to the terminal block such as Safety Infra-Red Beams, Electric Key Switch, and more.

The terminal block also features an auxiliary output for controlling other devices from your transmitter. These can include: an alarm system, external lighting, or an automatic gate.

Terminal connections are as follows **(Fig. 23)**:

1. 30V PWR (+ve)
2. IR BEAM (Safety IR Beam Input)
3. IR BEAM (0V)
4. GND (Ground, Common)
5. OPERATE (Open/Stop/Close trigger)
6. AUX OUT (Auxiliary output trigger)

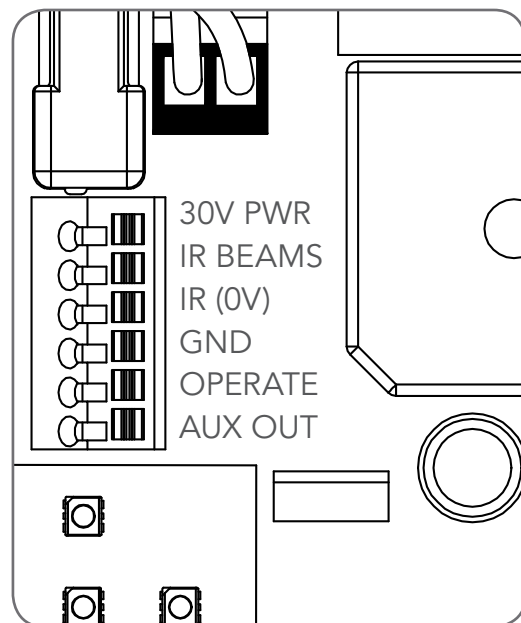
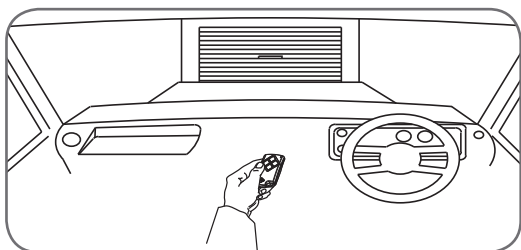

Fig.23

# How To Use Your Opener

Fig.24



For maximum efficiency of your opener, your garage door must be in good operating condition.

The door should be serviced annually by a Authorised Dealer (refer to Warranty conditions on page 25).



**WARNING!** Activate the opener only when the door is in full view, free of obstructions and with the opener properly adjusted. No one should enter or leave the garage while the door is in motion. Do not allow children to play near the door.



**DANGER!** This opener is a mains voltage plug in domestic appliance and there are no user serviceable parts inside this opener.

## Transmitter

- To operate the opener, press the programmed transmitter button until your door begins to move (usually 2 seconds). Make sure you can see the door when you use the transmitter.
- If you are in a vehicle you should aim the transmitter through your windscreen (**Fig. 24**).
- Check that the door is fully closed before you drive away.
- If you press the transmitter whilst the door is moving, the door will stop. The next press of the transmitter will move the door in the opposite direction.

The transmitter may also be programmed to operate the following features (see pages 13 for full details):

- to turn the courtesy light on and off without operating the door,
- to activate the Auxiliary Output.

**NOTE:** Additional transmitters may be purchased at any time.

# How To Use Your Opener

## Inbuilt Locking Facility

**DO NOT** lock your door with the locking bars when your opener is engaged. This opener has an inbuilt locking facility. With the opener engaged, your door will be locked whether the power is on or off.

## Manual Door Operation



**CAUTION!** When operating the manual release while the door is open it may fall rapidly due to weak or broken springs, or due to it being improperly balanced.



**CAUTION!** Do not disengage the opener to manual operation with children/persons or any objects including motor vehicles within the doorway.

To disengage the opener from the door, (preferably with the door in the closed position) pull down on the red manual release handle – you will hear a ‘click’ (Fig. 25).

You may manually open or close the door any time without affecting the pre-set limits.

Pulling down on the red handle again (click) will re-engage the opener, i.e. automatic operation.



**WARNING!** When the opener is manually disengaged, the door is no longer locked. To lock the door manually, re-engage the opener after the door is closed.

## Power Failure

When there is a power failure, the opener will be unable to automatically open or close your garage door. To use your door whilst there is no power, you will need to disengage the opener and use the door manually – see Manual Operation above.

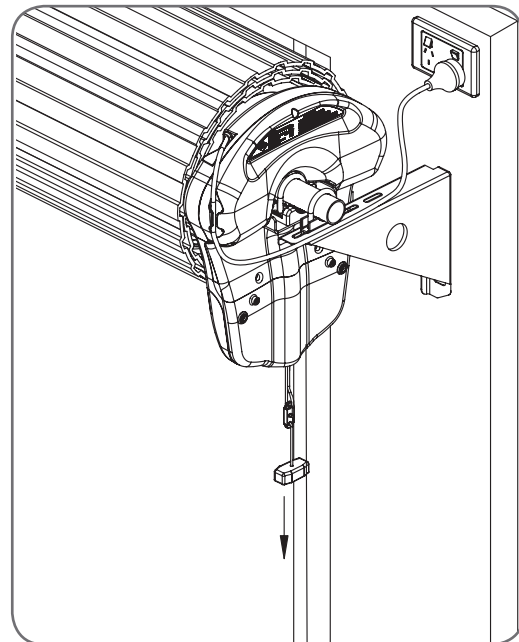

Fig.25

# How To Use Your Opener

## Safety Infra-Red Beam Option

A Safety Infra-Red Beam Kit may be fitted to this opener.

- When this option is fitted, the operation of this device is such that if an object (i.e. car, child, etc.) blocks the Infra-Red beam, then the garage door opener will not close the door automatically.
- If the Safety Infra-Red Beam is fitted but not operating correctly, then the door once opened automatically, will not close automatically. The door may be closed by reverting to manual operation – see Manual Operation. Refer to the Diagnostic Codes section of this Instruction Manual.

## Remote Control Transmitter Battery

When necessary, remove the cover and replace the battery with the same type. Dispose of the old batteries properly.

## Courtesy Light

The Courtesy Light will illuminate for approximately 3 minutes each time the door is operated automatically.

Spare button of the two channel remote control transmitters or an entry keypad can be programmed to turn the light on and off by remote control.

## Auxiliary Output

This function allows the opener to operate other devices such as external lights, or an alarm system.

To use this function, a spare button of a two channel remote control transmitter or an entry keypad, must be programmed to operate the Auxiliary Output feature.



# Optional Accessories

There is a range of additional accessories for your added convenience and security.

- **Safety Infra-Red Beams** - Part no 61903. Gives additional protection against the door closing onto your property or person. Simply breaking the beam “reverse” the door toward open position!
- **Keyring Transmitter** - Part no 62730. Ideal for personal use when entry into the house may be via the garage.
- **Transmitter Wall Button** - Part no 70233. Allows you to operate the opener within 10 metres of the door. Ideal for mounting inside the house.
- **Combo Access Kit** -Part no 059009 Key switch function will open the door without a transmitter. Can be used to manually disengage the opener, and recommended when the garage door is the only access to the garage.
- **Remote Aerial Kit** - Part no 062177 For sites where radio range may be reduced.

Contact your Approved Dealer for installation of these accessory items.



When installing any accessories, always follow the instructions included with the product.



Only B&D accessories purchased from an Authorised Dealer offer the highest quality and assure you of trouble free opener operation.

# Maintenance

## Maintenance

The SERVICE LED and three beeps at the start of each cycle will indicate the requirement for a service and/or adjustment. To reset the SERVICE LED when the door is serviced, reprogram the Door Travel Limits and the Door Travel Force – on completion, press and hold LIMIT SET button for three (3) seconds while the service light is on, the SERVICE LED will go out.

Whilst your opener does not require any periodic maintenance, the door that it is fitted to does. Your garage door is a large, heavy, moving object and should be tested regularly to ensure it is in good condition. A poorly maintained door could cause fatal or serious injuries or serious damage to property.

To ensure a long and trouble free life for your opener, the following is recommended:

### Monthly

- Disengage the opener and manually operate the door: The door must be smooth to operate by hand. An operating force on the bottom rail should not exceed 150N (15kg) force.
- Each month check that the opener reverses when the door contacts a 40mm high object placed on the floor

**NOTE:** If the door does not operate smoothly, call your nearest Authorised Dealer.

### Yearly

B&D suggests that you contact your nearest Authorised Dealer to perform an annual door service.

### Service Record

Record any maintenance in the following table to assist in any warranty service.

Date	Service by	Signature	Invoice No.	Amount



**CAUTION:** Frequently examine door, particularly cables, springs and mountings for signs of wear, damage or imbalance. Do not use if repair or adjustment is needed since a fault in the installation or an incorrectly balanced door may cause injury.

Adjustments should only be carried out by experienced persons, as this function can be dangerous if not performed under strict safety procedures.



**WARNING!** Failure to maintain your garage door may void the warranty on your garage door opener.

### Warranty Expired Indicator

When the opener reaches the number of cycles covered by warranty, the courtesy light will flash 10 times after each operation. This flashing will continue for twenty (20) operations unless the user acknowledges the warranty expiry indicator and stops the light from flashing. To stop the courtesy light flashing, press the LIMIT SET button while the light is flashing after an operation.



# Troubleshooting guide

Symptom	Possible cause	Remedy
The opener does not work from the hand remote control transmitter	Garage door in poor condition e.g. springs may be broken	Check the door for normal operation – see monthly maintenance.
	Manual door lock engaged	Disengage door locks
	The opener does not have power	Plug a device e.g. a lamp, into the power point and check that it is OK.
	The battery in the remote control transmitter is flat	Replace the battery
	The transmitter code has not been set	See remote control transmitter & code setting procedure
The motor runs but the door does not move	The opener is disengaged	Re-engage the opener
The remote control transmitter range varies or is restricted	Variations are normal depending on conditions e.g. temperature or external interference	See Instructions for correct use of remote control transmitter
	The battery is flat or faulty	Replace the battery
	Position of the remote control transmitter in the motor vehicle	Change the position – see Instructions for correct use
	Position of the aerial will not pick up the radio signal	Install an external aerial kit – see Accessories Section
The light does not work	Light module is not inserted/connected properly	Check for correct connection otherwise replace module If both fail contact your dealer for support
The door reverses for no apparent reason	This may occur occasionally from weather changes	The opener automatically adjusts to compensate for changes in the door operating force
The door opens but will not close	Safety Infra-Red beam not operating correctly	Check the installation

## If You Need a Service Call

If the opener needs service please call the dealer who installed the garage door opener (for product assistance contact 1800 636 407 within Australia).

**BEFORE CALLING** you should have the following information to assist in providing the appropriate service:

1. Has anything happened since the opener last operated OK, e.g. a storm, a jolt to the door etc.?
2. How easy is it to manually open and close the door?
3. What model is the opener?
4. Who installed the opener?
5. When was it installed?

## Fault Indicator

When a fault is detected the SERVICE LED will start to flash and a number of beeps will sound to indicate that there is a fault. The fault will be active each time an attempt is made to operate the door.

Pressing the LIMIT SET button will reset the opener. If the fault continues to be tripped contact an Authorised Dealer for assistance.





# Spare Parts

ITEM NO.	DESCRIPTION	ORDER CODE
1	DRIVE CHASSIS VR1	63013
2	CLUTCH GEARED MOTOR ASSY 13 WS	60375
3	HEX SERRATION HEAD SCREW M6x16	10170
4	TRANSFORMER TDB-72-01 V2 KIT	62035
5	CORD GRIP GROMMET SB5P-2	65606
6	POWER CORD A.S 1.5M W2P+1R	14150
7	EMC FILTER BOARD EMC-2.02	61443
8	PAN HEAD SCREW W/WASHER M4x8	10320
9	WIRE EARTH ASSY 250L	12160
10	SUPPORT CHASSIS VR1	16215
11	GROMMET 101422	65603
12	TIMING ASSY	61732
13	TIMING HARNESS ASSY	61791
14	DUST COVER TOP	63223
15	TAPTITE SCREW 'P' M4x10	10570
16	RDC-1V2FM CONTROL BOARD DCB01-1.02	71273
17	TAPTITE SCREW 'P' M4x6	10582
18	LED LIGHT L T01-1.01	71232
19	LIGHT DIFFUSER VR1-2 SP	65126
20	LABEL CONTROLS VR1 V2	79110
21	LABEL LOGO VR1-2 FM	72932
22	TAPTITE SCREW 'P' M4x8	10580
23	MOUNTING BRACKET VR1	62504
24	TIMING COVER VR1	63228
25	MAIN COVER VR1 RED	16253
26	LABEL WARNING VR1-2 FM	72848
27	INDUSTRIAL SADDLE	63175
28	CONTROLS COVER SP VR1	65105
29	INTERNAL GEAR 8225-40 ASSY	16025
30	CLAMP WASHER	11180
31	RETAINING RING STW 45	10650
32	U-BOLT M8	10141
33	STRING HANDLE ASSY	61762
34	HEX SERRATION HEAD SCREW M8x16	10122
35	PAN SERRATION HEAD SCREW M4x12	10380
36	HEX SERRATION FLANGE NUT M8 (BLACK)	10148
37	FLAT WASHER 8.4x18x1.6	11021
38	ACCESSORY PACK INTERNAL GEAR VR1	61486
39	EXTENSION FORK 58L	16028
40	HEX SERRATION HEAD SCREW M6x45	10173
41	FLAT WASHER 107D 6.4x20.5x1.6	11038
42	WEIGHT BAR	71190

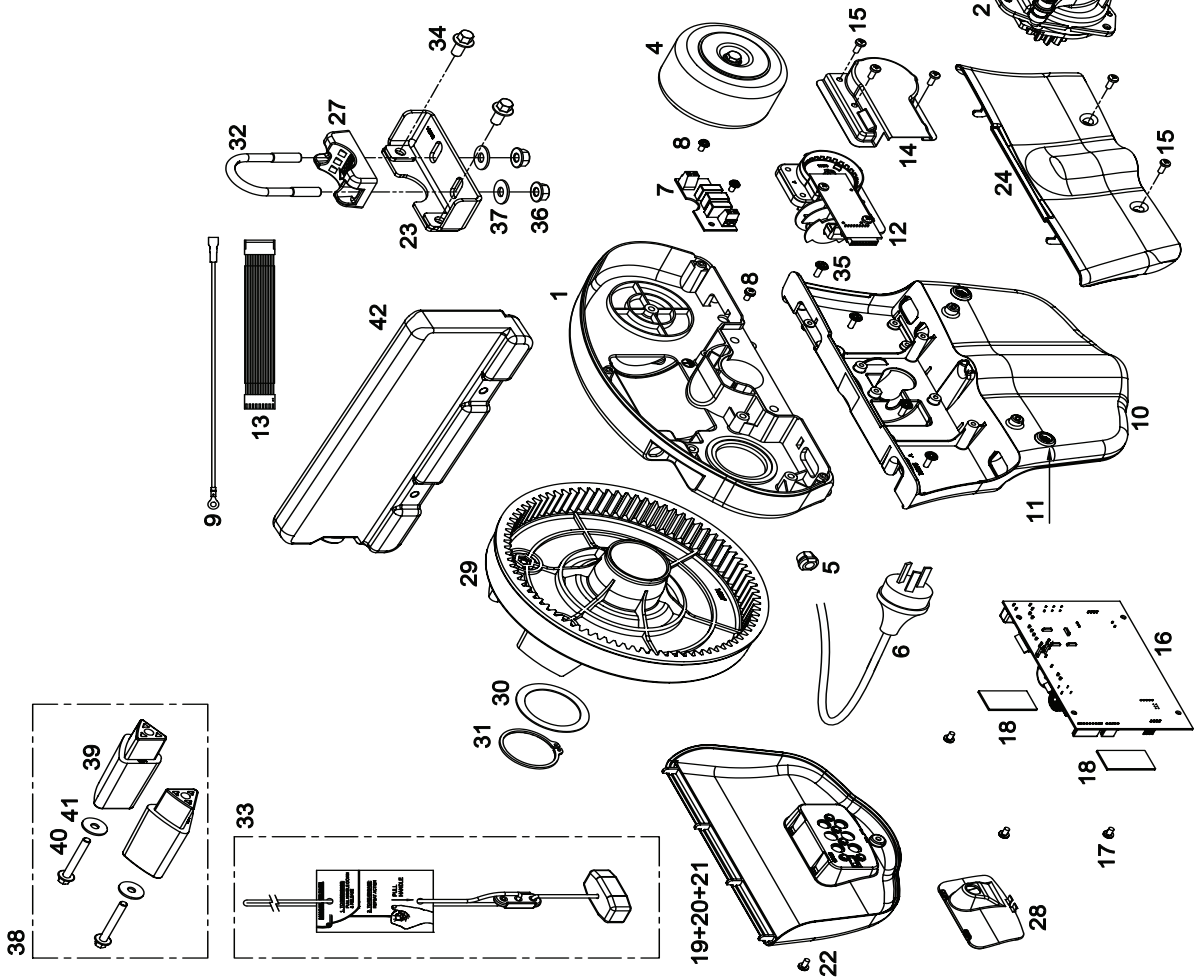

# Warranty

## 1. Definitions

### **'B&D' means**

(a) in Australia - B&D Doors of 17 Oasis Court, Clontarf, Queensland, 4019, a division of B&D Australia Pty Ltd (ABN 25 010 473 971), or

(b) in New Zealand - B&D Doors NZ Ltd of 70 Allens Road East Tamaki Auckland, which is a subsidiary of B&D Australia Pty Ltd.

**'Purchaser' means** the purchaser of the Opener.

**'Opener' means** the 'Controll-A-Door Automatic Garage Door Opener'

**'Authorised Distributor' means** an authorised B&D distributor of the Opener.

**'Major Components' means** all components of the Opener that make up the power head that is attached to a garage door.

**'Ancillary Components' means** all components of the Opener which are not Major Components.

**'Manufacturer's Written Instruction Manual' means** the instruction manual provided with the Opener.

2. This warranty applies to every sale of an Opener to a Purchaser by B&D or its Authorised Distributor, and is the only warranty given on behalf of B&D.
3. B&D warrants that it will, at its option, either repair or replace any defects:
  - (i) in materials or workmanship in the Opener, subject to the following:
    - (a) for Major Components of the Opener that are installed by B&D or an Authorised Distributor the warranty shall be valid for a period of twenty four (24) months or 5,000 cycles (whichever occurs first);
    - (b) for Major Components of the Opener that are not installed by B&D or an Authorised Distributor the warranty shall be valid for a period of twelve (12) months, provided that all costs of disconnection, reinstallation and freight shall be borne by the Purchaser. For Ancillary Components of the Opener the warranty shall be valid for a period of twelve (12) months.
  - (ii) in installation for a period of twelve (12) months from the date of installation where the Opener has been installed by B&D or its Authorised Distributor.
4. The warranties provided in clause 3(i) shall only apply to an Opener which is being used under normal use and service in accordance with the Manufacturer's Written Instruction Manual and are limited to the repair or replacement, at B&D's option, of any defective Opener or parts thereof.
5. The warranty provided in clause 3(i) shall apply from:
  - (i) the date of delivery of the Opener by B&D; or
  - (ii) the date of installation of the Opener by B&D or one of its Authorised Installers; or
  - (iii) the date of purchase of the Opener by the Purchaser;
 whichever is the latter.
6. (i) Where the Opener has been sold to the Purchaser by B&D, the Purchaser shall make all warranty claims hereunder directly with B&D;
  - (ii) Where the Opener has been sold to the Purchaser by an Authorised Distributor, the Purchaser shall make all warranty claims hereunder directly with the Authorised Distributor.
7. The Purchaser will pay for any service call made by B&D or an Authorised Distributor where such a call is made for the purpose of adjustment (as described in the Manufacturers Written Instruction Manual) and not for rectification of a defect pursuant to the warranty hereunder.
8. (i) The Purchaser shall be responsible for any expense incurred by B&D or an Authorised Distributor in ensuring that the Opener is readily accessible for any repair work carried out under this warranty. Where an Opener is installed outside a capital city metropolitan area and a warranty claim is made pursuant to this warranty, any travelling expenses and costs of transporting the Opener, incurred by B&D or its Authorised Distributor, shall be borne by the Purchaser.



# Warranty

9. Subject to paragraph 12 hereof;
- (i) the obligations of B&D under this warranty are limited to those contained herein and such warranties are expressly in lieu of all other warranties, express or implied, including any implied warranty of merchantability or fitness for a particular purpose and notwithstanding any course of dealing between the parties or custom and usage in the trade to the contrary.
  - (ii) B&D shall not be subject to nor incur and the Purchaser releases B&D from any claim or liability (including consequential loss or damage and loss or use or profit) by reason of delay, defective or faulty materials or workmanship, negligence or any act, matter or thing done, admitted or omitted by B&D.
10. Subject to Clause 12 hereof, this warranty does not extend to and B&D will be relieved of all obligations, responsibilities and liabilities (direct or consequential) in the event that defects in manufacture of the Opener are directly or indirectly in the opinion of B&D due to or result from:
- (i) being fitted to any door or other closing device which is not of the type or condition defined in the Manufacturers Written Instruction Manual as suitable for installation of the Opener.
  - (ii) Lack of proper maintenance or care – failure to have the door serviced annually may void this warranty.
  - (iii) Incorrect and unreasonable use.
  - (iv) Faulty installation or adjustment of the Opener or door to which the Opener is connected where such installation or adjustment is not carried out by B&D or one of its Authorised B&D Distributors.
  - (v) Failure to observe any instructions or directions provided with the Opener or given to the Purchaser by B&D or an Authorised Distributor.
  - (vi) Modifications or repairs made or attempted to be made by any unauthorised person.
  - (vii) Faulty electrical wiring of structures to which the Opener is affixed.
  - (viii) Radio (including citizen band transmissions) or other electronic interference.
  - (ix) Water damage, including effects from rust and corrosion.
  - (x) Use with doors locked.
11. The warranty contained in Clause 3 does not cover batteries or globes and B&D shall not be liable for any defect, malfunction or failure of such items.
12. It is expressly provided that the warranties or any terms and conditions of them or other statement contained in this document or other literature given to the Purchaser shall not be read or applied so as to purport to exclude, restrict or modify or have the effect of excluding, restricting or modifying the application in relation to the supply of the Opener of all or any of the provisions of Divisions 2 and 2A of Part V of the Trade Practices Act, 1974, or the Consumer Guarantees Act 1993 if the purchase is a 'consumer' and purchased the opener in New Zealand, ("The Act") as amended or the exercise of a right conferred by such a provision or any other condition or warranty implied by any relevant State Act or Territorial Ordinance or by the general law and which by law cannot be excluded, restricted or modified provided that to the extent that the Act permits B&D to limit its liability for a breach of condition or warranty implied by the Act, B&D's liability for such breach shall be limited to the payment of the cost of replacing the Opener or acquiring an equivalent Opener or repairing the Opener.
13. This warranty shall be governed by and construed in accordance with Australian law if the opener was purchased in Australia, or New Zealand law if the opener was purchased in New Zealand
14. Upon making a claim under this warranty the purchaser must produce proof of the date of purchase, together with the details set out below:

Purchased From: _____ Installed By: _____ Installed Date: _____
---

The Purchaser shall complete this certificate and keep it together with a copy of the receipt of purchase in a safe place – production of such information will assist the handling of a claim made under this warranty.

QLD Office: 17 Oasis Court, Clontarf 4019. Ph: (07) 3883 0200  
NSW Office: 34-36 Marigold St, Revesby 2212. Ph: (02) 9722 5555  
VIC/TAS Office: 147-153 Canterbury Road, Kilsyth 3137. Ph: (03) 9237 7766  
SA Office: 23 Frederick Road, Royal Park 5014. Ph: (08) 8440 4747  
WA Office: 96 Mulgool Drive, Malaga 6062. Ph: (08) 9247 8777  
NZ Office: 30c Allens Road, East Tamaki, Auckland. Ph: (09) 273 8600  
**www.bnd.co.nz**

B&D Doors is a Division of B&D Australia Pty Limited - ABN 25 010 473 971

©Copyright August 2009 B&D Doors. All Rights Reserved. Firmamatic™, TRI-TRAN™ are registered trademarks of B&D Australia Pty Ltd. In an ongoing commitment to product quality B&D Doors reserve the right to change specifications without notice. E&OE.

