

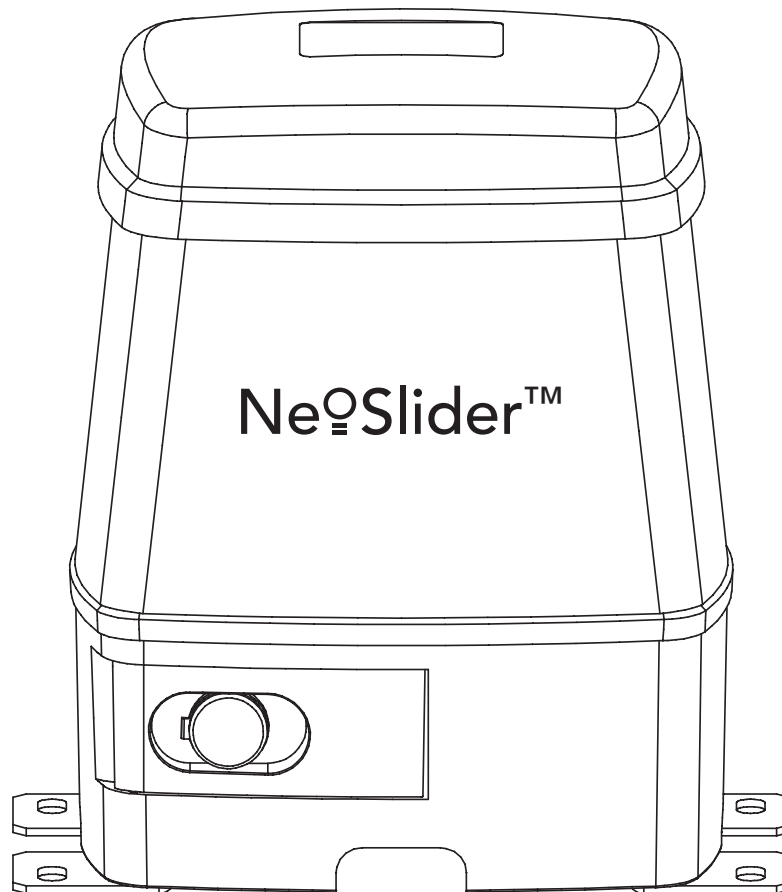

# NES-24V2 NeoSlider™

Sliding Gate Opener



Featuring **TrioCode™ 128** Technology

automatic  
TECHNOLOGY



# Important Safety Instructions

The safety alert symbols below indicate a personal safety or property damage instruction exists. **READ THESE INSTRUCTIONS CAREFULLY.** This NeoSlider™ NES-24V2 Sliding Gate Opener is designed and tested to offer safe service provided it is installed and operated in strict accordance with the following safety rules. Failure to comply with the following instructions may result in death, serious personal injury or property damage.



## WARNING!

- The gate may operate unexpectedly, therefore do not allow anything to stay in the path of the gate.
- Do not disengage the gate opener to manual operation with children/persons or any objects including motor vehicles within the gateway.
- Remove or disengage all gate locks and mechanisms prior to installation of the opener.
- Make sure the gate is fully open before driving into or out of the driveway.
- When using auto close mode, a **Photo Electric beam** must be fitted correctly and tested for operation at regular intervals. **Extreme caution** is recommended when using auto close mode. **All safety rules** must be followed.



## ELECTROCUTION!

- Do not immerse in or spray the NeoSlider with water .
- **Disconnect the power cord** from mains power before making any repairs or removing covers. Only **experienced** service personnel should remove covers from the gate opener.
- If the power supply cord is damaged, it **must** be replaced by an Automatic Technology service agent or suitably qualified person.
- Connect the gate opener to a properly **earthed** general purpose 240V mains power outlet installed by a qualified electrical contractor.



## CAUTION:

Entrapment from operating gate

- **DO NOT** operate the gate opener unless the gate is in full view and free from objects such as cars and children/people. Make sure that the gate has finished moving before entering or leaving the driveway.
- Do not allow children to play with gate controls or transmitters.
- In order for the NeoSlider™ to **sense** an object obstructing the gateway, some **force** must be exerted on the object. As a result the object, gate and/or person may suffer **damage** or **injury**.
- Regularly check to make sure that the **Safety Obstruction Force** is working correctly, and is **tested** and set as per **Section 12 of this manual**. Failure to follow these instructions could result in **serious personal injury** and/or property damage. This test must be repeated at regular intervals and the necessary adjustments made as required.
- If using a key switch, keypad or any device that can operate the gate opener, make sure it is in a location where the gateway is visible, but out of the reach of children at a height of at least 1.5m.
- For **ADDITIONAL SAFETY** protection we **STRONGLY** recommend the fitting of a Photo Electric (Safety) Beam. In most countries Safety Beams are mandatory on all gates fitted with automatic openers.
- Ensure the gate(s) is in good working order . Faulty gates must be repaired by a qualified technician prior to NeoSlider™ installation.
- Make sure that the gate is fully closed before leaving the driveway.
- Keep hands and loose clothing clear of gate at all times
- Keep clear of gate during operation as severe lacerations can occur on sharp edges of gate.

Installation

Security

Entanglement in or laceration from moving gate



# NeoSlider™

## Sliding Gate Opener NES-24V2

### Contents

|   |           |  |           |
|---|-----------|--|-----------|
| <b>1. Features</b>                                    | <b>4</b>  | <b>10. Coding Transmitter</b>                  | <b>15</b> |
| <b>2. Control Board Layout</b>                        | <b>6</b>  | 10.1 Coding Transmitter Button                 | 15        |
| <b>3. Set Up Requirements</b>                         | <b>7</b>  | 10.2 Selecting Function Of The Button          | 15        |
| 3.1 Kit Contents                                      | 7         | 10.3 Returning To Main Screen                  | 15        |
| 3.2 Choosing your Set up                              | 7         | <b>11. Remotely Coding Transmitters</b>        | <b>16</b> |
| <b>4. Drive Unit Installation</b>                     | <b>8</b>  | 11.1 Selecting The Function To Be Coded        | 16        |
| 4.1 Initial Checking                                  | 8         | 11.2 Activate Remote Code Set Mode             | 16        |
| 4.2 Mounting the Drive Unit                           | 8         | 11.3 Removing the Battery From the Transmitter | 16        |
| 4.3 Installing antenna                                | 8         | <b>12. Setting Pedestrian Position</b>         | <b>17</b> |
| <b>5. Rack &amp; Limit Actuator Installation</b>      | <b>9</b>  | 12.3 Pedestrian Position Set                   | 17        |
| 5.1 Mounting rack to gate                             | 9         | 12.4 Error Displays                            | 17        |
| 5.2 Fixing limit actuator to rack                     | 9         | <b>13. Auto-Close Mode</b>                     | <b>18</b> |
| <b>6. Wired Safety Beams Installation</b>             | <b>10</b> | 13.1 Setting Up Standard Auto-Close            | 18        |
| 6.1 Fitting the Safety Beam                           | 10        | 13.2 Safety Beam Triggered Auto Close          | 18        |
| 6.2 (2 WIRE) Safety Beam - PE3V1                      | 10        | 13.3 Pedestrian Auto-Close                     | 18        |
| 6.3 (3 WIRE) Safety Beam - PE-2 & PE-2000             | 11        | 13.4 Auto-Close After Obstruction:             | 18        |
| 6.4 Alignment   | 11        | <b>14. Accessories Installation</b>            | <b>19</b> |
| 6.5 Safety Beam Failure Emergency Close (SBFEC)       | 11        | 14.1 Fitting Solenoid Or Magnetic Locks        | 19        |
| <b>7. Programming The NeoSlider™</b>                  | <b>12</b> | 14.2 Fitting Courtesy Lights                   | 19        |
| 7.1 Common Programs                                   | 12        | <b>15. Specifications</b>                      | <b>20</b> |
| 7.2 Powering up the NeoSlider™                        | 12        | <b>16. Troubleshooting</b>                     | <b>21</b> |
| <b>8. Setting Limits</b>                              | <b>13</b> | <b>17. Appendix</b>                            | <b>22</b> |
| 8.1 Setting Travel Limits                             | 13        | A - Console Menu Structure                     | 22        |
| 8.2 Setting the left/right installation side settings | 13        | B - Viewing and Editing Parameters             | 25        |
| 8.3 Setting close travel limit                        | 13        | C - Control Board Adjustments                  | 26        |
| 8.4 Setting open travel limit                         | 13        | D- Diagnostic Tools                            | 28        |
| 8.5 Automatic limit adjustment and load profile       | 13        | E - Memory Tools                               | 29        |
| 8.6 Pedestrian access position                        | 13        | F- Transmitter Editing                         | 30        |
| 8.7 Errors during setting of travel limit             | 13        | G- Transmitter Management                      | 31        |
| <b>9. Safety Obstruction Force Test</b>               | <b>14</b> | <b>18. Warranty and Exclusion of Liability</b> | <b>32</b> |
| 9.1 Testing Close Cycle                               | 14        |  |           |
| 9.2 Testing Open Cycle                                | 14        |  |           |
| 9.3 Force Pressure For Close and Open Cycle.          | 14        |  |           |
| 9.4 Reprofileing Travel                               | 14        |  |           |

Automatic Technology Australia Pty Ltd to the extent that such may be lawfully excluded hereby expressly disclaims all conditions or warranties, statutory or otherwise which may be implied by laws as conditions or warranties of purchase of an Automatic Technology Australia Pty Ltd Garage Door Opener. Automatic Technology Australia Pty Ltd hereby further expressly excludes all or any liability for any injury, damage, cost, expense or claim whatsoever suffered by any person as a result whether directly or indirectly from failure to install the Automatic Technology Australia Pty Ltd Garage Door Opener in accordance with these installation instructions.

# 1. Features

Thank you for purchasing the NES-24V2 NeoSlider™ from Automatic Technology. Designed for residential sliding gates by our world renowned team of engineers, this unit will give years of smart, simple and secure operation. Listed below are some of the many features.

## Operation

To activate the gate simply press a button on the TrioCode™128 transmitter, keypad or other optional control devices. During an open or close cycle, the gate can be stopped by pressing the button whilst it is in motion. The next actuation will move the gate in the opposite direction.

## Operator Console

The NeoSlider™ features a LCD display operator console which simplifies installation, adjustments and status indication. Features include editing transmitter storage and names, setting parameters, selecting specialised operating modes and performing system diagnostics.

## TrioCode™128 Technology

Only transmitters with the TrioCode™128 Technology can operate with the latest Openers, reducing the chance of interference from other radio frequency sources. Every time a TrioCode™128 transmitter is used a new security code is randomly generated from over 100 billion possibilities. This greatly enhances the security of the system and makes "code grabbing" a thing of the past. TrioCode™128 transmitters have the ability to code into earlier model openers.

## Security Code Store

The NeoSlider™ Sliding Gate Opener uses revolutionary technology to securely store up to thirty (30) transmitters in its memory with the ability to assign an 11 character name to each.

## Installation

The display console on the NeoSlider™ "holds your hand" through the installation and setup process. Also, during installation a handheld transmitter can be used to set gate travel limits, allowing the installer to closely monitor the gate's position and stop points instead of having to be within arms reach of the console.

## Iss (Intelligent Safety System)

Should the gate hit an obstacle while it is performing a close cycle, or be restricted in some manner, it will automatically reverse. The amount of force the gate should encounter before reversing is automatically adjusted by the control system during the initialisation of the automatic opener. The gate will also stop if restricted whilst opening. The Safety Obstruction Force should be checked at least once a month. See installation manual for instructions.

### Status Indicator

The LCD console display screen indicates through text the status of the NeoSlider™. When the MAIN SCREEN is displayed, the current position of the gate or the result of the last movement can be viewed. The display also shows the countdown timer for Auto-Close operations. Any active input will also be displayed along with the state of various features such as periodic service, battery backup operation and vacation mode.

### Control of Lock and Lights

The incorporated controller has dedicated outputs for operating an electric lock and warning or courtesy lights. The timing of these outputs can be adjusted to suit your needs. In addition a button on a remote transmitter can be coded to operate the light output.

### Extensive Operating Modes Via Control Inputs And Remote Control

The integrated controller can be configured to operate in many different ways via the seven (7) control and safety inputs which include SB, OPEN, STOP, CLOSE, OSC, SWIPE and PEDESTRIAN.

Operation is provided with each transmitter's button being able to be configured to operate one of OSC, PEDESTRIAN, SWIPE, CLOSE, OPEN, STOP, LIGHT or VACATION functions.

The functionality of the transmitter is further enhanced by four (4) Auto-Close modes, three (3) PE Beam response modes and two (2) pedestrian response modes.

### SmartSolar™ and Battery Backup Compatibility (optional)

The gate opener can be fitted with a SmartSolar™ or Battery Backup kit for operation in the event of a power outage, or where mains power access is not available.

### Manual Operation

The gate opener is equipped with a unique manual disengaging device. If the power to the gate opener is disrupted for any reason, the gate can be disengaged via a keylock located on the operator, allowing you to manually open or close the gate.

# 2. Control Board Layout

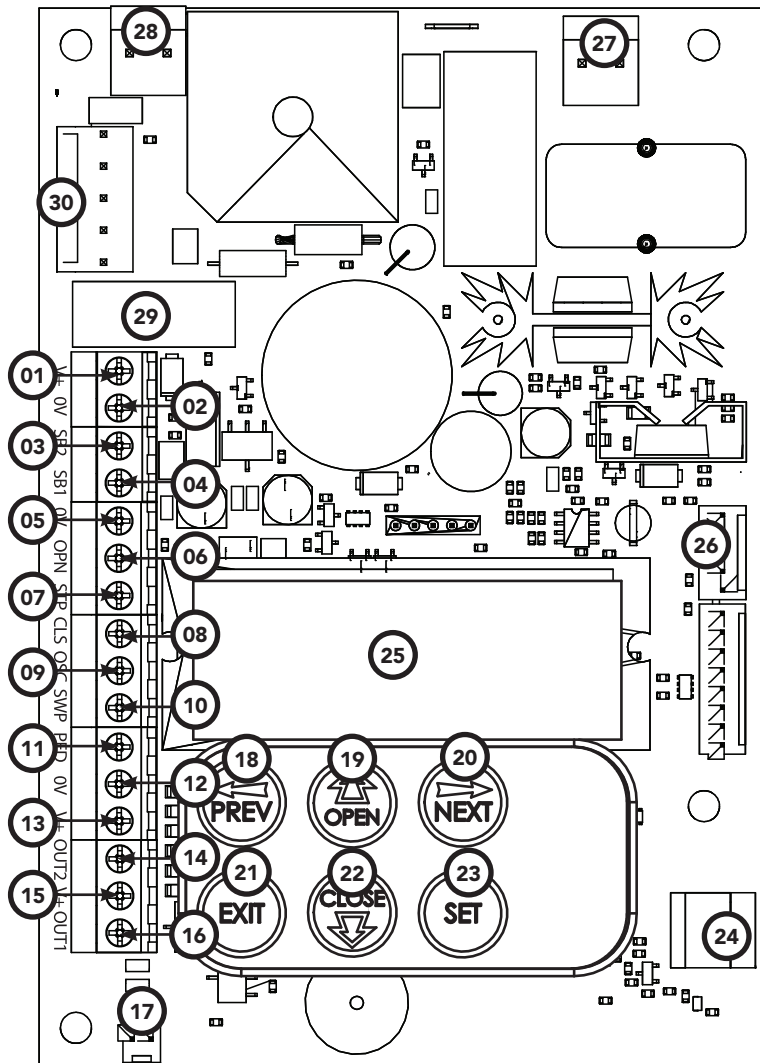

Fig 2.1

- |  |   |  |
|--|---|--|
| 01 V+  | 11 PED N/O input terminal                   | 21 Console Exit button                     |
| 02 0V  | 12 0V                                       | 22 Console Down/Close button               |
| 03 SB2 (Safety Beam(2), two, three wire or wireless) | 13 V+                                       | 23 Console SET button                      |
| 04 SB1 (Safety Beam(1), two, three wire or wireless) | 14 OUT 2 (optional relay module coil drive) | 24 Antenna connector                       |
| 05 0V  | 15 V+                                       | 25 Console display                         |
| 06 OPN Programmable N/O or N/C input terminal        | 16 OUT 1 N/C relay contact                  | 26 PG3 programmer connector                |
| 07 STP Programmable N/O or N/C input terminal        | 17 Engage sensor microswitch input          | 27 Motor connector                         |
| 08 CLS N/O input terminal                            | 18 Console Previous button                  | 28 24VAC input connector                   |
| 09 OSC N/O input terminal                            | 19 Console Up/Open button                   | 29 10 AMP slow blow fuse                   |
| 10 SWP N/O input terminal                            | 20 Console Next button                      | 30 Standby battery charger/solar connector |

# 3. Set Up Requirements

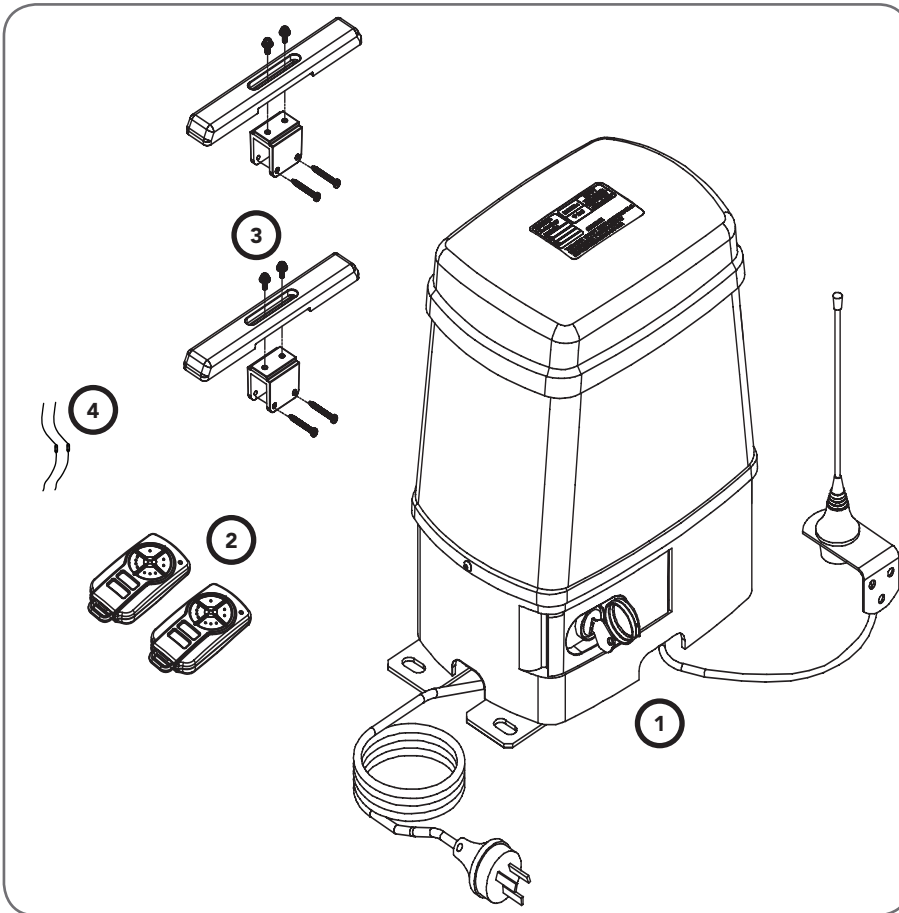

Fig 3.1

## 3.1 Kit Contents

| ITEM | DESCRIPTION                      | QTY | ORDER CODE |
|------|----------------------------------|-----|------------|
| 1    | DRIVE UNIT NES-24V2              | 1   | 60109      |
| 2    | TRIO-CODE 4B PTX-5V2 TRANSMITTER | 2   | 61160      |
| 3    | ACCESSORY ACTUATOR PACK          | 2   | 61463      |
| 4    | RESISTOR 5K6                     | 2   | 65882      |

**! IMPORTANT WARNING!**  
 A qualified electrician must perform the installation where 240V AC power is used.

## 3.2 Choosing your Set up

The NeoSlider™ can be set up in various ways and therefore may require additional items. Common Set ups are as follows;

| Set Up                             | Items Required                                      |
|------------------------------------|---|
| Automated Set Up                   | Drive Unit and transmitter                          |
| Automated Set Up with Safety Beams | Drive Unit, transmitter and safety beams (optional) |

**! CAUTION:** Cables which have a green/yellow coloured insulation are for earthing purposes only. Never use these cables for any other purpose.

# 4. Drive Unit Installation



## IMPORTANT SAFETY INSTRUCTIONS FOR INSTALLATION

**Warning: Incorrect installation can lead to severe injury.  
Follow ALL installation instructions.**

The Automatic Technology NeoSlider™ sliding gate opener is designed to operate most residential sliding gates. The gates must be in good working condition and should operate freely by hand.

### 4.1 Initial Checking

Before commencing installation of the NeoSlider™, check the following:

- The gate moves freely and easily by hand for the full opening and closing travel.
- The mounting point must be solidly constructed, e.g concrete, brick or steel, and must be capable of withstanding the full force applied to the gate.
- Select a suitable location for mounting the drive unit. This position is usually established by fully opening the gate and mounting the drive unit within a suitable distance of the gate edge.
- A weather-proof 240v 10 amp power outlet must be located within one (1) metre of the NeoSlider™ mounting point.
- If Safety Beams are to be installed, provision for underground cabling should be made from one side of the gateway to the other.

### 4.2 Mounting the Drive Unit

The NeoSlider™ mounting holes are slotted for fine adjustment of pinion gear and gate rack alignment. Follow the procedure below to ensure final adjustments can be made later.

We recommend that four 8mm ( $\frac{5}{16}$ " ) or 10mm ( $\frac{3}{8}$ " ) loxins and bolts are used to secure the Drive Unit into position. These loxins usually require a 16mm ( $\frac{5}{8}$ " ) masonry drill bit (if drilling concrete).

- Prior to mounting the NeoSlider™, determine the distance from the gate to the outer edge of the rack (i.e. the rack width) and to the datum line (see Fig. 4.2 and Fig. 5.1). If using an Automatic Technology plastic rack, the width is 40mm. If using a different brand of rack, please ensure it is Module 4 and then confirm the width, as this will vary.
- Mark a line parallel to the face of the gate for the mounting holes. The distance from the gate is determined by the formula (38mm + Rack Width). Therefore, if using an Automatic Technology rack, the distance is 78mm. Otherwise, if using a non-Automatic Technology rack, add your rack width (and spacers if required) to the 38mm (see Fig. 4.2).
- Another 100mm back, mark another line parallel to that described in point 2 for fixing. (see Fig. 4.2).
- Open the gate to the desired open position. Mark a line at a right angle to the gate 120-150mm from the open edge of the gate for the mounting holes.
- Then mark another line 268mm parallel to this line (see Fig. 4.2).
- Place the Drive Unit in position where the lines intersect to check the mounting position. If satisfied with the position, remove the Drive Unit.
- Drill the four mounting holes where the lines intersect.
- Hammer the loxins into position, place the NeoSlider™ and fix with the four bolts. Remember when tightening the bolts to allow fine adjustment of the NeoSlider™ later on.

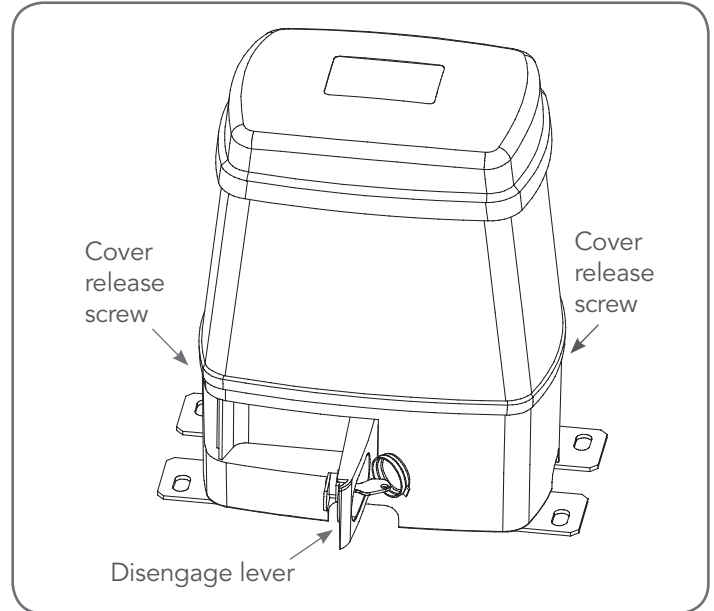

Fig 4.1

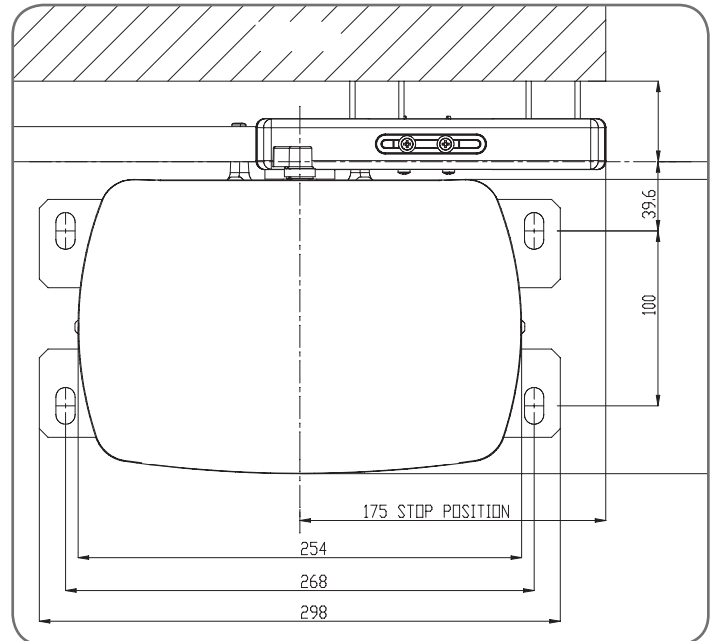

Fig 4.2

### 4.3 Installing antenna

Mount the antenna at or above the height of the gate or fence (whichever is higher) for optimal reception. Do not cut the coaxial cable.



# 5. Rack & Limit Actuator Installation

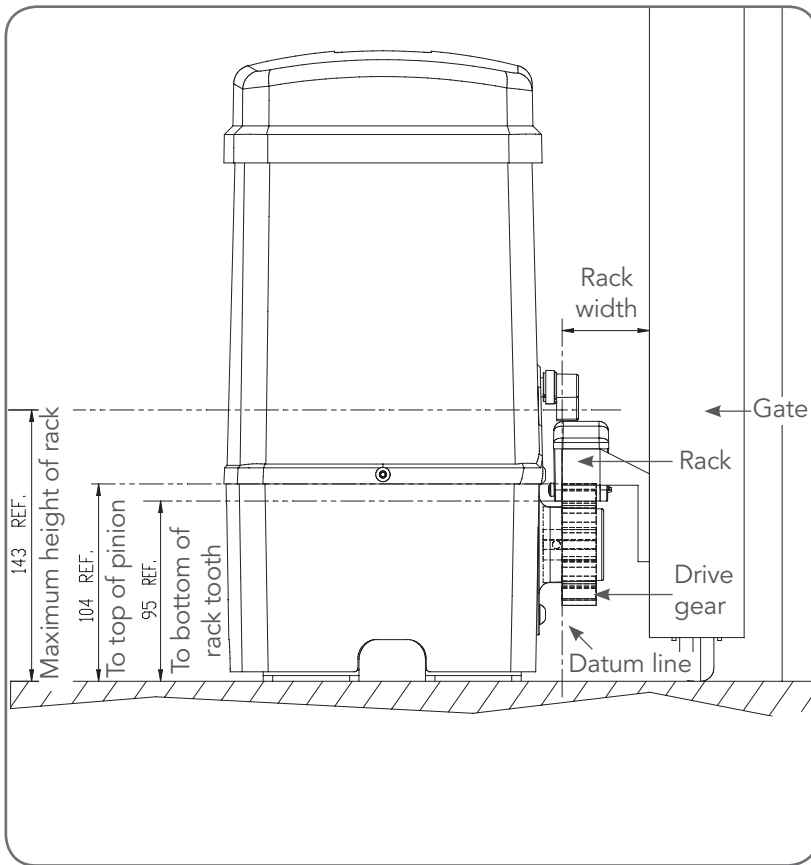

**Fig 5.1**

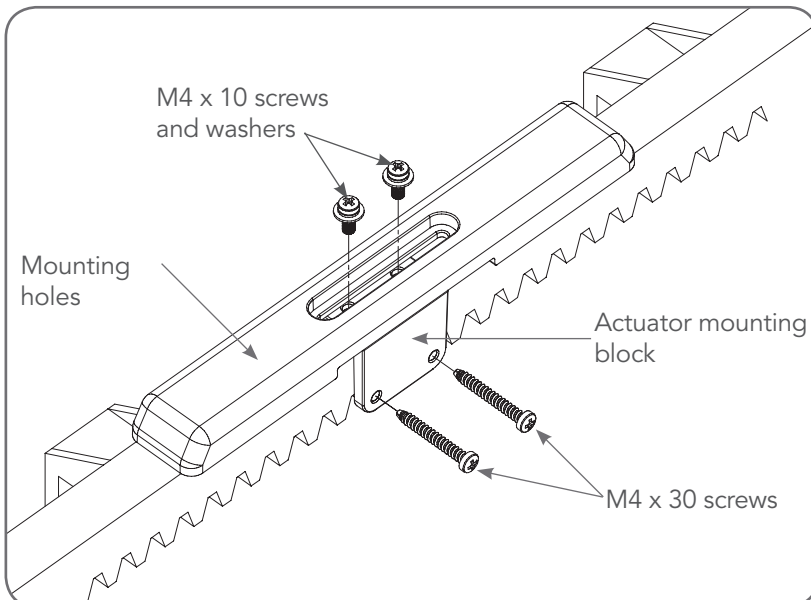
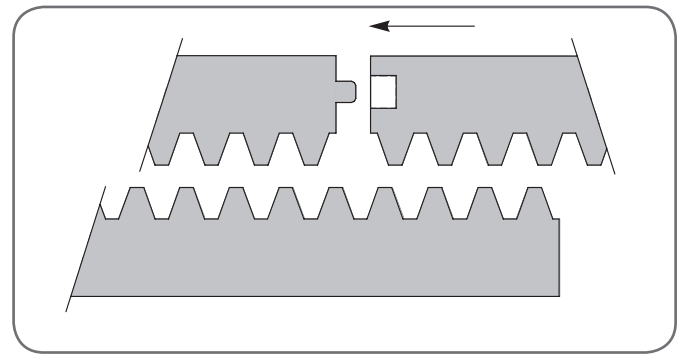

**Fig 5.3**

## 5.1 Mounting rack to gate

A strong base on the gate is required for mounting the rack.

- Manually open the gate and place a rack section to mesh with the pinion gear on the Drive Unit. Mark the top of the rack. Move the gate and mark the rack for the entire length of the gate.
- Position the top edge of the rack on this line and mark the centres of the rack's mounting slots. The first section of rack should start 20mm from the edge of the gate.
- Drill and tap for 6mm (1/4") screws.
- Once the first section of the rack is mounted, check that it meshes with the NeoSlider™ pinion gear.
- When joining subsequent sections of rack, check the mesh by placing a spare section upside down (teeth facing upwards) and putting it into mesh with the racks being joined (Fig. 05).
- Tighten the racks. This will ensure that the NeoSlider™ pinion can run along the racks without obstruction.



**Fig 5.2**

## 5.2 Fixing limit actuator to rack

- Manually open the gate to the open position and mark this on the gate rack under the actuating arm.
- Manually close the gate to the closed position and mark this on the gate rack under the actuating arm.
- Place start of limit actuator at marked position and move it 5 to 10mm towards the centre of the gate. Align the face of the limit actuator with the side of the rack and screw the limit actuator to the rack (Fig. 06).
- Re-check limit positions by manually opening and closing the gate, checking to see that the limit is activated at the desired open and close position. If necessary, make adjustments by sliding the actuator in the required direction. When the final settings are established, tighten the limit actuator screws - each actuator must be secured with two (2) screws.

# 6. Wired Safety Beams Installation

## Safety Beams

Safety Beams extend across the gateway opening. The Safety Beam is designed to detect an obstruction while the gate is closing and to send a signal to the gate opener to reverse or stop the gate movement. One, or two sets of Safety Beams can be connected.

The NeoSlider™ has two inputs for the Safety Beams. Both can be two or three wire Safety Beams or a combination (one 2 wire, one 3 wire).

### 6.1 Fitting the Safety Beam

- Attach the mounting bracket (4) to the adjustment bracket (3) with the pan head screw (6). (Fig. 6.1)
- Attach the bracket (2) to the Safety Beam transmitter with four tapite screws (m3x5) (7) and attach the other side to the adjustment bracket (3) with the pan head screw (6). (Fig. 6.2)
- Repeat steps a and b to assemble the Safety Beam receiver.



**CAUTION:** Locate the Safety Beam in a strategic location in the gateway. Automatic Technology recommend that the sensor is placed 100mm above the floor level and as close as possible to the gate opening.

### 6.2 (2 WIRE) Safety Beam - PE3V1

- Connect the wires from the Safety Beams wiring harness to terminal block.
  - By default the NeoSlider™ will take two wire safety beams (connect one wire to SB1 input and the second wire to 0V, next to the SB1 terminal (Fig. 6.3)).
  - For dual Safety Beams (connect one wire to SB1 input and the second wire to 0V, next to the SB1 terminal for the first safety beam, then connect one wire to SB2 input and the second wire to 0V, next to the SB2 terminal (Fig. 6.4))
- Ensure you program the NeoSlider™ to identify what type of Safety Beam or combination of Safety Beams you have installed.
  - Press NEXT to Navigate to Menu 7
  - Press SET to display Menu 7.1 (for SB1).
  - Ensure the Safety Beam type is set to two wires.
  - Press SET to accept the selection.
  - Repeat the same process for Menu 7.2 (SB2) if installed.

**NOTE:** For Wireless Safety Beam installations refer to the instructions provided with the kit. Wireless Safety Beam functionality is equivalent to 2 WIRE Safety Beams

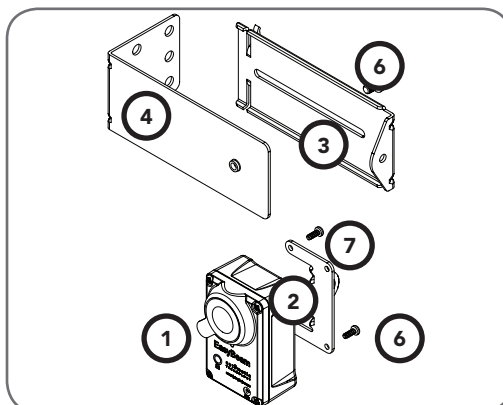

Fig 6.1

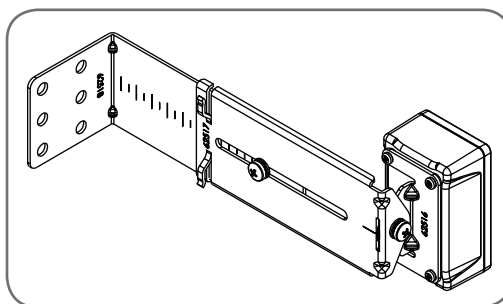

Fig 6.2



**WARNING:** When using Safety Beams, the gateway must be clear of all obstructions and persons at all times. The location of the beams and manner in which it is installed might not give safety protection at all times. Check to make sure that the height of the beam and type used give maximum protection possible



**WARNING:** Tampering with Safety Beams could result in serious personal injury and/or property damage and will void the warranty.

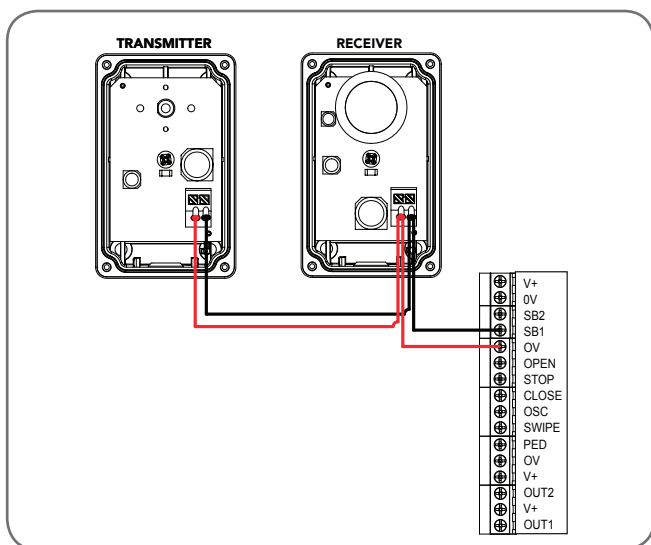

Fig 6.3

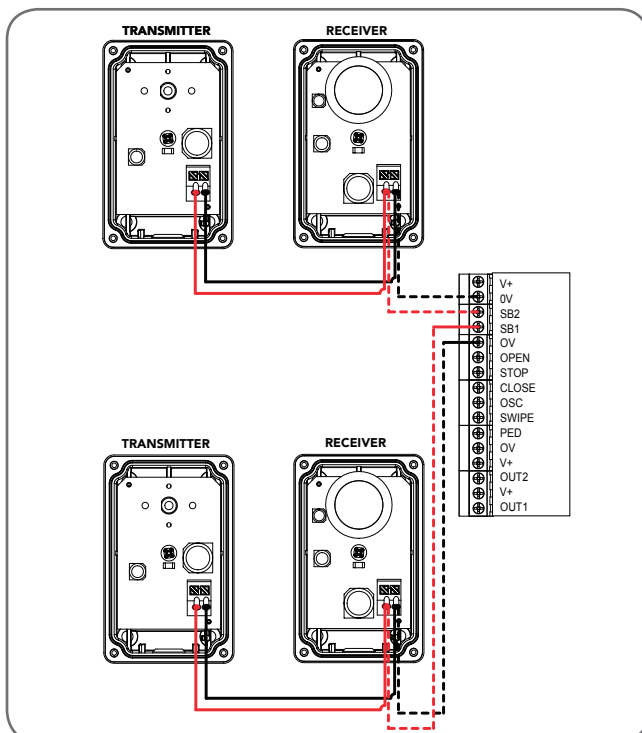

Fig 6.4

# 6. Wired Safety Beams Installation

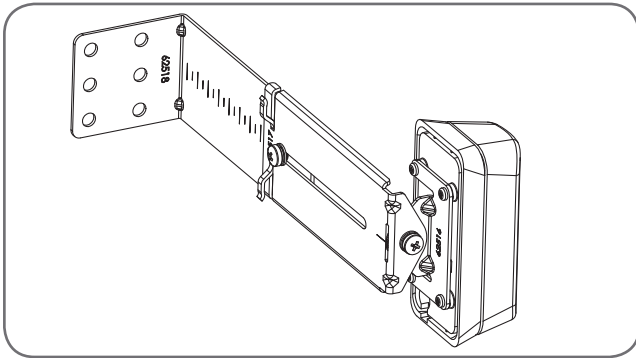

Fig 6.5

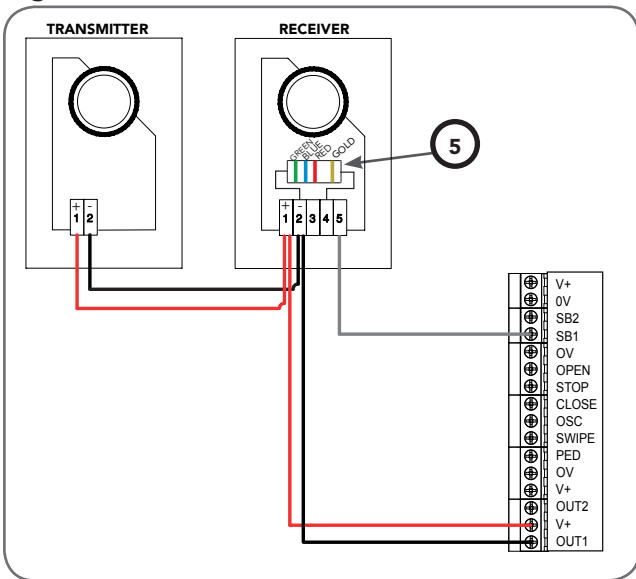

Fig 6.6

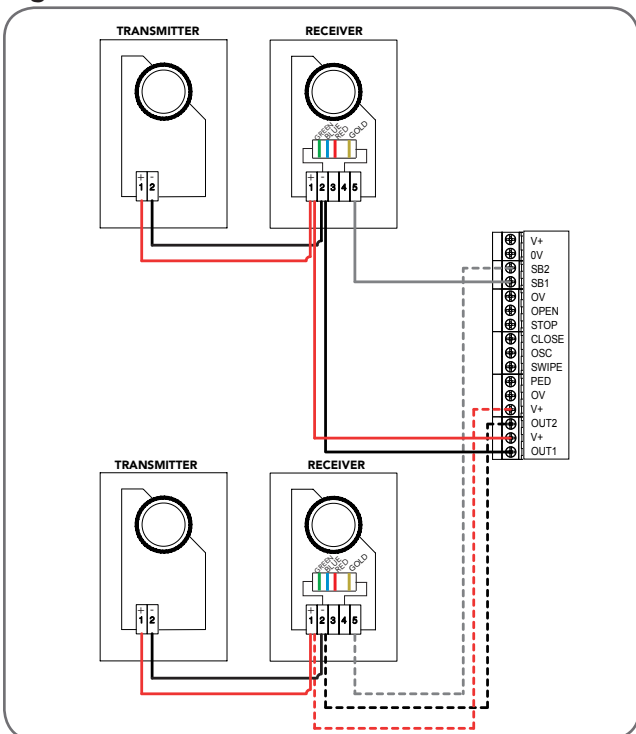

Fig 6.7

## 6.3 (3 WIRE) Safety Beam - PE-2 & PE-2000

Using three wire with power saving mode (turns off power to the safety beam when opener is not in use). Assemble the Safety Beam as per Section 6.1 to look like (Fig 6.5).

- a. Connect the Resistor 5k6 ohms (Green Blue Red Gold) ⑤ to number 2 (two) and 4 (four) terminal on the Safety-2 receiver (Fig. 6.6).
  - i. For single Safety Beams, connect the yellow wire to SB1 input and the red wire to V+, next to the OUT1 common terminal and the black wire to the OUT1 common terminal.
  - ii. For dual Safety Beams, connect the yellow wire to SB1 input and the red wire to V+, next to the OUT1 common terminal and the black wire to the OUT1 common terminal for the first safety beam. For the second safety beam, connect the yellow wire to the SB2 input and the red wire to the V+, next to the OUT2 common terminal and the black wire to the OUT2 common terminal. (Fig. 6.7)
- b. Ensure you program the NeoSlider™ to identify what type of Safety Beam or combination of Safety Beams you have installed.
  - i. Press NEXT to Navigate to Menu 7
  - ii. Press SET to display Menu 7.1 (for SB1).
  - iii. Use the UP and DOWN arrows to change the Safety Beam type from two to three wires.
  - iv. Press SET to accept the selection.
  - v. Repeat the same process for Menu 7.2 (SB2) if installed.

**NOTE:** The Power control for one or both three wire beams is controlled via OUT 1 or OUT 2. To use the OUT 1, connect black wire from SB to OUT 1. To enable power control from OUT 1, go to Menu 7.13 and change OUT1 mode to 3 wire SB 0V.

**NOTE:** In the case that OUT 1 is used for some other function, OUT 2 can be used to control 3 wire beams power. Connect the black wire from SB to OUT 2, then change the OUT 2 mode in Menu 7.14 to 3 wire SB 0V.



**WARNING:** When using Safety Beams, the gateway must be clear of all obstructions and persons at all times. The location of the beams and manner in which it is installed might not give safety protection at all times. Check to make sure that the height of the beam and type used give maximum protection possible



**WARNING:** Tampering with Safety Beams could result in serious personal injury and/or property damage and will void the warranty.

## 6.4 Alignment

- a. Power up the NeoSlider™ with the Safety Beam connected. The green LED on the transmitter should turn ON to indicate power is present.
- b. If the receiver is connected to power and the red LED is flashing while the green LED on the transmitter is on, the transmitter and receiver are not aligned.
- c. Make horizontal and/or vertical adjustment on the transmitter and/or receiver until the red LED on the receiver turns on, indicating alignment.

## 6.5 Safety Beam Failure Emergency Close (SBFEC)

When the user finds that they are unable to move the gate and suspect that it is due to a faulty SAFETY BEAM they can attempt to enter Safety Beam Failure Emergency Close mode by pressing and holding a pre-coded button on the remote control or OPEN/CLOSE button on the console for more than five seconds. the gate will start closing. See Appendix C Menu 7.16.



# 7. Programming The NeoSlider™

## 7.1 Common Programs

The two most common programs are;

| Program                            | Menu's required | Function                 | Section             |
|------------------------------------|-----------------|--------------------------|---------------------|
| Automated Set Up                   | Menu 10.1       | Setting the Limits       | 8.1                 |
|                                    |                 | Safety Obstruction Force | 9.1 and 9.2         |
|                                    | Menu 1          | Coding the Transmitter   | 10.1                |
| Automated Set Up with Safety Beams | Menu 10.1       | Setting the Limits       | 8.1                 |
|                                    |                 | Safety Obstruction Force | 9.1 and 9.2         |
|                                    | Menu 1          | Coding the Transmitter   | 10.1                |
|                                    | Menu 3          | Auto Close Times         | 13.2, 13.3 and 13.4 |

Fig 7.1

**NOTE:** Fitting Safety Beams enables the Auto-Close feature to become active.



**CAUTION:** Before plugging the gate control system in, check the power cord for damage and ensure it cannot become entangled in any moving parts

## 7.2 Powering up the NeoSlider™

- After checking the initial wiring, apply power to the NeoSlider™. The controller will go through a startup sequence displaying the STARTUP SCREEN which indicates the controller type and firmware version (**Fig. 7.2**). After a short delay the MAIN SCREEN will be displayed.
- If this is the first time the NeoSlider™ has been used, the MAIN SCREEN should indicate that the limits are not set (**Fig. 7.3**). If the display shows that some input is active then rectify the situation before proceeding. If a default setting is to be changed it should be done now before setting the travel limits.

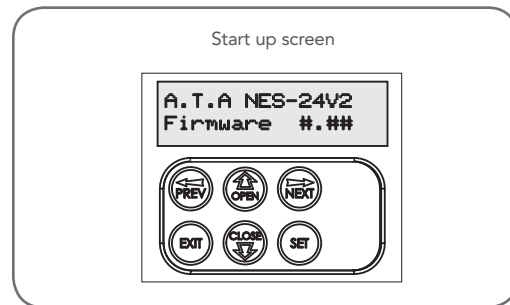

Fig 7.2

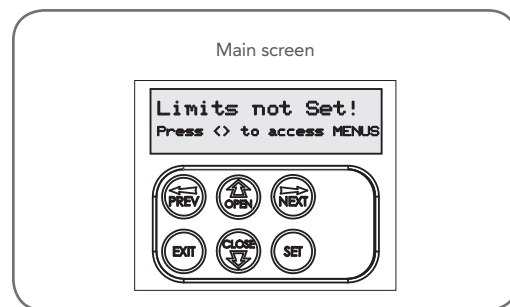

Fig 7.3

# 8. Setting Limits

The NeoSlider™ has the alternate ability to set travel limits using a TrioCode™128 transmitter, allowing free movement around the gate to better assess the desired limit positions. In order to use a transmitter, it must first have at least one of its buttons coded to the gate controller. The function assigned to the transmitter's buttons is of no concern here as the buttons are temporally assigned to OPEN, CLOSE and SET (Fig. 8.1).

**NOTE:** Gate should be moved manually to fully open position. When re-engaging opener, nudge gate until click is heard to confirm pinion gear has engaged fully.

## 8.1 Setting Travel Limits

Navigating to "code transmitter" menu

1. Press NEXT to navigate to Menu 1.
2. Press SET to enter the code set procedure (Fig. 8.2).

### Storing Transmitter Code

- a. Controller will prompt to press one of the transmitter's Button.
- b. Press the transmitter button you wish to use to operate the gate opener (e.g. button 1).
3. Press the same transmitter button again as prompted by display.
4. Press the SET button to store the transmitter.

### Navigating To "Set Gate Travel Menu"

- a. Press PREV to navigate to Menu 10.
- b. Press SET to display MENU 10.1.
- c. Press SET two times to enter the limit setting procedure. Follow LCD prompts.

## 8.2 Setting the left/right installation side settings

- a. Select left or right installation side by pressing open button for the correct side (Fig. 8.2).
- b. Press SET to confirm.

## 8.3 Setting close travel limit

- a. Press and hold Button 4 on the transmitter to close the gate
  - i. If the gate is closed too far, press Button 1 to "inch" the gate towards open.
  - ii. When happy with the close limit position, press Button 2 to store this in the memory.

**NOTE:** Limit will not be accepted unless the gate is driven in the close direction.

## 8.4 Setting open travel limit

- a. Press Button 1 to open the gate.
- b. If the gate is opened too far, press Button 4 to "inch" the gate towards close
- c. When happy with the open limit position, press Button 2 on the transmitter to store into memory..

**NOTE:** Limit will not be accepted unless the gate is driven in the open direction.

**WARNING:** The gate will automatically close and open once next step is performed. Ensure that no persons or objects are in the gates path

- d. The gate will now automatically close and open to calculate the safety obstruction settings.

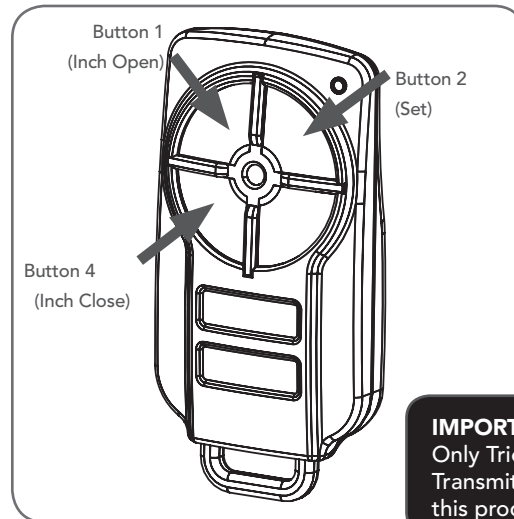

Fig 8.1

**IMPORTANT NOTE:**  
Only TrioCode™128 Technology Transmitters are compatible with this product.

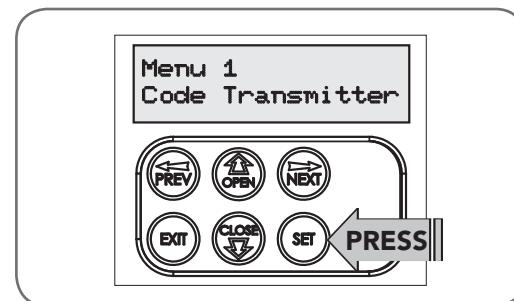

Fig 8.2

## 8.5 Automatic limit adjustment and load profile

After a brief pause, the controller will automatically close and open the gate several times. This adjusts the speed at which the limits are approached and helps to learn the normal load profile of the gate. When the setup is complete, the MAIN SCREEN will be displayed with the gate shown to be OPEN. The Gate can now be used.

**NOTE:** Do not press transmitter during limit adjustment process.

## 8.6 Pedestrian access position

After completing the above procedure, the Pedestrian access position is automatically set to a position which is five (5) seconds from the fully closed position of the gate. The position can be manually set by following the SETTING PEDESTRIAN POSITION procedure (See Section 12).

## 8.7 Errors during setting of travel limit

During the above procedure, many error checks are performed. If an error is detected, a message will be displayed indicating the error.

## 8.8 Recalculate Force Margins

- a. Reprofileing is a simplified way of re-learning the travel characteristic of a previously setup Limit Switch travel installation. Re-profiling can be used when the travel characteristics of the gate change due to mechanical adjustments etc.
- b. To initiate a re-profile simply locate "MENU 10.2 Reprofile Travel"

**WARNING:** The gate(s) will automatically close and open. Ensure that no persons or objects are in the gates path.

- c. Press SET then follow the prompts. The gate will start to move and re-calculate force margins. The gate can move between the open and close limit positions up to two (2) times (depending on the position of the gate and the power up condition).
- d. A single beep will be heard once the process is complete and setup complete message will be displayed

# 9. Safety Obstruction Force Test



**WARNING! Take care when testing or adjusting the Safety Obstruction Force. Excessive force may cause SERIOUS PERSONAL INJURY and/or PROPERTY DAMAGE.**

## 9.1 Testing Close Cycle

1. Press the OPEN button to open the gate.
2. Place a piece of timber approximately 40mm wide on the ground directly next to the closing pylon / fence (**Fig. 9.1**).
3. Press the CLOSE button to close the gate. The gate should strike the object and start to re-open.

## 9.2 Testing Open Cycle

1. Press the CLOSE button to close the gate.
2. Press the OPEN button to open the gate. When the gate reaches the half open point, grab the side rail of the gate firmly and the gate should stop.
3. If the gate does not reverse readily when closing, or stop when opening, the force may be excessive and need adjusting.



**WARNING! If the gate fails these tests, put the opener into manual mode, only operate the gate by hand and call for service.**

## Safety Obstruction Force

The Safety Obstruction Force is calculated automatically during setup. Adjusting this is normally only necessitated by environmental conditions such as windy or dusty areas, and areas with extreme temperature changes.

## 9.3 Force Pressure For Close and Open Cycle.

### Navigating To "Current Trips"

1. Press NEXT or PREV to navigate to Menu 2 Current Trips.
2. Press SET (**Fig.9.2**)
3. MENU 2.1: CLOSE Margin is displayed (**Fig. 9.3**).
4. Press UP arrow to increase or DOWN arrow to decrease the value.
5. Press SET to save the new value.
6. Test the force again as per "Safety Obstruction Force Test" in Section 9.1.

## 9.4 Reprofile Travel

- a. Reprofile is a simplified way of re-learning the travel characteristic of a previously setup Limit Switch travel installation. Re-profiling can be used when the travel characteristics of the gate changes due to mechanical adjustments etc. To initiate a re-profile, simply locate "MENU 10.2 Repofile Travel", press SET and follow the prompts. The gate will start to move and re-calculate force margins. The gate can move between the open and close limit positions up to two (2) times (depending on the position of the gate and the power up condition).
- b. A single beep will be heard once the process is complete.
- c. Test the force again as per "Safety Obstruction Force Test" (Section 9.1 and 9.2).

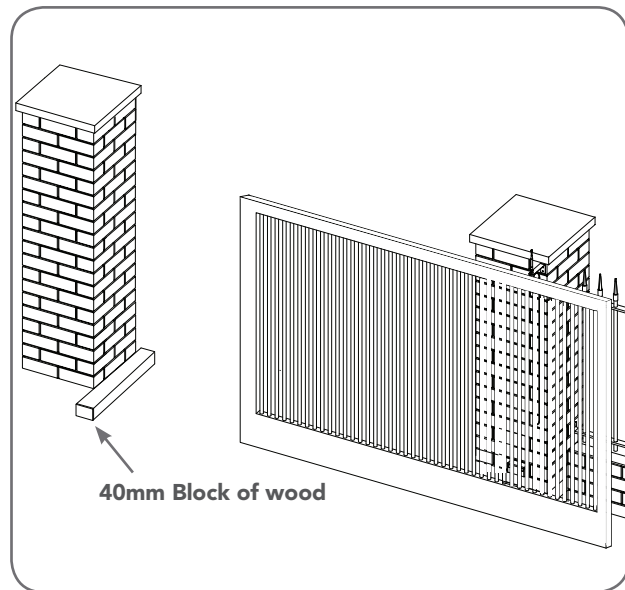

Fig 9.1

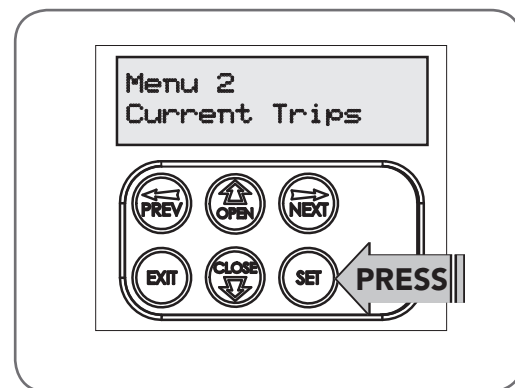

Fig 9.2

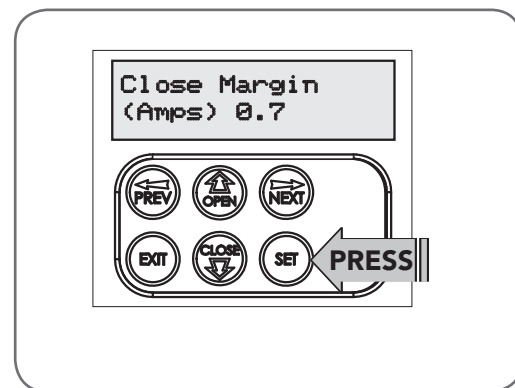

Fig 9.3

# 10. Coding Transmitter

NeoSlider™ can store up to thirty (30) transmitters in its memory. Each transmitter can be allocated an alpha-numeric ID label up to eleven (11) characters in length and each button can be assigned to one of several control functions. The settings for a transmitter are represented in (Fig. 10.1). It shows the transmitter's store number, ID label or serial number and the functions assigned to each of its four buttons. To toggle between ID/SN display, press UP/DOWN with the cursor on the ID/SN indicator. The procedures below code, delete, replace, edit and copy transmitter records.

**IMPORTANT NOTE:**  
Only TrioCode™128 Technology Transmitters are compatible with this product.

## 10.1 Coding Transmitter Button

Navigating To Menu 1 "Code Transmitter"

1. Press NEXT to navigate to Menu 1 (Fig. 13.2).
2. Press SET to enter the code set procedure.

Storing Transmitter Code

- a. The controller will prompt to press one of the transmitter's buttons.
- b. Press the transmitter button you wish to use to operate the Gate Opener (e.g. button 1) (Fig. 10.3).
- c. Press the same transmitter button again as prompted by the display (Fig. 10.4).

## 10.2 Selecting Function Of The Button

The controller will now show the transmitter's record, with a cursor on the field for the button being coded (Fig. 10.5). Use UP/DOWN arrows to select the function for the button.

**Available functions:**

- |                         |                       |
|-------------------------|-----------------------|
| VAC (Vacation Mode)     | LGT (Courtesy Light)  |
| STP (Stop)              | OPN (Open)            |
| CLS (Close)             | SWP (Swipe)           |
| PED (Pedestrian access) | OSC (Open/Stop/Close) |
| OFF (No action)         |                       |

Press SET to save the settings or EXIT to abort without saving (Fig. 10.6).

## 10.3 Returning To Main Screen

The "Code Transmitter" menu will now be shown. Press EXIT to return to the MAIN SCREEN and test the transmitter.

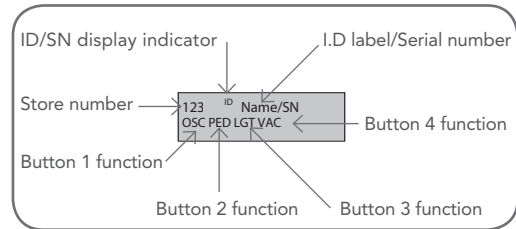

Fig 10.1

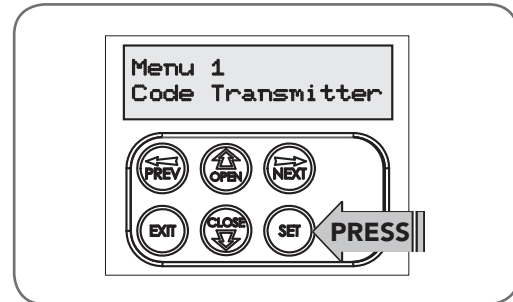

Fig 10.2

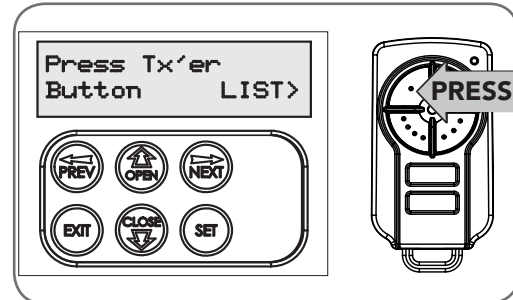

Fig 10.3

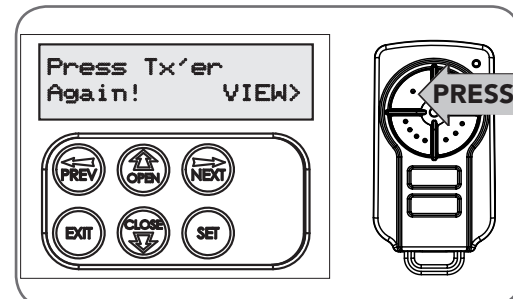

Fig 10.4

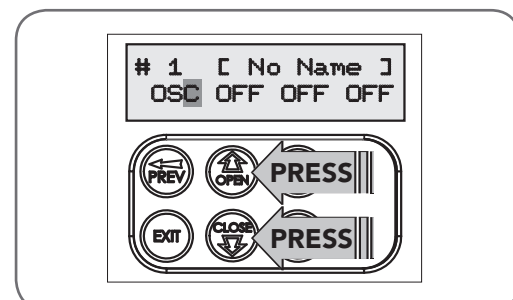

Fig 10.5

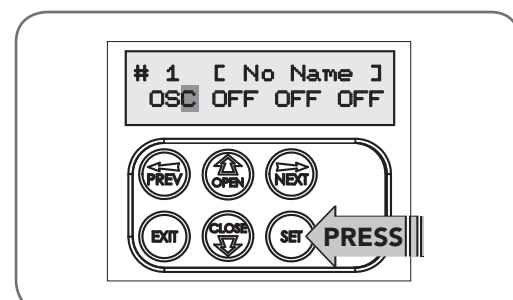

Fig 10.6

# 11. Remotely Coding Transmitters

Fig 11.1

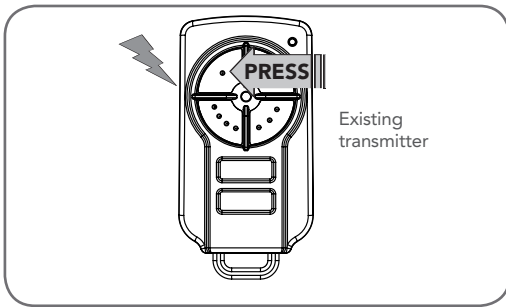

Fig 11.2

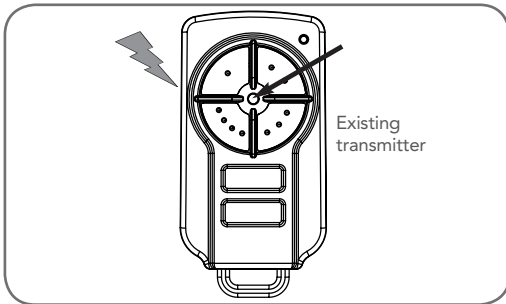

Fig 11.3

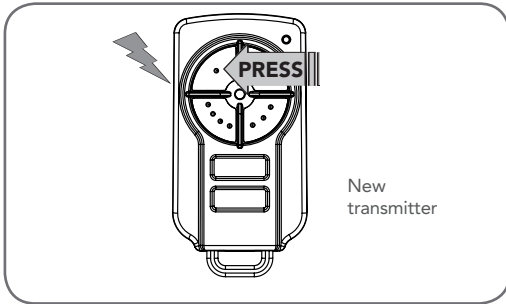
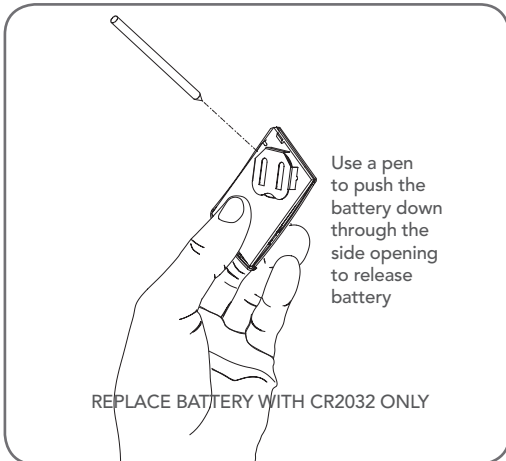

Fig 11.4



If a TrioCode™128 transmitter is already coded into the opener, additional TrioCode™ 128 transmitters can be coded without being in direct contact with the NeoSlider™.

**NOTE:** Only the function of the existing TrioCode™128 Transmitter button can be assigned to new transmitter. Please read instructions prior to proceeding - there is a time-out facility for security reasons.

## 11.1 Selecting The Function To Be Coded

1. Using the existing transmitter, operate the gate with the transmitter button which has the function to be coded (**Fig. 11.1**) (e.g. Button 1 has been coded with the OSC function assigned).
2. If the button's function activates the gate (PED, SWP, OSC, CLS, STP or OPN) wait for the gate to complete its cycle.

## 11.2 Activate Remote Code Set Mode

3. Use a small pin to press and hold through the Coding Hole of the existing transmitter for 2 seconds (**Fig. 11.2**).
4. Within 10 seconds, press the button on the new transmitter you wish to code for 2 seconds (**Fig. 11.3**).
5. Press the same button again (within 10 seconds) for confirmation.
6. Test Operation. The new transmitter button should now function as the existing transmitter.

**NOTE:** When a transmitter is remotely coded, its ID label is set to that of the existing transmitter. If the existing transmitter does not have an ID label assigned, then the ID label of the new transmitter is set to: R/C Tx ###, where ### is the existing transmitters store number. This ensures that the originator of any remotely coded transmitter can be identified.

## 11.3 Removing the Battery From the Transmitter

(Battery Type: 3V Lithium Battery CR2032).

Use a non-metallic object (e.g. pen) to remove the battery. (**Fig. 11.4**).

To test the battery is working, press and hold a transmitter button; (**Fig.11.5**).

| Light Status | Battery Status       |
|--------------|----------------------|
| Solid        | OK                   |
| Flashing     | Requires replacement |
| No light     | Requires replacement |

Fig 11.5



# 12. Setting Pedestrian Position

NeoSlider™ can be instructed, via its pedestrian control feature, to partly open and provide pedestrian access but prevent vehicle access.

**NOTE:** Before setting the pedestrian access position the gate must be in the fully closed position. As with the Setting Travel Limit procedure, a transmitter can be used to complete the pedestrian position setting procedure.

**NOTE:** The pedestrian default position is set at five (5) seconds from fully closed position and can be changed as follows:.

## 12.1 Navigating to "Menu 10.3 Set Pedestrian"

1. Press PREV to navigate to Menu 10.
2. Press SET - MENU 10.1 is displayed.
3. Press NEXT to go to MENU 10.3.
4. Press SET to enter Set Pedestrian procedure (Fig. 12.1).

## 12.2 Setting pedestrian position

- a. Press OPEN to change the pedestrian access position time (Fig. 12.2).
- b. Press SET to record new time.
- c. Press transmitter coded for pedestrian function to test.

## 12.3 Pedestrian Position Set

The controller will return to the MAIN SCREEN with the gate status shown as being in pedestrian access mode (Fig. 12.3).

## 12.4 Error Displays

During the above procedure many error checks are performed. If an error is detected, a message will be displayed indicating the error.

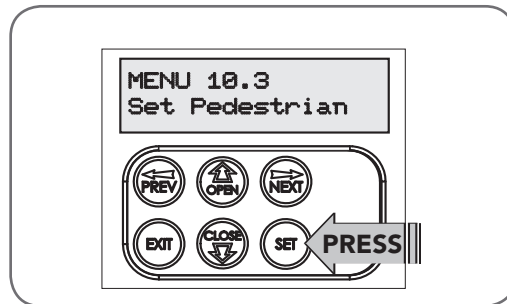

Fig 12.1

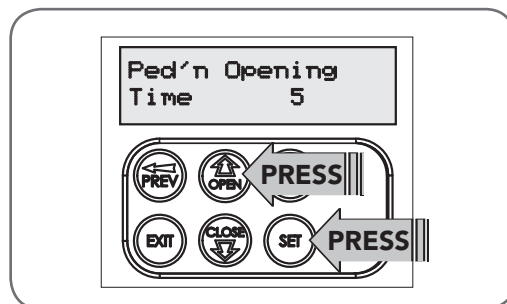

Fig 12.2

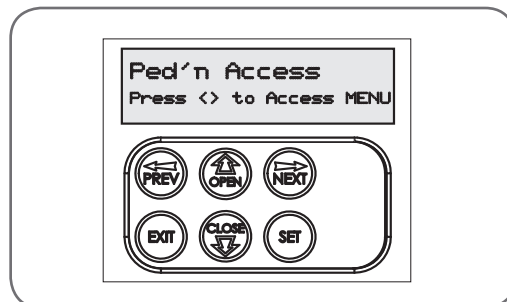

Fig 12.3

# 13. Auto-Close Mode



**WARNING! The Auto-Close function is not available unless Safety Beam is installed.**

## 13.1 Setting Up Standard Auto-Close

### Menu 3. Auto-Close Times

Auto-Close mode is a function that automatically closes the gate a preset time after the Safety Beam recognise that a vehicle has left the gateway. The Auto-Close timer only starts after the Safety Beam path is broken and the Auto-Close timer has been set. If the Safety Beam path is not broken, the gate will remain open until the path is broken. If the opener incurs a physical obstruction (i.e. not from the Safety Beam) while closing, the gate will re-open and not Auto-Close until the Safety Beam path is broken again.

#### Menu 3.1 Auto-Close

This mode is selected by entering a non-zero time for the STD Auto-Close parameter. When selected, the gate will Auto-Close after being fully opened (except when the gate has reversed to the open position after a motor obstruction or overload unless A/C after open and/or close Obstruction are selected). Countdown is suspended by: S.B., OPN or SWP input being active. The countdown is aborted if the STP input is activated. If the gate is already open and the OPN or the SWP input is activated, then the countdown will start.

## 13.2 Safety Beam Triggered Auto Close

### Menu 3.2 (SB AC Trig)

This mode is selected by entering a non-zero time for the "Safety Beam Auto-Close" parameter. This mode is used to Auto-Close the gate but only after an object has passed through the gateway and has triggered the Safety Beam input. Any Safety Beam or combination of Safety Beams can be configured to activate Safety Beam Auto-Close mode and combinations are:

#### One Beam only

- i. Safety Beam 1
- ii. Safety Beam 2

#### Either Beam

- i. Safety Beam 1 or Safety Beam 2

#### Combination

- ii. Safety Beam 1 and Safety Beam 2
- iii. Safety Beam 2 then Safety Beam 1

**NOTE:** The swipe input can be used to clear the Safety Beam triggered status so that the Safety Beam input must be activated again before the countdown will start. As with the other Safety Beam modes, the STP input will abort countdown and the OPN and SWP inputs will restart the countdown if the gate is OPEN.

## 13.3 Pedestrian Auto-Close

### Menu 3.3 Safety Beam Auto-Close

This mode is selected by entering a non-zero time for the "Safety Beam Auto-Close" parameter. This mode is used to Auto-Close the gate but only after an object has passed through the gateway and has triggered the Safety Beam input

### Menu 3.4 Pedestrian Auto-Close

This mode is selected by entering a non-zero time for the "Ped'n A/C" parameter. When selected, the gate will Auto-Close after being opened for pedestrian access unless it was following a reverse from an obstruction.

### Menu 3.5 (Safety Beam) Pedestrian Triggered Auto-Close

This mode is selected by entering a non-zero time for the "Safety Beam Pedestrian Auto-Close" parameter. Any Safety Beam or combination of Safety Beams can be configured to activate Safety Beam Auto-Close mode and combinations are:

#### One Beam only

- iv. Safety Beam 1
- v. Safety Beam 2

#### Either Beam

- i. Safety Beam 1 or Safety Beam 2

#### Combination

- ii. Safety Beam 1 and Safety Beam 2
- iii. Safety Beam 2 then Safety Beam 1

## Menu 3.6 (Safety Beam) Pedestrian Auto-Close

This mode is selected by entering a non-zero time for the "Ped'n A/C" parameter. When selected, the gate will Auto-Close after being opened for pedestrian access but only after an object has passed through the gateway and has triggered the Safety Beam input.

## 13.4 Auto-Close After Obstruction:

Two parameters are provided to enable the Auto-Close feature to be activated after obstructions and power up. Normally the Auto-Close feature is not enabled after obstructions for safety reasons. Safety Beams must be used for these features to be activated.

### Menu 3.7

This mode enables the Auto-Close feature to be activated when a close obstruction occurs (requires Safety Beams).

### Menu 3.8

This mode enables the Auto-Close feature to be activated when an open obstruction occurs.

### Menu 3.9

This mode enables Auto-Close feature after power up.

# 14. Accessories Installation

## Wiring Output1 And Output2

Outputs 1 and 2 are used to control a lock, Light or Safety Beam power. Which output is to control which function and the way it is controlled is programmable. If using these outputs make sure that the functions are configured for correct operation prior to setting the travel limits. OUTPUT1 or OUTPUT2 is used to activate an optional external relay module (RO-1) which in turn is used to switch the load.

### 14.1 Fitting Solenoid Or Magnetic Locks

Install the lock mechanism on the gate as per the manufacturers instructions. See **Fig. 14.1** for the wiring diagram.

#### Menu 4. Lock Times

Lock output can be programmed for both hold and pulse mode. The operation of the lock can be programmed to activate prior to the gate and behave differently on open cycles to that on close cycles.

1. Press NEXT or PREV on the wall control unit to navigate to Menu 4 Lock Times.
2. Press SET to select the sub menu.
3. Press NEXT or PREV to navigate through the sub menu.
4. Press OPEN to increase or CLOSE to decrease the time.
5. Press SET to save the new time.
6. Press the EXIT button two times to exit and test the locks operation.

### 14.2 Fitting Courtesy Lights

An AC or DC courtesy light can be activated via an output on the gate opener control board. Connect the light as per the diagram. (**Fig. 14.2**)



**WARNING: A qualified electrician must perform the installation where 240V AC power is used.**

#### Menu 5. Light Times

- a. Press NEXT or PREV on the wall control unit to navigate to Menu 5 Light/Lock Times.
- b. Press SET to select the sub menu.
- c. Press NEXT or PREV to navigate through the sub menu.
- d. Press OPEN to increase or CLOSE to decrease the time.
- e. Press SET to save the new time.
- f. Press the EXIT button two times to exit.
- g. Test the light operation.

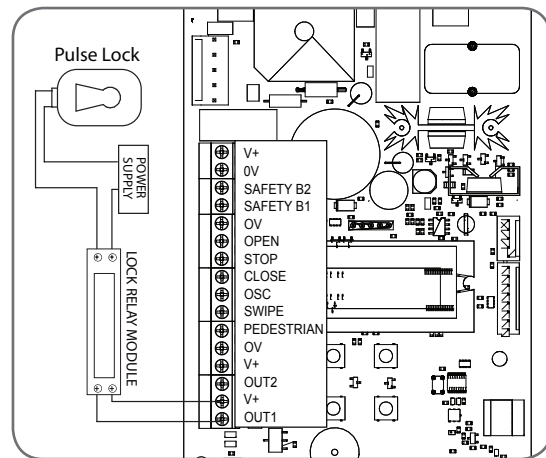

**Fig 14.1**

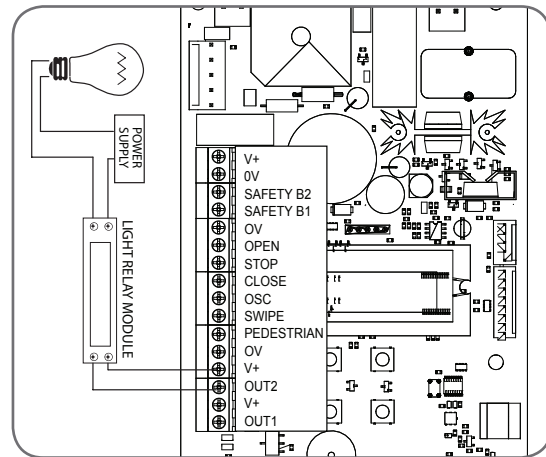

**Fig 14.2**



# 15. Specifications

| Technical Specifications                    |                   |                                 |
|---|-------------------|---------------------------------|
| Protection rating:                          |                   | IP33                            |
| Input voltage:                              |                   | 230V - 240V AC 50Hz             |
| Transformer primary voltage:                |                   | 230V/240VAC                     |
| Secondary voltage:                          |                   | 24V AC 150 VA                   |
| Controller voltage:                         |                   | 24V DC                          |
| Motor type:                                 |                   | Permanent Magnet Direct Current |
| Motor voltage:                              |                   | 24V DC                          |
| Maximum pulling force:                      |                   | 200N                            |
| Maximum gate opening: <sup>1</sup>          | Width:<br>Weight: | 10m<br>250kg                    |
| Opener maximum<br>Opening/closing run time: |                   | 30 seconds                      |
| Receiver type:                              |                   | TrioCode™128                    |
| Receiver code storage capacity:             |                   | 30 x 4 Button Transmitter Codes |
| Transmitter frequency:                      |                   | 433.47, 433.92, 434.37 MHz      |
| Coding type:                                |                   | Hopping Code                    |
| No. of code combinations:                   |                   | Over 100 billion random codes   |
| Code generation:                            |                   | Non-linear encryption algorithm |
| Transmitter battery:                        |                   | CR2032                          |

**NOTE:**

1. The maximum gate size that the NeoSlider™ can be installed on is 10m wide and 250kg. The gate must be well balanced. A person should be able to move the gate manually with very little effort (15kg force max.) in case of an emergency.
2. Intermittent operations may occur in areas which experience very strong wind gusts. A strong wind puts extra pressure on the gate and tracks which may in turn trigger the safety obstruction detection system intermittently.

**NOTE:** Specifications are subject to change without notice.



# 16. Troubleshooting

| Symptom  | Possible cause  | Remedy  |
|--|---|---|
| Gate will not operate  | Mains power not switched on.  | Switch on mains power.  |
|  | Opener motor is disengaged  | Check that the motor is engaged for automatic operation   |
|  | Gate is obstructed.   | Remove obstruction.   |
|  | The opener is in "Vacation Mode"  | Turn off "Vacation Mode"(Appendix C Menu 7.4).  |
| Gate starts to close but automatically reverses to open position | Adverse weather conditions (wind or cold) causing gate to stiffen and become tight in the tracks. | Increase force margin setting (Section 9.4)   |
|  | Possible obstruction in the gateway triggering Safety Beams.                                      | Remove obstruction  |
| Gate operates from opener but not from transmitter               | Transmitter code not stored in memory.  | Code transmitter in to openers memory. (Section 10.1)   |
|  | Transmitter does not contain TrioCode™ 128 Technology   | Check the transmitter. It should have grey buttons and the model number should display V2. Contact dealer for support if otherwise. |
|  | Flat battery in transmitter   | Replace battery (Section 11.3)  |
|  | Antenna behind structure (gate or fence) or not in line of sight                                  | Ensure Antenna is in line of sight (Section 4.2)  |
| Gate does not close with transmitter                             | Safety Beam not working properly.   | Make sure Safety Beams are operational. and no dirt is on the lens.   |
| Gate will not close fully.                                       | Gate limit positions need to be reset.  | Reset limits positions.   |
|  | Gate obstructed and reverses  | Clear obstruction or adjust force margin (Section 9.3)  |
| Gate will not open fully.  | Gate limit positions need to be reset.  | Reset limits positions. (Section 8)   |
|  | Gate obstructed.  | Clear obstruction or adjust force margin (Section 9.3)  |
| Auto-Close not working   | Safety Beam not installed.  | Install Safety Beam. (Section 6)  |
|  | Safety Beam or wiring faulty.   | Repair Safety Beam or replace wiring.   |
|  | Safety Beam not aligned correctly.  | Re-align optics.  |
|  | Safety Beam is obstructed.  | Remove obstruction from path of Safety Beams.   |
|  | Gate obstructed when closing.   | Remove obstruction.   |
|  | Auto-Close time not set.  | Set Auto-Close times (Section 13.3).  |
|  | Auto-Close mode not set   | Set Auto-Close mode. (Section 13.2)   |



# 17. Appendix

## A - Console Menu Structure

### OPERATIONAL BUTTONS:

1. Press PREV/NEXT buttons move to Left/Right.
2. Press OPEN/CLOSE buttons to change setting.
3. Press SET button to save changes.
4. Press EXIT to return to MENU without saving changes.

| Parameter   | Min | Max   | Default | Step | Unit  | Menu | Section |
|---|-----|-------|---------|------|-------|------|---------|
| Menu 1 - Code Transmitter   |     |       |         |      |       |      |         |
| STORING TRANSMITTERS  | 0.0 | 511   |         |      |       | 1    | 10.1    |
| Menu 2 - Current Trips  |     |       |         |      |       |      |         |
| M1 MARGIN<br>Sets obstruction detection margin for M1                                     | 0.0 | 4.0   | 0.7     | 0.1  | AMPS  | 2.1  | 9.3     |
| SETTLE TIME disable the obstruction detection in the start of the cycle                   | 0.1 | 2.0   | 1.0     | 0.1  | SEC   | 2.2  |         |
| Menu 3 - Auto Close   |     |       |         |      |       |      |         |
| STD AUTO-CLOSE TIME<br>Sets and enables the standard Auto-Close time                      | 0.0 | 300.0 | 0.0     | 1.0  | Sec   | 3.1  | 13.1    |
| SAFETY BEAM AUTO-CLOSE TIME Sets and enables the SB triggered Auto-Close time             | 0.0 | 60.0  | 0.0     | 1.0  | Sec   | 3.3  | 13.2    |
| PEDESTRIAN AUTO-CLOSE TIME Sets and enables the Pedestrian Auto-Close time                | 0.0 | 60.0  | 0.0     | 1.0  | Sec   | 3.4  | 13.3    |
| SAFETY BEAM PEDESTRIAN AUTO-CLOSE TIME Sets and enables the SB Pedestrian Auto-Close time | 0.0 | 60.0  | 0.0     | 1.0  | Sec   | 3.6  | 13.3    |
| AUTO-CLOSE AFTER CLOSE OBSTRUCTION<br>Enables Auto-Close feature after close obstructions | Off | On    | Off     |      |       | 3.7  | 13.4    |
| AUTO-CLOSE AFTER OPEN OBSTRUCTION<br>Enables Auto-Close feature after open obstructions   | Off | On    | Off     |      |       | 3.8  | 13.4    |
| AUTOCLOSE AFTER POWERUP<br>Enables autoclose feature after powerup                        | Off | On    | Off     |      |       | 3.9  | 13.4    |
| Menu 4 - Lock Times   |     |       |         |      |       |      |         |
| OPEN LOCK TIME Set the time the lock is activated for on open cycles                      | 0.0 | Hold  | 0.5     | 0.1  | Sec   | 4.1  | 14.1    |
| CLOSE LOCK TIME Set the time the lock is activated for on close cycles                    | 0.0 | Hold  | 0.5     | 0.1  | Sec   | 4.2  | 14.1    |
| PRE-OPEN LOCK TIME Time the lock is activated for prior to opening                        | 0.0 | 25.5  | 0.0     | 0.1  | Sec   | 4.3  | 14.1    |
| PRE-CLOSE LOCK TIME Time the lock is activated for prior to closing                       | 0.0 | 25.5  | 0.0     | 0.1  | Sec   | 4.4  | 14.1    |
| Menu 5 - Light Times  |     |       |         |      |       |      |         |
| ON AFTER CYCLE LIGHT TIME - Time light remains on for after a cycle                       | 0   | 255   | 60      | 1    | Sec   | 5.1  | 14.2    |
| ON BEFORE OPEN CYCLE LIGHT TIME<br>Minimum time light is activated for prior to opening   | 0   | 255   | 0       | 1    | Sec   | 5.2  | 14.2    |
| ON BEFORE CLOSE CYCLE LIGHT TIME<br>Minimum time light is activated for prior to closing  | 0   | 255   | 0       | 1    | Sec   | 5.3  | 14.2    |
| Menu 6 - Motor Settings   |     |       |         |      |       |      |         |
| OPEN SPEED VOLTS<br>Voltage applied to motors when opening                                | 12  | 24    | 22      | 1    | VOLTS | 6.1  |         |
| CLOSE SPEED VOLTS<br>Voltage applied to motors when closing                               | 12  | 24    | 20      | 1    | VOLTS | 6.2  |         |
| SLOW SPEED VOLTS<br>Voltage applied to motors when slowing down                           | 6   | 24    | 8       | 1    | VOLTS | 6.3  |         |
| SLOW TIME<br>The time between slow down and end of cycle                                  | 0.1 | 10.0  | 3.0     | 0.1  | SEC   | 6.4  |         |
| HOMING / SETUP SPEED VOLTS<br>Voltage applied to motors when setting up the travel limits | 12  | 24    | 12      | 1    | Volts | 6.5  |         |
| STOP PAUSE TIME<br>Pause time used between motor direction changes                        | 0.0 | 2.0   | 0.3     | 0.1  | SEC   | 6.6  |         |



# Appendix

**NOTE:** The System will automatically return to the main screen after 30 secs if a menu screen is displayed and no buttons are pressed.

## A - Console Menu Structure

| Parameter  | Option   | Default         | Menu | Section    |
|--|--|-----------------|------|------------|
| Menu 7 - Operating Modes   |  |                 |      |            |
| SB1 TYPE   | 2 WIRE<br>3 WIRE   | 2 WIRE          | 7.1  | Appendix C |
| SB2 TYPE   | 2 WIRE<br>3 WIRE   | 2 WIRE          | 7.2  | Appendix C |
| SB1 INPUT MODE<br>Sets the Input mode for Safety Beam 1.<br>Only one option can be selected. | NOT USED,<br>CLS TO REV<br>CLS TO STOP<br>OPN/CLS TO STOP<br>OPEN INPUT<br>SWIPE INPUT<br>CLOSE INPUT<br>PED INPUT<br>DISABLED | NOT USED        | 7.3  | Appendix C |
| SB2 INPUT MODE<br>Sets the Input mode for Safety Beam 2.<br>Only one option can be selected. | NOT USED,<br>CLS TO REV<br>CLS TO STOP<br>OPN/CLS TO STOP<br>OPEN INPUT<br>SWIPE INPUT<br>CLOSE INPUT<br>PED INPUT<br>DISABLED | NOT USED        | 7.4  | Appendix C |
| PED INPUT = SWIPE MODE Selects PED input functions as pedestrian access swipe input          | Off  | Off             | 7.5  | Appendix C |
| OPN INPUT N/C OPERATION<br>Selects operating polarity of OPN input                           | Off  | Off             | 7.6  | Appendix C |
| STP INPUT N/C OPERATION<br>Selects operating polarity of STP input                           | Off  | Off             | 7.7  | Appendix C |
| REMOTE CODE ENABLED<br>Selects remote transmitter coding function                            | On   | On              | 7.8  | Appendix C |
| VACATION MODE<br>Selects vacation mode - disables remote control                             | Off  | Off             | 7.9  | Appendix C |
| BATTERY/SOLAR MODE<br>Selects Battery Backup/Solar operation                                 | BATTERY ENABLED<br>SOLAR ENABLED   | BATTERY ENABLED | 7.10 | Appendix C |
| PASSWORD<br>Selects password protection for all changes                                      | Off  | Off             | 7.11 | Appendix C |
| TX # GROUPING<br>Selects transmitter number group display format.                            | Off  | Off             | 7.12 | Appendix C |
| OUTPUTS 1 MODE<br>Selects function of OUTPUT1  | LOCK DRIVE<br>LIGHT DRIVE<br>3 WIRE SB 0V<br>NOT USED  |                 | 7.13 | Appendix C |
| OUTPUTS 2 MODE<br>Selects function of OUTPUT2  | LOCK DRIVE<br>LIGHT DRIVE<br>3 WIRE SB 0V<br>NOT USED  |                 | 7.14 | Appendix C |
| FAULT AUTO RESET   | Off  | Off             | 7.15 | Appendix C |
| SBFEC MODE   | AVAILABLE<br>DISABLED  | AVAILABLE       | 7.16 | Appendix C |

# Appendix

## A - Console Menu Structure

| Parameter                                   | Option | Default  | Menu | Section    |
|---|--------|----------|------|------------|
| Menu 8 - Diagnostics                        |        |          |      |            |
| TEST INPUTS - Controls input display status |        | Inactive | 8.1  | Appendix D |
| TEST TRANSMITTERS (TX'ERS)                  |        |          | 8.2  | Appendix D |
| DISPLAY HISTORY                             |        |          | 8.3  | Appendix D |
| MEMORY USAGE                                |        |          | 8.4  | Appendix D |
| SERVICE COUNTER                             |        | 60,000   | 8.5  | Appendix D |
| EVENT COUNTER                               |        |          | 8.6  | Appendix D |
| Menu 9 - Memory Tools                       |        |          |      |            |
| CLR CONTROL                                 |        |          | 9.1  | Appendix E |
| CLR TRANSMITTERS (TX'ERS)                   |        |          | 9.2  | Appendix E |
| Menu 10 - Setup Travel                      |        |          |      |            |
| LIMIT TRAVEL                                |        |          | 10.1 | 8.1        |
| REPROFILE TRAVEL                            |        |          | 10.2 | 9.5        |
| SET PEDESTRIAN                              |        |          | 10.3 | 12.1       |





# Appendix

## B - Viewing and Editing Parameters

Fig B.1

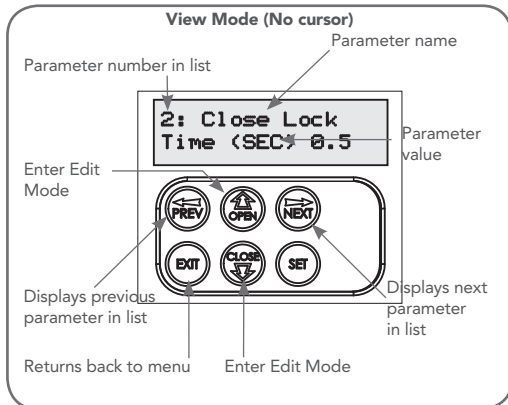
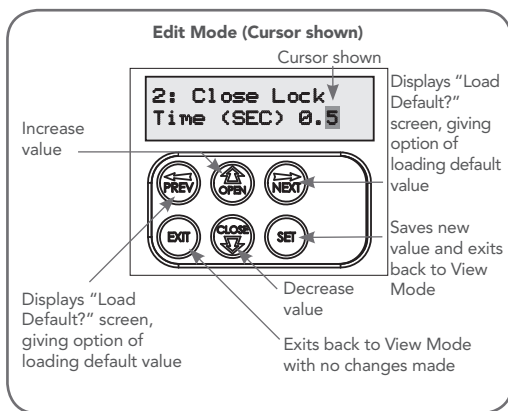

Fig B.2



This section illustrates how to locate, view and adjust parameters.

### Locating parameters

Refer to Appendix A for Console Menu Structure. Locate the required parameter and note the MENU number. The example used in (Fig. B.1) displays "CLOSE LOCK TIME"

### Changing Setting

1. Press NEXT/PREV to navigate to the required menu.
2. Press SET to show the sub-menu.
3. Press NEXT/PREV to go to the required sub-menu.
4. Press OPEN/CLOSE to change parameter setting. Holding the button down causes the parameter's value to change rapidly. The longer the button is held the faster the value changes.
5. Press SET to SAVE setting.

### Reload Default Setting

1. Press NEXT/PREV buttons to display LOAD DEFAULT screen.
2. Press SET to load the default value.

### Return To Menu

If the parameter values are not to be changed, press EXIT to return to sub menu. Press EXIT again to return to the MAIN SCREEN.



# Appendix

## C - Control Board Adjustments

The standard operation of the opener can be altered by editing various parameters. This section describes the parameters and the effect they have. Use the VIEWING AND EDITING PARAMETER PROCEDURE (Appendix B) to make changes.

### Menu 6. Motor settings

#### Motor speed

The maximum speed the motors run at is controlled by the MOTOR FULL SPEED VOLTAGE parameter. The default value is the maximum recommended for normal operation. If however the gates move too quickly for a particular installation, the voltage can be reduced to make the motors run slower. **NOTE: Altering these parameters will cause the travel limits to be cleared.**

### Menu 7. Operating Modes

#### Menu 7.1 First (SB1) Safety Beam Type

Select what type of Safety Beam (2 WIRE or 3 WIRE). 2 WIRE is default.

#### Menu 7.2 Second (SB2) Safety Beam Type

Select what type of Safety Beam (2 WIRE or 3 WIRE). 2 WIRE is default.

#### Menu 7.3 First (SB1) Safety Beam Response Mode

The Safety Beams input can be configured to respond in one of eight modes.

- i. **Not Used**
- ii. **Close to Reverse** In this mode, the Safety Beam input has no effect when opening but will cause the gate to reverse if activated when closing.
- iii. **Close to Stop** In this mode, the Safety Beam input has no effect when opening but will stop the gate when closing.
- iv. **Open and Close to Stop** In this mode, all cycles are prevented from being completed or initiated when the Safety Beam input is active.
- v. **Open input** In this mode, open cycle is initiated when the Safety Beam is activated.
- vi. **Swipe input** In this mode, open cycle is initiated when the Safety Beam is activated.
- vii. **Close input** In this mode, close cycle is initiated when the Safety Beam is activated.
- viii. **Ped input** In this mode, ped cycle is initiated when the Safety Beam is activated.
- ix. **Disabled** In this mode, Safety Beam is disabled.

#### Menu 7.4 Second Safety Beam (SB2) Response Mode

Same as above menu 7.3

#### Menu 7.5 PED Input Function

If GPI or Fire Input is selected as PED then these inputs can be configured to a SWIPE type input for pedestrian access. This provides full functionality with the Safety Beam Triggered Pedestrian Auto-Close function.

#### Menu 7.6 Open (Opn) Input

(Activated by OPN terminal with N/O switch, by transmitter button with OPN function assigned or by console's UP button) Activating the OPN input will cause the gate to open. Holding the input will prevent closing.

#### Menu 7.7 Stop (STP) Input

(Activated by STP terminal with N/O switch, by transmitter button with STP function assigned or by console's EXIT button) Activating the STP input while the gate is moving will cause the gate to be stopped. If the STP terminal is held it will prevent the gate from being moved.

#### Menu 7.8 Remote Code

The controller supports the Remote Code Set feature. This parameter can be used to disable the feature for security or transmitter management reasons.

#### Menu 7.9 Vacation Mode

Vacation mode blocks all but one designated remote transmitter from activating the NeoSlider™. The mode is activated by pressing a transmitter button with the VAC function assigned until the console displays that vacation mode is enabled (approx. 5 secs). When activated, any transmitter button which is assigned VAC will be ignored. To turn Vacation mode off, press a transmitter button with the VAC function assigned. Vacation mode can also be turned on or off manually by editing the VACATION MODE parameter.

#### Menu 7.10 Battery / Solar Mode

The controller can be instructed to turn off the Battery Backup / Solar facilities so that the control board can be shut down without having to disconnect the Battery Backup / Solar system.

#### Menu 7.11 Password Protection

The password feature enables all parameters and configuration settings to be protected unless a password is entered. When this feature is turned on, the user is requested to enter the desired password to be used. The password protection feature has a time-out that expires after 60 seconds of inactivity. Alternatively, the user may log out manually by pressing exit when the main screen is displayed.

# Appendix

## C - Control Board Adjustments

### Menu 7.12 Transmitter Grouping

The transmitter store number display format can be changed to show a grouped format. When grouping is selected, instead of displaying the store location as a number between 1 and 511, it will display as ##\$ where ## is the group number and \$ is a character a,b,c,d,e,f,g or h which indicates the group member.

### Menu 7.13 Output1 Mode

AUX output can be selected to be driven by:

- i. **Lock Drive:** Lock output can be programmed for both hold and pulse mode. The operation of the lock can be programmed to activate prior to the gate and behave differently on open cycles to that on close cycle.
- ii. **Light Drive:** a light relay module can be connected on the console between V+ and OUT2 terminal which will turn the courtesy light on and off.
- iii. **3 Wire Safety Beam 0V:** .
- iv. **Not Used**

### Menu 7.14 Output2 Mode

AUX output can be selected to be driven by:

- i. **Lock Drive:** Lock output can be programmed for both hold and pulse mode. The operation of the lock can be programmed to activate prior to the gate and behave differently on open cycles to that on close cycle.
- ii. **Light Drive:** a light relay module can be connected on the console between V+ and OUT2 terminal which will turn the courtesy light on and off.
- iii. **3 Wire Safety Beam 0V:**
- iv. **Not Used**

### Menu 7.15 Fault, Auto Reset

When selected, the controller will reset any fault automatically.

### Menu 7.16 Safety Beam Failure Emergency Close Mode (SBFEC)

When a safety beam prevents movement due to any reason other than a 'real' obstruction, the user can secure their property by pressing and holding a button on the remote control or OSC on the console. The button must be held active for more than five seconds to activate this mode and hold the button for the entire duration of close cycle.

# Appendix

## D- Diagnostic Tools

The controller provides several diagnostic tools from within the Diagnostics Menu (Menu 8). This section details the function of each tool and its use.

### Navigating To Diagnostics Menu

- Press PREV to navigate to Menu 8 (**Fig. D.1**).
- Press SET to display the menu of available functions.
- Press PREV or NEXT to cycle through diagnostic tools.
- Press SET to select.

### Menu 8.1 Test Inputs

This tool is used to view the state of the control inputs. When selected, a screen is displayed (**Fig. D.2**) which indicates the state of each input. If the name of the input is in upper case or number in the bracket, then the input is active. Conversely if the input is in lower case, then the input is inactive. For normal operation, all inputs should be inactive. When finished, press EXIT. The example shows the status as OSC input is active.

### Menu 8.2 Test Transmitters (Tx'ers)

This tool is used to test receiver/transmitter functionality. When selected, a screen is displayed which prompts for a transmitter button to be pressed (**Fig. D.3**) and whether ID or serial numbers are to be displayed.

The NeoSlider™ will then beep each time a transmission is received. If the transmitter button is stored in the NeoSlider™ memory and has a function assigned to it, a second screen will be displayed that shows the transmitter details along with the button pressed (**Fig. D.4**). The example shows the case where transmitter number 12 is activated by button 4. Note ID is selected for display.

### Menu 8.3 Display History

The NeoSlider™ keeps a record of the last 64 events that have taken place. The events include the type of drive cycles executed, obstruction detection, various faults, power failures etc. When this tool is selected, the screen displays the last event that occurred (**Fig. D.5**). Press NEXT or PREV to view each event. The "EVENT#" field shows the sequence of the events, with (1) being the first and (64) being the last. The example shows that the last event was a close cycle which succeeded in closing the gate. When finished viewing the events, press EXIT.

### Menu 8.4 Memory Usage

This tool displays the number of transmitter store locations used and the number free.

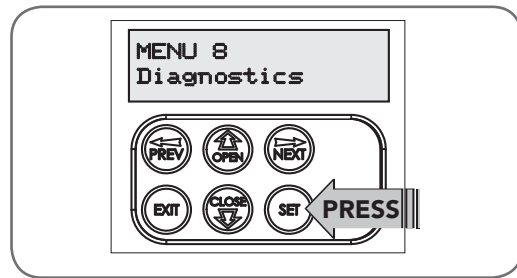

Fig D.1

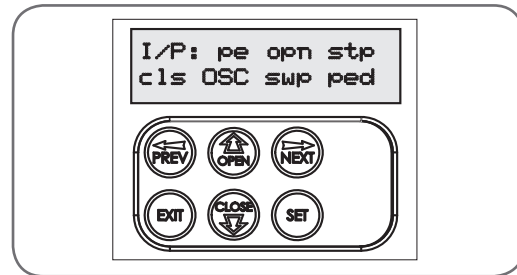

Fig D.2

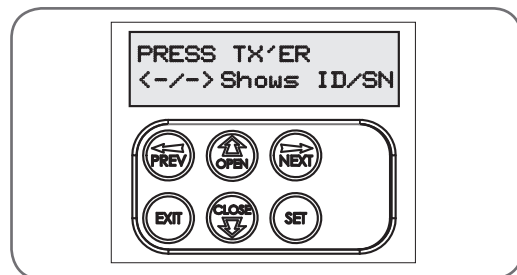

Fig D.3

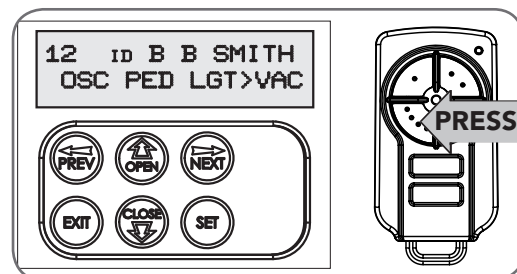

Fig D.4

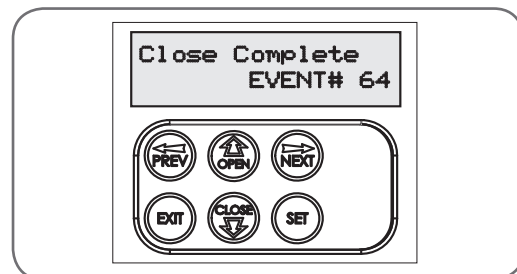

Fig D.5

# Appendix

## D- Diagnostic Tools

### Menu 8.5 Service Counter

The NeoSlider™ provides a periodic service counter which can be set to expire after a number of drive cycles. When expired, the NeoSlider™ will beep at the beginning of each drive cycle and a message will be displayed on the MAIN SCREEN (Fig. D.7). This tool displays the current value of the service counter and allows the user to set its value using the normal parameter editing techniques (See PARAMETER VIEWING AND EDITING). If the service counter is not to be used, it can be set to the maximum number (60,000).

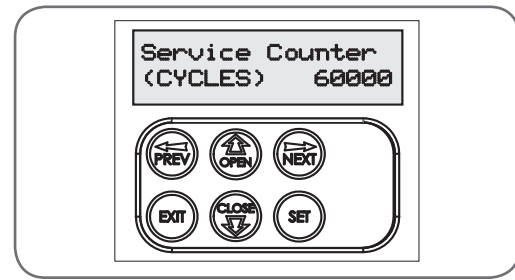

Fig D.7

### Menu 8.6 Event Counters

The opener keeps a count of number of times a particular event occurs. The list of event counters kept is shown below. When this tool is selected, the first event counter is shown (Fig. D.8). Press NEXT or PREV to step through the list. The example shows the OPEN CYCLE event counter with a value of 1234. When finished viewing press EXIT.

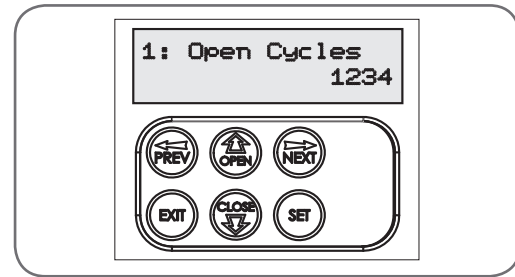

Fig D.8

- |                           |                          |
|---------------------------|--------------------------|
| 1: Open Cycles            | 2: Close Cycles          |
| 3: PED Cycles             | 4: Setup Limits          |
| 5: Comm's Loss            | 6: Sync Faults           |
| 7: Overlaps               | 8: M1 Open Stall         |
| 9: M1 Close Stall         | 10: M1 Open Obstructions |
| 11: M1 Close Obstructions | 12: M1 Open Overloads    |
| 13: M1 Close Overloads    | 14: M1 PWM Sync Faults   |
| 15: M1 PWM Drive Faults   | 16: M1 Direction Faults  |
| 17: M1 Sensor Faults      |                          |

# Appendix

## E - Memory Tools

The Memory Tools accessed from within Menu 9 (Fig E.1) are used to backup, restore or clear the controller. Once selected, the PREV or NEXT buttons can be used to view the Memory Tool options. To Execute the displayed option simply press SET.

### Menu 9.1 Clear Control

This option will clear the gate control memory and reload the factory set defaults for parameters such as the lock time, light time, auto-close times etc. It will also clear the travel limits.

### Menu 9.2 Clear Transmitters (Tx'ers)

This option will clear the transmitter storage memory.

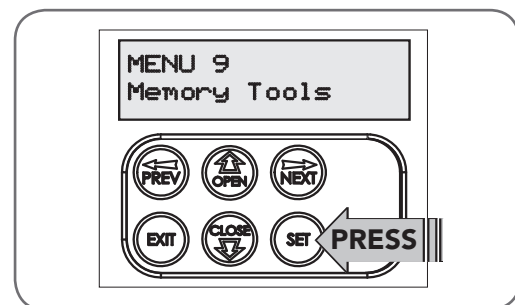
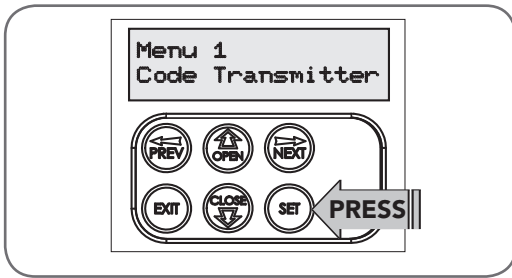

Fig E.1

# Appendix

## F- Transmitter Editing

Fig F.1



### Navigating To "Edit Transmitter" Menu

- Press NEXT to navigate to Menu 1 (**Fig. F.1**).
- Press SET to enter the transmitter edit procedure.
- Press NEXT to enter transmitter list and edit mode.

### Editing Button Function Field

- Press NEXT or PREV to move the cursor to the left or right and between the top and bottom lines to select the desired field.
- Press UP or DOWN arrows to change the displayed value. The available functions are shown below. Selecting OFF will prevent the opener responding to that button.

#### Available functions

|                         |                       |
|-------------------------|-----------------------|
| VAC (Vacation Mode)     | LGT (Courtesy Light)  |
| STP (Stop)              | OPN (Open)            |
| CLS (Close)             | SWP (Swipe)           |
| PED (Pedestrian access) | OSC (Open/Stop/Close) |
| OFF (No action)         |                       |

- Press SET to save changes or press NEXT or PREV to move to the next field. The example in (**Fig. F.2**) shows that PED is assigned to the transmitter button 2. The transmitter in the example is transmitter number 12 which has the ID label AB Smith.

**NOTE:** If all button functions are set to OFF, when SET is pressed, the opener will prompt to confirm if the transmitter is to be deleted. Press SET to delete or EXIT to continue editing.

### Editing The Store Location

This feature is only available when coding the first button of a new transmitter.

- Press NEXT or PREV to move the cursor over Store No. (**Fig. F.3**)
- Press UP or DOWN arrows to select new Store No.
- Press SET to Confirm or NEXT/PREV to move to the next field.

This is useful when managing transmitters using a scheme which ties the store location to the transmitter's owner.

### Selection Of ID or Serial Number Display

- Press NEXT to navigate to the Menu 1 "Code Transmitter".
- Press SET to enter the transmitter edit procedure.
- Press NEXT to enter transmitter list and edit mode.
- Press NEXT/PREV to move the cursor over the ID field.
- Press NEXT to reveal the Serial Number (**Fig. F.4**).

The serial number display is provided for additional means of identification. The transmitter in this example has serial number 12345.

### Editing A Character Field

- Press NEXT or PREV to move select character.
- Press UP or DOWN arrows to scroll through and select a new character.
- Press NEXT or PREV to move to the next character.
- Repeat step b.
- Press SET to record changes (**Fig. F.5**).

The second line of the display shows a list of available characters with the current value indicated at the cursor position.

Fig F.2

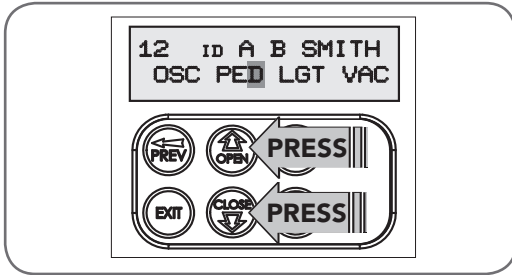

Fig F.3

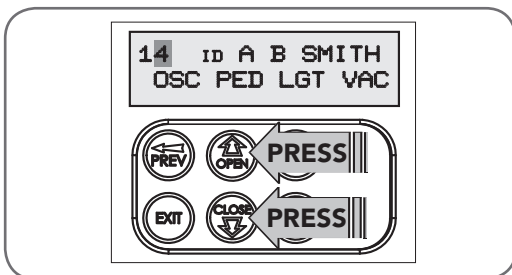

Fig F.4

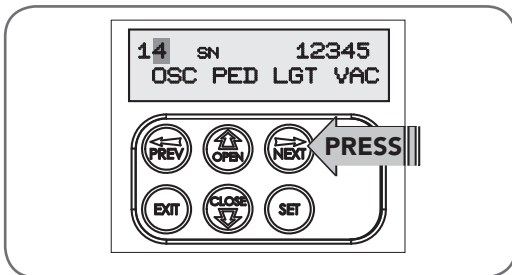
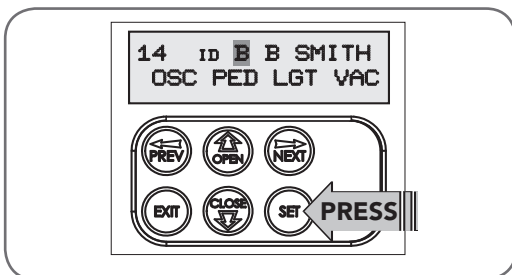

Fig F.5



# Appendix

## G- Transmitter Management

### Transmitter Listing Facility

The NeoSlider™ provides a transmitter listing facility which enables the user to find a transmitter location within the memory. Once located, a stored transmitter can be replaced, deleted, edited, copied or, if the location is empty, a new transmitter can be coded.

#### Method 1 - Go To The Start Of The List Accessing The List Menu

1. Press NEXT to navigate to Menu 1 (**Fig. G.1**).
2. Press SET to enter the transmitter edit procedure.
3. Press NEXT to enter the transmitter list and edit mode.

#### Method 2 - Use The Transmitter To Go Direct To The List Accessing The List Menu

- a. Press NEXT to navigate to Menu 1 (**Fig. G.1**).
- b. Press SET to enter the transmitter edit procedure.
- c. Press the transmitter once (**Fig. G.2**).
- d. Press NEXT to view the transmitter parameters. This method is used for quick navigation if the transmitter is available.

**NOTE:** "VIEW" will not be shown if the transmitter is not stored. Once the list is displayed, it can be sorted by stored number, ID Label or Serial Number. Use the NEXT or PREV buttons to select the sorting method.

**NOTE:** When sorting by ID label or S/N, only stored transmitters locations are displayed.

#### Navigating The List

- a. Press the UP or DOWN arrows to navigate through the list (**Fig. G.3**).

**NOTE:** Holding a button down will step through the list faster.

- b. Press SET to display the menu of available functions.

#### Selecting An Operation

- a. Press NEXT or PREV to cycle through the four menu options (**Fig G.4**)
- b. Press EXIT to return to the list.
- c. Press SET to execute the menu's operation.

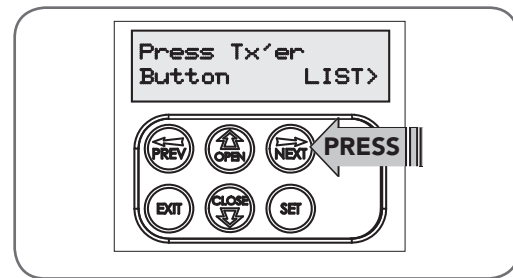

Fig G.1

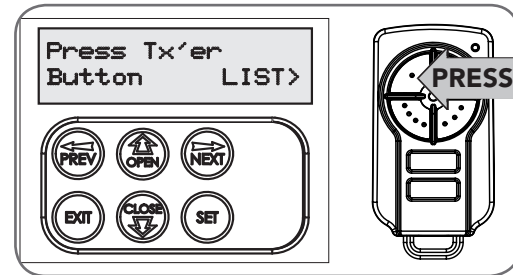

Fig G.2

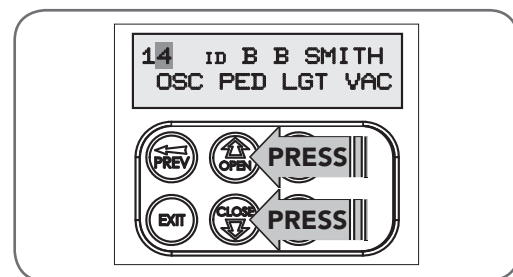

Fig G.3

| Menu Option                     | Operation  |
|---------------------------------|--|
| Code Operation (location empty) | If the code operation is selected on an empty transmitter location, the BASIC CODE TRANSMITTER PROCEDURE will be initiated with the transmitter being saved in the selected location. This is useful when managing transmitters using a scheme which ties the store location to the transmitter's owner.   |
| Code Operation (location used)  | If the code operation is selected for a location that already contains a transmitter, then the BASIC CODE TRANSMITTER PROCEDURE will be initiated and the new transmitter will replace the existing one. Note that the button functions and name of the existing transmitter will be transferred to the new transmitter. This procedure is of great convenience when replacing a lost transmitter. |
| Delete Operation                | The delete operation is used to remove a transmitter from memory along with the name and button function settings.   |
| Edit Operation                  | The edit operation displays the transmitter record for editing purposes. See TRANSMITTER EDIT PROCEDURE (Appendix F) for details.  |
| Copy Operation                  | The copy operation is used to code multiple transmitters with the same button function as that of the selected transmitter. Once selected an abbreviated code set routine is initiated which repeats steps 2 & 3 of the BASIC CODE TRANSMITTER PROCEDURE for each transmitter to be coded. Coding is terminated by pressing the EXIT button.   |
| Exiting The List                | To exit the transmitter list, simply press EXIT to return to the Code menu.  |

Fig G.4

# 18. Warranty and Exclusion of Liability

1. This Warranty is given by Automatic Technology (Australia) Pty Ltd (ABN 11 007 125 368) (ATA), 6-8 Fiveways Boulevard, Keysborough 3173, 1300 133 944, sales@automatictechnology.com.au
  2. The Competition and Consumer Act 2010 (including the Australian Consumer Law) and other relevant statutes provide a set of statutory consumer guarantees and other legal rights that cannot be excluded, restricted or modified by contract. This Warranty is in addition to and does not affect any of your rights under the Australian Consumer Law and other relevant statutes.
  3. Our goods come with guarantees that cannot be excluded under the Australian Consumer Law. You are entitled to a replacement or refund for a major failure and for compensation of any other reasonably foreseeable loss or damage. You are also entitled to have the goods repaired or replaced if the goods fail to be of acceptable quality and the failure does not amount to a major failure.
  4. Subject to your non-excludable rights under the Australian Consumer Law, ATA expressly excludes any liability for consequential loss, incidental or indirect damages (including but not limited to damages for loss of business profits, business interruption and loss of business information) due to a defect of the NeoSlider™ (Product). In particular any loss or damage caused to other equipment or accessories used with the product or any loss resulting from a delay in repair is excluded to extent permitted by law.
  5. Subject to all of the matters set out below, ATA warrants in relation to the Product that:
    - (a) the Product's drive units will be free of any defects in material and workmanship for at least 24 months after the date of purchase (as evidenced by the sales docket receipt), and
    - (b) the Product's other components and accessories will be free of any defects in material and workmanship for at least 24 months after the date of purchase (as evidenced by the sales docket receipt).
  6. No additional warranty will apply for Products repaired during the relevant warranty period.
  7. For all Products repaired outside the warranty period, a six (6) month warranty that the Product will be free of any defects in material and workmanship will apply from the date of dispatch of the Product to you. ATA may charge you for any repairs undertaken outside the warranty period, and will provide you with a quotation in relation to any such costs for your approval before proceeding with any repairs.
  8. This Warranty applies only where you:
    - (a) immediately notify ATA at the contact details provided in paragraph 1 above or notify the retailer that you purchased the Product from of the alleged defect;
    - (b) return the product to the retailer that you purchased the Product from; and
    - (c) present the relevant sales docket and this Warranty document to the retailer to confirm the date of purchase.
  9. Except for this Warranty, ATA gives no warranties of any kind whatsoever (whether express or implied), in relation to the product, and, subject to paragraph 1 above, all warranties of whatsoever kind relating to the product are hereby excluded.
  10. This Warranty excludes damage resulting from:
    - (a) normal wear and tear;
    - (b) accidental damage;
    - (c) incorrect installation of the Product;
    - (d) blown fuses, electrical surges, power surges or power spikes;
    - (e) theft, fire, flood, rain, water, lightning, storms or any other acts of God;
  - (f) any installation, configuration or use of the Product contrary to the instructions supplied with the Product;
  - (g) the gate used with the Product not being in safe working order and condition;
  - (h) repairs which are not authorised by ATA;
  - (i) any failure to install or maintain the Product in accordance with the instructions supplied with the Product;
  - (j) any use which is not in accordance with the instructions provided with the Product;
  - (k) deliberate or negligent damage to the Product;
  - (l) any unauthorised modification to the Product;
  - (m) faulty or unsuitable wiring in the building in which the Product is installed;
  - (n) damage caused by insects;
  - (o) any cost or expense relating to the recall of the Product;
  - (p) installation of a residential gate opener in a commercial or industrial situation or in a dwelling other than a single-family dwelling;
  - (q) radio or electrical interference; or
  - (r) acts or omissions of any person (including service providers approved by ATA) other than ATA.
11. ATA's liability under this Warranty is limited, at ATA's absolute option, to replacing or repairing the product which ATA, in its unfettered opinion, considers to be defective either in material and/or workmanship or to credit the dealer with the price at which the product was purchased by the dealer.
  12. This Warranty does not extend to cover labour for installation of the Product following repairs, the cost of which must be borne by you.
  13. This Warranty is limited to Return-to-Base (RTB) repair and does not cover labour for on-site attendance, the cost of which must be borne by you.
  14. Except as specified in this Warranty, ATA will not charge you for any repairs or replacements conducted under the Warranty. However, ATA will charge you for any repairs which are not within the scope of this Warranty (or which are not required to be undertaken free of charge pursuant to the Australian Consumer Law).
  15. This Warranty is void if the Product is not returned to the manufacturer in original or suitably secure packaging.
  16. This Warranty is only applicable for repairs to the product carried out within Australia.
  17. This Warranty does not cover consumable items including, without limitation, globes, batteries and fuses.
  18. This Warranty is not transferable.
  19. Where the Product is retailed by any person other than ATA, except for the warranty set out above, such person has no authority from ATA to give any warranty or guarantee on ATA's behalf in addition to the warranty set out above.
  20. Any provision of this Warranty that is prohibited or unenforceable in any jurisdiction is ineffective as to that jurisdiction to the extent of the prohibition or unenforceability. That does not invalidate the remaining provisions of this Warranty nor affect the validity or enforceability of that provision in any other jurisdiction.
  21. Products presented for repair may be replaced by refurbished goods of the same type rather than being repaired. Refurbished parts may be used to repair the Product.

## NOTES:

1. One (1) cycle = one (1) open and one (1) close action of the door or gate.
2. This Warranty is to be read in conjunction with the owner's copy of the installation instruction manual.

© July 2013 Automatic Technology (Australia) Pty Ltd. All rights reserved. TrioCode™, Toro™ and SmartSolar™ are trademarks of Automatic Technology (Australia) Pty Ltd. No part of this document may be reproduced without prior permission. In an ongoing commitment to product quality we reserve the right to change specification without notice. E&OE.

automatic  
TECHNOLOGY

## Automatic Technology (Australia) Pty Ltd

ABN 11 007 125 368

6-8 Fiveways Boulevard  
Keysborough, Victoria, 3173, Australia

P 1300 133 944

E sales@automatictechnology.com.au

www.automatictechnology.com.au

SMART  
SIMPLE  
SECURE