

GDO-12 HiRO

High Rolling Door Opener
Installation Manual

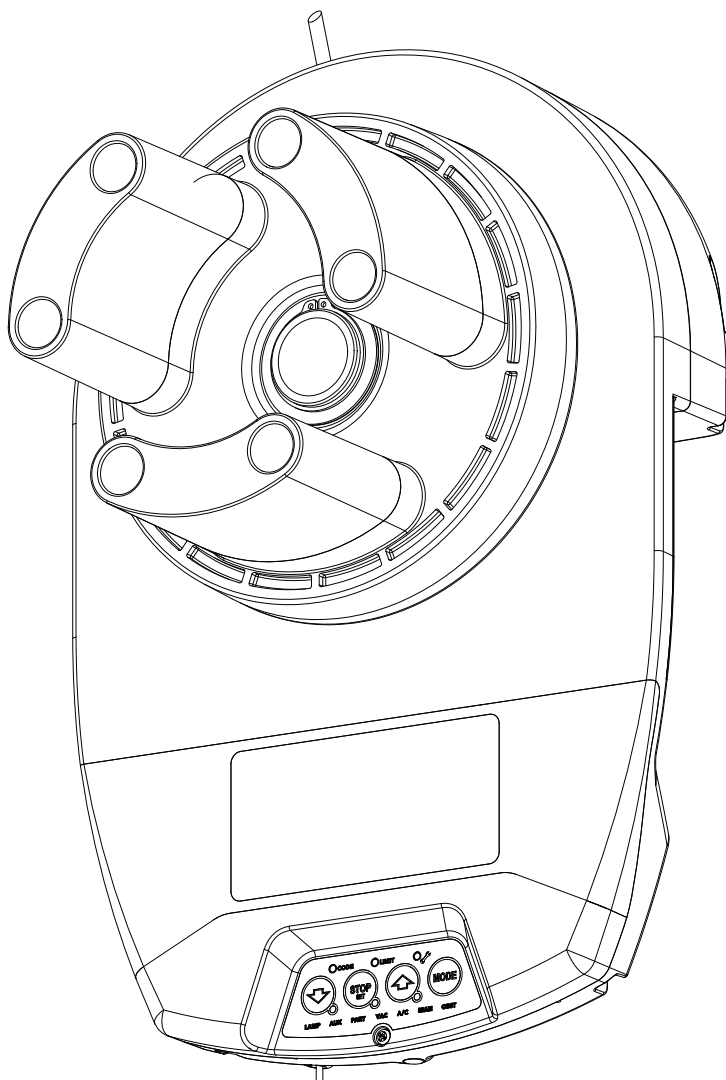



WARNING!: It is vital for the safety of persons to follow all instructions. Failure to comply with the installation instructions and the safety warnings may result in serious personal injury and/or property and remote control opener damage. Please save these instructions for future reference.



ELECTROCUTION!: To reduce the risk of electric shock, this equipment has a grounding type plug that has a third (grounding) pin. This plug will only fit into a grounding type outlet. If the plug does not fit into the outlet, contact a qualified electrician to install the proper outlet. Do not change the plug in any way.

This operator is not equipped for permanent wiring. Contact a qualified electrician to install a suitable receptacle if one is not available.



GDO-12 HiRO

High Roll Up Garage Door Opener

Contents

1. Safety Information	4	7. Operation Instructions	15
2. Specifications	5	7.1 How to Use Your Opener	16
3. Set Up Requirements	6	7.1.1 To Operate the opener:	16
4. Pre-Installation Requirements	7	7.1.2 Replacing the Battery: 3V Lithium Battery CR2032.	16
4.1 Door Operation	7	7.1.3 Battery Disposal	16
4.2 Unsuitable Door Types	7	7.2 User Operating Controls	17
4.3 Position	7	7.3 Door Status Indicators	17
4.4 Power Supply	7	8. Troubleshooting Guide	18
4.5 Sideroom	7	9. After Installation Care	19
4.6 Forks	7	9.1 Service Checklist	19
5. Opener Safety & Security	8	9.2 Warranty	19
5.1 The Door CAN NOT be used by the opener when:	8	10. Appendix	20
5.2 The Door CAN be used when:	8	A - Adjustment Mode Parameters	20
5.3 To Disengage the Opener:	8	B - Setting the PET Mode position	20
5.4 To Re-Engage the Opener:	8	C - LED Status	21
6. Installation Instructions	8	D - Setting Limits via Transmitter	22
6.1 Door Preparation	9	E - Additional Transmitter Functions	23
6.1.1 Preparation	9		
6.1.2 Pinning the Door to the drum:	9		
6.2 Propping the Door	9		
6.3 Fitting the Opener	10		
6.3.1 Mounting The Opener	10		
6.3.2 Fitting Safety Beams	10		
6.3.3 Mounting Base Station to the Opener	10		
6.3.4 Assembling Brackets and Safety Beams	10		
6.4 Setting Limits	11		
6.4.1 Set the Limit Positions and adjust drive speed:	11		
6.4.2 Clearing the Door Limit Positions	11		
6.4.3 Re-profiling the Door	11		
6.5 Auto-Close	12		
6.6 Safety Obstruction Force Test	13		
6.6.1 Testing Close Cycle	13		
6.6.2 Testing Open Cycle	13		
6.7 Coding Transmitter	14		
6.7.1 Transmitter Button to Operate Door	14		
6.7.2 Erasing Programmed Codes	14		
6.7.3 Selecting The Function To Be Coded	14		
6.7.4 Activate Remote Code Set Mode	14		

Automatic Technology Australia Pty Ltd to the extent that such may be lawfully excluded hereby expressly disclaims all conditions or warranties, statutory or otherwise which may be implied by laws as conditions or warranties of purchase of an Automatic Technology Australia Pty Ltd Garage Door Opener. Automatic Technology Australia Pty Ltd hereby further expressly excludes all or any liability for any injury, damage, cost, expense or claim whatsoever suffered by any person as a result whether directly or indirectly from failure to install the Automatic Technology Australia Pty Ltd Garage Door Opener in accordance with these installation instructions.



1. Safety Information

Please read these important safety rules

These safety alert symbols indicate a personal safety or property damage instruction exists. READ THESE INSTRUCTIONS CAREFULLY.

This automatic garage door operator is designed and tested to offer safe service provided it is installed and operated in strict accordance with the following safety rules. Failure to comply with the installation instructions and the safety warnings may result in death, serious personal injury and/or property damage.



WARNING!

- To reduce the risk of injury to persons – Use this operator only with a rolling door. The drive must not be used with a door incorporating a wicket door, unless the drive cannot be operated with the wicket door open.
- This operator is a plug in domestic appliance and is designed for indoor use only. It must be installed in a dry position that is protected from the weather.
- Activate the operator only when the garage door is in full view, free of obstructions and with the operator properly adjusted.
- The network device allows for operation of the door when not in line-of-sight of the door and operator. Therefore the door may operate unexpectedly, therefore do not allow anything to stay in or near the path of the door.
- Watch the moving door and keep people away until the door is completely opened or closed.



BATTERY WARNING!

- This product contains a lithium button/coin cell battery in the transmitters. If a new or used lithium button/coin cell battery is swallowed or enters the body, it can cause severe internal burns and can lead to **DEATH** in as little as 2 hours. Always completely secure the battery compartment. If the battery compartment does not close securely, stop using the product, remove the battery and keep it away from children. If you think batteries might have been swallowed or placed inside any part of the body, **SEEK IMMEDIATE MEDICAL ATTENTION.**



ELECTROCUTION:

- Installation and wiring must be in compliance with your local building and electrical codes.
- This operator is not equipped for permanent wiring. Contact a qualified electrician to install a suitable receptacle if one is not available.
- To reduce the risk of electric shock, this equipment has a grounding type plug that has a third (grounding) pin. This plug will only fit into a grounding type outlet. If the plug does not fit into outlet, contact a qualified electrician to install the proper outlet. Do not change the plug in any way.
- If the power cord is damaged, it must be replaced by the manufacturer, its service agent or a similarly qualified person in order to avoid a hazard.
- Connect the power cord only to properly earthed mains. If an extension lead must be used, make sure it is a 3-core lead and approved to 7 amp capacity.
- This unit is not user serviceable. Unplug the power cord before removing the cover. Ensure that the power cord is attached clear of all moving parts. Ignoring these instructions can cause electric shock.
- Disconnect the power supply when cleaning or other maintenance is being carried out.



CAUTION:

- If your garage has no pedestrian entrance door, an emergency access device should be installed. This accessory allows manual operation of the garage door from outside in case of power failure.
- Frequently examine the installation for imbalance where applicable and signs of wear or damage to springs and mounting. Do not use if repair or adjustment is necessary. Sticking or binding doors must be repaired. Garage doors, door springs, brackets and their hardware are under extreme tension and can cause serious personal injury. Do not attempt any garage door adjustment. Call for professional garage door service.
- Position the Garage Door Operator so that the power plug is accessible when inserted into the power outlet.
- Install the wall transmitter in a location where the garage door is visible, but out of the reach of children at a height of at least 5 feet (1.53m).
- To avoid serious personal injury from entanglement, remove all unnecessary ropes or chains and disable any equipment such as locks which are not needed for powered operation.
- Do not wear rings, watches or loose clothing while installing or servicing a garage door operator.
- Ensure ladder is the correct type for the job and is on flat ground. We recommend the user has 3 points of contact while on ladder.
- Activate the operator only when the garage door is in full view, free of obstructions and with the operator properly adjusted.
- The operator is not intended for use by young children or infirm persons without supervision.
- Keep transmitters away from children.
- Do not allow children to play with door controls

2. Specifications

Technical Specifications	GDO-12V2
Rated voltage range	230V - 240V
Rated frequency	50Hz / 60Hz
Rated power input	200W
Rated operating time:	6 min
Rated operating temperature	-10 °C to +55 °C
Rated load	500N
Maximum turns of door drum: Max door weight: Maximum door area (wind-lock): Maximum door area:	6 turns of the drum wheel 270kg * 22m ² ** 28m ²
Door must be well balanced and able to be operated by hand, as per warranty conditions and standard AS/NZS 4505:2012	
Minimum sideroom	35mm
IP rating	IP20
Receiver type	Multi-frequency UHF FM (433.47, 433.92 & 434.37MHz)
Receiver code storage capacity	64 x 4-button Transmitters
Number of code combinations	Over 100 billion random codes
Transmitter battery	CR2032 (3 Volts)
Courtesy light	LED (Light Emitting Diodes)

*: Gross door weight, incl. all fittings

**: Windy conditions can activate the obstruction feature of the opener.



3. Set Up Requirements

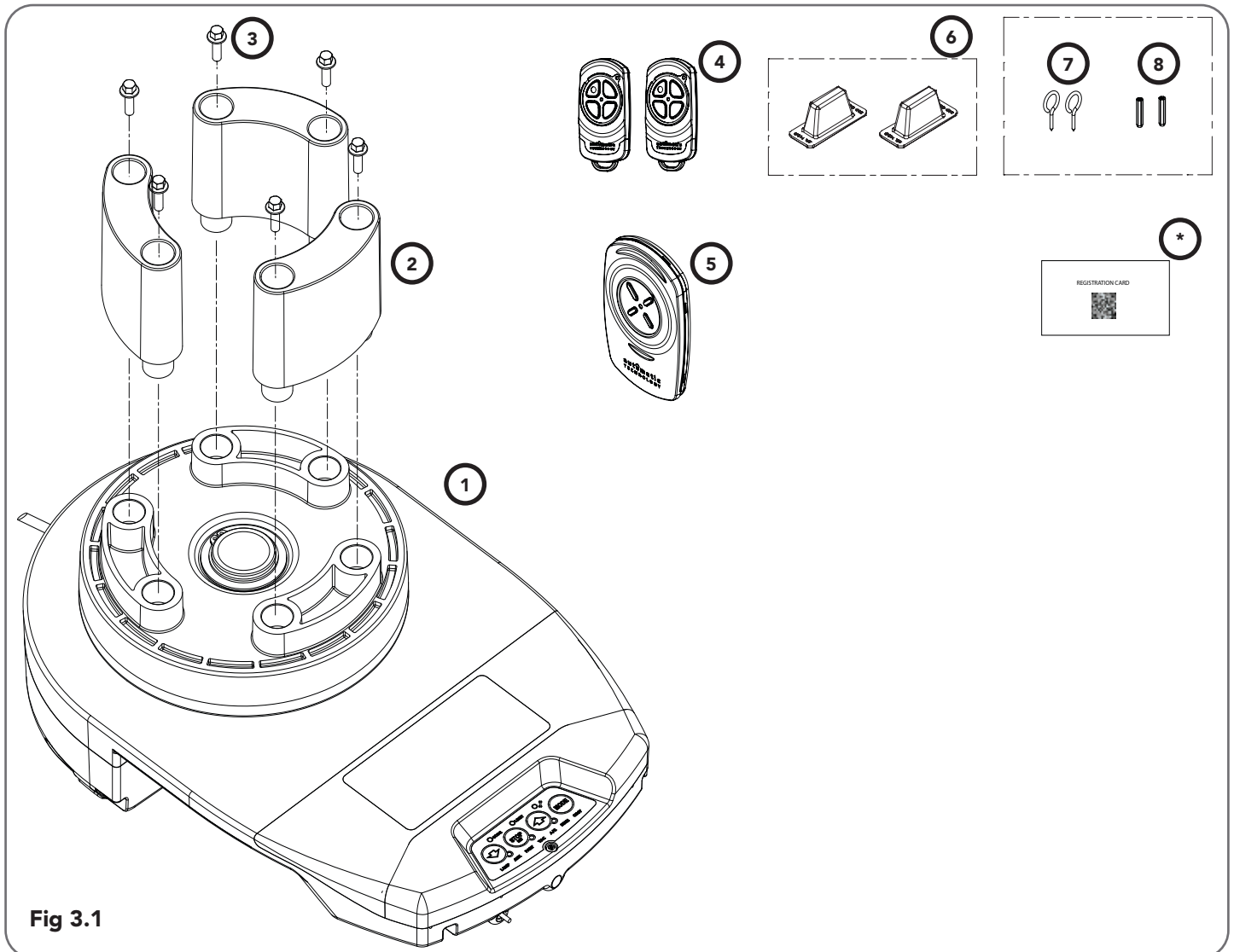

Fig 3.1

3.1 Kit Contents

ITEM	DESCRIPTION	QTY
1	GDO-12 POWER DRIVE UNIT	1
2	INTERNAL GEAR ADAPTER (FORKS)	3
3	HEX SERRATION HEAD SCREW M6 X 20	6
4	4 BUTTON TRANSMITTERS	2
5	4 BUTTON WALL TRANSMITTER	1
6	LOCKING BAR COVERS	2
GUIDE PACK VR12		
7	SCREW-EYE	2
8	PLASTIC WALL PLUG 6.9 X 25 (1")	2

* **REGISTRATION CARD (Please retain for optional smart phone control kit)**



4. Pre-Installation Requirements



IMPORTANT SAFETY INSTRUCTIONS FOR INSTALLATION
Warning: Incorrect installation can lead to severe injury.
Follow ALL installation instructions.

NOTE: Planetary chain equipment must be removed from the door prior to installation of GDO-12V1 HiRo™.

4.1 Door Operation

The door must be in good operating condition. The maximum effort to move the door up or down, from stationary, should not exceed 200 Newtons (20 kg force) at the bottom rail.

Lift the door to about halfway. When released, the door should stay in place supported entirely by its springs. Raise and lower the door to check for binding or sticking.

The door may need to be serviced to meet these requirements – refer to the door manufacturer's servicing instructions or contact an authorised dealer.

4.2 Unsuitable Door Types

The fitting of an opener to doors with removable mullions or doors incorporating a wicket door is not recommended (**Fig. 4.1**).

4.3 Position

The opener can be installed on either the right or left hand side of the door (when viewed from inside the garage). The opener is factory set for right hand side installation.

This opener must be installed in a dry position that is protected from the weather. Moisture or corrosion damage is not covered by the Warranty

Check that the temperature range marked on the drive unit is suitable for the location.

4.4 Power Supply

Properly earthed 3 pin single-phase power is required.



WARNING! Using a portable power generator is not recommended. The opener may appear to malfunction due to spikes, surges and fluctuations in the generated voltage.

4.5 Sideroom

The minimum sideroom required from the edge of the door curtain is 35 mm to the inside of the door bracket, and 80mm to the wall. If the Battery Backup is to be fitted, at least 130mm to the bracket is required.

Therefore the recommended sideroom from the edge of the door curtain is 130mm to the inside of the door bracket, and 170mm to the wall as per diagram. (**Fig. 4.2**). Please refer to **Fig 4.3** for Windlock Doors.

NOTE: The door axle diameter must not exceed 35mm.

4.6 Forks

Attach and secure the three (3) forks (2) with the six (6) hex serration head screws (3) to the drive unit (1) (**Fig. 3.1**). All forks must be used and properly engaged into the drum of the door for the opener to work effectively.



Fig 4.1

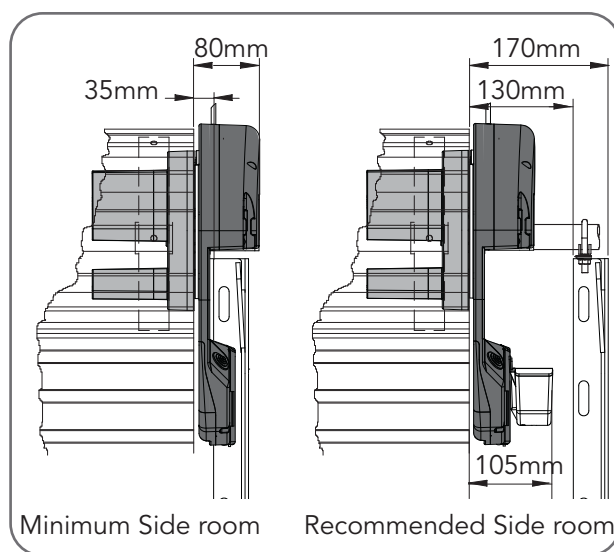

Fig 4.2

Standard Roller Doors

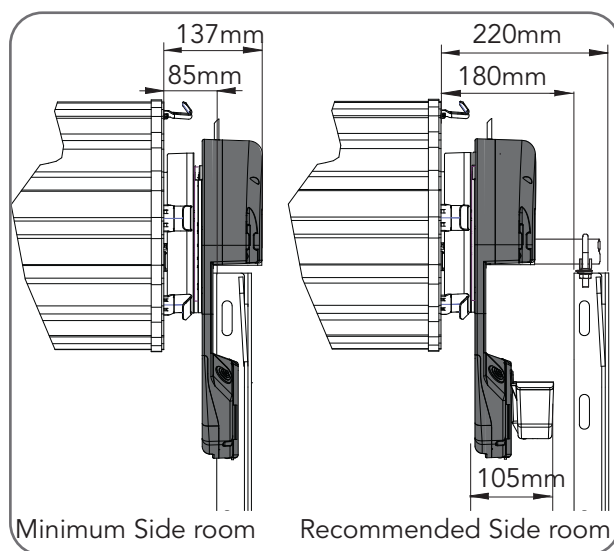

Fig 4.3

Windlock Roller Doors

5. Opener Safety & Security

5.1 The Door CAN NOT be used by the opener when:

- There is a locking device installed.
- There is a power failure.

5.2 The Door CAN be used when:

- There is an emergency, by disengaging the opener.
- There is a power failure, by disengaging the opener.

5.3 To Disengage the Opener:

- It is recommended to do so with the door in the closed position.
- Pull down on the manual release cord, until you hear a click.
- Move the door manually.

 **CAUTION:** When the opener is manually disengaged, the door is no longer locked. To lock the door manually, re-engage the opener after the door is closed.

5.4 To Re-Engage the Opener:

- Check the door has not been locked by a locking device.
- Pull down on the manual release cord, until you hear a click.
- The door will now operate from the opener.

 **WARNING!** Please test the manual release mechanism to ensure that the manual release is easy to operate. No more than 20 kg of force should be required to disengage the door using the manual release cord. If excessive force is required reset the close limit position (Section 6.4.3 Resetting Door Limit Positions).

MANUAL RELEASE 



WARNING! When operating the manual release (while the door is open) the door may fall rapidly due to weak or broken springs, or due to being improperly balanced.
Do not disengage the operator to manual operation with children/persons or any objects including motor vehicles within the doorway.

IN THE EVENT THE DOOR BECOMES OBSTRUCTED
DETACH DOOR FROM OPENER AS FOLLOWS:

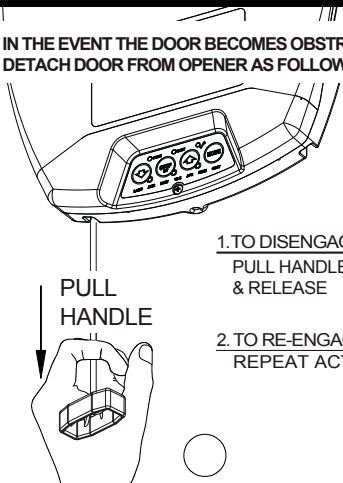

PULL
HANDLE

1. TO DISENGAGE:
PULL HANDLE DOWN
& RELEASE

2. TO RE-ENGAGE:
REPEAT ACTION



 **WARNING!** DO NOT remove the manual release label from the cord.

6. Installation Instructions

IMPORTANT INSTALLATION INSTRUCTIONS.

WARNING - To reduce the risk of severe injury or death:

- READ AND FOLLOW ALL INSTALLATION INSTRUCTIONS.
- Install only on a properly operating and balanced garage door. An improperly balanced door has the potential to inflict severe injury. Have a qualified service person make repairs to cables, spring assemblies, and other hardware before installing the opener.
- Remove all pull ropes and remove or make inoperative, all locks connected to the garage door before installing opener.
- Where possible, install the door opener 2.14m or more above the floor. For products having an emergency release, mount the emergency release 1.83 above the floor and avoiding contact with vehicles to avoid accidental release.
- Do NOT connect the opener door operator to source of power until instructed to do so.
- Check the temperature range marked on the drive unit is suitable for the location.
- Locate the control button:
 - within sight of door,
 - at a minimum height of 1.53m above floors, landings, steps or any other adjacent walking surface so small children are not able to reach it, and
 - away from all moving parts of the door.
- Install the Entrapment Warning Label next to the control button in a prominent location. Install the Emergency Release Label. Attach the marking on or next to the emergency release.
- After installing the opener, the door must reverse within 2 seconds when it contacts a 1 1/2-inch high object (or a 2 by 4 board laid flat) on the floor. Ensure that the mechanism is properly adjusted and the protection system and manual release function correctly.
- For products having a manual release, instruct the end user on the operation of the manual release. Exception: For horizontally sliding doors, Item 2 shall be replaced with "Have a qualified service person make repairs and hardware adjustments before installing the opener. DO NOT remove the manual release label from the cord.

6.1 Door Preparation

6.1.1 Preparation

- a. Check the door's operation:
 - i. The door must travel smoothly and be easy to operate by hand.
 - ii. Adjust any tight or twisted guides.
 - iii. Clean the guides if there is any oil or wax present using a suitable white spirit. The only lubricant suitable for use on door guides is silicon spray. DO NOT use WD-40, RP-7, petroleum grease, or similar.
 - b. Install the locking bar covers (6) if there are locking bar holes in the guides.
 - c. Affix the warning labels supplied with this opener in a prominent place where they are clearly visible.
 - d. Choose the side where the opener will be installed ensuring there is sufficient sideroom.
- Check that the door is still balanced and smooth to operate. If it is not, the door may require servicing (refer to door manufacturer's instructions).

6.1.2 Pinning the Door to the drum:

Pinning the door's curtain to its drum maintains security when the opener is closed. If the curtain is not pinned the door can be partially opened manually.

- a. Fully close the door.
- b. Mark a minimum of two (2) drill holes on the drum to each end of the door.
- c. Drill holes using 3.2mm (1/8") drill bit.
- d. Fit M10 x 32mm screws and washers (not supplied) to each of the four (4) holes. This screw should be positioned as low as possible in the groove, but make sure that it does not alter the curtain's normal lead in to the guide.

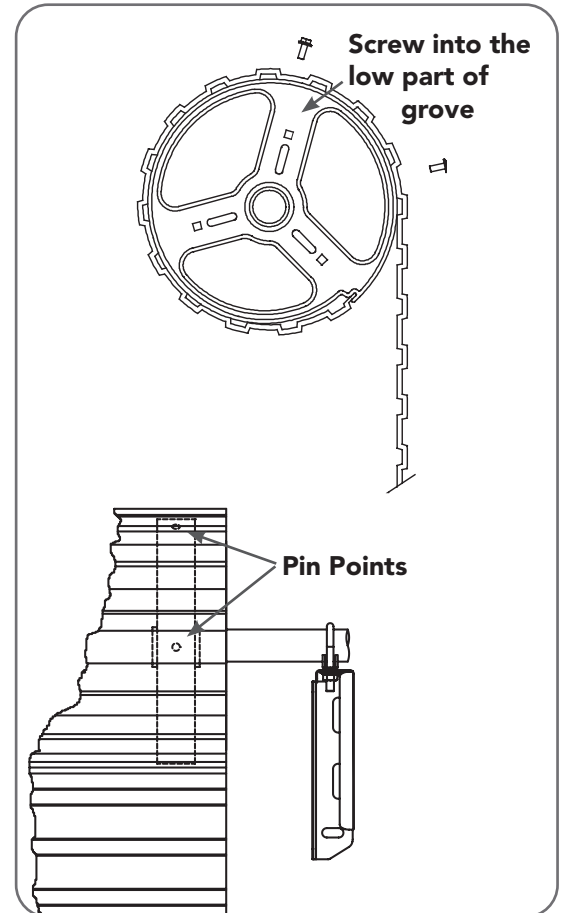
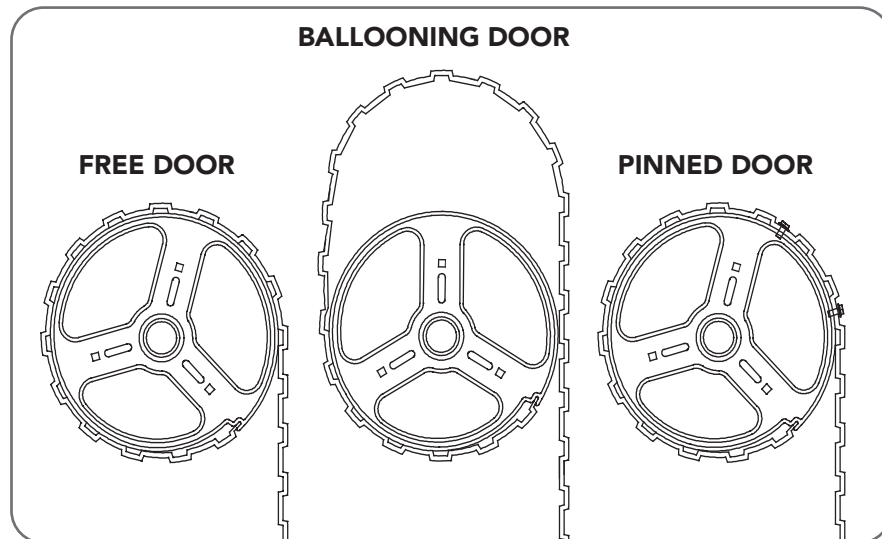

6.2 Propping the Door

6.2.1 Door prop preparation

- a. At the end opposite to where the opener will be fitted, check that each nut securing the door axle, is tightened (to a torque setting of 40Nm) to the bracket. **(Fig. 6.2)**
- b. Open the door completely and tie safety ropes around the door roll approximately 300 mm from each end. Do not tie the ropes too tight as damage to the curtain may ensue.
- c. At the end where the opener is to be fitted, support the door with a safe and suitable lifter.

WARNING! Make sure the door is secure in the support, is stable and will not move.

- d. At the end where the opener will be fitted, use pen to mark the position of the saddle on the door bracket and the position of the door bracket on the wall to assist in reassembling.
- e. Remove the bolts and saddle from the door bracket.
- f. Raise the door off the door bracket and secure in the support.

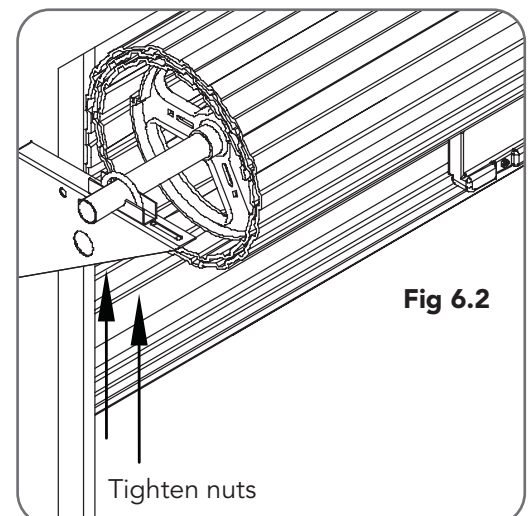

NOTE - For minimum sideroom installations, the door may have to be taken down.

6.3 Fitting the Opener

6.3.1 Mounting The Opener

- Check the drive gear rotates freely, by pulling the string handle down (there will be a click) to disengage opener. Then move the forks from side to side by hand
- Slide the opener over the door axle and into the drum of the door (**Fig. 6.3**).
- Ensure the internal gear is pushed in as far as possible (without interfering with the door curtain) and that the door drum's wheel spokes are completely between the opener's drive forks.
- Evenly tighten the supplied nuts on the clamp assembly of the opener to a torque setting of 40Nm.
- Remove the safety rope and door stand or prop.
- Connect the power cord to a suitable powerpoint, but **DO NOT** switch on.
- Secure the power cord away from any moving object (e.g the door) with the cable clip supplied.
- With the opener still disengaged, pull the door up and down to make sure it runs freely.

NOTE - If the manual release handle is more than 1.8 metres from floor level when the opener is installed, extend the handle to a height less than 1.8 metres.

6.3.2 Fitting Safety Beams

The Safety Beam Kit provides additional safety by preventing the door closing when the beam is blocked by a car, child etc. When the Safety Beam Kit is installed the Auto-close feature can be enabled if required.

WARNING! The Opener must be fitted with Safety Beams if:

- the closing force at the bottom edge of the door exceeds 400N (40kg) and/or;
- the opener has a smart device fitted to operate the door, when not in line-of-sight.

The transmitter and receiver need to be placed in line of sight, with the beam 100mm above the ground level (as per AS/NZS 60335-2-95:2012 Amendment 2:2018). This can be achieved by ensuring the bottom of the receiver and transmitter are 65mm above ground level. They should also be placed as close as possible to the door opening with the receiver (RX) in shade and the transmitter (TX) in sun or shade (**Fig. 6.4**).

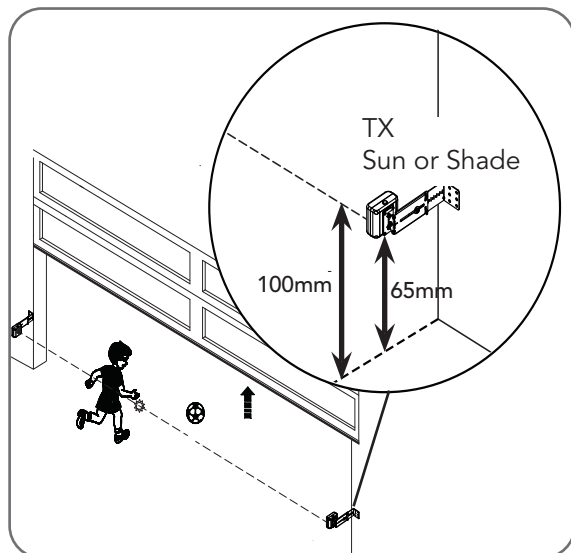

Fig 6.4

6.3.3 Mounting Base Station to the Opener

- Remove the light diffuser cover via screw at the bottom.
- Mount the base station board next to the control board as shown using the screw supplied.
- Plug the harness into the 4 pin connector on the base station board and connect the harness to the ACC pin on the control board.
- Refit the light diffuser.

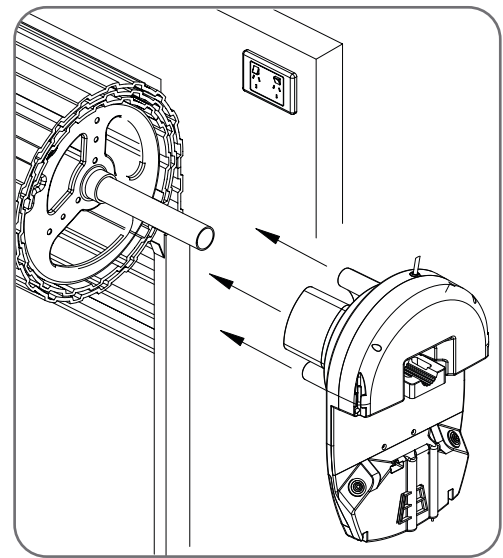

Fig 6.3



WARNING!

- The opener must not be used with a door incorporating a wicket door.
- The doors axle must be securely clamped otherwise the door can loose spring tension.
- The door and its springs are under significant tension. Adjustments should only be carried out by experienced persons, as this function can be dangerous if not performed under strict safety procedures.

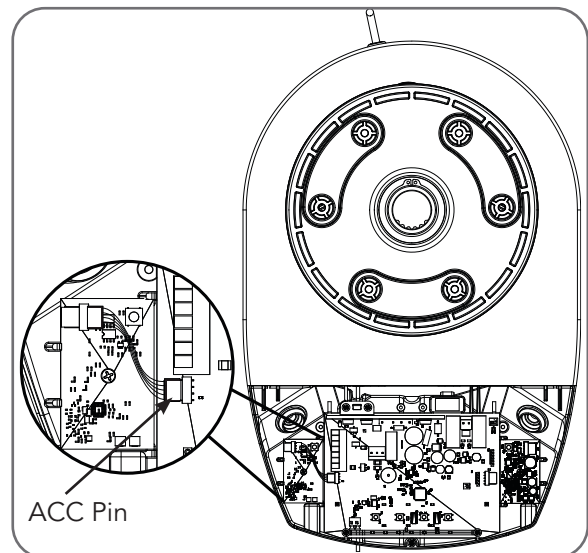

Fig 6.5

6.3.4 Assembling Brackets and Safety Beams

Refer to the Safety Beam installation manual inside the kit for mounting, wiring diagrams, battery installation and how to connect the specific safety beam.



CAUTION! The Safety Beam must be installed and connected before the travel limits are set.

6.4 Setting Limits

6.4.1 Set the Limit Positions and adjust drive speed:

The Limit Positions can vary due to site conditions, such as uneven ground. When setting the Close limit, ensure the position is when the door makes first contact with the ground. Alternatively for the Open limit the position should be at the height of the garage opening.

NOTE: The drive speed is set to the fastest setting by default. This may not be suitable for larger doors.

- Move the door to the half way position.
- Engage the opener by pulling down on the manual release string until a click sounds.
- Switch power on and the BLUE LED on the BLUE CLOSE button will start to flash.

CLOSE limit:

- Press and hold the CLOSE button to start closing the door, taking note of the speed the door moves.



HELPFUL TIP: If the door moves in opposite direction, press and hold the OPEN and CLOSE buttons at the same time (approx 3 seconds) until you hear a beep. This will reverse the direction of the motor.

- If the close speed is not suitable, to make a change, press and hold the CLOSE button and by pressing the RED STOP / SET button on the opener it will cycle through all three speed modes as shown in table. **Fig 6.4**
- Once at the desired speed, release the CLOSE button.
- To set the close limit, inch the door by making single presses of the CLOSE button to the desired position. We recommend the CLOSE limit position being the first point of contact of the rubber strip (at the bottom of the door) with the ground.
- If the door overshoots, press the OPEN button to move the door in the OPEN direction.

WARNING! In setting the close limit position, do not force the door into the floor with excessive force, as this can interfere with the ease of operation of the manual release mechanism.

- When the door is at the desired CLOSE position, press the STOP / SET button on the opener, the GREEN LED on the OPEN button will now flash.

OPEN limit:

- Press and hold the OPEN button to start opening the door, taking note of the speed the door moves.
- If the open speed is not suitable, to make a change, press and hold the OPEN button and by pressing the STOP / SET button on the opener it will cycle through all three speed modes as shown in table.
- Once at the desired speed, release the OPEN button.
- Continue inching the door to the desired position.
- To set the open limit, inch the door by making single presses of the OPEN button to the desired position. We recommend the OPEN limit position being the height of the garage opening.
- If the door overshoots, press the CLOSE button to move the door in the CLOSE direction.

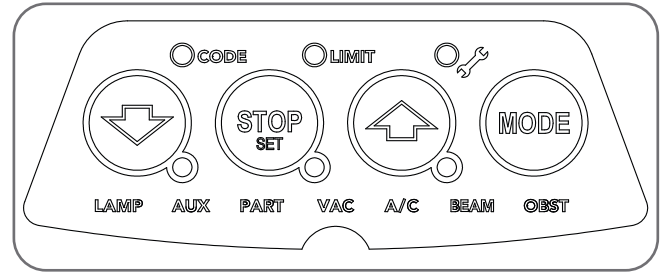

Door Opener Speed Mode	STATUS	BEEP
Fast (Default)	On	3 Beeps
Medium	On	2 Beeps
Slow	On	1 Beeps

Fig 6.4

WARNING! The door will automatically close, open and close again after the next step. Ensure that nothing is in the door's path.

- When the door is at the desired OPEN position, press the STOP / SET button. The door will now automatically close and open to calculate the safety obstruction settings.

NOTE: If unhappy with the speed or travel limit setting, restart this procedure by clearing the door limit positions as per below first.

6.4.2 Clearing the Door Limit Positions

Limit positions can be deleted by:

- Switching off power to the unit.
- Pressing and holding the RED STOP / SET button and switching power on to the unit will clear the settings memory. (the LIMIT LED will flash).
- Follow from CLOSE limit: above to set new limit positions.



HELPFUL TIP: Alternatively set travel limits using a transmitter, allowing free movement around the garage to better assess the desired limit positions. See Appendix D.



HELPFUL TIP: The door can be set to a partial open position and programmed to a transmitter button. Refer to Appendix B.

6.4.3 Re-profiling the Door

Re-profiling is a simplified way of re-learning the travel characteristic of a previously setup Limit Switch travel installation. Re-profiling can be used when the travel characteristics of the door change due to mechanical adjustments etc. To initiate a re-profile:

- Limits must be set.
- Press the MODE button repetitively until the LIMIT LED is lit.
- One of the word LEDs (LAMP etc) will highlight. Press the BLUE CLOSE button to move to OBST
- Press and hold the STOP / SET button for two seconds, the door will open and close by itself to record profile.



6.5 Auto-Close

Auto-Close mode is a function that automatically closes the door after a pre-set time. Safety beams must be installed in order to run the Auto-Close function. There are two types of Auto-Close available:

- (i) Standard auto-close - the door will Auto-Close after a programmed time. In this mode the timer starts to countdown as soon as the door is fully open. This function is useful in case the safety beam does not get triggered.
- (ii) Safety Beam triggered auto-close - the door will auto-close after a programmed time. In this mode the timer starts counting down only when the safety beam is triggered. ie car leaving the garage.

To enable the Auto-Close function:

- a. Press and release the MODE button until the Spanner LED is highlighted.
- b. One of the word LEDs (LAMP etc) will highlight. Press the BLUE CLOSE button to move to the particular parameter:
 - (i) two (2) times to get to PE A/C or
 - (ii) three (3) times to get to standard A/C.
- c. Press RED STOP / SET button to enter A/C parameter.
- d. The OPEN, STOP and CLOSE LEDs will now flash. The default setting for Auto-Close is OFF.
- e. Press the OPEN button to move through options.
- f. Press the RED STOP / SET button to save the parameter's new value or press MODE to leave the value unchanged - flashing will stop.

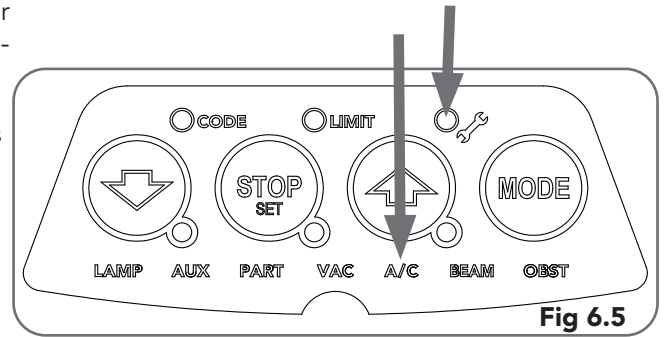

Fig 6.5

WARNING! It is compulsory to have Safety Beams installed when using Auto-Close mode.

LED Indicators	Parameter	OPEN	OPEN & STOP	STOP	CLOSE & STOP	CLOSE
A/C LED	A/C Function	90s	60s	30s	15s	OFF
A/C & BEAM LED'S	P.E A/C Function	60s	30s	15s	5s	OFF



6.6 Safety Obstruction Force Test

WARNING! Take care when testing or adjusting the Safety Obstruction Force. Excessive force may cause **SERIOUS PERSONAL INJURY** and/or **PROPERTY DAMAGE**.

WARNING! If the door fails these tests, put the opener into manual mode, only operate the door by hand and call for service.

6.6.1 Testing Close Cycle

- Press the OPEN button to open the door.
- Place a piece of timber approximately 40mm high on the floor directly under the door (**Fig. 6.6.1**).
- Press the CLOSE button to close the door. The door should strike the object and start to re-open.

6.6.2 Testing Open Cycle

- Press the CLOSE button to close the door.
- Press the OPEN button to open the door. When the door reaches the half open point, grab the bottom rail of the door firmly and the door should stop.
- If the door does not reverse readily when closing, or stop when opening, the force may be excessive and need adjusting.

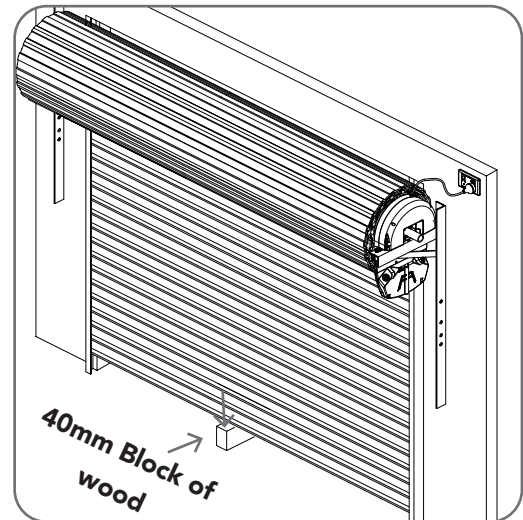

Fig 6.6

WARNING! Safety beams must be installed if the closing force at the bottom edge of the door exceeds 400N (40kg).

TRANSMITTERS COMPLIANCE STATEMENT

TRANSMITTERS COMPLY WITH ALL UNITED STATES AND CANADIAN LEGAL REQUIREMENTS AS OF THE DATE OF MANUFACTURE. TO COMPLY WITH FCC PART 15 AND OR RSS 210 OF INDUSTRY CANADA (IC) RULES, ADJUSTMENT OR MODIFICATIONS OF THIS RECEIVER AND / OR TRANSMITTER ARE PROHIBITED, EXCEPT FOR CHANGING THE CODE SETTING OR REPLACING THE BATTERY. THERE ARE NO OTHER USER SERVICEABLE PARTS. TESTED TO COMPLY WITH FCC STANDARD FOR HOME OR OFFICE USE. OPERATION IS SUBJECT TO THE FOLLOWING TWO CONDITIONS:

- (1) THIS DEVICE MAY NOT CAUSE HARMFUL INTERFERENCE, AND
- (2) THIS DEVICE MUST ACCEPT ANY INTERFERENCE RECEIVED, INCLUDING INTERFERENCE THAT MAY CAUSE UNDESIRED OPERATION.

NOTE: THIS EQUIPMENT HAS BEEN TESTED AND FOUND TO COMPLY WITH THE LIMITS FOR A CLASS B DIGITAL DEVICE, PURSUANT TO PART 15 OF THE FCC RULES. THESE LIMITS ARE DESIGNED TO PROVIDE REASONABLE PROTECTION AGAINST HARMFUL INTERFERENCE IN A RESIDENTIAL INSTALLATION. THIS EQUIPMENT GENERATES, USES AND CAN RADIATE RADIO FREQUENCY ENERGY AND, IF NOT INSTALLED AND USED IN ACCORDANCE WITH THE INSTRUCTIONS, MAY CAUSE HARMFUL INTERFERENCE TO RADIO COMMUNICATIONS. HOWEVER, THERE IS NO GUARANTEE THAT INTERFERENCE WILL NOT OCCUR IN A PARTICULAR INSTALLATION. IF THIS EQUIPMENT DOES CAUSE HARMFUL INTERFERENCE TO RADIO OR TELEVISION RECEPTION, WHICH CAN BE DETERMINED BY TURNING THE EQUIPMENT OFF AND ON, THE USER IS ENCOURAGED TO TRY TO CORRECT THE INTERFERENCE BY ONE OR MORE OF THE FOLLOWING MEASURES:

REORIENT OR RELOCATE THE RECEIVING ANTENNA

INCREASE THE SEPARATION BETWEEN THE EQUIPMENT AND RECEIVER

CONNECT THE EQUIPMENT INTO AN OUTLET ON A CIRCUIT DIFFERENT FROM THAT TO WHICH THE RECEIVER IS CONNECTED.

CONSULT YOUR LOCAL DEALER OR AN EXPERIENCED RADIO/TV TECHNICIAN FOR HELP.



6.7 Coding Transmitter

6.7.1 Transmitter Button to Operate Door

The **GDO-12 HiRo™** can store up to sixty four (64) transmitters in its memory.

- Press the MODE button to highlight the CODE LED.
- Press OPEN or CLOSE button until BLUE CLOSE, RED STOP/SET and GREEN OPEN LEDs are on.
- Press and hold the STOP / SET button to enter the code set procedure (**Fig. 6.7.1**).
- Press the transmitter button you wish to use to operate the door opener (e.g. button 1) and hold for 2 seconds then release.
- Press the same transmitter button again and hold for seconds, then release.
- Release the STOP / SET button.



HELPFUL TIP: Refer to Appendix for Additional Transmitter coding functions

6.7.2 Erasing Programmed Codes

If the GREEN OPEN button is held down on power up it will clear the the transmitter memory. (As the button is being held the CODE LED will flash).

If a transmitter is already coded into the opener, additional transmitters can be coded without being in direct contact with the opener's wall console unit.

NOTE: Only the function of the existing transmitter button can be assigned to new transmitter. Please read instructions prior to proceeding - there is a time-out facility for security reasons.

6.7.3 Selecting The Function To Be Coded

- Using the existing transmitter, operate the Door with the transmitter button which has the function to be coded (e.g. Button 1 has been coded with the OSC function assigned).
- If the button's function activates the Door (PART, OSC, CLS, STP or OPN) wait for the Door to complete its cycle.

6.7.4 Activate Remote Code Set Mode

- Use a small pin / pen to press and hold through the Coding Hole of the existing transmitter for 2 seconds (**Fig. 6.7.2**).
- Within 10 seconds, press the button on the new transmitter you wish to code for 2 seconds.
- Press the same button again (within 10 seconds) for confirmation.
- Test Operation. The new transmitter button should now function as the existing transmitter.

NOTE: To code other buttons from an existing transmitter, repeat process pressing the button your wish to replicate.

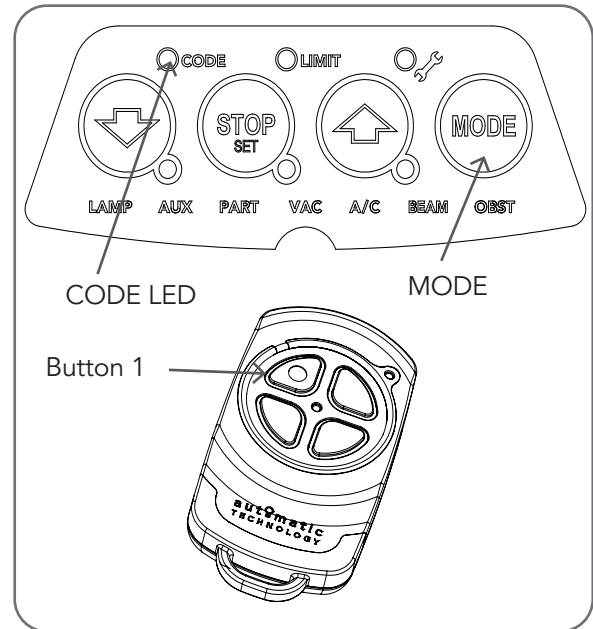

Fig 6.7.1

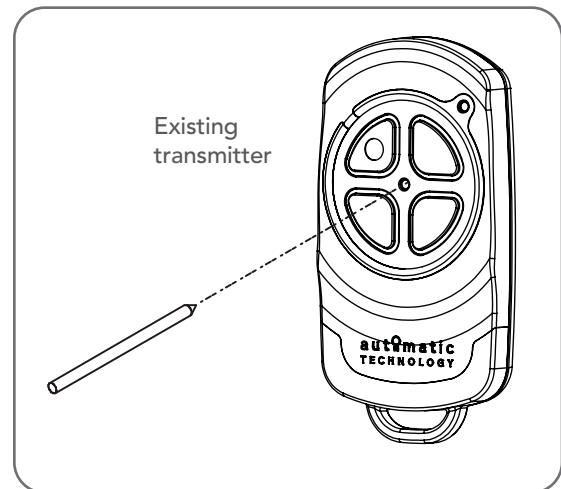

Fig 6.7.2



7. Operation Instructions

IMPORTANT SAFETY INSTRUCTIONS

WARNING! TO REDUCE THE RISK OF SEVERE INJURY OR DEATH:

(1) READ AND FOLLOW ALL INSTALLATION INSTRUCTIONS.

(2) NEVER LET CHILDREN OPERATE OR PLAY WITH DOOR CONTROLS. KEEP THE REMOTE CONTROL AWAY FROM CHILDREN.

(3) ALWAYS KEEP THE MOVING DOOR IN SIGHT AND AWAY FROM PEOPLE AND OBJECTS UNTIL IT IS COMPLETELY CLOSED. NO ONE SHOULD CROSS THE PATH OF THE MOVING DOOR.

(4) NEVER GO UNDER A STOPPED, PARTIALLY OPEN DOOR.

(5) TEST DOOR OPENER MONTHLY. THE GARAGE DOOR **MUST** REVERSE ON CONTACT WITH A 1-1/2-INCH HIGH OBJECT (OR A 2 BY 4 BOARD LAID FLAT) ON THE FLOOR. AFTER ADJUSTING EITHER THE FORCE OR THE LIMIT OF TRAVEL, RETEST THE DOOR OPENER. FAILURE TO ADJUST THE OPENER PROPERLY INCREASES THE RISK OF SEVERE INJURY OR DEATH.

(6) FOR PRODUCTS HAVING AN EMERGENCY RELEASE, WHEN POSSIBLE, USE THE EMERGENCY RELEASE ONLY WHEN THE DOOR IS CLOSED. USE CAUTION WHEN USING THIS RELEASE WITH THE DOOR OPEN. WEAK OR BROKEN SPRINGS ARE CAPABLE OF INCREASING THE RATE OF DOOR CLOSURE AND INCREASING THE RISK OF SEVERE INJURY OR DEATH.

(7) KEEP GARAGE DOORS PROPERLY BALANCED. SEE OWNER'S MANUAL. AN IMPROPERLY BALANCED DOOR INCREASES THE RISK OF SEVERE INJURY OR DEATH. HAVE A QUALIFIED SERVICE PERSON MAKE REPAIRS TO CABLES, SPRING ASSEMBLIES, AND OTHER HARDWARE.

(8) EXCEPT FOR MODEL AM800, THIS OPERATOR SYSTEM IS EQUIPPED WITH AN UNATTENDED OPERATION FEATURE. THE DOOR COULD MOVE UNEXPECTEDLY. **NO ONE SHOULD CROSS THE PATH OF THE MOVING DOOR.**

(9) SAVE THESE INSTRUCTIONS.



7.1 How to Use Your Opener

For maximum efficiency of your operator, your garage door must be in good operating condition. An annual service of your garage door by door professional is recommended.

7.1.1 To Operate the opener:

- Press the programmed transmitter button until your door begins to move (usually 2 seconds). Make sure you can see the door when you use the transmitter (**Fig 7.1.1**).
- If you are in a vehicle you should aim the transmitter through your windscreen as shown.
- Check that the door is fully open or closed before you drive in or away.
- If you press the transmitter whilst the door is moving the door will stop. The next press of the transmitter will move the door in the opposite direction.

7.1.2 Replacing the Battery: 3V Lithium Battery CR2032.

- To test the battery is working, press and hold a transmitter button. Check Light Status table to determine if battery needs replacing

Light Status	Battery Status
Solid	OK
Flashing	Requires replacement
No light	Requires replacement

- Remove screw from back of cover.
- Use screw driver to separate the transmitter casing to expose circuit board.
- Use a non-metallic object (e.g. pen) to remove the battery. (**Fig. 7.1.2**).

7.1.3 Battery Disposal

When batteries reach the end of their usual life in accordance with Australian Battery Recycling Initiative please follow the next simple steps for protecting the environment.

WARNING! The Battery shall be disposed of properly, including keeping them away from children. Even used batteries may cause injury.

DO NOT throw the batteries in municipal waste. This symbol of the crossed out wheeled bin indicates that the battery should not be placed in the municipal waste. Check your local regulations for appropriate disposal of the batteries.

Recycling all batteries will have other environmental and social benefits:

- Some batteries are less toxic but hazardous for other reasons. Lithium batteries can explode or catch fire in landfill, while button cells are dangerous if swallowed by children. Recycling offers a safe and environmentally responsible solution for end of life batteries.
- Battery recycling recovers non-renewable materials such as lead, cadmium, steel, zinc, manganese, cobalt, silver, plastics and rare earth elements.
- Removal of batteries and other hazardous household products from household waste facilitates the recovery of organic materials through alternative waste technologies such as composting. Batteries and heavy metals are known contaminants in compost.
- The community supports recycling because it reduces waste to landfill and achieves environmental benefits.

WARNING! Prior to disposal, recycling, or collection, all battery terminals must be securely insulated with a non conductive material to prevent any two batteries from short circuiting and generating heat during storage or transport. Battery terminals may be insulated with electrical tape; or batteries may be individually packaged in a non conductive material (e.g., plastic bag or original packaging).

CAUTION: Activate the operator only when the door is in full view, free of obstructions and with the operator properly adjusted. No one should enter or leave the garage while the door is in motion. Do not allow children to play near the door.

WARNING! This operator has a grounding type plug and there are no user serviceable parts inside this operator.

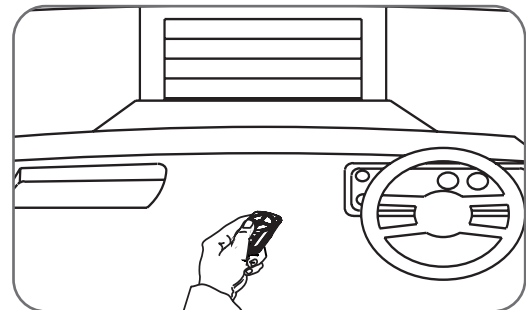

Fig.7.1.1

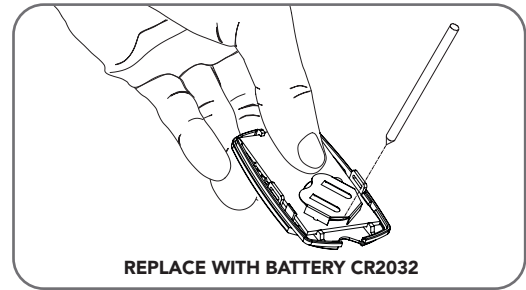
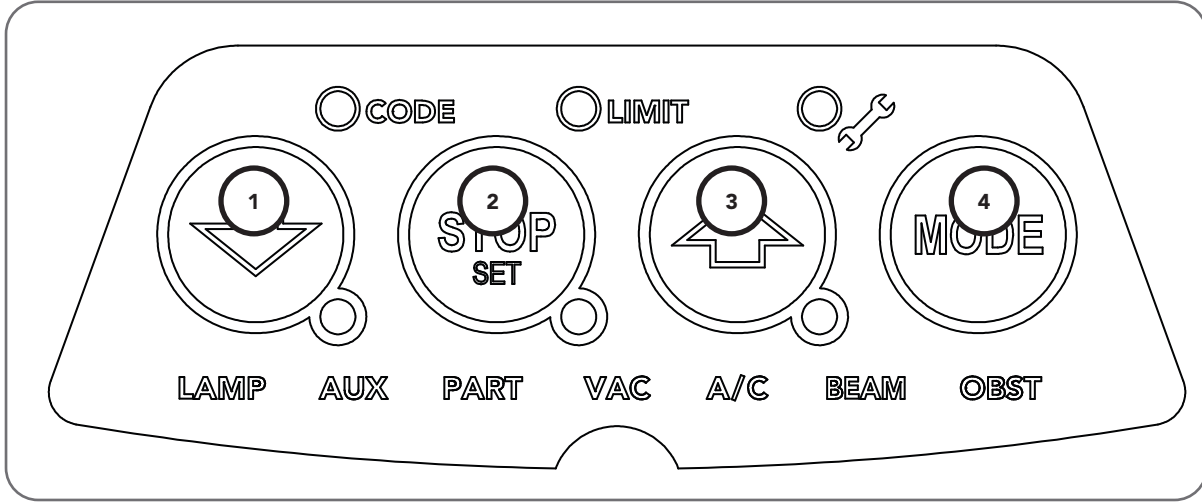

Fig.7.1.2

WARNING! Chemical Burn Hazard. Keep batteries away from children

7.2 User Operating Controls



Button	Function
1. BLUE DOWN ARROW	Close Button
2. RED STOP/SET	Stop / Set Button
3. GREEN UP ARROW	Open Button
4. MODE	Mode Selection Button

7.3 Door Status Indicators

Door Status Indicators	OPEN LED (green)	CLOSE LED (blue)	STOP (red)
Open	On		
Close		On	
Opening	Flashing		
Closing		Flashing	
Door travel stopped	Flashing	Flashing	Flashing
Door obstructed when opening	Flashing		On and door will stop
Door obstructed when closing		Flashing	Beeps while door is moving
Opener overloaded	Alternating flashes	Alternating flashes	
Mains power interrupted	Rapid flashes		

tip HELPFUL TIP: Refer to Appendix C for Additional LED Indicators



8. Troubleshooting Guide

Symptom	Possible cause	Remedy
The opener does not work from the transmitter	<p>Garage door in poor condition e.g. springs may be broken</p> <p>The opener does not have power</p> <p>The battery in the transmitter is flat</p> <p>The opener has been put into "Vacation Mode"</p> <p>The transmitter button is not programmed to operate the door.</p> <p>Door Code LED is flashing yet the opener is not working.</p>	<p>Check the door's operation (Section 9)</p> <p>Plug a device of similar voltage (e.g. a hairdryer) into the power point and check that it is OK</p> <p>Replace the battery (Section 7.1.2)</p> <p>Turn off "Vacation Mode" (Appendix E, Vacation Mode step E.5)</p> <p>See coding transmitter procedure (Section 6.6)</p> <p>Ensure the correct button on the transmitter is being pressed.</p>
The motor is running but the door remains stationary	The opener is disengaged	Re-engage the opener (Section 5)
The transmitter range varies or is restricted	<p>Variations are normal depending on conditions e.g. temperature or external interference</p> <p>The battery life is exhausted</p> <p>Position of the transmitter in the motor vehicle</p>	<p>See instructions for correct use of transmitter (Section 7.1.1)</p> <p>Refer to battery status (Section 7.1.2)</p> <p>Change the position (Section 7.1)</p>
The door reverses for no apparent reason	<p>This may occur occasionally from environmental conditions such as areas that are windy, dusty or have extreme temperature changes.</p> <p>If Safety Beams are installed they may be partially obstructed.</p>	<p>Put the door into manual (Section 5, take note of the CAUTION) and contact 1300 133 944.</p> <p>Ensure the beam path is not obstructed. If continues, contact your optional extras dealer.</p>
The door opens but will not close	Safety Beam (Optional Accessory) not operating correctly	Contact your optional extras dealer for support.
The Open (Green) LED and Close (Blue) LED are flashing alternatively	Opener is overloaded	Discontinue use and contact 1300 133 944 for support.
The Open (Green) LED continues to flash	Door obstructed when opening	Clear away any obstructions and test door opens correctly. (If door is damaged, contact a door professional).
The Close (Blue) LED continues to flash	<p>Door obstructed when closing</p> <p>Limits may be cleared</p>	<p>Clear away any obstructions and test door closes correctly. (If door is damaged, contact your dealer).</p> <p>Remove all power sources. Wait till all lights are out (10-15 secs), then reconnect power. If Blue LED is flashing, limits are not set. See Section 6 to set LIMITS.</p>



9. After Installation Care

9.1 Service Checklist

Preventative servicing of your garage door and opener, is just as important as servicing your car. Much like the engine of your car, your garage door is made up of numerous moving parts designed to lift and lower your door safely and efficiently.

Ongoing preventative servicing ensures that your door continues to function within factory specifications, greatly reduces the risk of failure and repair bills down the track and ensures you maintain your Warranty.

 **Run the Safety Testing procedures MONTHLY in Section 6.5 to ensure garage door is fit for use.**

 **WARNING! Failure to maintain your your garage door voids the warranty on your garage door opener.**

 **DO NOT DO IT YOURSELF:**
Door adjustments should only be carried out by experienced persons, as this function can be dangerous if not performed under strict safety procedures.

TECHNICIAN CHECKLIST

1. Lubrication of the critical moving parts including chain drive, tracks, wheels or cable drum.
2. Tightening of door mounting points along with door bolts, screws, cables and connectors.
3. Adjustment of spring tension to limit 'spring fatigue'.
4. Adjustment of opener travel limits and force margin to ensure the door opens and closes to specification.
5. Assessment and adjustment of safety components and accessories including safety beams, Auto-Lock and Safe Lock (if installed)
6. Assessment of the door alignment and the diagnosis of irregular operation remedies.
7. Record Cycle count at each service to establish next date of service (as per table)

	SERVICE 1 (12 months after installation or 3,000 cycles)		SERVICE 2 (3 years after installation)		SERVICE 3 (5 years after installation)	
DATE:						
BUSINESS NAME:						
TECHNICIAN NAME:						
PG3 COUNTERS	OPEN	CLOSE	OPEN	CLOSE	OPEN	CLOSE
STALLS						
OBSTRUCTIONS						
SENSOR FAULTS						
OVERLOADS / CUT-OUTS						
WARRANTY CYCLES						
FIRMWARE UPDATE AVAILABLE? IF 'YES' PLEASE UPDATE FIRMWARE	YES	NO	YES	NO	YES	NO
CURRENT FORCE MARGIN						
TECHNICAL SIGNATURE:						

	SERVICE 4 (7 years after installation)		SERVICE 5 (9 years after installation)	
DATE:				
BUSINESS NAME:				
TECHNICIAN NAME:				
PG3 COUNTERS	OPEN	CLOSE	OPEN	CLOSE
STALLS				
OBSTRUCTIONS				
SENSOR FAULTS				
OVERLOADS / CUT-OUTS				
WARRANTY CYCLES				
FIRMWARE UPDATE AVAILABLE? IF 'YES' PLEASE UPDATE FIRMWARE	YES	NO	YES	NO
CURRENT FORCE MARGIN				
TECHNICAL SIGNATURE:				

9.2 Warranty

Warranty conditional on proper servicing as listed in 9.1 Service Checklist. Full details of the warranty are available in your Owners Opener Handbook, from your nearest ATA office or visit the ATA Website ata-aust.com.au.

10. Appendix

A - Adjustment Mode Parameters

Adjustment Mode

Adjustments can be made to functions such as Light times, Auto Close functions etc. The below table shows the parameters that can be altered.

- Press and release the MODE button until the Spanner LED (Adjustment Mode) is highlighted.
- One of the word LED's (LAMP, AUX, etc) will highlight.
- Use the BLUE CLOSE or GREEN OPEN buttons to move to the particular parameter.
- Press RED STOP / SET to enter the adjustment mode.
- The OPEN, STOP and CLOSE LEDs will now flash and indicate the parameters value as shown in table below.
- Use the BLUE CLOSE or GREEN OPEN buttons to adjust the parameter value by one step up or down.
- Press RED STOP / SET to save the new value or MODE to cancel the edit - flashing will stop.
- To enter another parameter repeat from Step a.

LED Indicators	Parameter	OPEN	OPEN & STOP	STOP	CLOSE & STOP	CLOSE	
LAMP LED	Light Time	180s	120s	60s	30s	0s	
AUX LED	Aux Time / Mode	Toggle	60s	30s	1s	Mimic Light	
A/C LED	A/C Function	90s	60s	30s	15s	OFF	
A/C & BEAM LED'S	P.E A/C Function	60s	30s	15s	5s	OFF	
OBST LED	Margin Setting	20 units	15 units	12 units	9 units	7 units	
OPEN / STOP / CLOSE LED'S	PG3 custom setting	When all three lights are illuminated a custom setting is in place. Parameters can be still adjusted to those listed above.					

Auxiliary Output

The auxiliary output can be used to control alarm or another garage door opener. A valid transmission from the pre-coded transmitter will cause the auxiliary output to pulse for approximately 1 (one) second. The maximum DC voltage must not exceed 35 volts DC. Maximum current must not exceed 80 ma.

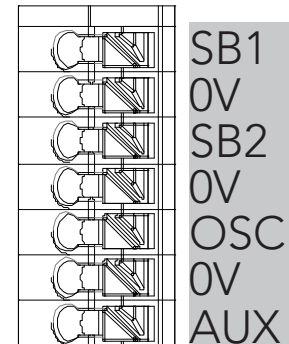

Appendix

B - Setting the PET Mode position

When activated, PET mode drives the door to a preset position from the close position, therefore allowing a pet or parcel to go under the door.

- Drive and stop the door at the desired PET mode open position by pressing the transmitter button coded for Open/Stop/Close operation.
- Press the MODE button twice to highlight the LIMIT LED.
- Press the BLUE CLOSE button to scroll through to highlight the PART LED.
- Press and hold the RED STOP / SET button for 2 seconds and release.

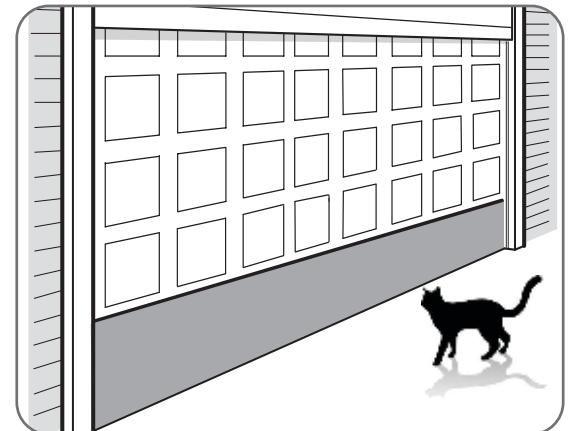

Appendix

C - LED Status

Operation indicators

The below table displays the status of the opener when LEDs are activated.

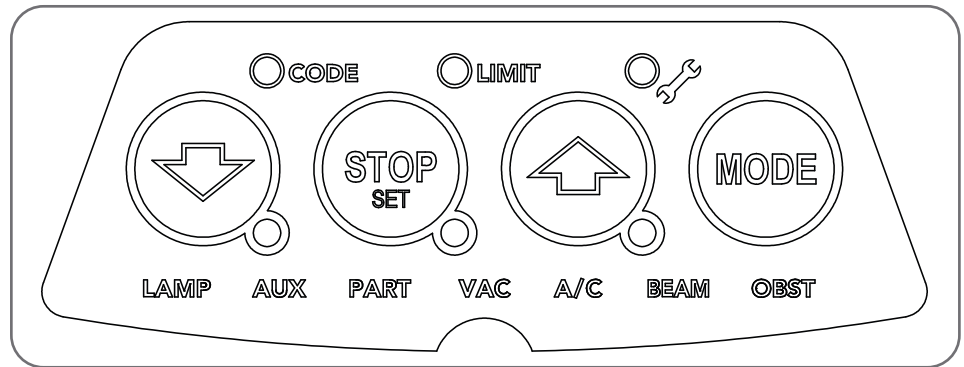

LED Indicators		Status
CODE LED		Flickers with transmitter activity or indicating transmitter may not be coded to the opener.
LIMIT LED		Indicates the opener is in Limit Set Mode
SPANNER LED		Indicates the opener is in Adjustment Mode
CLOSE / STOP / OPEN LED'S		Indicate the door status currently in use (except during power failure, auto-close and part open)
LAMP LED		Only illuminates during the Adjustment Mode to change the light time parameter
AUX LED		Indicates the AUX output is activated, once a transmitter has been coded to the AUX function.
PART LED		Indicates the door is in one of the part open positions.
VAC LED		Indicates the Vacation Mode is active
A/C LED	On STEADY	means the auto-close timer was paused due to the beam being blocked.
	FLASHES	to indicate the auto-close timer is running
BEAM LED	On STEADY	when a beam is blocked.
	FLASHES	when there is a P.E Fault
OBST LED	On STEADY	Obstruction was detected. If door open then obstruction was while closing and vice versa.
	FLASHES	Stall / Overload detected. If door open then stall / overload while closing and vice versa.
SPANNER LED	On STEADY	Indicates the service is due. Beeps three times at start of a drive cycle
	MAIN LIGHT FLASHES	Two flashes indicates that the battery is faulty. Five Flashes indicates that periodic maintenance is due after 3000 drive cycles.
	FLASHES	Indicates a fault. The details is indicated on the other LEDs.
	+ OBST LED + OPEN LED + CLOSE LED + LIMIT LED + CODE LED + OPEN & CLOSE LEDs	Indicates current sensor fault Indicates failed to profile open travel - during limit setting only indicated failed to profile close travel - during limit setting only indicates position wrap fault / position sensor fault indicates memory fault indicates direction fault

Appendix

D - Setting Limits via Transmitter

The GDO-12 HiRo™ has the ability to set travel limits using a transmitter, allowing free movement around the garage to better assess the desired limit positions. In order to use a transmitter, it must first have at least one of its buttons coded to the door controller. The function assigned to the transmitter's buttons is of no concern here as the buttons are temporarily assigned to OPEN, SET, CHANGE DIRECTION and CLOSE (**Fig. D.1**).

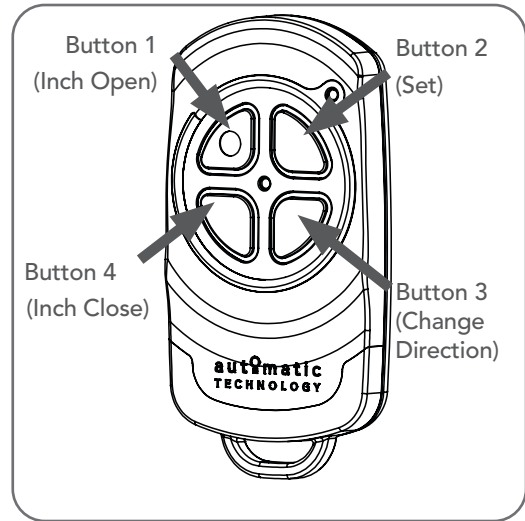

Fig D.1

D.1 Code A Transmitter For Limit Setting

- Switch power on and the BLUE LED on the CLOSE button will start to flash to indicate that the opener is ready to set the Close travel limit
- Press the MODE button to highlight the CODE LED.
- Press and HOLD the RED STOP / SET button to enter the code set procedure.
- Press and hold button 1 on the transmitter for 2 seconds, then release transmitter button.
- Press and hold button 1 on the remote control button again and hold for 2 seconds the release.
- Release the RED STOP / SET button. The transmitter button is now coded, press to test and observe the speed of the door through a full cycle.
- The drive speed is set to the fastest setting by default. This may not be suitable for larger doors:

CLOSE limit:

- Using the programmed transmitter, press and hold the button 4 to close. To inch the door, single presses of the button 4 will move the door to desired limit.
- While inching (to CLOSE) to set the close speed, press and hold button 4 on the remote and by pressing the SET button 2 the opener will cycle through all three speed modes as shown in table.
- Once at the desired speed, release the remote button 4.
- Continue inching the door to the desired position. We recommend the CLOSE limit position being the first point of contact of the rubber strip (at the bottom of the door) with the ground.
- If the door overshoots, press the OPEN button 1 on the remote to move the door in the OPEN direction.
- When the door is at the desired CLOSE position, press the SET button 2, the GREEN LED on the OPEN button will now flash.

OPEN limit:

- Using the programmed transmitter, press and hold the button 1 to open. To inch the door, single presses of the button 1 will move the door to desired limit.
- While inching (to OPEN) to set the open speed, press and hold button 1 on the remote and by pressing the SET button 2 the opener will cycle through all three speed modes as shown in table.
- Once at the desired speed, release the remote button 1.
- Continue inching the door to the desired position. We recommend the OPEN limit position being the height of the garage opening
- If the door overshoots, press the CLOSE button 4 on the remote to move the door in the CLOSE direction.



WARNING! The door will automatically close, open and close again after the next step. Ensure that nothing is in the door's path.

- When the door is at the desired OPEN position, press the SET button 2. The door will now automatically close and open to calculate the safety obstruction settings.



Appendix

E - Additional Transmitter Functions

E.1 Transmitter Button to the Courtesy Light

The transmitter can be programmed to operate the courtesy light on the opener independently of the door moving.

- Press the MODE button to highlight the CODE LED if not already highlighted.
- Use the BLUE CLOSE or GREEN OPEN buttons to scroll through to highlight the LIGHT LED.
- Press and hold the RED STOP/SET button.
- Press one of the four buttons on the transmitter for two (2) seconds, pause for two (2) seconds, then press the same button again for two (2) seconds.
- Release the RED STOP/SET button.
- Press the transmitter button to test.

E.2 Transmitter Button to enable AUX Output

The auxiliary output can be used to control alarm or another garage door opener. This function requires a professional to wire the accessory to the AUX Output before using the below step to code in the transmitter.

- Press the MODE button to highlight the CODE LED if not already highlighted.
- Use the BLUE CLOSE or GREEN OPEN buttons to scroll through to highlight the AUX LED.
- Press and hold the RED STOP/SET button.
- Press one of the four buttons on the transmitter for two (2) seconds, pause for two (2) seconds, then press the same button again for two (2) seconds.
- Release the RED STOP/SET button.
- Press the transmitter button to test.

E.3 Transmitter Button to Operate PART (Partial) Mode

The PART mode position (see 11. Setting Partial Open Position) must set prior to coding a transmitter.

- Press the MODE button to highlight the CODE LED if not already highlighted.
- Use the BLUE CLOSE or GREEN OPEN buttons to scroll through to highlight the PET LED.
- Press and hold the RED STOP/SET button.
- Press one of the four buttons on the transmitter for two (2) seconds, pause for two (2) seconds, then press the same button again for two (2) seconds.
- Release the RED STOP/SET button.
- Press the transmitter button to test.

E.4 Transmitter Button to activate Vacation Mode

The opener can be programmed into a "Vacation Mode" where the opener will not respond to any transmitter except the button of the transmitter that was programmed for vacation mode.

- Press the MODE button to highlight the CODE LED if not already highlighted.
- Use the BLUE CLOSE or GREEN OPEN buttons to scroll through to highlight the VAC LED.
- Press and hold the RED STOP/SET button.
- Press one of the four buttons on the transmitter for two (2) seconds, pause for two (2) seconds, then press the same button again for two (2) seconds.
- Release the RED STOP/SET button.
- Press the transmitter button to test.

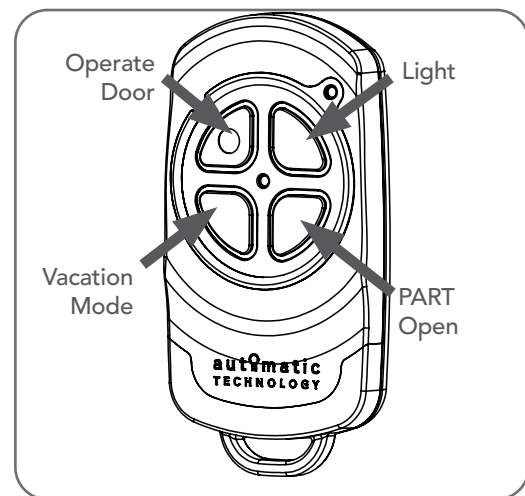

Fig E.1

E.5 Turn Off Vacation Mode

To turn off the Vacation Mode simply press the Vacation mode button and release. Test that Vacation Mode is off by using another transmitter to operate the door.

Automatic Technology office location

Head Office 6-8 Fiveways Blvd, Keysborough 3073 Phone (03) 9791 0200

Prefixed trademarks are the property of Automatic Technology (Australia) Pty Ltd
ABN 11 007 125 368. © 2020 Automatic Technology Australia Pty Ltd.

ata-aust.com.au

SMART
SIMPLE 
SECURE