

EN TRANSLATION OF THE ORIGINAL INSTALLATION AND OPERATING MANUAL

## Garage door operator A 550 L A 800 XL



Dear customer,

Congratulations on your purchase of a product from  
**APERTO Torantriebe GmbH.**

This product has been developed and manufactured under high standards of quality and with reference to ISO 9001. Our passion for the product is just as important to us as the needs and requirements of our customers. We place particular emphasis on the safety and reliability of our products.

Read this installation and operating manual carefully and follow all instructions. This will ensure that you can install and operate the product safely and optimally.

If you have any questions, please contact your specialist retailer, installer or contact.

#### **Information on the operator:**

Serial No.: See the title page of this Installation and Operating Manual (if applicable, warranty sticker).

**Year of manufacture: from 10.2016**

#### **Information on the Installation and Operating Manual**

Version of the installation and operating manual:

A-550L-800XL\_S10608-00001\_482017\_0-DRE\_Rev-B\_EN

#### **Warranty**

The warranty complies with statutory requirements. The contact person for warranties is the qualified dealer. The warranty is only valid in the country in which the operator was purchased. There is no warranty for consumables such as batteries, accumulators and safety products or light bulbs. This also applies for wear parts. The operator is only designed for a limited frequency of use. More frequent use leads to increased wear.

#### **Contact data**

If you require after-sales service, spare parts or accessories, please contact your specialist retailer, your installer or contact:

#### **APERTO Torantriebe GmbH**

Hans-Böckler-Str. 29

D-73230 Kirchheim/Teck

Germany

[www.aperto-torantriebe.de](http://www.aperto-torantriebe.de)

#### **Feedback on this Installation and Operating Manual**

We have tried to make the Installation and Operating Manual as easy as possible to follow. If you have any suggestions as to how we could improve it or if you think more information is needed, please send your suggestions to us:



**+49 (0) 7021 9447-25**



**[info@aperto-torantriebe.de](mailto:info@aperto-torantriebe.de)**

#### **Service**

If you require service, please contact us on our service hotline (fee required) or see our web site:



**+49 (0) 7021 8001-552**

(0.14 euros/minute from land line telephones in Germany, mobile prices may vary)

**[info@aperto-torantriebe.de](mailto:info@aperto-torantriebe.de)**

#### **Copyright and proprietary rights**

The manufacturer retains the copyright for this Installation and Operating Manual. No part of this Installation and Operating Manual may be reproduced in any form without the written permission of **APERTO Torantriebe GmbH** or processed, copied, or distributed using electronic systems. Violations of the specifications above will lead to claims for damages. All brands mentioned in this Installation and Operating Manual are the property of their respective manufacturer and hereby recognised as such.

# Table of contents

<b>1. About this Installation and Operating Manual</b>	<b>5</b>	9.4 Mechanical adjustment of the end positions	37
1.1 Storage and circulation of the Installation and Operating Manual	5	9.5 Attaching information sign and warning signs	38
1.2 Important for translations	5	<b>10. Connections and special functions of the motor carriage</b>	<b>39</b>
1.3 Description of the product type	5	10.1 Motor carriage circuit board	39
1.4 Target groups of the Installation and Operating Manual	5	10.2 Connection options on the motor carriage	40
1.5 Explanation of warning symbols and notes	5	10.3 Reducing the illumination power of LEDs	40
1.6 Special warnings, hazard symbols and mandatory signs	6	10.4 Explanation of the radio channels	40
1.7 Information regarding the depiction of text	8	10.5 Programming the transmitter	41
1.8 Intended use of the operator	8	10.6 Cancelling programming mode	41
1.9 Improper use of the operator	9	10.7 Deleting a transmitter button from the radio channel	41
1.10 Qualifications of personnel	9	10.8 Deleting transmitter completely from the receiver	41
1.11 For the user	10	10.9 Deleting radio channel in the receiver	42
<b>2. General safety instructions</b>	<b>11</b>	10.10 Deleting all radio channels in the receiver	42
2.1 Basic safety instructions for operation	11	10.11 Resetting the control unit	42
2.2 Additional safety information for the radio remotecontrol	13	10.12 Setting the DIP switches on the motor carriage	43
<b>3. Description of function and product</b>	<b>14</b>	10.13 Setting automatic closing function - defining basic values	43
3.1 The operator and its mode of operation	14	10.14 Setting the lighting function	44
3.2 Safety equipment	14	10.15 Setting partial opening	44
3.3 Product designation	15	10.16 Deleting partial opening	45
3.4 Explanation of tool symbols	15	10.17 Wicket door safety device	45
3.5 Scope of delivery	16	10.18 SOMlink	45
3.6 Dimensions	17	<b>11. Connections and special functions of the ceiling control unit</b>	<b>46</b>
3.7 Technical data	17	11.1 Ceiling control unit circuit board	46
3.8 Door types and accessories	18	11.2 Connection options to the ceiling control unit	47
<b>4. Tools and protective equipment</b>	<b>19</b>	11.3 Setting the DIP switches on the ceiling controlunit	49
4.1 Required tools and personal protective equipment	19	11.4 Button 2 for partial opening	49
<b>5. Declaration of Installation</b>	<b>20</b>	11.5 Deleting partial opening	50
<b>6. Installation</b>	<b>21</b>	11.6 Photocell and frame photocell	50
6.1 Important information on installation	21	11.7 Wallstation	51
6.2 Preparation for installation	23	11.8 Conex	52
6.3 Installation of the operator system	24	11.9 Output OC	52
6.4 Installation on the door	26	11.10 Relay	52
<b>7. Removing and fastening covers</b>	<b>31</b>	11.11 Installing and removing the accumulator	53
7.1 Cover of the motor carriage	31	<b>12. twin operation</b>	<b>55</b>
7.2 Cover of the ceiling control unit	32	12.1 twin operation	55
<b>8. Electrical connection</b>	<b>33</b>	12.2 Installing the operators	55
8.1 Connection to a power outlet	33	12.3 Selecting and configuring master and slave	55
<b>9. Initial operation</b>	<b>34</b>	12.4 Partial opening	56
9.1 Safety information for initial operation	34	12.5 Defined opening and closing	56
9.2 Initial operation	35	12.6 Door status display	56
9.3 Detecting obstacles during the force programming run	37	12.7 Lighting for twin operation	56
		12.8 Photocell	56
		12.9 External button	56
		12.10 Reset	56

---

<b>13. Function test and final test</b>	<b>57</b>
13.1 Testing obstacle detection	57
13.2 Handover of door system	58
<b>14. Operation</b>	<b>60</b>
14.1 Safety information on operation	60
14.2 Handover to the user	61
14.3 Operating modes of door movement	62
14.4 Obstacle detection	63
14.5 Power-saving mode	63
14.6 Operation during power failure	63
14.7 Function of the emergency release	63
<b>15. Maintenance and care</b>	<b>65</b>
15.1 Safety instructions for maintenance and care	65
15.2 Maintenance schedule	66
15.3 Care	67
<b>16. Troubleshooting</b>	<b>68</b>
16.1 Safety instructions for troubleshooting	68
16.2 Troubleshooting	69
16.3 Time sequences of operator lighting in normal mode and in case of faults	70
16.4 Troubleshooting table	71
16.5 Replacing the motor carriage	72
<b>17. Taking out of operation, storage and disposal</b>	<b>73</b>
17.1 Taking the operator out of operation and disassembly	73
17.2 Storage	74
17.3 Disposal of waste	74
<b>18. Short instructions for installation</b>	<b>76</b>
<b>19. Connection diagrams and functions of theDIP switches for A 550 L and A 800 XL</b>	<b>79</b>

# 1. About this Installation and Operating Manual

## 1.1 Storage and circulation of the Installation and Operating Manual

Read this Installation and Operating Manual carefully and completely before installation, commissioning and operation and also before removal. Follow all warnings and safety instructions.

Keep this Installation and Operating Manual accessible to all users at all times at the place of use.

A replacement installation and operating manual can be downloaded from **APERTO Torantriebe GmbH** at: [www.aperto-torantriebe.de](http://www.aperto-torantriebe.de)

During the transfer or resale of the operator to third parties, the following documents must be passed on to the new owner:

- EC Declaration of Conformity
- handover protocol and inspection book
- this Installation and Operating Manual
- proof of regular care, maintenance and testing
- documents recording retrofitting and repairs

## 1.2 Important for translations

This original Installation and Operating Manual was written in German. The other available languages are translations of the German version. You can get the original Installation and Operating Manual by scanning the QR code:



<http://som4.me/aperto-orig-A550-Rev-B>

For other language versions, see: [www.aperto-torantriebe.de](http://www.aperto-torantriebe.de)

## 1.3 Description of the product type

The operator has been constructed according to state-of-the-art technology and recognised technical regulations and is subject to the EC Machinery Directive (2006/42/EC). The operator is fitted with a radio receiver. Optionally available accessories are also described. The version can vary depending on the type. This means the use of accessories can vary.

## 1.4 Target groups of the Installation and Operating Manual

The Installation and Operating Manual must be read and observed by everyone assigned with one of the following tasks:

- Unloading and in-house transport
- Unpacking and installation
- Initial operation
- Setting
- Usage
- Maintenance, testing and care
- Troubleshooting
- Disassembly and disposal

## 1.5 Explanation of warning symbols and notes

The warnings in this Installation and Operating Manual are structured as follows.



Hazard symbol



**Signal word**

Type and source of hazard  
Consequences of the hazard

► Preventing/avoiding the hazard

The hazard symbol indicates the hazard. The signal word is linked to a hazard symbol. The hazard is classified into three classes depending on its danger level:

**DANGER**

**WARNING**

**CAUTION**

# 1. About this Installation and Operating Manual

There are three different classifications of hazards.

 **DANGER**  
Describes an immediate danger that leads to serious injury or death  
Describes the consequences of the danger to you or other persons.  
▶ Follow the instructions for avoiding or preventing the danger.



 **WARNING**  
Describes a potential danger of serious injury or death  
Describes the potential consequences of the danger to you or other persons.  
▶ Follow the instructions for avoiding or preventing the danger.



 **CAUTION**  
Describes a potential danger of a hazardous situation  
Describes the potential consequences of the danger to you or other persons.  
▶ Follow the instructions for avoiding or preventing the danger.

The following symbols are used for notes and information:

 **NOTE**  
Describes additional information and useful notes for correct use of the operator without endangering persons. If it is not observed, property damage or faults in the operator or door may occur.

 **INFORMATION**  
Describes additional information and useful tips.  
Functions for optimum usage of the operator are described.

 **INFORMATION**  
 This symbol indicates that all operator components that have been taken out of service must not be disposed of with household waste, as they contain hazardous substances. The components must be disposed of correctly at an authorised recycling centre. The local and national regulations must be observed.

 **INFORMATION**  
 This symbol indicates that all old accumulators and batteries must not be disposed of with household waste. Old accumulators and batteries contain hazardous substances. These must be disposed of properly at municipal collection points or in the containers provided by dealers. The local and national regulations must be observed.

The following symbols are used in the figures and text.

 Continue reading the Installation and Operating Manual for more information.

 Disconnect the operator from the mains voltage

 Connect the operator to the mains voltage

 Symbol refers to factory settings

 Symbol refers to a WiFi-enabled device, such as a smartphone

## 1.6 Special warnings, hazard symbols and mandatory signs

To specify the source of danger more precisely, the following symbols are used together with the above-mentioned hazard symbols and signal words. Follow the instructions to prevent a potential hazard.

 **DANGER**  
**Danger due to electric current!**  
Contact with live parts may result in electric current flowing through the body. Electric shock, burns or death will result.  
▶ Installation, testing and replacement of electrical components may only be carried out by a **trained electrician**.

# 1. About this Installation and Operating Manual



## **WARNING**

**Danger of falling!**  
Unsafe or defective ladders may tip and cause serious or fatal accidents.

- ▶ Use only a non-slip, stable ladder.



## **WARNING**

**Danger for trapped persons!**  
Persons may be trapped inside the garage. If trapped persons cannot free themselves, severe injury or death may result.

- ▶ If there is no second entrance to the garage, you must have a release lock or a Bowden wire for unlocking from the outside installed. This can be used to free persons who cannot free themselves.



## **WARNING**

**Danger due to projecting parts!**  
Parts must not project into public roads or footpaths. This also applies while the door is moving. Persons and animals may be seriously injured.

- ▶ Keep public roads and footpaths clear of projecting parts.



## **WARNING**

**Danger due to falling parts!**  
Parts of the door may become detached and fall. If persons or animals are hit, this may cause serious injury or death.

- ▶ The door must not bend, rotate or twist when you open or close it.



## **WARNING**

**Danger of entrapment!**  
Persons or animals in the movement area of the door may be trapped and pulled along with the door. Severe injuries or death may result.

- ▶ Keep clear of the moving door.



## **WARNING**

**Danger of crushing and shearing!**  
If the door moves and there are persons or animals in the movement area, crushing and shearing injuries may be caused by the mechanism and safety edges of the door.

- ▶ Never put your hand near the door or near moving parts when the door is moving.



## **WARNING**

**Danger of tripping and falling!**  
Unsafely positioned parts such as packaging, operator parts or tools may cause trips or falls.

- ▶ Keep the installation area free of unnecessary items.



## **WARNING**

**Danger due to optical radiation!**  
Looking into an LED at short range for an extended period may cause optical glare. This will temporarily reduce vision. This may cause serious or fatal injury.

- ▶ Never look directly into an LED.



## **WARNING**

**Danger due to hot parts!**  
After frequent operation, parts of the motor carriage or the control unit may become hot. If the cover is removed and hot parts are touched, they may cause burns.

- ▶ Allow the operator to cool down before removing the cover.

# 1. About this Installation and Operating Manual

The following mandatory signs inform the user that actions are required. The requirements described must be complied with.

 	<b>WARNING</b> <b>Risk of eye injury!</b> Chips flying when drilling may cause serious injuries to eyes and hands. ▶ Wear safety glasses.
 	<b>WARNING</b> <b>Risk of injury in the head region!</b> Impact with suspended objects may cause serious abrasions and cuts. ▶ Wear a safety helmet.
 	<b>CAUTION</b> <b>Risk of injury to hands!</b> Rough metal parts may cause abrasions and cuts when picked up or touched. ▶ Wear safety gloves.

## 1.7 Information regarding the depiction of text

- Stands for directions for an action  
⇒ Stands for the results of the action
- Lists are shown as a list of actions:

- List 1
- List 2

1, A **1** A Item number in the figure refers to a number in the text.

Important text items, for example in directions for actions, are emphasised in **bold**.

References to other chapters or sections are in **bold** type and set in "quotation marks."

## 1.8 Intended use of the operator

The operator is intended exclusively to open and close doors. Any other use does not constitute intended use. The manufacturer accepts no liability for damage resulting from use other than intended use. The user bears the sole responsibility for any risk involved. It also voids the warranty.

Any changes to the operator must be made with original **SOMMER** accessories only and only to the extent described.

Doors automated with this operator must comply with all valid international and domestic standards, directives and regulations. These include EN 12604, EN 12605 and EN 13241-1.

The operator may only be used:

- in combination with door types in the reference list which can be found at:



<http://som4.me/cgdo>

- if the EC Declaration of Conformity has been issued for the door system
- if the CE mark and the type plate for the door system have been attached to the door
- if the handover protocol and the inspection book have been completed and are available
- if the installation and operating manuals for the operator and the door are present
- as specified in this Installation and Operating Manual
- in good technical condition
- with attention to safety and hazards by trained users.



# 1. About this Installation and Operating Manual

## 1.9 Improper use of the operator

Any other use or additional use that has not been described in Chapter "1.8 Intended use of the operator" constitutes improper use. The user bears the sole responsibility for any risk involved.

The manufacturer's warranty will be voided by:

- damage caused by other use and improper use
- use with defective parts
- unauthorised modifications to the operator
- modifications and non-approved programming of the operator and its components

The door must not be part of a fire protection system, an escape route or an emergency exit that automatically closes the door in the event of fire. Installation of the operator will prevent automatic closing. Observe the local building regulations.

The operator may not be used in:

- areas with explosion hazard
- very salty air
- aggressive atmosphere, including chlorine

## 1.10 Qualifications of personnel

People under the influence of drugs, alcohol, or medications that can influence their ability to react may **not** work on the operator.

After installation of the operator, the person responsible for the installation of the operator must complete an EC Declaration of Conformity for the door system in accordance with Machinery Directive 2006/42/EC.

The CE mark and the type plate must be attached to the door system. This also applies if the operator is retrofitted to a manually operated door. This documentation must be included with the Installation and Operating Manual.

All documents and the handover protocol must be handed over to the user.

The following is available for this purpose:

- handover protocol for the operator
- Declaration of Conformity



<http://som4.me/konform>

## Qualified specialist for installation, commissioning and disassembly

This Installation and Operating Manual must be read, understood and complied with by a qualified specialist who installs or performs maintenance on the operator. Work on the electrical system and live parts must be performed by a **trained electrician** in accordance with EN 50110-1.

Installation, initial operation and disassembly of the operator may only be performed by a **qualified specialist**.

The qualified specialist must be familiar with the following standards:

- EN 13241-1 Doors and gates - Product standard
- EN 12604 Doors and gates - Mechanical aspects - Requirements
- EN 12605 Doors and gates - Mechanical aspects - Test methods
- EN 12445, EN 12453 Safety in use of power-operated doors

A qualified specialist is a person commissioned by the installer.

The qualified specialist must instruct the user:

- on the operation of the operator and its dangers
- on the handling of the manual emergency release
- on regular maintenance which the user can carry out

The user must be informed that other users must be instructed on the operation of the operator, its dangers as well as the emergency release.

The user must be informed about which work may only be performed by a qualified specialist:

- installation of accessories
- settings
- regular maintenance, testing and care
- troubleshooting and repairs

The following documents for the door system must be handed over to the user:

- EC Declaration of Conformity
- handover protocol and inspection book
- the Installation and Operating Manuals for the operator and the door

# 1. About this Installation and Operating Manual

---

## 1.11 For the user

The user must ensure that the CE mark and the type plate have been attached to the door system.

The following documents for the door system must be handed over to the user:

- the Installation and Operating Manuals for the operator and the door
- inspection book
- EC Declaration of Conformity
- handover protocol

The user must always keep this Installation and Operating Manual at the place of use, ready for consultation and accessible to all users.

The user is responsible for:

- the intended use of the operator
- its good condition
- instructing all users how to use the door system and in the associated hazards
- operation
- maintenance, inspection and care by a qualified specialist
- troubleshooting and repair by a qualified specialist

The operator must not be used by persons with restricted physical, sensory or mental capacity or who lack experience and knowledge. All users must be specially instructed and have read and understood the Installation and Operating Manual.

Children must never play with or use the operator, even under supervision. Children must be kept clear of the operator. Handheld transmitters or other command devices must never be given to children. Handheld transmitters must be safely stored and protected against unintended and unauthorised use.

The user must observe the accident prevention regulations and the applicable standards in Germany. In other countries, the user must comply with the applicable national regulations. The guideline "Technical regulations for workplaces ASR A1.7" of the German committee for workplaces (ASTA) is applicable for commercial use. The guidelines described must be observed and complied with. This applies for use in Germany. In other countries, the user must comply with the applicable national regulations.

## 2. General safety instructions

### 2.1 Basic safety instructions for operation

Follow the basic safety instructions listed below.

The operator must not be used by persons with restricted physical, sensory or mental capacity or who lack experience and knowledge. All users must be specially instructed and have read and understood the installation and operating instructions.

Children must never play with or use the operator, even under supervision. Children must be kept clear of the operator. Handheld transmitters or other command devices must never be given to children. Handheld transmitters must be safely stored and protected against unintended and unauthorised use.



#### **DANGER**

**Danger if not observed!**  
If safety instructions are not observed, serious injury or death may result.

- ▶ All safety instructions must be complied with.



#### **DANGER**

**Danger due to electric current!**  
Contact with live parts may result in electric current flowing through the body. Electric shock, burns or death will result.

- ▶ Installation, testing and replacement of electrical components must be carried out by a **trained electrician**.
- ▶ Disconnect the mains plug before working on the operator.
- ▶ If an accumulator is connected, disconnect it from the control unit.
- ▶ Check that the operator is not live.
- ▶ Secure the operator against being switched back on.



#### **DANGER**

**Danger due to use of the operator with incorrect settings or when it is in need of repair!**

**If the operator is used despite incorrect settings or if it is in need of repair, severe injury or death may result.**

- ▶ The operator may only be used with the required settings and in the proper condition.
- ▶ You must have faults repaired professionally without delay.



#### **DANGER**

**Danger of hazardous substances!**  
Improper storage, use or disposal of accumulators, batteries and operator components are dangerous for the health of humans and animals. Serious injury or death may result.

- ▶ Accumulators and batteries must be stored out of the reach of children and animals.
- ▶ Keep accumulators and batteries away from chemical, mechanical and thermal influences.
- ▶ Do not recharge old accumulators and batteries.
- ▶ Components of the operator as well as old accumulators and batteries must not be disposed of with household waste. They must be disposed of properly.



#### **WARNING**

**Danger for trapped persons!**  
Persons may be trapped inside the garage. If trapped persons cannot free themselves, severe injury or death may result.

- ▶ Test the operation of the emergency release regularly from inside and if necessary, also from outside.
- ▶ You must have faults repaired professionally without delay.

## 2. General safety instructions



### **WARNING**

**Danger due to projecting parts!**  
Parts must not project into public roads or footpaths. This also applies while the door is moving. Persons and animals may be seriously injured.

- ▶ Keep public roads and footpaths clear of projecting parts.



### **WARNING**

**Danger due to falling parts of doors!**  
Actuating the emergency release can lead to uncontrolled door movement if

- springs are weakened or broken.
- the door has not been optimally weight-balanced.

**Falling parts may cause a hazard. Severe injuries or death may result.**

- ▶ Check the weight balance of the door at regular intervals.
- ▶ Pay attention to the movement of the door when the emergency release is actuated.
- ▶ Keep clear of the movement area of the door.



### **WARNING**

**Danger of entrapment!**  
Persons or animals in the movement area of the door may be trapped and pulled along with the door. Severe injuries or death may result.

- ▶ Keep clear of the movement area of the door.



### **WARNING**

**Danger of crushing and shearing!**  
If the door moves and there are persons or animals in the movement area, crushing and shearing injuries may be caused by the mechanism and safety edges of the door.

- ▶ Only use the operator when you have a direct view of the door.
- ▶ All danger zones must be visible during the entire door operation.
- ▶ Always keep the moving door in sight.
- ▶ Keep persons and animals clear of the range of movement of the door.
- ▶ Never put your hand near the door when it is moving or near moving parts. In particular, do not reach into the moving push arm.
- ▶ Do not reach into the ceiling suspension unit when the motor carriage is running along the track.
- ▶ Do not drive through the door until it has opened completely.
- ▶ Store the handheld transmitter so that unauthorised or accidental operation, e.g., by children or animals, is impossible.
- ▶ Never stand under the opened door.



### **WARNING**

**Danger due to optical radiation!**  
Looking into an LED at short range for an extended period may cause optical glare. This may temporarily reduce vision. This may cause serious or fatal accidents.

- ▶ Never look directly into an LED.



### **NOTE**

Dispose of all components in accordance with local or national regulations to avoid environmental damage.

## 2. General safety instructions



### NOTE

The motor carriage is supplied with safety low voltage via the chain and the track. The use of oil or grease will greatly reduce the conductivity of the chain, track and motor carriage. This may result in faults due to inadequate electrical contact. The chain and track are maintenance-free and must not be oiled or greased.



### NOTE

Objects in the movement area of the door may be jammed and damaged. Objects must not be in the range of movement of the door.

### 2.2 Additional safety information for the radio remote control

Follow the basic safety instructions listed below.



### WARNING

**Danger of crushing and shearing!**  
If the door is not visible and the radio control is operated, crushing and shearing injuries to persons or animals may be caused by the mechanism and safety edges of the door.

- ▶ In particular when operating control elements such as the radio control, all danger zones must be visible during the entire door operation.
- ▶ Always keep the moving door in sight.
- ▶ Keep persons and animals clear of the range of movement of the door.
- ▶ Never put your hand near the door when it is moving or near moving parts.
- ▶ Do not drive through the door until it has opened completely.
- ▶ Store the handheld transmitter so that unauthorised or accidental operation, e.g., by children or animals, is impossible.
- ▶ Never stand under the opened door.



### NOTE

If the door is not in view and the radio remote control is actuated, objects in the movement area of the door may be jammed and damaged. Objects must not be in the range of movement of the door.

The user of the radio system is not protected against interference due to other telecommunications equipment or devices. This includes radio-controlled systems that are licensed to operate in the same frequency range. If significant interference occurs, please contact your appropriate telecommunications office which has radio interference measuring equipment or radio location equipment.

You can find the Declaration of Conformity for the radio here:

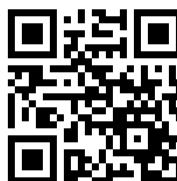

<http://som4.me/konform-funk>

## 3. Description of function and product

### 3.1 The operator and its mode of operation

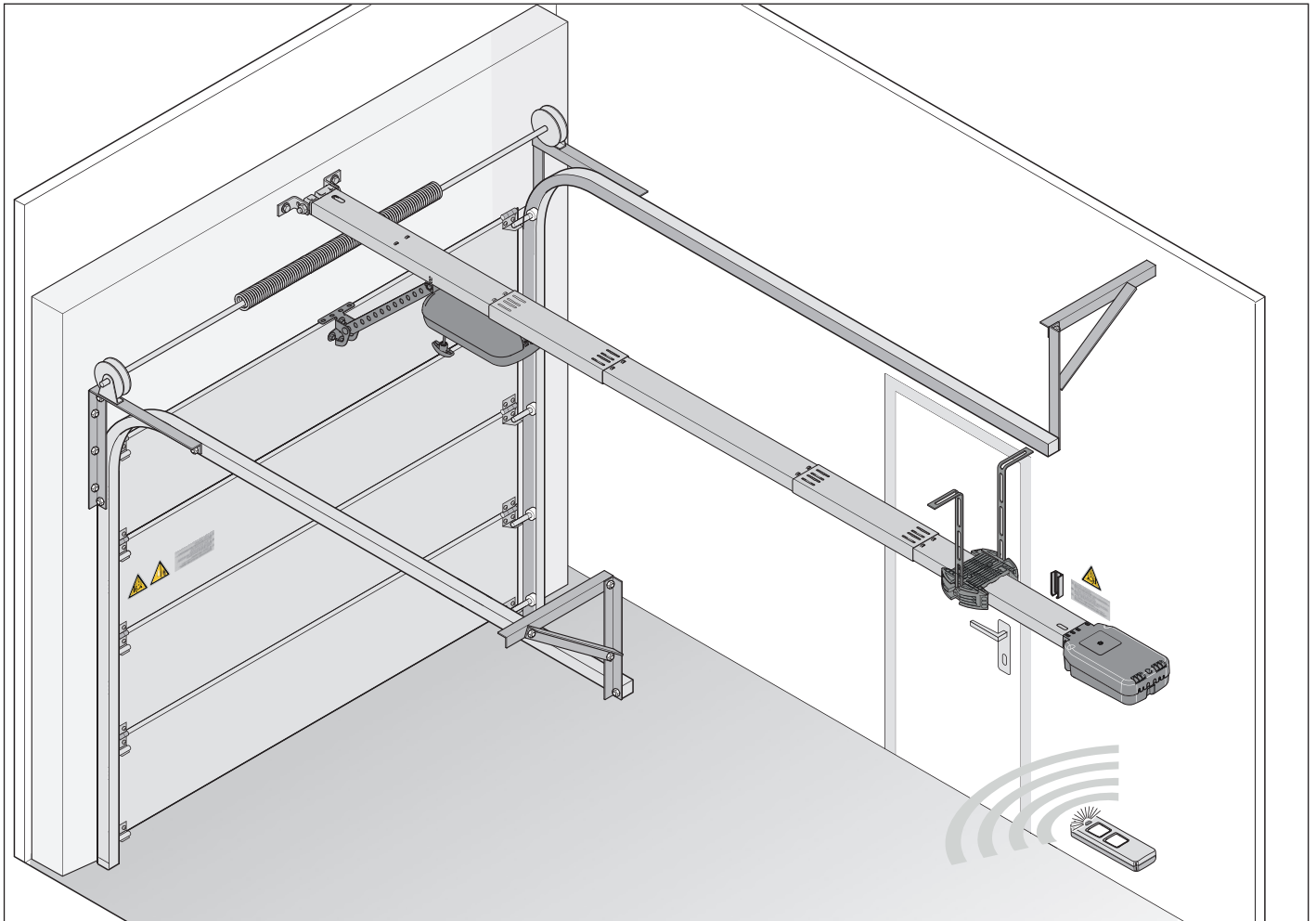

Fig. Door structure with operator

Sectional doors and other door types can be opened and closed with the electrically powered operator and its available accessories. The operator can be controlled with a handheld transmitter.

The track is mounted on the ceiling and the lintel above the garage door. The motor carriage is attached to the door by a push arm. The motor carriage moves along the track on a spring-mounted chain and opens or closes the door.

The handheld transmitter can be stored in a holder in the garage or in the vehicle.

A plug-in light for the ceiling control unit is available as an accessory. It is automatically activated during operation. The use of accessories can vary depending on the type. For more information on using the operator with different door types or accessories, contact your specialist dealer.

### 3.2 Safety equipment

The operator stops and reverses slightly if it encounters an obstacle. This prevents injury and damage to property. The door will be partially or completely opened, depending on the setting.

In the event of a power failure, the door can be opened from the inside via an emergency release handle or from the outside with a Bowden wire or emergency release lock. For more information, contact your specialist dealer.

# 3. Description of function and product

## 3.3 Product designation

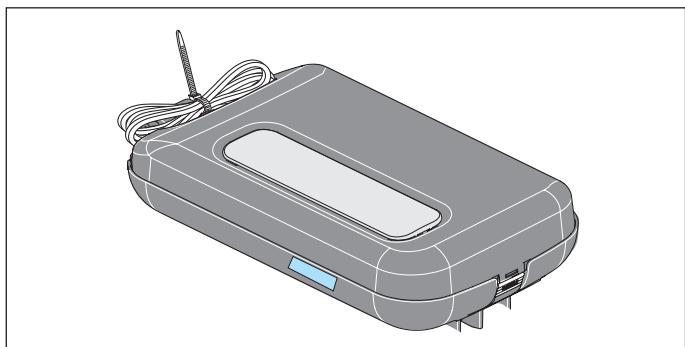

Fig. Motor carriage with type plate and device specifications

The type plate includes:

- type designation
- item number
- date of manufacture with month and year
- serial number

In case of questions or service, please supply the type designation, the date of manufacture and the serial number.

## 3.4 Explanation of tool symbols

### Tool symbols

These symbols refer to the use of tools required for installation.



Phillips screwdriver



Metal drill 5 mm



Masonry drill 10 mm



Fork wrench 10/13/17 mm



Ratchet wrench 10/13/17 mm

### Other symbols



Drilling depth



Audible engaging or clicking noise

# 3. Description of function and product

## 3.5 Scope of delivery

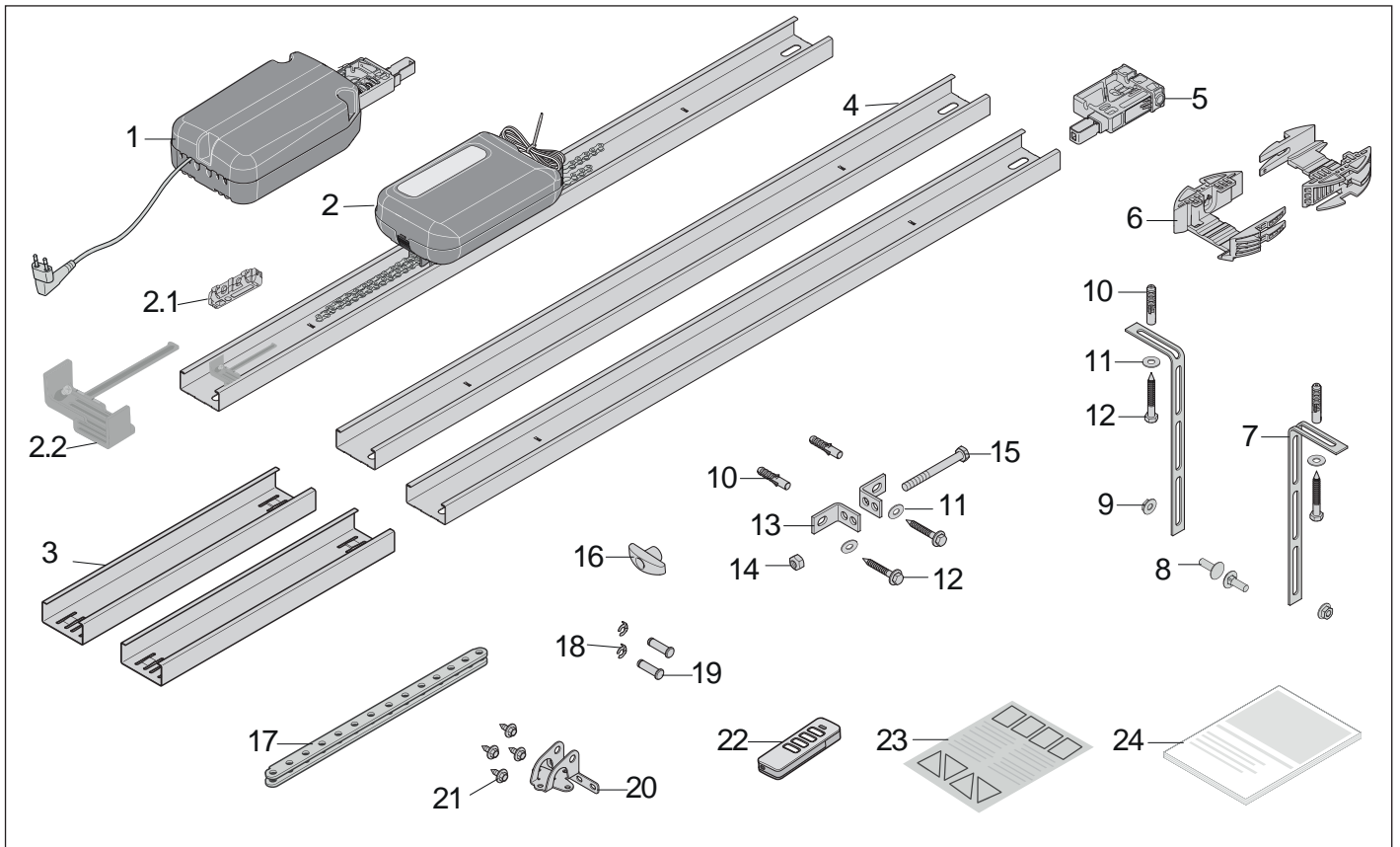

Fig. Scope of delivery

- 1) Ceiling control unit
- 2) Track, pre-assembled with **1 x limit stop**, chain and motor carriage
- 2.1) Isolator, **included with the track**
- 2.2) Limit stop, **pre-assembled on the track**
- 3) Connecting sleeves, 2 x
- 4) Track, 2 x
- 5) Plug-in unit, pre-assembled
- 6) Ceiling holder, 2-part
- 7) Perforated strip, angled, 2 x
- 8) Screw M8 x 20 mm, 2 x
- 9) Hexagonal nut self-locking M8, 2 x
- 10) S10 wall plugs, 4 x
- 11) Washer, 4 x
- 12) Screw 8 x 60 mm, 4 x
- 13) Lintel bracket, 2 x
- 14) Hexagonal nut, self-locking M10
- 15) Hexagonal head screw M10 x 100 mm
- 16) Emergency release handle
- 17) Push arm, straight
- 18) Safety bolt 10 mm, 2 x
- 19) Bolt 10 x 34.5 mm, 2 x
- 20) Door bracket
- 21) Combination self-tapping screw, 4 x
- 22) Handheld transmitter, **preprogrammed**, channel 1 pulse sequence, **with CR 2032, 3 V lithium battery**
- 23) Information sticker for garage interior
- 24) Installation and Operating Manual

When unpacking, make sure that all items are included in the packages. If anything is missing, contact your specialist dealer. The actual scope of delivery may vary depending on the type or customer specifications.



### 3. Description of function and product

#### 3.6 Dimensions

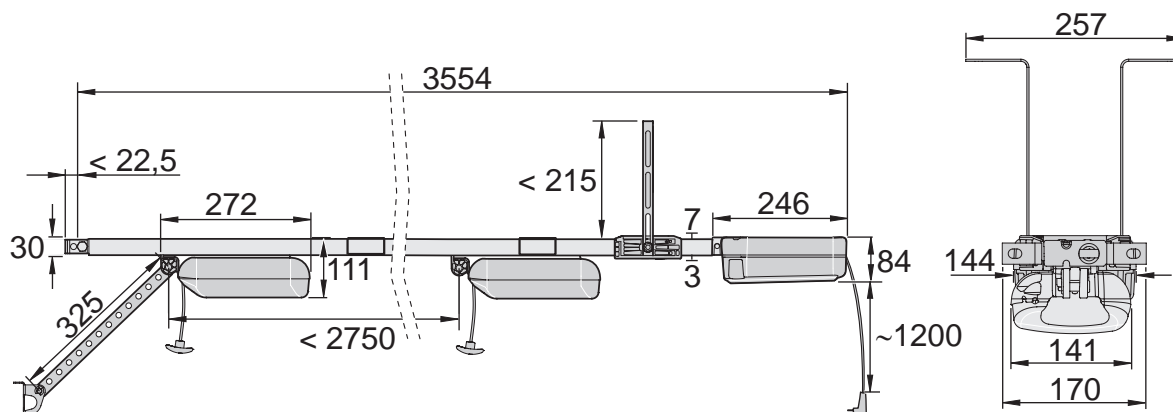

Fig. Dimensions (all dimensions are in mm)

#### 3.7 Technical data

	A 550 L	A 800 XL	
Rated voltage	220 V - 240 V AC		
Rated frequency	50/60Hz		
Memory positions in radio receiver	20		
Duty cycle	S3 = 40%		
Operating temperature	-25 °C to +65 °C		
Emission value according to operating environment	< 59 dBA – operator only		
IP protection class	IP21		
IP-code	II		
Travel length max.	2750 mm		
Travel length including extension max.	4,900 mm (2x 1,096 mm)	6,000 mm (3x 1,096 mm)	
Speed*	200 mm/s	180 mm/s	
Max. pull and pushing force	550 N	800 N	
Rated pull force	180 N	240 N	
Rated power consumption**	95 W	130 W	
Rated current consumption**	0.5 A	0.7 A	
Power consumption in power-saving mode	< 3 W	< 1W	
Door weight max.*	approx. 100 kg	approx. 140 kg	
Max. door width / door height***	Sectional doors	3,500 mm/ 2,500 mm	6,000 mm/ 2,500 mm
	One piece doors	3,500 mm / 2,750 mm	6,000 mm / 2,750 mm
	Up-and-over doors	3,500 mm / 2,050 mm	6,000 mm / 2,050 mm
	Side-opening sectional doors/ Side-opening doors	2,500 mm (4,500 mm)/ 2,300 mm	2,500 mm (5,750 mm)/ 2,800 mm
Max. recommended no. of spaces	30	50	



\* Depending on door and the operating conditions

\*\* Values apply without lighting

\*\*\* Reference value, depending on the door construction

# 3. Description of function and product

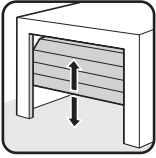
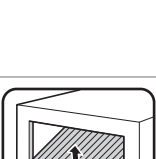
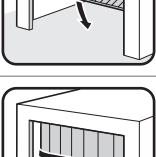
## 3.8 Door types and accessories

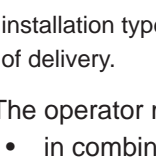
Door type	Accessories
	No accessories required
	Sectional door fitting with curved push arm*
	Sectional door fitting without curved push arm**
	No accessories required
	Curved arm*
	Side-opening sectional door fitting**

\* Accessories not included in the scope of delivery

\*\* The standard fitting can also be used depending on the installation type. Custom fittings are not included in the scope of delivery.

The operator may only be used:

- in combination with door types in the reference list which can be found at:



<http://som4.me/cgdo>

A number of accessories are available for the operator. Here are a few examples:

Accessories	Function
Buzzer	Pluggable acoustic signal generator Option of alarm tone when a break-in attempt occurs or a warning tone in the case of a wicket door contact, for example
Lumi base+	Supplemental lighting Provides more light in the garage
Relay	Additional functions External lighting (garage lighting or outside lighting) or door status display is enabled
Accu	Accumulator Operator is supplied with power during a power failure

For more information on accessories such as track extensions, additional locking mechanisms, custom fittings or different transmitters, contact your specialist dealer or see:

[www.sommer.eu](http://www.sommer.eu)

## 4. Tools and protective equipment

### 4.1 Required tools and personal protective equipment

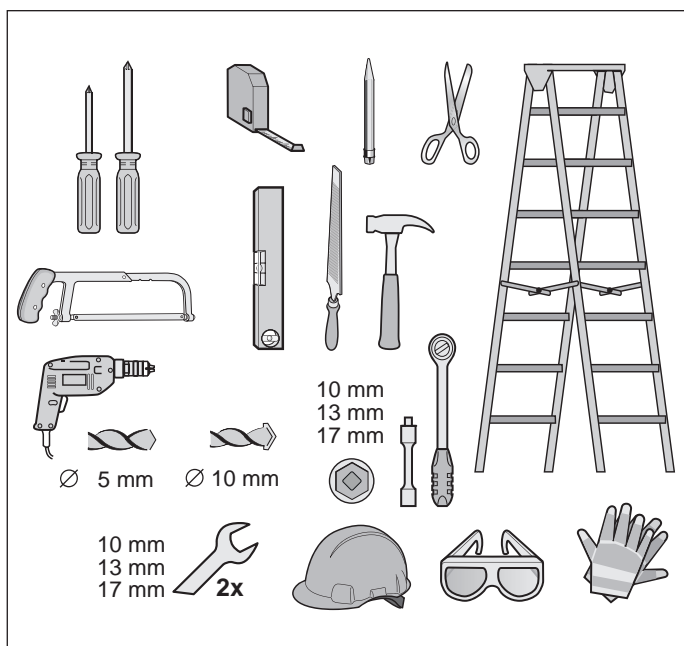

Fig. Recommended tools and personal protective equipment for installation

You will require the tools shown above to assemble and install the operator. Lay out the required tools beforehand to ensure fast and safe installation.



#### CAUTION

**Risk of injury to hands!**  
Rough metal parts may cause abrasions and cuts when picked up or touched.



► Wear safety gloves when deburring or performing similar work.

Wear your personal protective equipment. This includes safety glasses, safety gloves and a safety helmet.



#### WARNING

**Risk of eye injury!**  
Chips flying when drilling may cause serious injuries to eyes and hands.

► Wear safety glasses when drilling.



#### WARNING

**Risk of injury in the head region!**  
Impact with suspended objects may cause serious abrasions and cuts.

► You must wear a safety helmet when installing suspended parts.



# 5. Declaration of Installation

## Declaration of installation

for the installation of an incomplete machine  
in accordance with the Machinery Directive 2006/42/EC, Annex II, Section 1 B

**SOMMER Antriebs- und Funktechnik GmbH**  
Hans-Böckler-Straße 21 - 27  
D-73230 Kirchheim/Teck  
Germany

hereby declares that the control units

**A 550L, A 800 XL**

have been developed, designed and manufactured in conformity with the:

- Machinery Directive 2006/42/EC
- Low Voltage Directive 2014/35/EU
- Electromagnetic Compatibility Directive 2014/30/EU
- RoHS Directive 2011/65/EU

The following standards were applied:

- EN ISO 13849-1, PL "C" Cat. 2 Safety of machines - safety-related parts of controls  
- Part 1: General design guidelines
- EN 60335-1, where applicable Safety of electrical appliances / operators for doors
- EN 61000-6-3 Electromagnetic compatibility (EMC) - interference
- EN 61000-6-2 Electromagnetic compatibility (EMC) - interference resistance
- EN 60335-2-95 General safety requirements for household and similar electrical appliances  
- Part 2: Particular requirements for operators for vertically moving garage  
doors for residential use
- EN 60335-2-103 General safety requirements for household and similar electrical appliances  
- Part 2: Special requirements for operators for gates, doors and windows

The following requirements of Annex 1 of the Machinery Directive 2006/42/EC are met:

1.1.2, 1.1.3, 1.1.5, 1.2.1, 1.2.2, 1.2.3, 1.2.4, 1.2.5, 1.2.6, 1.3.1, 1.3.2, 1.3.4, 1.3.7, 1.5.1, 1.5.4, 1.5.6, 1.5.14, 1.6.1,  
1.6.2, 1.6.3, 1.7.1, 1.7.3, 1.7.4

The special technical documents have been prepared in accordance with Annex VII Part B and are submitted electronically to the regulators on request.

The operator may only be used:

- in combination with door types in the reference list which can be found under certifications.  
[www.sommer.eu](http://www.sommer.eu)

The incomplete machine is intended for installation in a door system only to form a complete machine as defined by the Machinery Directive 2006/42/EC. The door system may only be put into operation after it has been established that the complete system complies with the regulations of the above EC Directive.

The undersigned is responsible for compilation of the technical documents.



Kirchheim/Teck, 20-04-2016

i.V. 

Jochen Lude  
Responsible for documents

# 6. Installation

## 6.1 Important information on installation

Please observe and comply with all instructions to ensure safe installation.

People under the influence of drugs, alcohol, or medications that can influence their ability to react may **not** work on the operator.

The installation of the operator may only be performed by a **qualified specialist**.

This Installation and Operating Manual must be read, understood and complied with by a qualified specialist who installs the operator.



### **DANGER**

**Danger if not observed!**  
If safety instructions are not observed, serious injury or death may result.

- ▶ All safety instructions must be complied with.



### **WARNING**

**Danger of falling!**  
Unsafe or defective ladders may tip and cause serious or fatal accidents.

- ▶ Use only a non-slip, stable ladder.
- ▶ Ensure that ladders are safely positioned.



### **WARNING**

**Danger for trapped persons!**  
Persons may be trapped inside the garage. If trapped persons cannot free themselves, severe injury or death may result.

- ▶ Test the operation of the emergency release regularly from inside and if necessary, also from outside.
- ▶ If there is no second entrance to the garage, you must have a release lock or a Bowden wire for unlocking from the outside installed. This can be used to free persons who cannot free themselves.



### **WARNING**

**Danger due to projecting parts!**  
Door leaves or other parts must not project into roads or public footpaths. This also applies while the door is moving.  
This may cause serious injury or death to persons or animals.

- ▶ Keep public roads and footpaths clear of projecting parts.



### **WARNING**

**Danger due to falling parts of doors!**

If a door is incorrectly balanced, springs may break suddenly. Falling door parts may cause serious injury or death.

Check:

- ▶ the stability of the door.
- ▶ that the door does not bend, rotate or twist when you open or close it.
- ▶ that the door runs smoothly in the tracks.



### **WARNING**

**Danger due to falling ceiling and wall parts!**

The operator cannot be installed correctly if ceiling and walls are unstable or if unsuitable mounting materials are used. Persons or animals may be struck by falling parts of the wall, ceiling or operator. Severe injuries or death may result.

- ▶ You must test the stability of the ceiling and the walls.
- ▶ Use only permissible mounting materials appropriate for the supporting surface.



### **WARNING**

**Danger of entrapment!**  
Loose clothing or long hair may be trapped by moving parts of the door. Severe injuries or death may result.

- ▶ Keep clear of the moving door.
- ▶ Always wear tight-fitting clothing.
- ▶ Wear a hairnet if you have long hair.

## 6. Installation



### **WARNING**

**Danger of crushing and shearing!**  
If the door moves and there are persons or animals in the movement area, **crushing and shearing injuries may be caused by the mechanism and safety edges of the door.**

- ▶ Only use the operator when you have a direct view of the door.
- ▶ All danger zones must be visible during the entire door operation.
- ▶ Always keep the moving door in sight.
- ▶ Keep persons and animals clear of the range of movement of the door.
- ▶ Never put your hand near the door when it is moving or near moving parts. In particular, do not reach into the moving push arm.
- ▶ Do not reach into the ceiling suspension unit when the motor carriage is running along the track.
- ▶ Do not drive through the door until it has opened completely.
- ▶ Never stand under the opened door.



### **WARNING**

**Danger of tripping and falling!**  
Unsafely positioned parts such as packaging, operator parts or tools may cause trips or falls.

- ▶ Keep the installation area free of unnecessary items.
- ▶ Place all parts where no-one is likely to trip or fall over them.
- ▶ The general workplace guidelines must be observed.



### **WARNING**

**Risk of eye injury!**  
Chips flying when drilling may cause serious injuries to eyes and hands.

- ▶ Wear safety glasses when drilling.



### **CAUTION**

**Risk of injury to hands!**  
Rough metal parts may cause abrasions and cuts when picked up or touched.

- ▶ Wear safety gloves when deburring or performing similar work.



### **NOTE**

If the ceiling and walls are not stable, parts of the ceiling and wall or the operator may fall. Objects may be damaged. Ceiling and walls must be stable.



### **NOTE**

To prevent damage to the door or operator, use only approved mounting materials such as wall plugs or screws. The mounting material must match the material of the ceiling and walls. This applies particularly for prefabricated garages.



### **INFORMATION**

Ask your specialist dealer if you require additional installation accessories for different installation or attachment situations.

# 6. Installation

## 6.2 Preparation for installation

Before installation, you must check whether the operator is suitable for the door, see also Chapter "3.7 Technical data".

The operator may only be used:

- in combination with door types in the reference list which can be found at:



<http://som4.me/cgdo>

### Removal of actuation parts



#### WARNING

**Danger of entrapment!**  
Persons or animals may be trapped by straps or cords and pulled into the movement zone of the door. Severe injuries or death may result.

- ▶ Remove straps and cords used for mechanical actuation of the door.

Before installation remove:

- manual locking on door
- all cords or straps necessary to operate the door by hand.

### Disabling mechanical locks



#### NOTE

If locks or other locking systems are installed on a mechanical door, they may block the operator. This may cause faults or damage to the operator. Before the installation of the operator, all mechanical locking systems must be disabled.

The mechanical lock on a door with an operator must be removed or disabled if it is not compatible with the operator.

### Checking the mechanism and weight balance



#### WARNING

**Danger due to falling parts of doors or complete door panels!**  
Wires, spring sets and other fittings can be damaged and break. The complete door panel can fall. Persons or animals may be struck by falling parts of the door or the complete door panel. Severe injuries or death may result.

Before installation, a **qualified specialist** must check and, if necessary, adjust the following:

- ▶ wires, spring sets and other fittings of the door.
- ▶ the weight balance of the door.



#### WARNING

**Danger of entrapment!**  
If the force setting is too high, persons or animals in the movement area of the door may be trapped and pulled along with the door. Severe injuries or death may result.

- ▶ The force setting is relevant to safety and must be carried out by a trained specialist.
- ▶ You must proceed with extreme caution if you check and if necessary adjust the force setting.



#### NOTE

If the weight compensation of the door is incorrectly adjusted, the operator may be damaged.

- The door must be stable.
- It must not bend, rotate or twist when opening and closing.
- The door must move easily in its tracks.

1. Check the mechanisms of the door, such as cables, spring sets and other fittings.

## 6. Installation

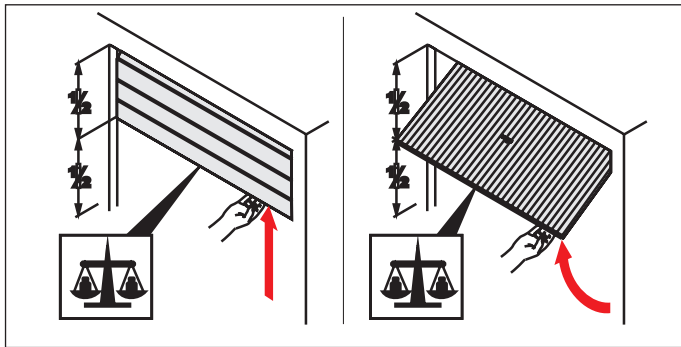

Fig. 2

2. Open the door halfway.
  - ⇒ The door must remain in this position.
  - ⇒ The door must be moved easily by hand and must be balanced.

If the door moves upwards or downwards by itself, the weight balance of the door must be adjusted.

### Emergency release

In a garage without a separate entrance (e.g. wicket doors), the operator's emergency release must be operable from outside. The emergency release must also be routed to be accessible from the outside. This can be done with a Bowden wire or a release lock. Ask your specialist dealer.

### Adjusting the top roll of a sectional door

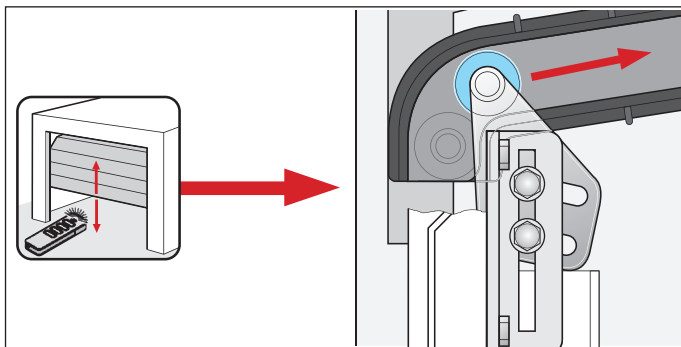

Fig. Top roll on sectional door

If a manually operated sectional door is retrofitted with an operator, the position of the top roll must be checked and adjusted if necessary. The top roll must be routed up over the curve.

### 6.3 Installation of the operator system

The operator may only be installed if the installation requirements and dimensions below are correct.

#### NOTE

Specify the position for mounting the operator on the door. Manually open and close the door several times. The door must be moved easily.

A manual movement force of 150 N is applicable for private garage doors and 260 N for commercial doors.

The value is applicable for the entire life of the door. The door must also be maintained and inspected as specified by the door manufacturer.

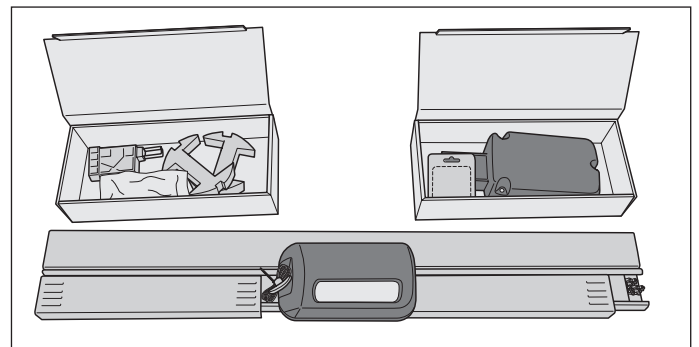

Fig. 1



#### CAUTION

**Risk of injury to hands!**  
Rough metal parts may cause abrasions and cuts when picked up or touched.

- ▶ You must wear safety gloves when working with rough metal parts.



1. Open the package.
  - Place the two cartons in the package beside the tracks and open them.
  - Check the entire contents against the scope of delivery, see chapter "3.5 Scope of delivery".



## 6. Installation

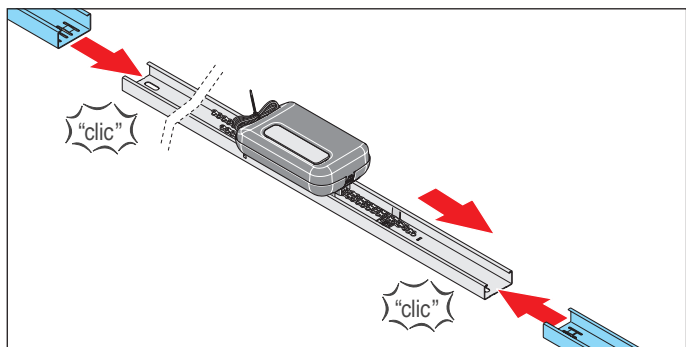

Fig. 2

- Remove the two connecting sleeves beside the motor carriage and attach to the track on the left and right.

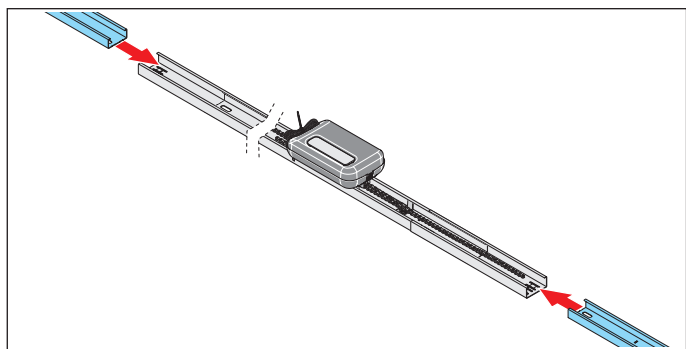

Fig. 3

- Attach a track to each of the connecting sleeves.

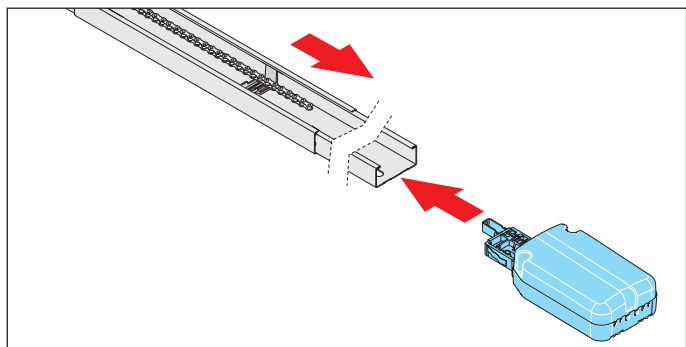

Fig. 4

- Plug in the ceiling control unit to the track behind the limit stop.  
Lay the chain over the limit stop.

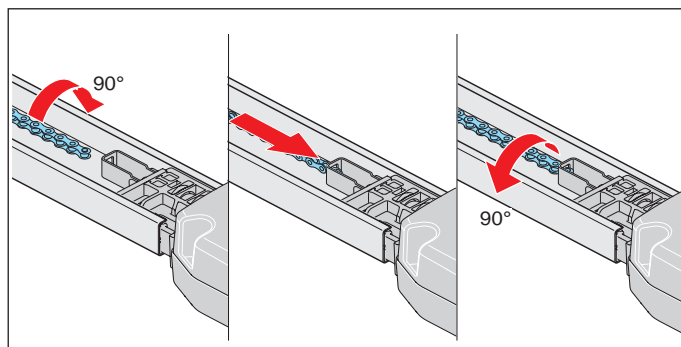

Fig. 5

- Rotate the chain 90° and insert it into the chain holder of the ceiling control unit.  
Rotate the chain back 90°.

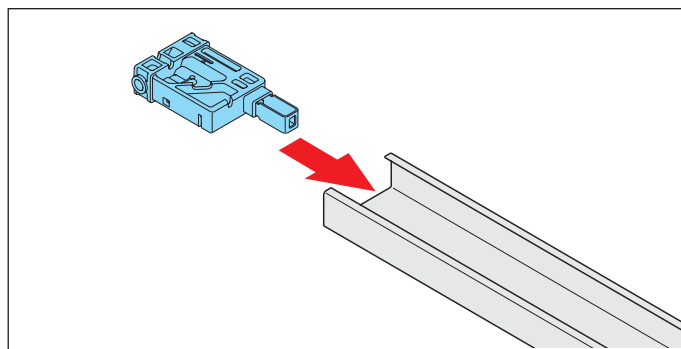

Fig. 6

- Plug the plug-in unit onto the opposite side of the track.

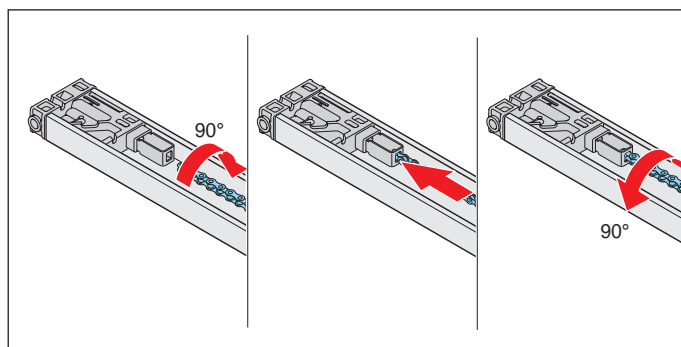

Fig. 7



### NOTE

**The chain must be parallel to the track to prevent damage to the operator.**

- Rotate the chain 90° and insert it into the chain holder of the plug-in unit.  
Rotate the chain back 90°.  
⇒ The entire chain is attached.

## 6. Installation

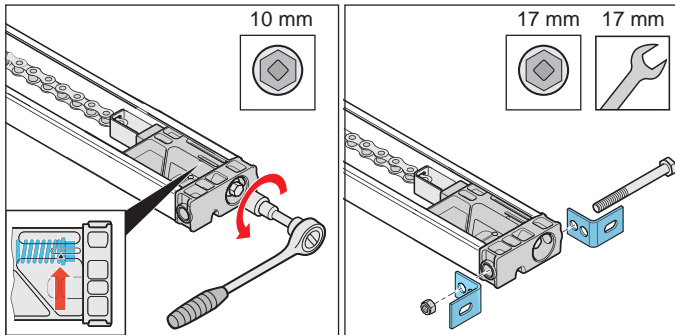

Fig. 8

Fig. 9

8. Tension the chain to the mark on the plug-in unit, see **arrow** in the detailed view.

9. Screw the two header brackets to the plug-in unit with bolt and nut.

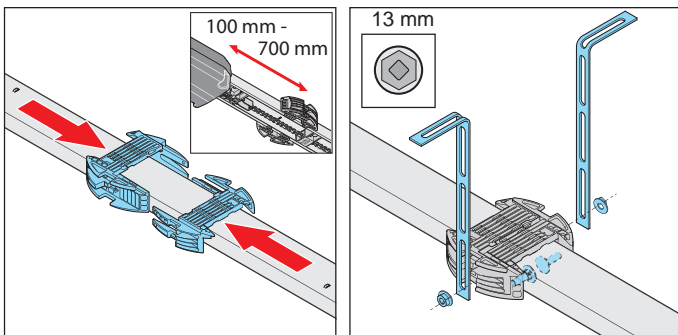

Fig. 10

Fig. 11

10. Turn the track to install the ceiling bracket.

The distance between the ceiling control unit and the ceiling holder should be approx. 100 - 700 mm. Place the ceiling holder on the track and slide into one another.

11. Screw on the perforated strips on the left and right. Also observe the distances for installation to the ceiling or lintel.

⇒ The track is prepared for the remainder of the installation.

For further installation, see Chapter "6.4 Installation on the door".

### 6.4 Installation on the door

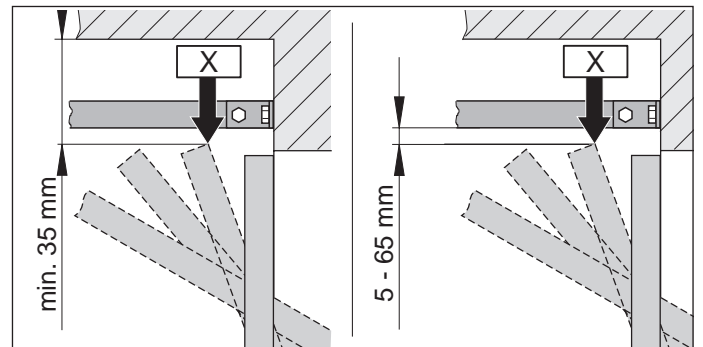

Fig. 1.1 Highest running point for one piece and up-and-over doors

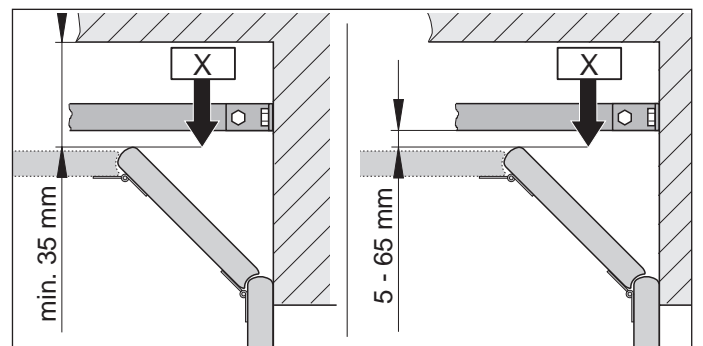

Fig. 1.2 Highest running point for a sectional door



#### INFORMATION

If the distance between the ceiling and the bottom edge of the track is greater than 245 mm, extend the ceiling holder with additional perforated strips.

1. Measure the highest running point of the door "X" depending on the door type:  
Open the door and measure the closest distance (min. 35 mm) between the top edge of the door and the ceiling.  
The distance between "X" and the bottom edge of the track must be at least 5 mm and no more than 65 mm.

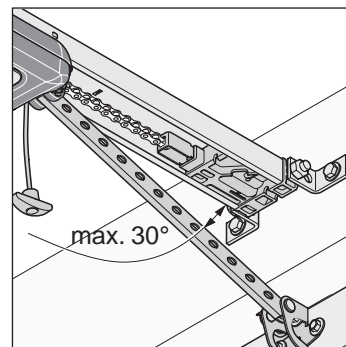

Fig. 2

## 6. Installation



### INFORMATION

The distance may be reduced if a door handle is attached to the middle of the door. The door must be able to run freely.

- The push arm must be at a max. angle of 30° with the door closed.

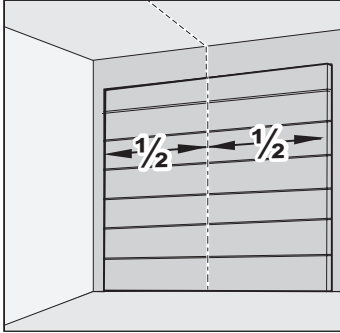

Fig. 3

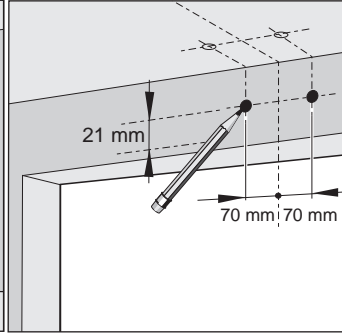

Fig. 4

- Close the door.  
Select the lintel or ceiling for installation. Measure the centre of the door at the front and mark the position on the door and the lintel or ceiling.
- Mark points 70 mm to the right and left of the centre of the door at the same height on the lintel or ceiling.

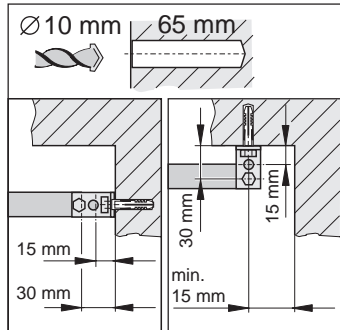

Fig. 5

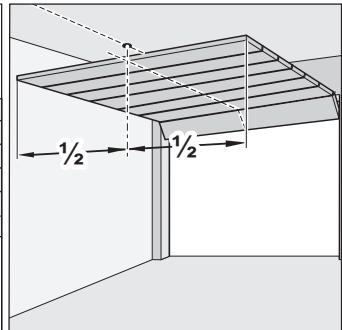

Fig. 6



### NOTE

Cover the operator during drilling to prevent dirt from entering the operator unit and damaging it.



### INFORMATION

If installing on the ceiling, space the drill holes 15 mm apart if possible. This reduces the tilting angle of the mounting bracket.



### INFORMATION

The drilling depth must be considered with respect to the ceiling and wall thickness, particularly with prefabricated garages. It may be necessary to reduce the hole depth.

Only use permissible mounting materials appropriate for the supporting surface.

- Drill two holes (Ø 10 x 65 mm deep) in the ceiling or lintel.
- Open the door.  
Transfer the mark from the centre of the door to the ceiling at the rear.

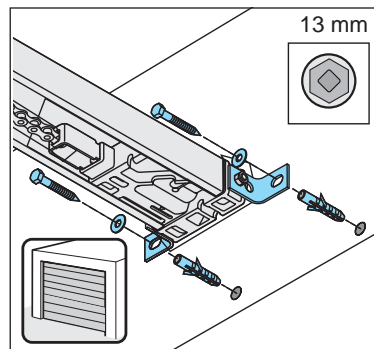

Fig. 7

- Close the door.  
Insert the wall plug into the lintel or ceiling. Lift the track at the front.  
Screw the lintel fitting at the front to the lintel or ceiling with two screws and the washers. Tighten the screws.  
⇒ The track is attached to the lintel or ceiling.

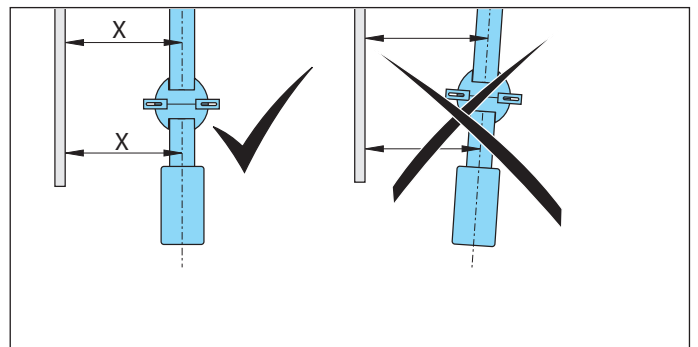

Fig. 8

- Align the operator parallel to the tracks of the door.

## 6. Installation

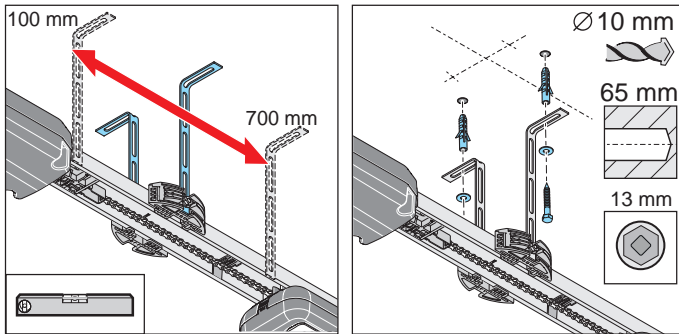

Fig. 9

Fig. 10

9. Align the track parallel to centre of the door at the rear.  
Align the ceiling bracket.  
The distance between the ceiling control unit and the ceiling holder should be approx. 100 - 700 mm.  
The ceiling bracket should be installed between them.  
Check the alignment of the track with a spirit level if necessary.
10. Mark the holes for the ceiling holder on the ceiling.  
Drill two holes (Ø 10 x 65 mm deep).  
Insert the wall plugs.  
Insert two screws with washers and screw the perforated strip to the ceiling.  
Tighten the screws.  
⇒ The track is attached to the ceiling.

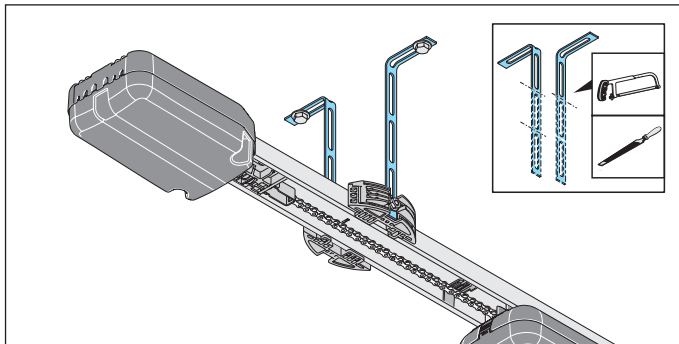

Fig. 11



**CAUTION**  
**Risk of injury to hands!**  
Rough metal parts may cause abrasions and cuts when picked up or touched.

- ▶ The projecting perforated strips must be sawn off and deburred to prevent injury.
- ▶ Wear safety gloves when deburring.

11. The projecting perforated strips must be shortened.

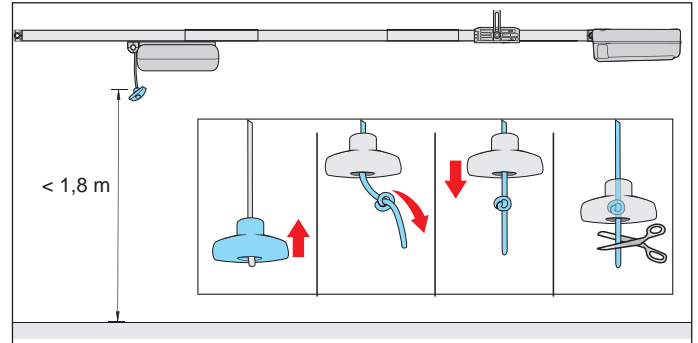

Fig. 12



### WARNING

**Danger of entrapment!**  
Persons or animals in the movement area of the door may be trapped in a loop of the emergency release cord and the door may be accidentally unlocked. Severe injuries or death may result.

- ▶ The emergency release handle which is included must be used.



### NOTE

The emergency release handle may cause damage, e.g. scratches on the vehicle.  
The distance between the garage floor and the emergency release cord must be less than 1.8 m.  
The emergency release handle must be at least 50 mm from moving and fixed parts throughout its complete travel path.

12. Attach the emergency release handle:  
Thread the cord through the emergency release handle. Tie a double knot in the cord at an appropriate point. Pull the emergency release handle over the double knot. If necessary, shorten the cord or lengthen it with suitable materials.

## 6. Installation

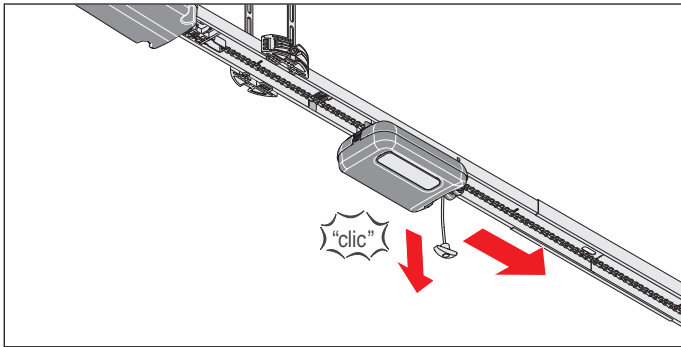

Fig. 13

13. Pull the emergency release cord once to unlock the motor carriage.  
Slide the motor carriage forward to the door.

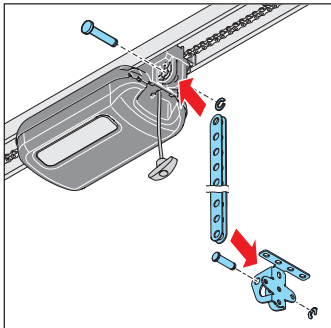

Fig. 14

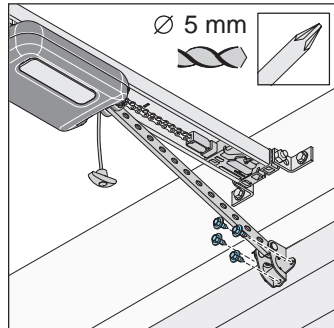

Fig. 15



### WARNING

**Risk of injury in the head region!**  
Impact with suspended objects may cause serious abrasions and cuts.



- ▶ You must wear a safety helmet when installing suspended parts.

14. Plug the push arm into the door bracket. Insert the bolt and slide on the safety bolt.  
Plug the push arm into the motor carriage at the front. Also insert the bolt and slide on the safety bolt.

15. Align the door bracket with the centre of the door. Mark the position of the holes and drill them ( $\varnothing$  5 mm).

Fix the door bracket to the door with the hexagon bolts.

⇒ The push arm is attached to the motor carriage and the door.

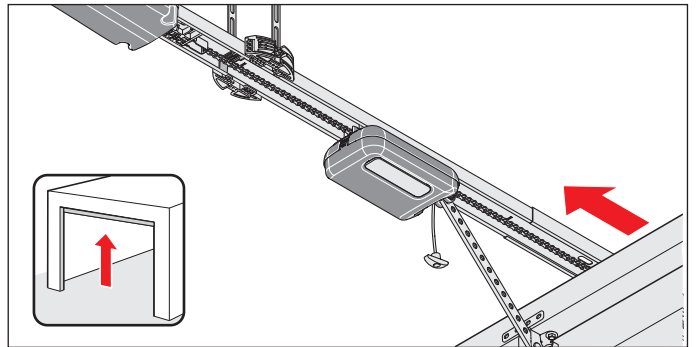

Fig. 16



### NOTE

**The door must not rub against the operator or tracks. This could damage the operator or tracks.  
The operator must be offset.**

16. Open the door completely by hand.

If the door rubs against the operator or the tracks, the operator must be offset.

⇒ The limit stop moves automatically with the motor carriage.

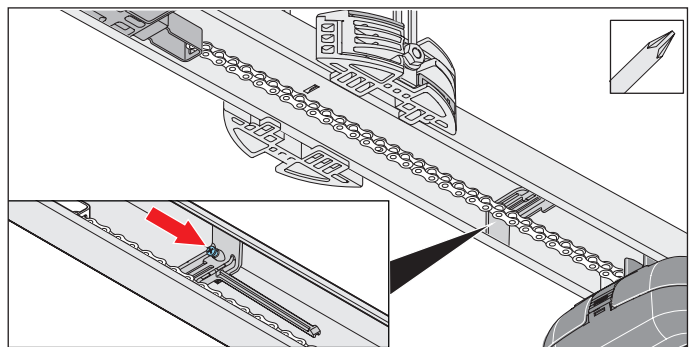

Fig. 17



### NOTE

**Do not push the door all the way to the mechanical stop. This is because otherwise, the operator will pull the door against the mechanical stop. This will apply tension to the door and it may be damaged.  
A clearance of 30 mm is required.**

## 6. Installation



### INFORMATION

The limit stop can be subsequently pushed under the chain and screwed into the track. Then screw the limit stop tightly to the track at the respective spot.

17. Tighten the screw on the limit stop with a Phillips screwdriver without changing its position.  
Check the door OPEN end position:  
Open the door fully for this. The motor carriage moves against the limit stop to the door OPEN end position until a click noise is heard.  
⇒ The door OPEN end position is set.

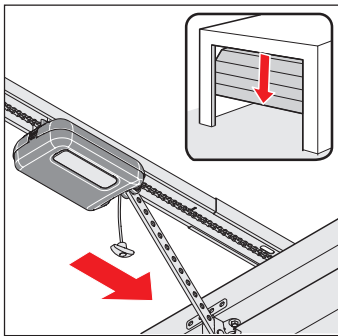

Fig. 18

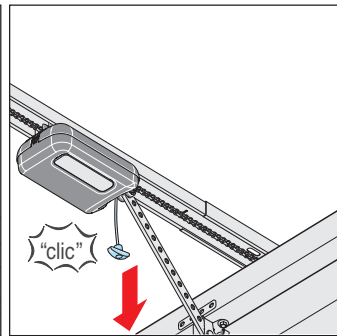

Fig. 19



### NOTE

In the case of an emergency release, the door could independently open or close itself due to a broken spring or incorrect setting of the weight balancing. The operator could be damaged or destroyed. Check the emergency release regularly.



### INFORMATION

It can be locked and released in any door position.

18. Move door to centre position.  
⇒ The motor carriage moves with it.
19. Pull the emergency release cord.  
⇒ **The motor carriage is locked.**  
⇒ The door can only be moved by the operator.
20. Check to make sure that no part of the door projects into public footpaths or roads.



### WARNING

**Danger due to projecting parts!**  
Parts must not project into public roads or footpaths. This also applies while the door is moving. Persons and animals may be seriously injured.

- Keep public roads and footpaths clear of projecting parts.

⇒ Installation of the operator is complete.

# 7. Removing and fastening covers

## 7.1 Cover of the motor carriage

Observe in particular the following safety instructions for this chapter.



### **WARNING**

**Danger due to optical radiation!** Looking into an LED at short range for an extended period may cause optical glare. This may temporarily reduce vision. This may cause serious or fatal accidents.

- ▶ Never look directly into an LED.



### **WARNING**

**Danger due to hot surfaces!** After frequent operation, parts of the motor carriage or the control unit may become hot. If the cover is removed and hot parts are touched, they may cause burns.

- ▶ Allow the operator to cool down before removing the cover.

### Removing the cover

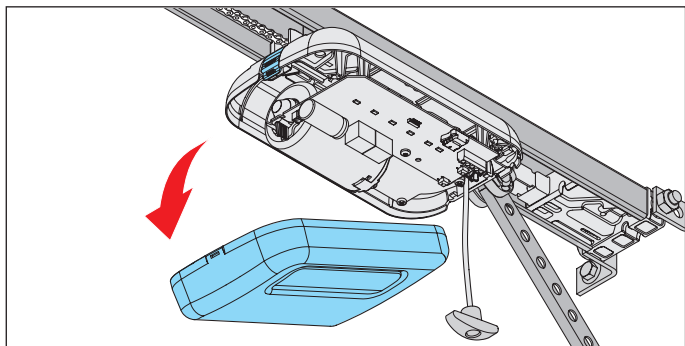

Fig. 1

1. Press on the cover lock at the back of the motor carriage and remove the cover.

### Installing the cover

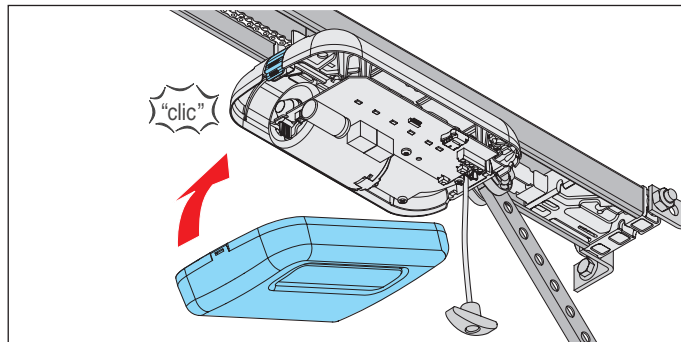

Fig. 1

1. Insert the cover from the front and lock it to the motor carriage at the back.

# 7. Removing and fastening covers

## 7.2 Cover of the ceiling control unit

Observe in particular the following safety instructions for this chapter.



### **DANGER**

**Danger due to electric current!**  
Contact with live parts may result in electric current flowing through the body. Electric shock, burns or death will result.

- ▶ All work on electrical components must be carried out by a **trained electrician**.
- ▶ Disconnect the mains plug before working on the operator.
- ▶ If an accumulator is connected, disconnect it from the control unit.
- ▶ Check that the operator is not live.
- ▶ Secure the operator against being switched back on.



### **WARNING**

**Danger due to hot surfaces!**  
After frequent operation, parts of the motor carriage or the control unit may become hot. If the cover is removed and hot parts are touched, they may cause burns.

- ▶ Allow the operator to cool down before removing the cover.

### Unscrewing cover

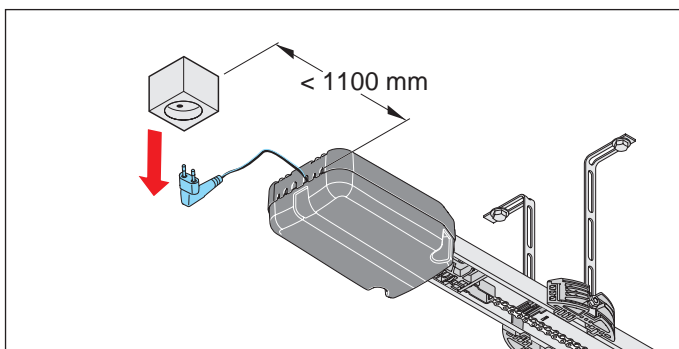

Fig. 1

1. Disconnect the operator from the mains voltage. Check it is disconnected from the power supply.

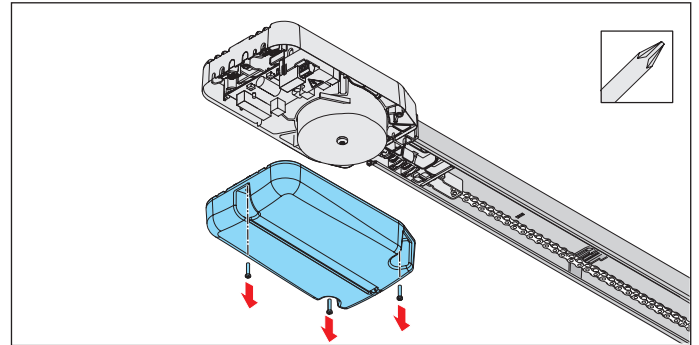

Fig. 2



### **NOTE**

**If there is an accumulator in the cover of the ceiling control unit, remove the cover carefully. The accumulator is loose in the cover. Disconnect the accumulator plug from the circuit board.**

2. Unscrew and remove the cover from the ceiling control unit.

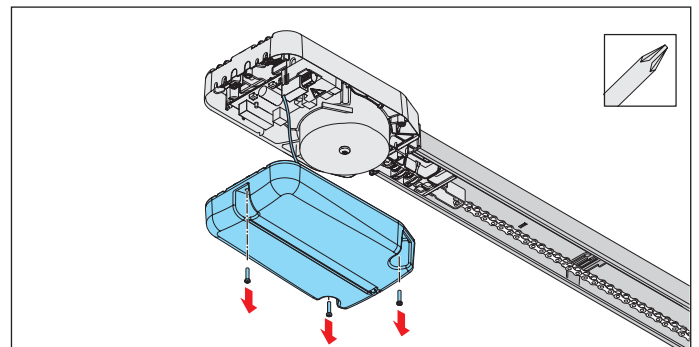

Fig. 3

3. If an accumulator is used, unscrew the cover carefully. Disconnect the accumulator from the circuit board. Remove the cover with the disconnected accumulator, see Chapter "11.11 Installing and removing the accumulator".

### Installing the cover

1. After working on the ceiling control unit replace the cover in reverse order.
2. Connect the operator to the mains voltage. Check that the power supply is connected.  
⇒ The operator is supplied with mains voltage.



# 8. Electrical connection

## 8.1 Connection to a power outlet

A power outlet is required for the electrical connection of the operator.

A power outlet must be installed by a **trained electrician**. The power outlet must be protected by a fuse. Local and national installation regulations (e.g. VDE) must be observed.

People under the influence of drugs, alcohol, or medications that can influence their ability to react may **not** work on the operator.

Observe in particular the following safety instructions for this chapter.



### **DANGER**

**Danger due to electric current! Contact with live parts may result in electric current flowing through the body. Electric shock, burns or death will result.**

- ▶ All work on electrical components must be carried out by a **trained electrician**.
- ▶ Before inserting the mains power plug for the first time, ensure that the voltage of the power source matches the voltage listed on the operator type plate.
- ▶ Do not connect the power supply until installation is complete.
- ▶ Disconnect the mains plug before working on the operator.
- ▶ If an accumulator is connected, disconnect it from the control unit.
- ▶ Check that the operator is not live.
- ▶ Secure the operator against being switched back on.

### **NOTE**

**Do not connect the ceiling control unit to the power supply until the installation is complete to prevent damage to the operator.**

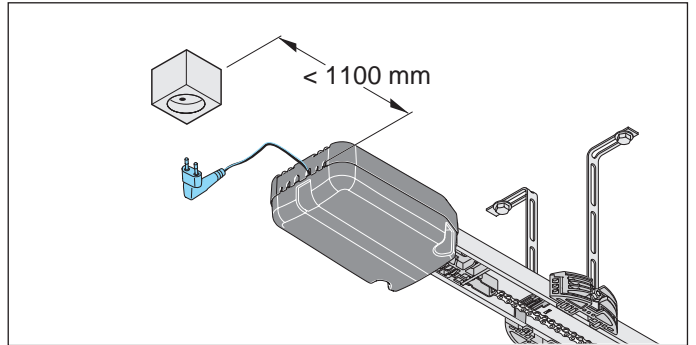

Fig. Distance between ceiling control unit and power outlet  
Note that the distance between the ceiling control unit and the power outlet must not exceed 1.1 m.



### **INFORMATION**

The power outlet must be installed as follows:

- within easy reach of the ceiling control unit power cable
- easily visible and clear of obstacles



### **INFORMATION**

The power cable is approx. 1.2 m long.



### **INFORMATION**

The power cord that has been provided must not be shortened or extended. All devices to be connected externally must have safe isolation of the contacts from the mains voltage supply in accordance with IEC 60364-4-41. Wiring for external devices must be installed in accordance with IEC 60364-4-41. All electrical wiring must be firmly secured to prevent displacement.

# 9. Initial operation

## 9.1 Safety information for initial operation

Observe in particular the following safety instructions for this chapter.



### **WARNING**

**Danger of entrapment!**  
Persons or animals in the movement area of the door may be trapped and pulled along with the door. Severe injuries or death may result.

- ▶ Keep clear of the moving door.
- ▶ Always wear tight-fitting clothing.
- ▶ Wear a hairnet if you have long hair.



### **WARNING**

**Danger of crushing and shearing!**  
If the door moves and there are persons or animals in the movement area, crushing and shearing injuries may be caused by the mechanism and safety edges of the door.

- ▶ Only use the operator when you have a direct view of the door.
- ▶ All danger zones must be visible during the entire door operation.
- ▶ Always keep the moving door in sight.
- ▶ Keep persons and animals clear of the range of movement of the door.
- ▶ Never put your hand near the door when it is moving or near moving parts. In particular, do not reach into the moving push arm.
- ▶ Do not reach into the ceiling suspension unit when the motor carriage is running along the track.
- ▶ Do not drive through the door until it has opened completely.
- ▶ Never stand under the opened door.



### **WARNING**

**Danger due to optical radiation!**  
Looking into an LED at short range for an extended period may cause optical glare. This may temporarily reduce vision. This may cause serious or fatal accidents.

- ▶ Never look directly into an LED.



### **NOTE**

Objects in the movement area of the door may be jammed and damaged. Objects must not be in the range of movement of the door.



### **INFORMATION**

The control unit detects a short-circuit between chain and track and then switches the operator off.



### **INFORMATION**

If a photocell is used, it must not be actuated when starting the programming. If a photocell is used as a frame photocell, move the door to the centre position.

# 9. Initial operation

## 9.2 Initial operation

**Before initial operation**, read this chapter with special care to ensure that you can make the adjustments to the operator safely and optimally.



### **WARNING**

**Danger of entrapment!**  
If the force setting is too high, persons or animals in the movement area of the door may be trapped and pulled along with the door. Severe injuries or death may result.

- ▶ The force setting is relevant to safety and must be carried out by a trained specialist.
- ▶ You must proceed with extreme caution if you check and if necessary adjust the force setting.
- ▶ Please note that the operator may only be operated if a non-hazardous force value has been set.
- ▶ Select the force setting low enough to eliminate any danger of injury by the closing force.



### **NOTE**

Do not use a metal object to set the DIP switches, because this may damage the DIP switches or the circuit board. Use a suitable tool to set the DIP switches, such as a flat, thin plastic object.



### **INFORMATION**

The force setting must be checked after installation of the operator. See also chapter "13.1 Testing obstacle detection".

The operator may only be used:

- in combination with door types in the reference list which can be found at:



<http://som4.me/cgdo>

For compliance with EN 13241-1, before initial operation, the door type must be selected and set on the motor carriage with the DIP switch.

The factory setting of the DIP switches is OFF, which is then applicable for sectional doors.

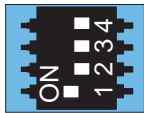
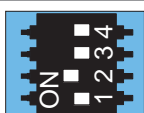
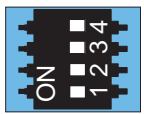
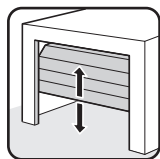
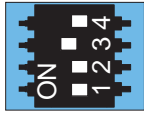
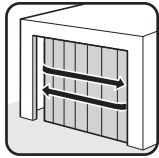
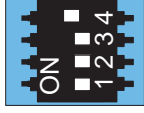
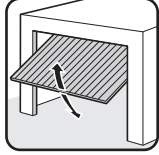
DIP switch on motor carriage	ON	OFF 
1 	• Automatic closing function activated	• Automatic closing function deactivated
2 	• Partial opening activated/ lighting function deactivated	• Partial opening deactivated/ lighting function activated
3+4 		
3 		
4 		

The motor carriage has an automatic force setting. The motor carriage memorises the required force during the door OPEN and CLOSE movements and stores it when the end position has been reached.



### **INFORMATION**

**During initial operation;**

- Stay in the garage, particularly when programming.
- Obstacle detection is not yet coordinated to the door and is in the programming phase.



### **INFORMATION**

Programming can be carried out via a handheld transmitter or an external button.

## 9. Initial operation



### INFORMATION

The operating forces can be modified and adjusted with SOMlink and a WiFi-enabled device.

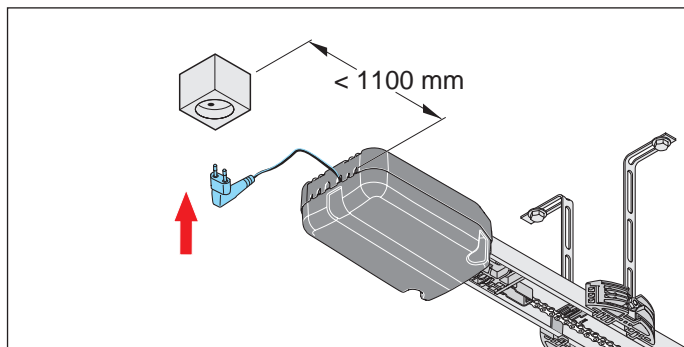

Fig. 1

1. Compare the existing power supply with the type plate.  
Connect the operator to the mains voltage.  
⇒ The status LED of the motor carriage flashes green.

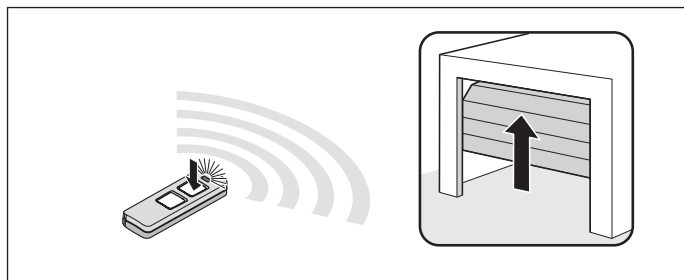

Fig. 2

2. After the operator has been connected to the power supply, its first movement after a pulse is always door OPEN.  
**Briefly** press button 1 on the preprogrammed handheld transmitter. See also the separate instructions for the "**Handheld transmitter**".  
⇒ The motor carriage moves slowly to the door OPEN end position and **automatically** switches off at the guide idler.  
⇒ The operator lighting flashes.

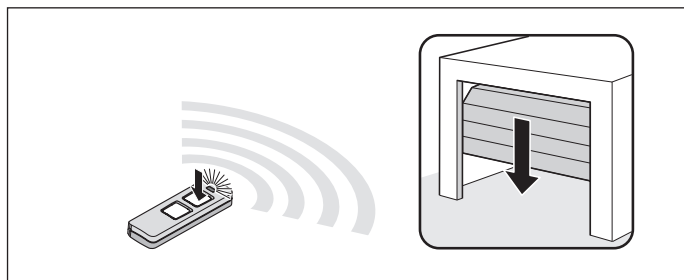

Fig. 3

3. Press button 1 on the handheld transmitter again **briefly**.  
⇒ The motor carriage moves slowly in the door CLOSE direction.  
⇒ The operator lighting flashes.  
The motor carriage switches off **automatically** when it reaches the factory-set closing force at the door CLOSE end position.  
⇒ The operator lighting flashes in a different sequence.

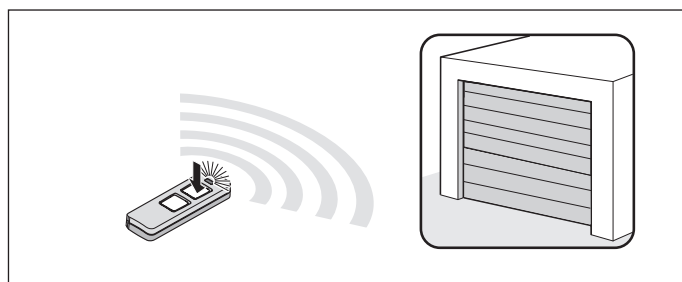

Fig. 4

4. Press button 1 on the handheld transmitter **briefly** (< 1 second) to save the end position.  
⇒ The operator lighting flashes briefly in a fast sequence.

### The operator automatically starts its programming process:

- ⇒ The motor carriage moves **automatically** to the door OPEN end position again and programs the required operating force.
- ⇒ The motor carriage **automatically** moves to the door CLOSE end position.  
If necessary, the motor carriage moves over the path several times for programming with a greater door weight.
- ⇒ The motor carriage **automatically** moves briefly in the door OPEN direction to program the soft run.
- ⇒ The door **automatically** returns to the door CLOSE end position.
- ⇒ The motor carriage **automatically** moves to the door OPEN end position.
- ⇒ The LEDs of the operator lighting remain **steady**.
- ⇒ **Operator is programmed and ready for use.**



### INFORMATION

The motor carriage stops if the door is difficult to move. The door mechanism must be checked, see Chapter "9.3 Detecting obstacles during the force programming run."

It may be necessary to adjust the end positions; see Chapter "9.4 Mechanical adjustment of the end positions".

## 9. Initial operation

### 9.3 Detecting obstacles during the force programming run

If the door detects an obstacle during its first door CLOSE movement and the force programming runs cannot be completed, the door stops.

#### NOTE

Check the travel path, mechanism, spring tension and the weight balance to prevent damage to the door system.

1. **Press and hold** button 1 on the handheld transmitter.  
⇒ The motor carriage **moves briefly** and then moves continuously in the door CLOSE direction until the desired end position has been reached.
  2. Release button 1 on the handheld transmitter.
  3. **Fine adjustment:**  
Press and hold button 1 on the handheld transmitter until the motor carriage **moves briefly**.  
Release button 1 on the handheld transmitter.
    - 3.1 The process can be repeated until the desired end position is reached.  
Press button 1 on the handheld transmitter **briefly** (< 1 second) to save the door CLOSE end position.  
⇒ The motor carriage starts the **automatic** force programming run to the door OPEN end position.  
⇒ The door starts the **automatic** force programming run for the door CLOSE end position.
- If an obstacle is detected again, the motor carriage stops and reverses a short distance.
1. **Press and hold** button 1 on the handheld transmitter.  
⇒ The motor carriage starts without jerking, because the end position of the door is already saved.  
⇒ The motor carriage moves to the end position.
  2. Release button 1 on the handheld transmitter.
  3. Press button 1 on the handheld transmitter briefly.  
⇒ **Automatic force programming runs start again.**  
⇒ On completion of the force programming runs, the motor carriage **automatically** moves to the door OPEN end position.  
⇒ The LEDs of the operator lighting remain **steady**.  
⇒ **Operator is programmed and ready for use.**

### 9.4 Mechanical adjustment of the end positions

#### Increasing the closing pressure of the end position for door CLOSE

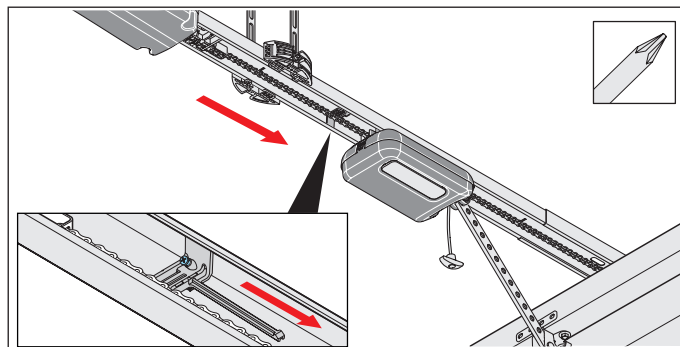

Fig. 1

1. Loosen the screw on the limit stop and move the limit stop a few millimetres towards door CLOSE. Tighten the screw again.
2. The function of the emergency release must be checked in the door CLOSE end position. Unlocking must be possible.

#### Reducing the closing pressure of the end position for door CLOSE

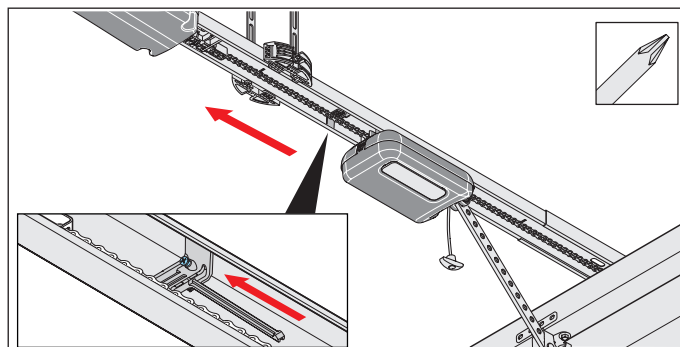

Fig. 1

1. Loosen the screw on the guide idler and move the guide idler a few millimetres towards door OPEN. Tighten the screw again.

#### NOTE

Do not push the door all the way to the mechanical stop. This is because otherwise, the operator will pull the door against the mechanical stop. This will apply tension to the door and it may be damaged.  
A clearance of 30 mm is required.

## 9. Initial operation

### 9.5 Attaching information sign and warning signs

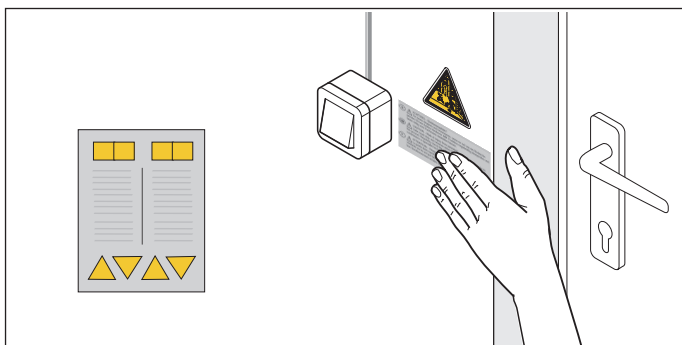

Fig. 1.1 Attach sticker near the stationary control or control unit



Fig. 1.2 Sticker on door panel

1. Attach the warning signs and information sign at a cleaned and grease-free point:
  - far from moving parts
  - near the stationary control or control unit
  - at eye level at a highly visible section of the door leaf
2. Carry out obstacle detection, see Chapter "13.1 Testing obstacle detection".  
⇒ **Initial operation is complete.**

# 10. Connections and special functions of the motor carriage

## 10.1 Motor carriage circuit board

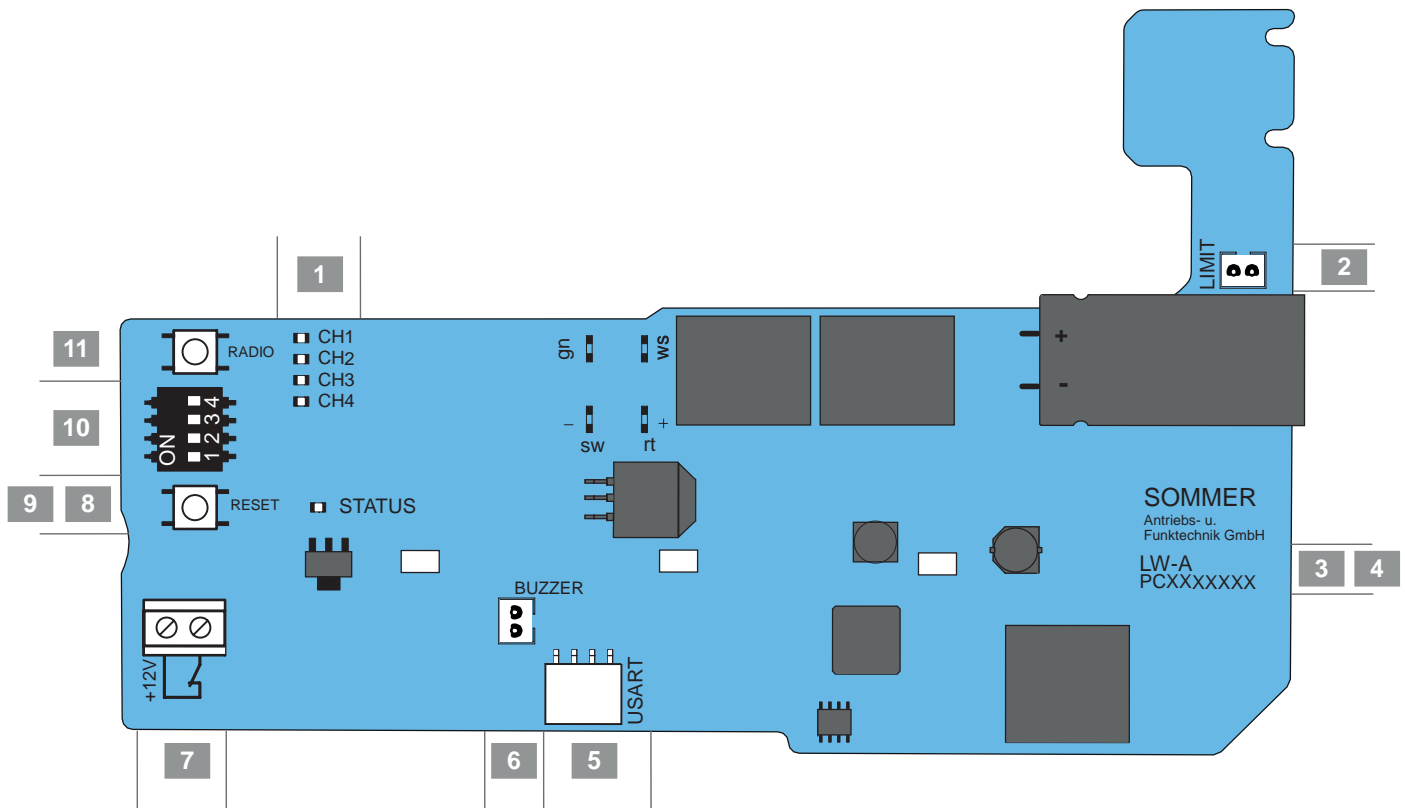

Fig. Motor carriage circuit board (complete version\*)

### Connection options on the motor carriage

1. LED, CH 1 - CH 4, red Display for radio channel	7. Terminal for wicket door safety device Potential-free
2. LIMIT slot, blue Limit switch terminal (OPEN)	8. Status LED, green
3. Circuit board label	9. Reset button, green
4. LEDs, operator lighting	10. DIP switches
5. USART slot Interface	11. Radio button, red (radio)
6. BUZZER slot, black Warning or alarm buzzer terminal	

\*The version can vary depending on the type. This means the use of accessories can vary.

A connection diagram can be found in Chapter "19. Connection diagrams and functions of the DIP switches for A 550 L and A 800 XL".

# 10. Connections and special functions of the motor carriage

## 10.2 Connection options on the motor carriage

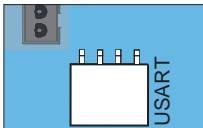
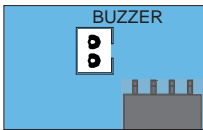
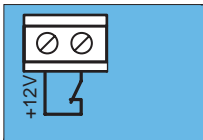
Circuit board section	Function/ application example
	<b>USART slot</b> Terminal, e.g. home automation module
	<b>BUZZER slot, black</b> Terminal for warning or alarm buzzer
	<b>Wicket door safety device terminal</b> (wicket door switch, reed contact etc.)  Potential-free Contact command (12 V, 10 mA) normally closed contact

\*The version can vary depending on the type. This means the use of accessories can vary.

For more information on the accessories, contact your specialist dealer or see:

[www.sommer.eu](http://www.sommer.eu)

Observe in particular the following safety instructions for this chapter.



**⚠ DANGER**

**Danger due to electric current!**  
Contact with live parts may result in electric current flowing through the body. Electric shock, burns or death will result.

- ▶ All work on electrical components must be carried out by a **trained electrician**.
- ▶ Do not connect accessories unless the operator is disconnected from the power supply.
- ▶ Disconnect the mains plug before working on the operator.
- ▶ If an accumulator is connected, disconnect it from the control unit.
- ▶ Check that the operator is not live.
- ▶ Secure the operator against being switched back on.

## 10.3 Reducing the illumination power of LEDs



### ⚠ WARNING

**Danger due to optical radiation!**  
Looking into an LED at short range for an extended period may cause optical glare. This may temporarily reduce vision. This may cause serious or fatal accidents.

▶ Never look directly into an LED.

The illumination power of the LEDs can be reduced during adjustment work by pressing the reset button or radio button once briefly.

1. Press the Radio or Reset button once briefly.  
⇒ Illumination power of LEDs reduced.

## 10.4 Explanation of the radio channels

LED	Radio channel	Setting/function
1	CH 1	Pulse mode
2	CH 2	Partial opening or lighting function
3	CH 3	Defined OPEN
4	CH 4	Defined CLOSE



# 10. Connections and special functions of the motor carriage

## 10.5 Programming the transmitter

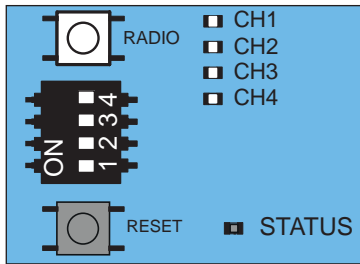

Fig. 1



### INFORMATION

If no transmission command is received within 30 seconds of pressing the radio button, the radio receiver switches to normal mode.

1. Press the radio button repeatedly to select the required radio channel.

LED	1 x	2 x	3 x	4x
CH 1				
CH 2				
CH 3				
CH 4				

2. Press the desired button on the transmitter until the previously selected LED (CH 1, CH 2, CH 3, CH 4) goes out.

⇒ LED goes out - programming is complete.  
 ⇒ The transmitter has transferred the radio code to the radio receiver.

3. Repeat the above steps to program additional transmitters.



### INFORMATION

Further transmitters cannot be programmed if all memory positions of the handheld transmitter are occupied.

### If the memory capacity has been reached

A total of 20 handheld transmitter commands are available for all channels. If an attempt is made to program additional transmitters, the red LEDs of radio channels CH 1 - CH 4 flash. Delete unused handheld transmitter commands to program new commands.

## 10.6 Cancelling programming mode

1. Press the radio button until all LEDs are out or make no input for 10 seconds.  
 ⇒ Programming mode is cancelled.

## 10.7 Deleting a transmitter button from the radio channel

1. Press the Radio button repeatedly to select the required radio channel.  
 Press and hold the radio button for 15 seconds.

LED	1 x	2 x	3 x	4x
CH 1				
CH 2				
CH 3				
CH 4				

⇒ The LED blinks after 15 seconds.

2. Release the Radio button.  
 ⇒ The radio receiver is now in deletion mode.
3. Press the transmitter button for which the command is to be deleted in the radio channel.

⇒ LED goes out.  
 ⇒ The deletion procedure is ended.

Repeat the process for additional buttons as required.

## 10.8 Deleting transmitter completely from the receiver

1. Press and hold the radio button for 20 seconds.  
 ⇒ The LED flashes after 15 seconds.  
 ⇒ After another 5 seconds, the flash sequence changes to flashing.
2. Release the Radio button.  
 ⇒ The radio receiver is now in deletion mode.
3. Press any button on the transmitter that is to be deleted.  
 ⇒ LED goes out.  
 ⇒ The deletion procedure has been completed.  
 ⇒ The transmitter is deleted from the radio receiver.

Repeat the process for additional transmitters as required.

# 10. Connections and special functions of the motor carriage

## 10.9 Deleting radio channel in the receiver

- Press the Radio button repeatedly to select the required radio channel.  
Press and hold the Radio button for 25 seconds.

LED	1 x	2 x	3 x	4x
CH 1				
CH 2				
CH 3				
CH 4				

- ⇒ The LED blinks after 15 seconds.
  - ⇒ After another 5 seconds, the flash sequence changes to flashing.
  - ⇒ After another 5 seconds, the LED of the selected radio channel remains steady.
- Release the Radio button.
    - ⇒ The deletion procedure is ended.
    - ⇒ All programmed transmitters on the selected radio channel are deleted from the radio receiver.

## 10.10 Deleting all radio channels in the receiver

- Press and hold the Radio button for 30 seconds.
  - ⇒ The LED blinks after 15 seconds.
  - ⇒ After another 5 seconds, the flash sequence changes to flashing.
  - ⇒ After another 5 seconds, the LED of the selected radio channel remains steady.
  - ⇒ After another 5 seconds, all LEDs light up.
- Release the Radio button.
  - ⇒ All LEDs are off after 5 seconds.
  - ⇒ **All programmed transmitters are deleted from the receiver.**
  - ⇒ Receiver is completely deleted; this also applies if the Memo is plugged in.

## 10.11 Resetting the control unit

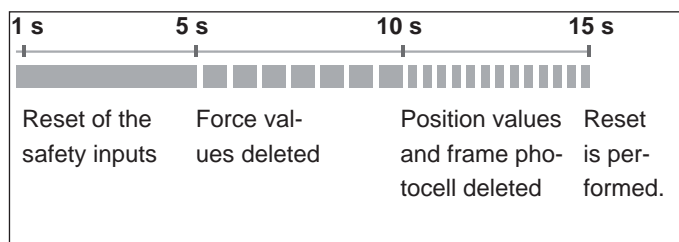

Fig. Overview of the time sequence of the motor carriage status LED when pressing the green Reset button

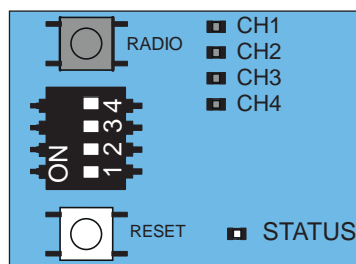

Fig. 1



### INFORMATION

A SOMlink and a WiFi-enabled device are required to reset all parameters to the factory setting.



### Resetting the safety devices

- Press the green Reset button for 1 second.
  - ⇒ Reset of the connected safety devices.
  - ⇒ Subsequently attached safety inputs are detected.

### Deleting the force values

- Press the green Reset button on the motor carriage for 5 seconds until the green status LED flashes slowly.
  - ⇒ Force values are deleted.

### Deleting force and position values

- Press the green Reset button on the motor carriage for 10 seconds until the green status LED flashes quickly.
  - ⇒ Force and position values deleted.
  - ⇒ Frame photocell deleted.

# 10. Connections and special functions of the motor carriage

## Resetting

1. Press the green Reset button on the motor carriage for 15 seconds until the green LED goes out.  
⇒ Reset is performed.

## 10.12 Setting the DIP switches on the motor carriage

Special functions can be set with the DIP switches on the motor carriage. For compliance with EN 13241-1, before initial operation, the door type must be selected and set on the motor carriage with the DIP switch. The factory setting of the DIP switches is OFF, which is then applicable for sectional doors.

### NOTE

Do not use a metal object to set the DIP switches, because this may damage the DIP switches or the circuit board. Use a suitable tool to set the DIP switches, for example a flat, thin plastic object.

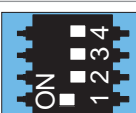
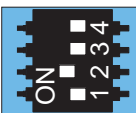
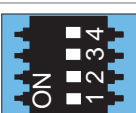
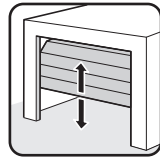
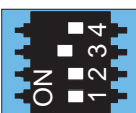
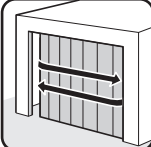
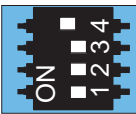
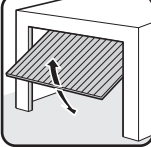
DIP switches on the motor carriage	ON	OFF 
1 	• Automatic closing function activated	• Automatic closing function deactivated
2 	• Partial opening activated/ lighting function deactivated	• Partial opening deactivated/ lighting function activated
3+4 		
3 		
4 		

## 10.13 Setting automatic closing function - defining basic values

When automatic closing is activated, the door is opened by a pulse.

The door moves to the door OPEN end position.

The door closes automatically after the hold open time. With the factory settings, the door also closes automatically from the partial opening position when the automatic closing function is activated.



### WARNING

#### Risk of injury during automatic closing!

Automatically closing doors can injure people or animals in the movement area of the door when the door is closing. This may cause serious or fatal injury.

- ▶ Always keep the moving door in sight.
- ▶ Keep persons and animals clear of the range of movement of the door.
- ▶ Never put your hand near the door or near moving parts when the door is moving. In particular, do not reach into the ceiling holder or the push arm.
- ▶ Do not drive through the door until it has opened completely.

### NOTE

If the door is not in view and the operator is actuated, objects in the movement area of the door may be jammed and damaged. Objects must not be in the range of movement of the door.



### INFORMATION

The door opens completely if it hits an obstacle.



### INFORMATION

Operation with automatic closing must comply with EN 12453. This is a legal requirement. National regulations must be observed in non-European countries. A photocell must be connected. Bridging the safety inputs with jumpers is not permitted.

# 10. Connections and special functions of the motor carriage

1. Close the door.
2. Set DIP switch 1 to "ON."
3. The pre-set hold open time of the door is 30 seconds.  
Every new command within these 30 seconds restarts the hold open time. Pressing button 1 on the transmitter causes the door to move into the OPEN position.  
The door movement cannot be stopped with the transmitter.
4. The door closes automatically after 30 seconds.  
The closing movement can be stopped by a command with the transmitter.  
⇒ Door opens completely - after reversal of direction.
5. The door starts the closing process again after 30 seconds.  
⇒ Door in door CLOSE end position.



## INFORMATION

The factory setting is fully automatic closing with a pre-set hold open time of 30 seconds from the door OPEN end position and 60 seconds from partial opening. The hold open time starts at the door OPEN end position and from partial opening.

When driving through, the photocell is activated and the hold open time is shortened to 5 seconds.

This setting and the selection of semi-automatic closing can be adjusted via SOMlink and a WiFi-enabled device.



## INFORMATION

The pre-warning time can be activated and adjusted via SOMlink and a WiFi-enabled device.



The progress of the pre-warning time is displayed by the flashing operator lighting and the warning light.

## 10.14 Setting the lighting function

The operator lighting on the motor carriage can be switched on and off separately via radio channel CH 2. This function is pre-set in the factory settings. Program the desired handheld transmitter button to radio channel CH 2.

The factory setting of DIP switch 2 is OFF, and the lighting function is therefore activated.



## INFORMATION

The lighting function or partial opening can be operated.

1. Set DIP switch 2 on the motor carriage to "OFF."
2. Press the Radio button repeatedly to select the radio channel CH 2. Programme the lighting function on the desired transmitter button.  
⇒ The lighting function is available.

The operator lighting on the motor carriage can be switched on and off with the transmitter button.



## INFORMATION

If the operator lighting is not switched off manually, it switches off automatically after 60 minutes. This value can be changed via SOMlink and a WiFi-enabled device.



Other lights and functions are available with the Lumi base+ and the Relay accessories. The Lumi base+ is an LED strip with 12 LEDs (24V, 7W). It can be attached to the ceiling control unit as supplemental lighting. Parallel to the operator lighting, the Lumi base+ and Relay switch on with the "Start" impulse. The lighting time set at the factory is 180 seconds. If the light function is activated via the CH 2 radio channel, the operator lighting, the Lumi base+ and the Relay can also be switched on and off separately. This does not trigger a travel command. After 60 minutes, the operator lighting, the Lumi base+ or the Relay are switched off automatically.

The Lumi base+ and the Relay accessories can be purchased from your specialist dealer or at:

[www.sommer.eu](http://www.sommer.eu)

## 10.15 Setting partial opening

This function allows you to set a desired partial opening. The door then does not open completely, but only to the set door position.

### Example:

A side-opening sectional door can be opened to allow a person to pass through. The partial opening function can only be used via radio control system or button 2, see Chapter "11.4 Button 2 for partial opening".



## INFORMATION

The lighting function or partial opening can be operated.



## INFORMATION

The specified partial opening can be approached from any position of the door.

# 10. Connections and special functions of the motor carriage

1. Close the door completely up to the door CLOSE end position.
2. Press the Radio button repeatedly to select radio channel CH 2 and to program the partial opening function to the desired transmitter button.
3. Set DIP switch 2 on the motor carriage to ON.
4. Press the desired button on the transmitter for the partial opening function.  
⇒ The door moves in door OPEN direction.
5. When the door reaches the desired partial opening position, press the button on the transmitter again.  
⇒ The door stops at the desired position.

## 10.16 Deleting partial opening

1. Set DIP switch 2 on the motor carriage to OFF.
2. Open the door completely up to the door OPEN end position.  
⇒ Partial opening is deleted.

To program a new position, see Chapter "10.16 Setting partial opening".

## 10.17 Wicket door safety device

The wicket door safety device prevents operation of the door with open wicket doors.

1. The wicket door safety device must be installed so that the switch reliably detects the open door. Do not install the wicket door safety device on the hinge side.
2. Connect the wicket door safety device on the terminal block on the motor carriage. The contact command is at 12 V/10 mA. The normally closed contact is potential-free.
3. Check the function.



### INFORMATION

If the wicket door is opened, the operator lighting on the motor carriage switches on. If the door closes, the operator lighting lights up for the set lighting time and then switches off. The lighting time can be modified with SOMlink and a WiFi-enabled device.



### INFORMATION

If the wicket door remains open longer than 60 minutes, the operator lighting switches off automatically after 60 minutes. This value can be changed via SOMlink and a WiFi-enabled device.



### INFORMATION

If the control unit receives a new command with the wicket door open, the LEDs of the operator lighting change from permanent to flashing light.

## 10.18 SOMlink

SOMlink makes it possible for **qualified specialists** to change functions and settings on the door operator. These include force and speed values as well as operating parameters and other convenient functions. You can access a demo version under:

[http://www.sommer-projects.de/gta\\_app/#home](http://www.sommer-projects.de/gta_app/#home)

If you would like to make changes, contact your specialist dealer.



### INFORMATION

SOMlink is a combination of an additional device and a web-based application for changing door operator functions. Since safety-relevant values can also be changed, SOMlink is only sold to qualified specialists. All changes to settings via SOMlink are logged.



### INFORMATION

All operator parameters are reset to the factory settings by a factory reset. All settings via SOMlink and WiFi-enabled device are also reset. The DIP switches can only be manually reset.



# 11. Connections and special functions of the ceiling control unit

## 11.1 Ceiling control unit circuit board

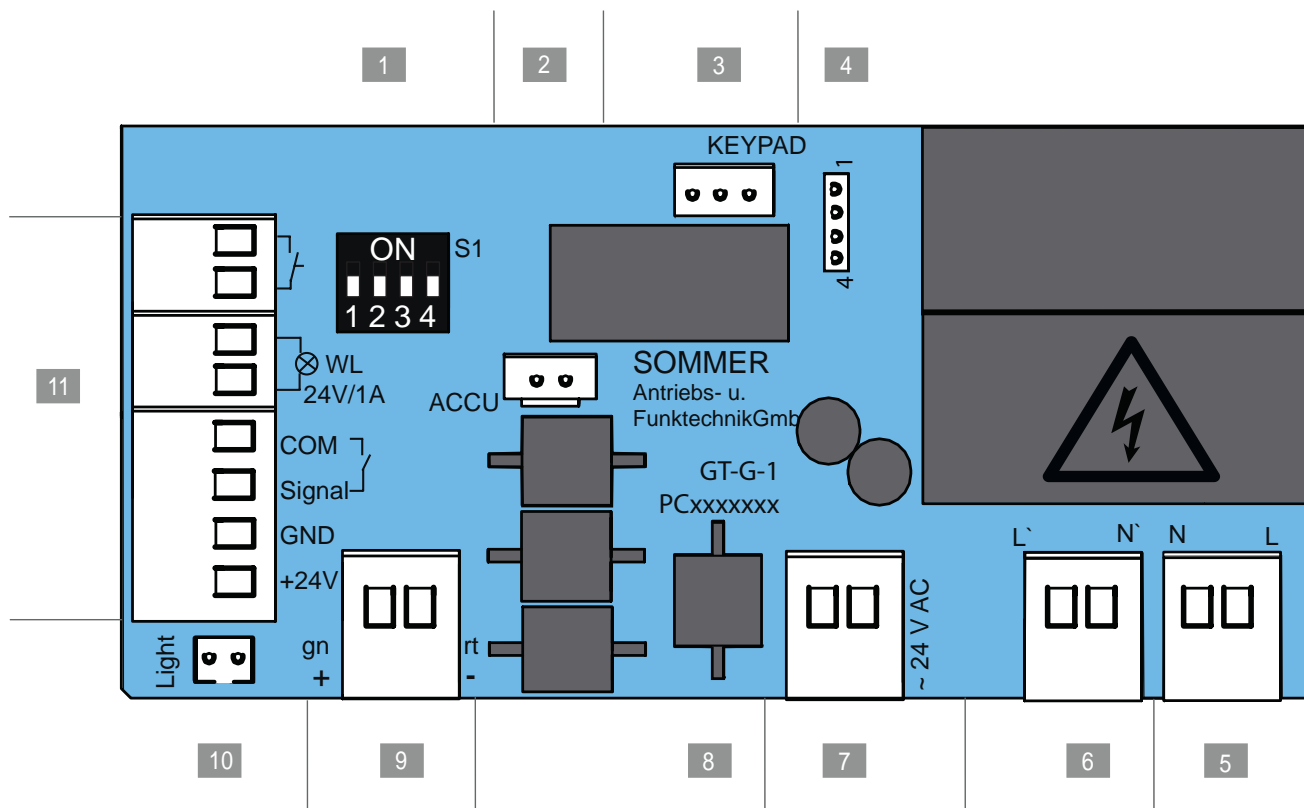

Fig. Ceiling control unit circuit board (complete version\*)

### Connection options to the ceiling control unit

1. DIP switches	7. 2-pin terminal block 24 V/AC transformer secondary side
2. ACCU slot Terminal for accumulator	8. Circuit board label
3. Slot, KEYPAD*, black Conex connection	9. 2-pin terminal block Chain and track, 24 V DC
4. Slot Terminal for Relay	10. Light slot, white Connection for Lumi base+ supplemental lighting
5. 2-pin terminal block Supply voltage 220 - 240 V AC, 50/60 Hz	11. 8-pin terminal block <ul style="list-style-type: none"> <li>• Button, potential-free</li> <li>• Warning light (24 V DC, max. 25 W)</li> <li>• 2/4-wire photocell (max. 100 mA regulated)</li> </ul>
6. 2-pin terminal block Primary side transformer 220 - 240 V AC, 50/60 Hz	

\*The version can vary depending on the type. This means the use of accessories can vary.

A connection diagram can be found in Chapter "19. Connection diagrams and functions of the DIP switches for A 550 L and A 800 XL".

# 11. Connections and special functions of the ceiling control unit

## 11.2 Connection options to the ceiling control unit

Observe in particular the following safety instructions for this chapter.



### **WARNING**

**Danger of crushing and shearing!**  
The door can be actuated by a button. Persons who cannot see the door and are in the range of movement of the mechanism or the safety edges may be injured by crushing or shearing.

- ▶ Keypads and other command devices may only be installed within view of the door.
- ▶ Only use keypads or other command devices when you can see the movement of the door.
- ▶ All danger zones must be visible during the entire door operation.
- ▶ Always keep the moving door in sight.
- ▶ Keep persons and animals clear of the range of movement of the door.
- ▶ Never stand under the opened door.



### **WARNING**

**Danger due to hot surfaces!**  
After frequent operation, parts of the motor carriage or the control unit may become hot. If the control unit cover is removed and hot parts are touched, they may cause burns.

- ▶ Allow the operator to cool down before removing the cover.



### **NOTE**

Never lay the control cable along a power line as this could cause interference in the control unit. Note the length of the control cable and install it correctly.



### **INFORMATION**

The control unit detects a short-circuit between chain and track and then switches the operator off. If the short circuit is no longer present, the operator runs normally again.



### **INFORMATION**

Control or regulating units in a fixed position must be mounted within sight of the door and at a height of at least 1.60 m.



### **INFORMATION**





The power cable is approx. 1.2 m long.

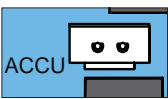
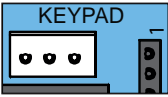

### **INFORMATION**

The maximum cable length for connected accessories is 25 m.

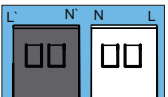
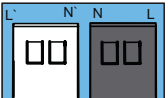
# 11. Connections and special functions of the ceiling control unit

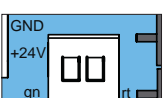
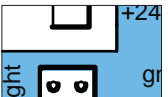
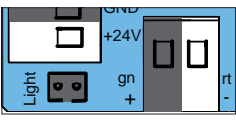
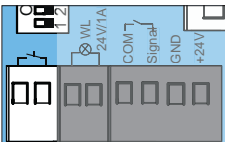
Circuit board section	Function/ application example
	ACCU slot Terminal for accumulator
	Slot, KEYPAD, black Connection for Conex
	Relay slot Switching capacity max. 250 V AC, 5 A or max. 24 V DC, 5 A
	2-pin terminal block Supply voltage 220 - 240 V AC, 50/60 Hz
	2-pin terminal block Primary side transformer 220 - 240 V AC, 50/60 Hz
	2-pin terminal block Secondary side transformer 24 V AC
	2-pin terminal block Chain and track +24 V DC
	Light slot*, white Supplemental lighting Lumi base+
	External accessories +24 V DC (terminal block photocell) GND = rd (terminal block chain/track) max. 100 mA (max. 500 mA if an LED warning light with a max. of 3 W or no warning light is connected)
	2-pin terminal block Button Potential-free

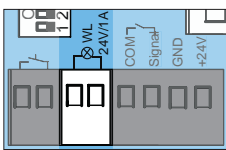
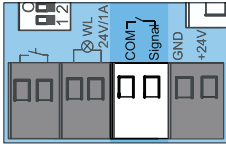
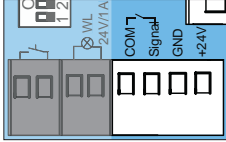
Circuit board section	Function/ application example
	2-pin terminal block Warning light +24 V DC, max. 25 W
	4-pin terminal block Two-wire photocell Any polarity or Button 2, partial opening
	4-wire photocell +24 V DC, 100 mA (regulated)

The version can vary depending on the type. This means the use of accessories can vary.

For more information on the accessories, contact your specialist dealer or see:

[www.sommer.eu](http://www.sommer.eu)



## INFORMATION

If a photocell is used, it must not be actuated when starting the programming. If a photocell is used as a frame photocell, move the door to the centre position.



# 11. Connections and special functions of the ceiling control unit





## 11.3 Setting the DIP switches on the ceiling control unit

Special functions can be set with the DIP switches on the ceiling control unit.

All DIP switches are set to OFF by default.

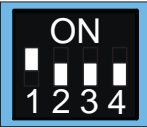
➔ **NOTE**

Do not use a metal object to set the DIP switches, because this may damage the DIP switches or the circuit board. Use a suitable tool to set the DIP switches, such as a flat, thin plastic object.

Setting the DIP switches of the ceiling control unit	ON	OFF 
<b>1</b> 	<ul style="list-style-type: none"> <li>"Conex" additional circuit board</li> <li>T1 defines door OPEN</li> <li>T2 defines door CLOSE</li> </ul>	<ul style="list-style-type: none"> <li>"Conex" additional circuit board</li> <li>T1 pulse sequence</li> <li>T2 lighting function/partial opening</li> </ul>
<b>2</b> 	<ul style="list-style-type: none"> <li>Relay is activated during door movement and if the door is not closed*</li> </ul>	<ul style="list-style-type: none"> <li>Lighting function</li> </ul>
<b>3</b> 	<ul style="list-style-type: none"> <li>Continuous power to the complete system activated</li> </ul>	<ul style="list-style-type: none"> <li>Power-saving mode activated</li> </ul>
<b>4</b> 	<ul style="list-style-type: none"> <li>COM and Signal activated as button input (partial opening)</li> </ul>	<ul style="list-style-type: none"> <li>COM and Signal activated as safety contact for photocell</li> </ul>

\* e.g. Door status display

## 11.4 Button 2 for partial opening

If required, another button can be connected for partial opening operation. After installation of the keypad, all settings must be made on the ceiling control unit and the motor carriage.

➔ **NOTE**

The control unit cover is connected to the circuit board of the ceiling control unit via a connection cable. If an accumulator has been installed, it is also connected to the circuit board. Carefully remove the control unit cover and disconnect the connections to prevent damage to the ceiling control unit.



### INFORMATION

If button 2 (partial opening) is used, a photocell cannot be connected. The automatic closing operating mode is then not possible.

### Installing the keypad

- When installing the potential-free keypad, select a suitable position at a height of at least 1.6 m.
- Install the keypad.
- The keyboard cable for the ceiling control unit must be firmly secured to prevent displacement.

### Installation of the control cable and settings on the ceiling control unit

- Disconnect the operator from the mains voltage. Check it is disconnected from the power supply.
- Unscrew and remove the cover from the ceiling control unit, see Chapter "7.2 Cover of the ceiling control unit".
- If an accumulator is used, it must also be disconnected, see Chapter "11.11 Installing and removing the accumulator":
- Remove the control unit cover.

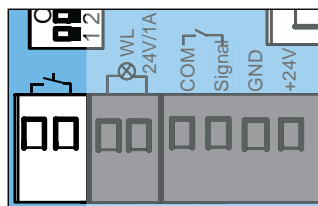

Fig. 5

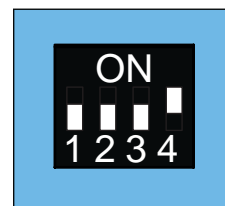

Fig. 6

# 11. Connections and special functions of the ceiling control unit

5. Connect the cable of button 2 to the terminal block for COM and Signal.  
⇒ Button 2 is connected.
6. Set DIP switch 4 on the wall unit to ON.
7. Plug in the connection cable for the button and for the accumulator, if necessary.
8. Close the ceiling control unit in reverse order, see Chapter "11.11 Installing and removing the accumulator" and "7.2 Cover of the ceiling control unit".
9. Connect the operator to the mains voltage.  
Check that the power supply is connected.

## Settings on the motor carriage

To determine the partial opening door position, the following settings must be made on the motor carriage.

1. Close the door completely up to the door CLOSE end position.
2. Open the motor carriage, see Chapter "7.1 Cover of the motor carriage".
3. Set DIP switch 2 on the motor carriage to ON.
4. Press button 2 for the partial opening function.  
⇒ The door moves in door OPEN direction.
5. Press button 2 again for the desired position for stopping.  
⇒ The door stops at the desired position.

## 11.5 Deleting partial opening

1. Set DIP switch 2 on the motor carriage to "OFF."
2. Open the door completely up to the door OPEN end position.  
⇒ Partial opening is deleted.

To program a new position, see Chapter "10.15 Setting partial opening".

## 11.6 Photocell and frame photocell

A 2-wire photocell from **SOMMER** or a 4-wire photocell can be connected to the control unit. The control unit automatically detects which version it is and sets itself to that version.

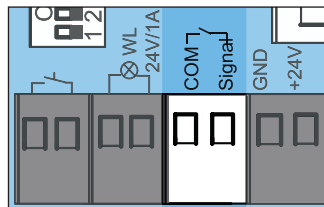

Fig. Terminal block for a 2-wire photocell

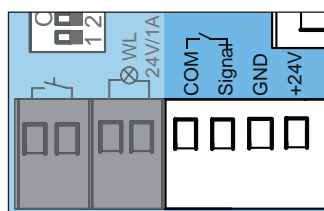

Fig. Terminal block for a 4-wire photocell



### INFORMATION

If a photocell is retrofitted on a programmed system, the control unit must be reset, see Chapter "12.10 Reset".



### INFORMATION

If a photocell is used, it must not be triggered when starting the programming. If a photocell is used as a frame photocell on the door, move the door to the centre position.



### INFORMATION

During commissioning, the frame photocell must not be interrupted by persons or objects.

### Frame photocell

1. Install the frame photocell in the frame, see separate instructions for "Frame photocell".
2. Align the frame photocell and connect to the ceiling control unit.
3. Initial operation is performed as described in Chapter "9. Initial operation".

# 11. Connections and special functions of the ceiling control unit

- ⇒ When the door passes the frame photocell, the illumination power of the operator lighting is reduced.  
If the illumination power is not reduced, the frame photocell must be realigned and the control unit must be reset.
- ⇒ During initial operation, the operator learns the exact position of the frame photocell in order to blank it out in normal mode shortly before reaching the door.

4. Check the frame photocell function.

## 11.7 Wallstation

Other functions are available with the Wallstation. For example, a travel command can be executed, the lighting can be switched on or off or the operator can be locked. The selection of the locked areas can be changed via SOMlink. The connection features a polarity-protected 2-wire bus. The Wallstation is expected to be available starting in 07.2017.

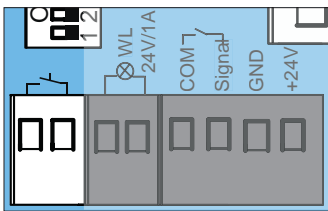

Fig. Button connection



### INFORMATION

The connection features a polarity-protected 2-wire bus.

### Installing the Wallstation

See the separate instructions for the "Wallstation" for installation.

1. The following conditions must be met for installation of the Wallstation:
  - a second separate access point
  - a suitable position at a minimum height of 1.6 m
2. Install the Wallstation.
3. The Wallstation cable for the ceiling control unit must be firmly secured to prevent displacement.
4. Connect the Wallstation to the button terminal.
5. The power-saving mode must be deactivated. Set DIP switch 3 on the ceiling control unit to ON.

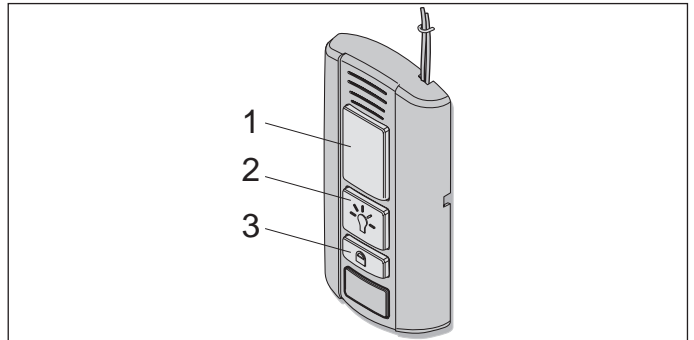

Fig. Wallstation

### Functions of the buttons

- Opening, stopping and closing the door
- Turning the lighting on and off
- Locking or unlocking the operator

### Opening, closing and stopping the door

1. Press the button (1) to open and close.  
⇒ The door opens or closes depending on the starting position.
2. Press the button (1) during the opening or closing process.  
⇒ The door stops.
3. Press the button (1) again.  
⇒ The door moves into the respective starting position.

### Turning the lighting on and off

The button (2) lights up green when the Wallstation is ready for operation and the operator is not locked.

1. Press the button (2).  
⇒ Operator lighting switched on.
2. Pressing the button (2) again switches the operator lighting back off.  
⇒ Operator lighting off.



### INFORMATION

If the operator lighting is not switched off manually, it switches off automatically after 60 minutes. This value can be changed via SOMlink and a WiFi-enabled device.



The lighting cannot be switched off when the operator is moving.

# 11. Connections and special functions of the ceiling control unit

## Locking or unlocking the operator

Unwanted access can be prevented by locking the operator, for example in the absence of the user or to prevent unintentional activation with a handheld transmitter.

The following functions are deactivated in the factory settings when the lock button is activated:

- Radio (handheld transmitter)
- Senso ventilation function
- Command device (corded external button)

### To lock:

The button (2) on the Wallstation lights up green when the operator is unlocked. The button (2) lights up red when the operator has been locked by the Wallstation.

1. Press and hold the button (3) for at least 5 seconds with the door closed.
  - ⇒ Button (2) flashes green.
  - ⇒ After 5 seconds, button (2) lights up red.
  - ⇒ Locking function activated.
  - ⇒ All the functions of the operator are locked.



### INFORMATION

If the door was still open, it can be closed using the handheld transmitter. Only then are all operator functions locked.

### To unlock:

1. Press the button (3) for at least 5 seconds.
  - ⇒ Button (2) flashes red.
  - ⇒ Button (2) lights up green.
  - ⇒ Locking function deactivated.
  - ⇒ All the functions of the operator are activated again.



### INFORMATION

All locking and unlocking functions can be modified and adjusted with SOMlink and a WiFi-enabled device. For more information, ask your specialist dealer.



## 11.8 Conex

Two corded external buttons can be connected to the KEYPAD connection with the Conex accessory part. The function of the external buttons can be configured via DIP switch 1 of the ceiling control unit. The factory setting of DIP switch 1 is "OFF."

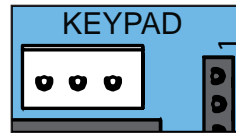



Fig. Keypad connection

The Conex accessory part is plugged into the KEYPAD slot, see separate "Conex" instructions.

Setting the DIP switches of the ceiling control unit	ON	OFF 
1 	<ul style="list-style-type: none"> <li>• "Conex" additional circuit board</li> <li>• T1 defines door OPEN</li> <li>• T2 defines door CLOSE</li> </ul>	<ul style="list-style-type: none"> <li>• "Conex" additional circuit board</li> <li>• T1 pulse sequence</li> <li>• T2 lighting function/partial opening</li> </ul>

## 11.9 Output OC

A door status display can be shown with the Output OC (open collector output) accessory part. To do this, set DIP switch 2 on the ceiling control unit to "ON."

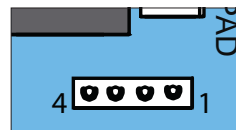

Fig. Relay slot for Output OC

The Output OC accessory part is plugged into the Relay slot, see separate instructions for "Output OC".

## 11.10 Relay

External lighting such as the garage light, courtyard light or door status display can be controlled with the Relay accessory part. The function depends on the setting of DIP switch 2. See also Chapter "11.3 Setting the DIP switches on the ceiling control unit"

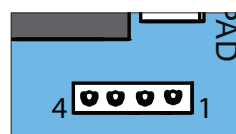

Fig. Relay slot

# 11. Connections and special functions of the ceiling control unit

The Relay is plugged into the Relay slot on the ceiling control unit, see separate instructions for "Relay". The max. switching capacity is 250 V AC, 5 V or 24 V DC, 5 A.

## 11.11 Installing and removing the accumulator

The accumulator can bridge approximately 5 cycles within 12 hours in the event of a power failure. Only a **qualified electrician** is permitted to install, test and replace the accumulator. See also chapter "7.1 Cover of the motor carriage". Observe the information in the separate instructions for the accumulator.

### NOTE

If an accumulator has been installed, it is connected to the circuit board. Carefully remove the control unit cover and disconnect the connections to prevent damage to the ceiling control unit.



### INFORMATION

Only an original accumulator from SOMMER may be used.



### INFORMATION

Initial operation is not supported if the accumulator is the sole power supply. Mains voltage is required for initial operation of the operator.



### INFORMATION

The accumulator can only be recharged for a limited number of cycles. This depends on the use and settings.

## Installing the accumulator

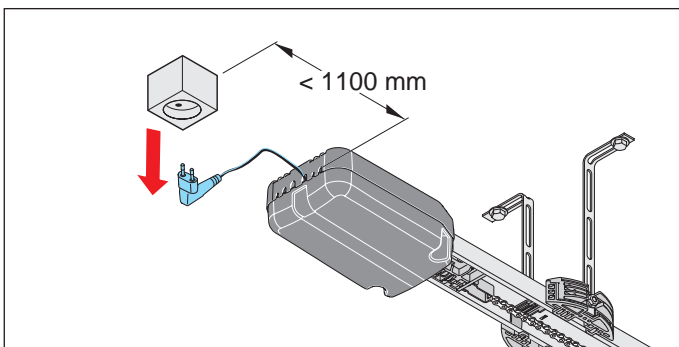

Fig. 1

1. Disconnect the operator from the mains voltage. Check it is disconnected from the power supply.

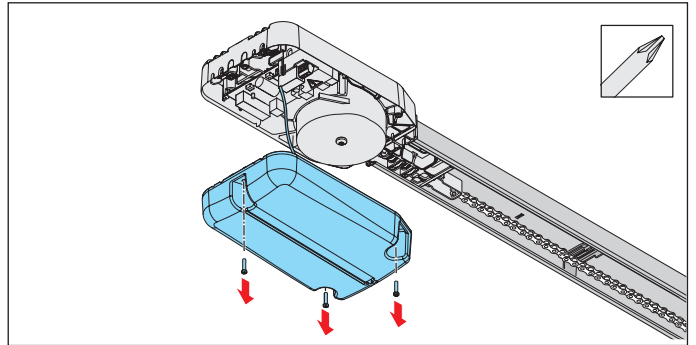

Fig. 2

2. Unscrew and remove the cover from the ceiling control unit.

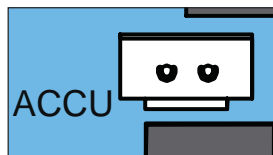

Fig. 3

3. Place the accumulator loosely in its position in the cover and plug the accumulator plug into the circuit board in the ACCU slot.

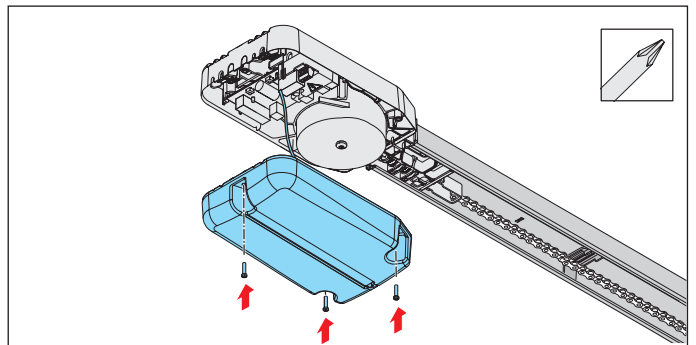

Fig. 4

4. Screw on cover.
5. Attach the sticker "ACCU INSIDE" sticker to the outside of the housing in a highly visible place.
6. Run a function test.
  - ⇒ Pull the power plug out of the power outlet.
  - ⇒ The operator is powered by the accumulator.
7. Press the button on the handheld transmitter.
  - ⇒ Operator opens or closes the door at reduced speed.
8. Connect the operator to the mains voltage. Check that the power supply is connected.

# 11. Connections and special functions of the ceiling control unit

## Removing the accumulator

The accumulator is removed in the reverse order, see Chapter "11.11 Installing and removing the accumulator", section "Installing the accumulator".



### **DANGER**

**Danger of hazardous substances!** Improper storage, use or disposal of accumulators, batteries and operator components are dangerous for the health of humans and animals. Serious injury or death may result.

- ▶ Accumulators and batteries must be stored out of the reach of children and animals.
- ▶ Keep accumulators and batteries away from chemical, mechanical and thermal influences.
- ▶ Do not recharge old accumulators and batteries.
- ▶ Components of the operator as well as old accumulators and batteries must not be disposed of with household waste. They must be disposed of properly.



### **NOTE**

Dispose of all components in accordance with local or national regulations to avoid environmental damage.



### **INFORMATION**

All operator components that have been taken out of service must not be disposed of with household waste, as they contain hazardous substances. The components must be disposed of correctly at an authorised recycling centre. The local and national regulations must be observed.



### **INFORMATION**

Old accumulators and batteries must not be disposed of with household waste, as they contain hazardous substances. These must be disposed of properly at municipal collection points or in containers provided by dealers. National guidelines must be observed.



# 12. twin operation

## 12.1 twin operation

Two operators can be controlled with one control unit, for example in a double garage with two garage doors. Both operators are connected to one control unit for this purpose.

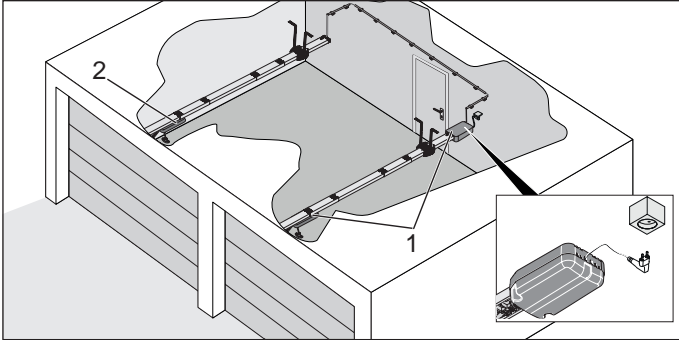

Fig. Installation example for twin operation, slave (1) and master (2)

### Mode of operation

If one of the operators receives a command and starts to move, the other operator is locked for this time. The other operator can only be started after the movement has stopped.



### INFORMATION

Both operators cannot be operated at the same time.

## 12.2 Installing the operators

The installation of the operators is described here using an example.



### INFORMATION

Master and slave are assigned regardless of the installation.

1. Install the operators on the two doors as described in Chapter "6. Installation".
  - Insert the control unit into one track.
  - Insert the plug-in unit with the connection cable into the other track.

## 12.3 Selecting and configuring master and slave

### Requirements

Both operators are configured as a master in the factory settings. The main communication with the control unit is effected via the master.



### INFORMATION

No automatic closing function and no energy-saving mode are possible in twin operation.

1. Set DIP switches 1 and 3 on the ceiling control unit to "ON."
2. Connect the ceiling control unit to the mains voltage. Check that the power supply is connected.
3. Configure the operator with the ceiling control unit (1) as the slave. To do this, establish a connection to the motor carriage via SOMlink and a WiFi-enabled device.
4. In the menu, under the "twin operation" settings, configure "Operator is slave" for the selected operator and save the entry. Check the entry.
5. Disconnect the ceiling control unit from the mains supply for 15 seconds.

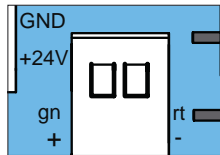

Fig. Connection of chain and track for both operators to the control unit

Terminal block	Function
gn +	Track
rd -	Chain

6. Connect the operator without the ceiling control unit, the master (2), to the ceiling control unit parallel to the terminal block for chain (rd) and track (gn). The connection cable must be firmly secured to prevent displacement.
7. Reconnect the control unit to the mains voltage.
8. Put both operators into operation successively, see Chapter "9. Initial operation", "10. Connections and special functions of the motor carriage" and "11. Connections and special functions of the ceiling control unit".

## 12. twin operation

- Programme the handheld transmitters for the respective operators, see Chapter "10.4 Explanation of the radio channels" and "10.5 Programming the transmitter".



### INFORMATION

Only one handheld transmitter button can be assigned per function. Undesired malfunctions could otherwise occur.

### 12.4 Partial opening

One partial opening can be programmed for each of the two operators (master and slave). Programming or deletion is performed as for the standard equipment, see Chapter "10.15 Setting partial opening" and "10.16 Deleting partial opening".

#### Example:

Master on radio channel CH 2 (partial opening) on handheld transmitter button 3. For the slave, on radio channel CH 3 (partial opening) on handheld transmitter button 4.

#### Corded

The COM input and signal on the ceiling control unit can be used for this purpose. DIP switch 4 on the ceiling control unit must be ON.

The input is then no longer available for connection of a photocell.

#### Mode of operation

If button 2 (partial opening) is activated, the master receives the partial opening command. See also Chapter "10.16 Setting partial opening".

### 12.5 Defined opening and closing

The functions defined opening and closing of the operators (master and slave) can only be configured via the CH 3 and CH 4 radio channels. These settings are not available when corded or via the Conex accessory part.

### 12.6 Door status display

During door movement and if the door is not closed, the Relay (MUFU) trips. DIP switch 2 must be "ON." The Relay remains activated until both operators (master and slave) are again at the door CLOSE end position.

### 12.7 Lighting for twin operation

The lighting can be switched on and off for the selected operator via the respective handheld transmitter. This also applies for the connected supplemental lighting. See also Chapter "10.15 Adjusting the lighting function".

### 12.8 Photocell

Optionally, a photocell can be connected. The photocell must be configured in such a way that it can be aligned to cover two doors. If the photocell is interrupted, the operator of the moving door reverses. See also Chapter "11.6 Photocell and frame photocell".



### INFORMATION

If a photocell is retrofitted on a programmed system, the control system must be reset, see Chapter "10.12 Resetting the control unit".

### 12.9 External button

With the Conex additional circuit board, both operators (master and slave) can be operated in pulse sequence mode. Fit the Conex as described in the separate instructions. Set DIP switch 1 on the ceiling control unit to ON.

#### Mode of operation

Button 1 - master

Button 2 - slave

### 12.10 Reset

The slave becomes the master again when a factory reset is carried out. The operator must be reconfigured for the slave via SOMlink and a WiFi-enabled device, see Chapter "12.3 Selecting and configuring master and slave".



# 13. Function test and final test

## 13.1 Testing obstacle detection

Observe in particular the following safety instructions for this chapter.

After initial operation of the operator, the force measurement of the operator must be checked with a force measurement device and an obstacle detection test must be performed.



### WARNING

**Danger due to projecting parts!**  
Parts must not project into public roads or footpaths. This also applies while the door is moving. Persons and animals may be seriously injured.

- ▶ Keep public roads and footpaths clear of projecting parts.



### WARNING

**Danger of entrapment!**  
If the force setting is too high, persons or animals in the movement area of the door may be trapped and pulled along with the door. Severe injuries or death may result.

- ▶ The force setting is relevant to safety and must be carried out by a trained specialist.
- ▶ You must proceed with extreme caution if you check and if necessary adjust the force setting.



### WARNING

**Danger of crushing and shearing!**  
If the door moves and there are persons or animals in the movement area, crushing and shearing injuries may be caused by the mechanism and safety edges of the door.

- ▶ Note that obstacle detection does not operate below 50 mm.
- ▶ The obstacle detection must be tested once a month.
- ▶ Only use the operator when you have a direct view of the door.
- ▶ All danger zones must be visible during the entire door operation.
- ▶ Always keep the moving door in sight.
- ▶ Keep persons and animals clear of the range of movement of the door.
- ▶ Never put your hand near the door when it is moving or near moving parts. In particular, do not reach into the moving push arm.
- ▶ Do not reach into the ceiling suspension unit when the motor carriage is running along the track.
- ▶ Do not drive through the door until it has opened completely.
- ▶ Never stand under the opened door.



### NOTE

Observe the national standards, guidelines and regulations for cut-off of the operating forces.



### NOTE

The obstacle detection must be tested once a month to prevent damage to the operator.



### INFORMATION

After installation of the operator, the person responsible for the installation must complete an EC Declaration of Conformity for the door system in accordance with Machinery Directive 2006/42/EC and apply the CE mark and a type plate. This documentation and this Installation and Operating Manual for the operator must be handed over to the user. This also applies if the operator is retrofitted to a manually operated door.

# 13. Function test and final test



## INFORMATION

**Reversing:** The operator stops on contact with an obstacle and then moves a short distance in the opposite direction to release the obstacle. In the automatic closing function, the door opens completely if an obstacle is detected.



## INFORMATION

The operating forces can be modified and adjusted with SOMlink and a WiFi-enabled device. For more information, ask your specialist dealer.



After successful testing of the force settings, the obstacle detection and the functions, the qualified specialist must issue the EC Declaration of Conformity and attach the CE mark and type plate to the door system.

The operator must reverse in the door OPEN direction when it is loaded with a weight of 20 kg. The weight is fastened in the centre of the bottom edge of the door for this purpose.

The door must reverse during the door CLOSE movement if it hits a 50-mm-high obstacle on the ground.

1. Open the door with the operator.
2. Place a 50-mm-high object in the centre of the door.

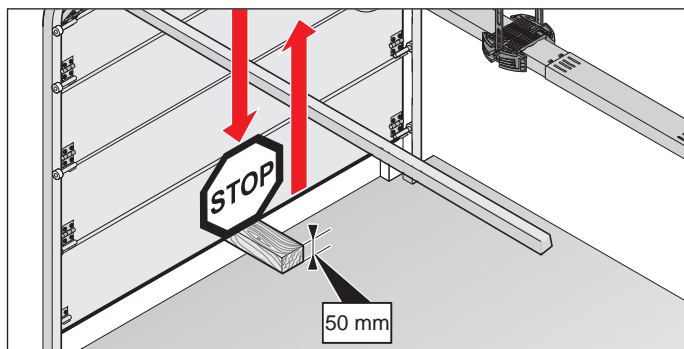

Fig. Example: Obstacle detection on sectional door

3. Close the door with the operator.
  - ⇒ If the door hits an obstacle, the operator must immediately reverse.
  - ⇒ The operator opens the door completely at a pulse from the transmitter.
  - ⇒ If the operator does not reverse, a position reset is required, see Chapter "12.10 Reset". The positions and the forces must be reprogrammed.

## 13.2 Handover of door system

The qualified specialist must instruct the user:

- on the operation of the operator and its dangers
- on the handling of the manual emergency release
- on the regular maintenance, testing and care measures which the user can carry out, see Chapter "15. Maintenance and care"
- on the troubleshooting measures which the user can carry out, see Chapter "16. Troubleshooting"

The user must be informed about which work may only be performed by a qualified specialist:

- installation of accessories
- settings
- Regular maintenance, testing and care, except that described in Chapter "15. Maintenance and care"
- troubleshooting, except that described in Chapter "16. Troubleshooting".
- repairs

The following documents for the door system must be handed over to the user:

- the installation and operating manuals for the operator and the door
- inspection book
- EC Declaration of Conformity
- handover protocol for the operator



<http://som4.me/konform>

## 13. Function test and final test

---

The user is responsible for:

- the intended use of the operator
- its good condition
- operation
- instructing all users how to use the door system and in the associated hazards
- on the handling of the manual emergency release
- maintenance, testing and care
- tests by a qualified specialist
- troubleshooting in case of faults by a qualified specialist

The user must keep this Installation and Operating Manual ready for consultation in the vicinity of the door system at all times.

# 14. Operation

## 14.1 Safety information on operation

In particular, observe the safety instructions below and the safety instructions in Chapters "15. Maintenance and care" and "16. Troubleshooting".

The operator must not be used by persons with restricted physical, sensory or mental capacity or who lack experience and knowledge. All users must be specially instructed and have read and understood the installation and operating instructions.

Children must never play with or use the operator, even under supervision. Children must be kept clear of the operator. Handheld transmitters or other command devices must never be given to children. Handheld transmitters must be stored in a safe place and protected against unintended and unauthorised use.



### **DANGER**

**Danger if not observed!**  
If safety instructions are not observed, serious injury or death may result.

- ▶ All safety instructions must be complied with.



### **DANGER**

**Danger due to use of the operator with incorrect settings or when it is in need of repair!**  
If the operator is used despite incorrect settings or if it is in need of repair, severe injury or death may result.

- ▶ The operator may only be used with the required settings and in the proper condition.
- ▶ You must have faults repaired professionally without delay.



### **WARNING**

**Danger due to falling parts of doors!**

Actuating the emergency release can lead to uncontrolled door movement if

- springs are weakened or broken.
- the door has not been optimally weight-balanced.

**Falling parts may cause a hazard. Severe injuries or death may result.**

- ▶ Check the weight balance of the door at regular intervals.
- ▶ Pay attention to the movement of the door when the emergency release is actuated.
- ▶ Keep clear of the movement area of the door.
- ▶ Keep persons and animals clear of the range of movement of the door.



### **WARNING**

**Danger of entrapment!**

Persons or animals in the movement area of the door may be trapped and pulled along with the door. Severe injuries or death may result.

- ▶ Keep clear of the moving door.

# 14. Operation



## **WARNING**

**Danger of crushing and shearing!**  
If the door moves and there are persons or animals in the movement area, crushing and shearing injuries may be caused by the mechanism and safety edges of the door.

- ▶ Only use the operator when you have a direct view of the door.
- ▶ All danger zones must be visible during the entire door operation.
- ▶ Always keep the moving door in sight.
- ▶ Keep persons and animals clear of the range of movement of the door.
- ▶ Never put your hand near the door when it is moving or near moving parts. In particular, do not reach into the moving push arm.
- ▶ Do not reach into the ceiling suspension unit when the motor carriage is running along the track.
- ▶ Do not drive through the door until it has opened completely.
- ▶ Never stand under the opened door.



## **WARNING**

**Danger due to optical radiation!**  
Looking into an LED at short range for an extended period may cause optical glare. This may temporarily reduce vision. This may cause serious or fatal accidents.

- ▶ Never look directly into an LED.



## **NOTE**

**If the weight compensation of the door is incorrectly adjusted, the operator may be damaged.**

- The door must be stable.
- It must not bend, rotate or twist when opening and closing.
- The door must move easily in its tracks.

**Defects must be repaired without delay by a qualified specialist.**



## **NOTE**

**Objects in the movement area of the door may be jammed and damaged. Objects must not be in the range of movement of the door.**



## **INFORMATION**

**Keep this Installation and Operating Manual accessible at all times at the place of use.**

## 14.2 Handover to the user

The user must ensure that the CE mark and the type plate have been attached to the door system. The following documents for the door system must be handed over to the user:

- the Installation and Operating Manuals for the operator and the door
- inspection book
- EC Declaration of Conformity
- handover protocol
- The qualified specialist must instruct the user:
  - on the operation of the operator and its dangers
  - on the handling of the manual emergency release
  - on regular maintenance, testing and care which the user can carry out

The user must be informed about which work may only be performed by a qualified specialist:

- installation of accessories
- settings
- regular maintenance, testing and care which can be carried out by the user, except that described in Chapter "15. Maintenance and care"
- troubleshooting which can be carried out by the user, except that described in Chapter "16. Troubleshooting"

The user is responsible for:

- the intended use of the operator
- its good condition
- operation
- instructing all users how to use the door system and in the associated hazards
- on the handling of the manual emergency release
- maintenance, testing and care
- tests by a qualified specialist
- troubleshooting in case of faults by a qualified specialist

# 14. Operation

The user must keep this Installation and Operating Manual ready for consultation in the vicinity of the door system at all times.

## 14.3 Operating modes of door movement



### WARNING

**Danger of crushing and shearing!**  
The door can be actuated by a keypad or another command device.

Persons who cannot see the door and are in the range of movement of the mechanism or the safety edges may be injured by crushing or shearing.

- ▶ Keypads or other command devices may be used only if the movement of the door can be viewed directly.
- ▶ Keep persons and animals clear of the range of movement of the door.
- ▶ Never stand under the opened door.



### INFORMATION

All functions can be programmed for all buttons.

#### Radio channel CH 1

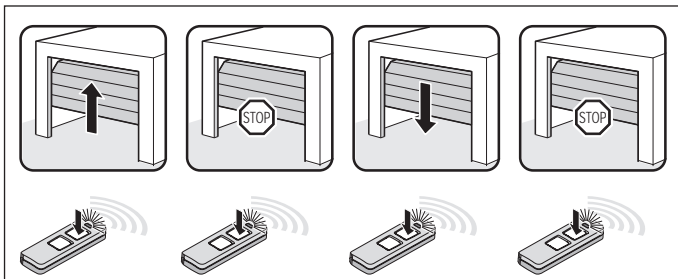

Fig. Pulse sequence door OPEN, door stop, door CLOSE, door stop

#### Radio channel CH 2

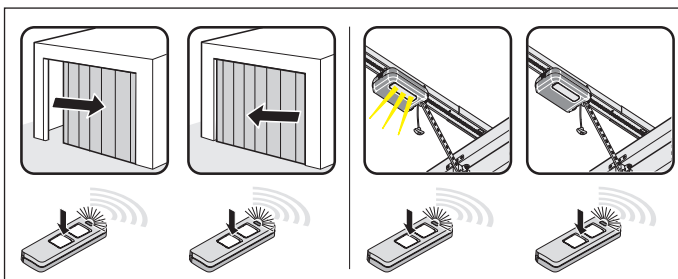

Fig. Pulse sequence for:  
Partial opening: DIP switch 2 "ON"  
Lighting function: DIP switch 2 "OFF"

#### Radio channel CH 3

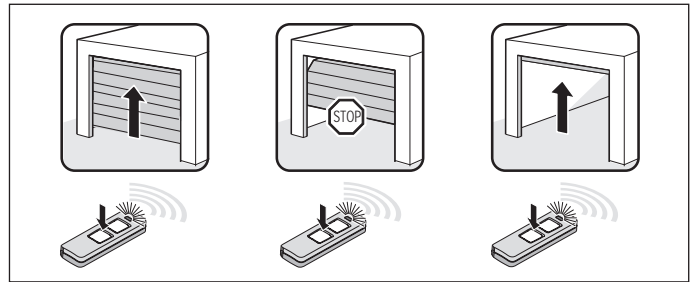

Fig. Pulse sequence for defined door OPEN

#### Radio channel CH 4

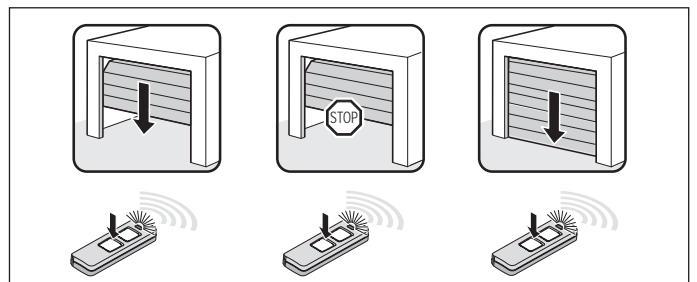

Fig. Pulse sequence for defined door CLOSE

# 14. Operation

## 14.4 Obstacle detection

The operator stops and reverses slightly if it encounters an obstacle. This prevents injury and damage to property. The door will be partially or completely opened, depending on the setting. The partial reversion is pre-set at the factory. Full reversion can be set via SOMlink and a WiFi-enabled device.



### INFORMATION

**Reversing: The operator stops when it hits an obstacle. The door then moves slightly in the opposite direction to release the obstacle. In the automatic closing function, the door opens completely.**

The following safety devices are installed to detect obstacles:

- photocell (object protection)
- safety contact strips (personal protection)
- obstacle detection of the operator (personal protection)

See also Chapter "15. Maintenance and care".

## 14.5 Power-saving mode

To save energy, the operator control unit switches to power-saving mode after the factory-specified period. Connected accessories are deactivated and then reactivated at the next command from a button or radio. Connected accessories may include: photocell, safety contact strip and external radio receiver. Because external radio receivers are deactivated in power-saving mode, they cannot receive commands from the remote control and send them to the operator. Set DIP switch 3 to the ON position to power the entire system continuously. Power-saving mode is deactivated.

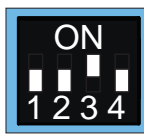
Setting the DIP switches of the ceiling control unit	ON	OFF 
3 	• Continuous power to the complete system activated	• Power-saving mode activated



### INFORMATION

**The factory-set period before the control unit switches to power-saving mode is 20 seconds. This value cannot be changed.**

## 14.6 Operation during power failure

The programmed force values and end positions of the operator remain saved in the event of a power failure. After the power supply has been restored, the first movement of the operator after a pulse is always door OPEN.

Also follow the instructions for emergency release in Chapter "11.11 Installing and removing the accumulator" and "14.7 Function of the emergency release".

## 14.7 Function of the emergency release

In the event of a power failure, the door can be opened and closed manually from the inside using a mechanical emergency release.

Observe in particular the following safety instructions for this chapter.



### WARNING

**Danger for trapped persons! Persons may be trapped inside the garage. If trapped persons cannot free themselves, severe injury or death may result.**

- ▶ Test the operation of the emergency release regularly from inside and if necessary, also from outside.
- ▶ You must have faults repaired professionally without delay.



### WARNING

**Danger due to falling parts of doors! If the emergency release is actuated, weak or broken springs may cause the door to close suddenly and unexpectedly. This may cause serious or fatal injury.**

- ▶ The emergency release should be used only with the door closed.
- ▶ Use the emergency release with great caution if the door is open.
- ▶ Keep persons and animals clear of the range of movement of the door.

# 14. Operation



## NOTE

The emergency release is only suitable for opening or closing the door in an emergency. The emergency release is not suitable for regular opening or closing. This could cause damage to the operator and door. The emergency release must only be used in emergencies such as a power failure.



## NOTE

During emergency release, the door could open or close by itself surprisingly quickly due to a broken spring or incorrect setting of the weight balancing. Damage to the door system could occur.



## NOTE

After the operator is locked back in, move the door to the door OPEN end position. Otherwise the limit stop will be hit with too much force.



## NOTE

Objects in the movement area of the door may be jammed and damaged. Objects must not be in the range of movement of the door.



## INFORMATION

It can be locked and released in any door position.

1. Disconnect the operator from the mains voltage. Check it is disconnected from the power supply.

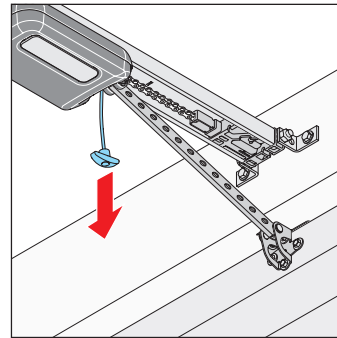

Fig. 2

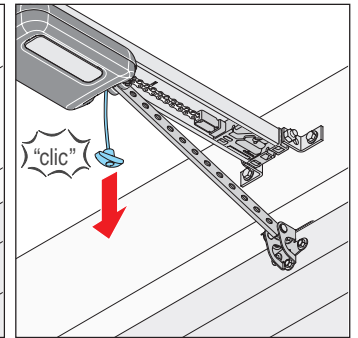

Fig. 3

2. Pull once on the emergency release cord.  
⇒ **The motor carriage is released.**  
⇒ Door can be moved by hand.
3. Pull the emergency release cord once more.  
⇒ **The motor carriage is locked.**  
⇒ The door can only be moved by the operator.
4. Connect the operator to the mains voltage. Check that the power supply is connected.
5. Give the operator a command.  
⇒ After a power failure, the first pulse of the operator is always in the door OPEN direction.  
⇒ The operator must drive completely to the door OPEN end position.



# 15. Maintenance and care

## 15.1 Safety instructions for maintenance and care

Follow the basic safety instructions listed below. Service the operator regularly as directed below. This ensures safe operation and a long service life for your operator.



### **DANGER**

**Danger if not observed!**  
If safety instructions are not observed, serious injury or death may result.

- ▶ All safety instructions must be complied with.



### **DANGER**

**Danger due to electric current!**  
Contact with live parts may result in electric current flowing through the body. Electric shock, burns or death may result.

- ▶ All work on electrical components must be carried out by a **trained electrician**.
- ▶ Disconnect the mains plug before working on the operator.
- ▶ If an accumulator is connected, disconnect it from the control unit.
- ▶ Check that the operator is not live.
- ▶ Secure the operator against being switched back on.



### **WARNING**

**Danger of falling!**  
Unsafe or defective ladders may tip and cause fatal or serious accidents.

- ▶ Use only a non-slip, stable ladder.
- ▶ Ensure that ladders are safely positioned.



### **WARNING**

**Danger for trapped persons!**  
Persons may be trapped inside the garage. If trapped persons cannot free themselves, severe injury or death may result.

- ▶ Test the operation of the emergency release regularly from inside and if necessary, also from outside.
- ▶ You must have faults repaired professionally without delay.



### **WARNING**

**Danger due to falling parts of doors!**  
Parts of the door may become detached and fall. If persons or animals are hit, this may cause serious injury or death.

- ▶ Always keep the moving door in sight.
- ▶ Keep all persons and animals away from the door until it is completely opened or closed.



### **WARNING**

**Danger of crushing and shearing!**  
If the door moves and there are persons or animals in the movement area, crushing and shearing injuries may be caused by the mechanism and safety edges of the door.

- ▶ Only use the operator when you have a direct view of the door.
- ▶ All danger zones must be visible during the entire door operation.
- ▶ Always keep the moving door in sight.
- ▶ Keep persons and animals clear of the range of movement of the door.
- ▶ Never put your hand near the door when it is moving or near moving parts. In particular, do not reach into the moving push arm.
- ▶ Do not reach into the ceiling suspension unit when the motor carriage is running along the track.
- ▶ Do not drive through the door until it has opened completely.
- ▶ Never stand under the opened door.

# 15. Maintenance and care



## WARNING

**Danger due to hot surfaces!**  
After frequent operation, parts of the motor carriage or the control unit may become hot. If the cover is removed and hot parts are touched, they may cause burns.

- ▶ Allow the operator to cool down before removing the cover.

## NOTE

The motor carriage is supplied with safety low voltage via the chain and the track. The use of oil or grease will greatly reduce the conductivity of the chain, track and motor carriage. This may result in faults due to inadequate electrical contact. The chain and track are maintenance-free and must not be oiled or greased.

## NOTE

The use of unsuitable cleaning agents may damage the surface of the operator. Clean the operator with a dry lint-free cloth only.

## 15.2 Maintenance schedule

How often?	What?	How?
Once a month	• Test the emergency release	• See Chapter "14.7 Function of the emergency release"
	• Test obstacle detection	• See Chapter "14.4 Obstacle detection"
	• Test photocell	• Interrupt the active photocell while the door is closing. The door must stop and open slightly. If automatic closing is activated, the door opens completely. • If necessary, clean the photocell, see Chapter "15.3 Care"
Once a year	• Test the door and all moving parts	• As directed by the door manufacturer
	• Check screws on door, ceiling or lintel	• Check that screws are tight and tighten if necessary
As needed	• Chain and track	• Maintenance-free
	• Track	• See Chapter "15.3 Care"
	• Clean the housing of the ceiling control unit and motor carriage	• See Chapter "15.3 Care"

# 15. Maintenance and care

## 15.3 Care

### Clean track, motor carriage and ceiling control unit

1. Pull the power plug out of the power outlet.  
If an accumulator has been installed, remove the control unit cover and disconnect the accumulator from the ceiling control unit, see also Chapter "11.11 Installing and removing the accumulator".  
Then check that the power is disconnected.
2. Remove loose dirt with a moist, lint-free cloth:
  - from the motor carriage and the ceiling control unit
  - from the track and the inside of the track
3. If required, install the accumulator in reverse order of removal.  
Connect the operator to the mains voltage.  
Check that the power supply is connected.

### Clean the photocell

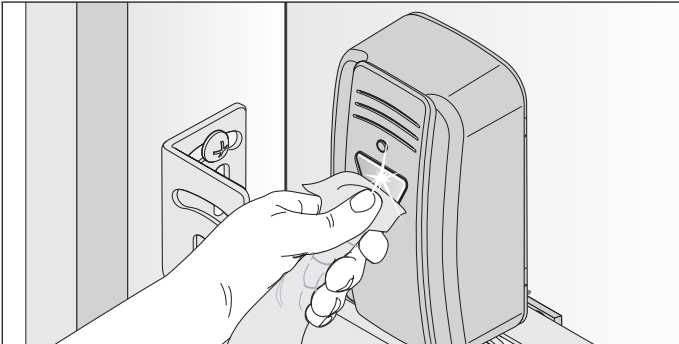

Fig. 1



#### NOTE

**Do not change the position of the photocell when cleaning it.**

1. Clean the housing and reflectors of the photocell with a damp, lint-free cloth.

# 16. Troubleshooting

## 16.1 Safety instructions for troubleshooting

Follow the basic safety instructions listed below.



### **DANGER**

**Danger if not observed!**  
If safety instructions are not observed, serious injury or death may result.

- ▶ All safety instructions must be complied with.



### **DANGER**

**Danger due to electric current!**  
Contact with live parts may result in electric current flowing through the body. Electric shock, burns, or death may result.

- ▶ All work on electrical components must be carried out by a **trained electrician**.
- ▶ Disconnect the mains plug before working on the operator.
- ▶ If an accumulator is connected, disconnect it from the control unit.
- ▶ Check that the operator is not live.
- ▶ Secure the operator against being switched back on.



### **WARNING**

**Danger of falling!**  
Unsafe or defective ladders may tip and cause serious or fatal accidents.

- ▶ Use only a non-slip, stable ladder.
- ▶ Ensure that ladders are safely positioned.



### **WARNING**

**Danger for trapped persons!**  
Persons may be trapped inside the garage. If trapped persons cannot free themselves, severe injury or death may result.

- ▶ Test the operation of the emergency release regularly from inside and if necessary, also from outside.
- ▶ You must have faults repaired professionally without delay.



### **WARNING**

**Danger due to falling parts!**  
Parts of the door may become detached and fall. Persons may be hit. Severe injuries or death may result.

- ▶ Always keep the moving door in sight.
- ▶ Keep all persons and animals away from the door until it is completely opened or closed.
- ▶ Do not drive through the door until it has opened completely.



### **WARNING**

**Danger of entrapment!**  
Loose clothing or long hair may be trapped by moving parts of the door.

- ▶ Keep clear of the moving door.
- ▶ Always wear tight-fitting clothing.
- ▶ Wear a hairnet if you have long hair.

# 16. Troubleshooting



## WARNING

**Danger of crushing and shearing!** If the door moves and there are persons or animals in the movement area, crushing and shearing injuries may be caused by the mechanism and safety edges of the door.

- ▶ Only use the operator when you have a direct view of the door.
- ▶ All danger zones must be visible during the entire door operation.
- ▶ Always keep the moving door in sight.
- ▶ Keep persons and animals clear of the range of movement of the door.
- ▶ Never put your hand near the door when it is moving or near moving parts. In particular, do not reach into the moving push arm.
- ▶ Do not reach into the ceiling suspension unit when the motor carriage is running along the track.
- ▶ Do not drive through the door until it has opened completely.
- ▶ Never stand under the opened door.



## WARNING

**Danger due to optical radiation!** Looking into an LED at short range for an extended period may cause optical glare. This may temporarily reduce vision. This may cause serious or fatal accidents.

- ▶ Never look directly into an LED.



## WARNING

**Danger due to hot surfaces!** After frequent operation, parts of the motor carriage or the control unit may become hot. If the cover is removed and hot parts are touched, they may cause burns.

- ▶ Allow the operator to cool down before removing the cover.



## NOTE

If the door is not in view and the radio remote control is actuated, objects in the movement area of the door may be jammed and damaged. Objects must not be in the range of movement of the door.



## INFORMATION

The control unit detects a short-circuit between chain and track and then switches the operator off.

## 16.2 Troubleshooting

The following guide to troubleshooting lists potential problems and their causes and information on correcting them. In some cases, other chapters and sections with a more detailed description are referenced. You will be prompted to call a **qualified specialist** if this is required. Work on the electrical system and live parts must be performed by a **trained electrician**.

1. Pull the power plug out of the power outlet.  
If an accumulator has been installed, remove the control unit cover and disconnect the accumulator from the control unit, see Chapter "7.2 Cover of the ceiling control unit" and Chapter "11.11 Installing and removing the accumulator".  
Then check that the power is disconnected.
2. After working on the operator, if applicable replace the accumulator in reverse order.
3. Re-connect the operator to the mains voltage.  
Check the power supply.  
⇒ The operator is supplied with mains voltage.

# 16. Troubleshooting





## 16.3 Time sequences of operator lighting in normal mode and in case of faults

The flash sequences show information on malfunctions for technicians, end customers and telephone support.

### In normal mode

Flash sequences	Possible cause	Corrective action
 Operator lighting flashes as warning light	<ul style="list-style-type: none"> <li>• Programming mode activated</li> <li>• Pre-warning time activated</li> <li>• Clearing time activated</li> <li>• Reversing movement, soft reversing and stopped after a soft and reversing movement</li> </ul>	<ul style="list-style-type: none"> <li>• none, for information</li> </ul>

### In the event of faults

Flash sequences	Possible cause	Corrective action
<b>Requirement</b>  Operator expects a command	<ul style="list-style-type: none"> <li>• Waiting for a conformation during the position programming movement of door CLOSE end position</li> </ul>	<ul style="list-style-type: none"> <li>• Confirmation of position programming movement</li> </ul>
<b>Alarm</b>  A process has triggered a fault	<ul style="list-style-type: none"> <li>• Photocell or safety device not OK before movement</li> <li>• Interruption of a safety device during the movement</li> <li>• Dead man movement, safety device not OK</li> <li>• Motor return from outside (e.g. due to attempted break-in)</li> </ul>	<ul style="list-style-type: none"> <li>• Check photocell, realign if necessary</li> <li>• If necessary, have parts replaced by a qualified specialist</li> <li>• Remove obstacle</li> <li>• Have it checked by a qualified specialist</li> <li>• For information</li> </ul>
<b>Service</b>  A process has triggered a fault	<ul style="list-style-type: none"> <li>• Service required (service days, service cycles have been reached)</li> <li>• It may be that after 180 days, the basic force curve data for the door operation vary from the actual data</li> <li>• Motor temperature is too high (overheating)</li> <li>• Programming of difficult positions in case of reversing with no visible cause. The complete distance is traversed from end position to end position (dead man by radio, under direct view only)</li> </ul>	<ul style="list-style-type: none"> <li>• Have the service performed by a qualified specialist</li> <li>• Check weight-balancing and door mechanism</li> <li>• If necessary, carry out force reset, see Chapter "12.10 Reset", section "Deleting the force values"</li> <li>• Allow motor to cool</li> <li>• For information</li> </ul>
<b>Fault</b>  Operator or parts of the operator faulty	<ul style="list-style-type: none"> <li>• Self-test of electronics</li> <li>• Blockage detection (gear breakage, Hall sensor fault)</li> <li>• Limit switch does not operate (e.g. wire break, limit switch fault)</li> <li>• Counting pulses sent in the wrong direction (motor cable was incorrectly connected)</li> <li>• Run time exceeded</li> </ul>	<ul style="list-style-type: none"> <li>• Have it checked and, if necessary, parts replaced by a qualified specialist</li> <li>• Have cable connections checked and, if necessary, parts replaced by a qualified specialist</li> <li>• Check wiring, correct if necessary</li> <li>• Path too long, path restricted to max. 7500 mm</li> </ul>

# 16. Troubleshooting

## 16.4 Troubleshooting table

Problem	Possible cause	Test/check	Remedy
The operator opens the door when the transmitter or command device is actuated but does not close it.	• Photocell and safety device interrupted	• Check photocell and safety devices	• Remove obstacle • The photocell must be aligned • Have it checked and replaced by a qualified specialist
	• Automatic closing function activated	• Wait to see whether the operator starts automatically after 30 seconds	• Automatic closing function deactivated • Have the cause corrected by a <b>trained electrician</b>
Operator cannot be operated with the command device.	• No power	• Check power supply	• Check the power outlet with a different device, for example by plugging in a lamp
	• Limit switch on motor carriage defective	• Unlock operator and push motor carriage to the centre of the track • Lock operator • Actuate transmitter • If the operator now still closes the door but does not open it, the limit switch is defective	• Have the limit switch replaced by a qualified specialist
	• The operator was deactivated by the emergency release mechanism	• Check that the door can be moved manually	• Pull the emergency release handle to activate the operator
	• Command device incorrectly connected to the operator	• Check function of operator with a transmitter	• Check wiring, correct if necessary
	• Transmitter defective	• Operator cannot be started with the transmitter	• Check transmitter power supply • If necessary, replace the battery of the transmitter • If necessary, replace the transmitter with a new one
	• Operator defective	• Operator cannot be started with the transmitter or the connected command device	• Have operator repaired or replaced by a qualified specialist
	• Electrical supply voltage outside the approved range	• Have the mains voltage checked by a <b>trained electrician</b>	• Have the cause corrected by a <b>trained electrician</b>
When a button on the transmitter is pressed, the operator does not open or close the door.	• Transmitter not programmed	• Radio LED does not light up when the transmitter is operated	• Programme transmitter
	• Battery in the transmitter is flat		• Replace the battery of the transmitter
	• Transmitter defective	• LED on transmitter does not light up	• Replace transmitter
Radio command cannot be programmed.	• Memory full	• All four LEDs for radio flash cyclically for about 3 seconds	• Memory full, see Chapter <b>"10.7 Deleting a transmitter button from the radio channel"</b>
Operator stops the door during closing and opens it partially or completely.	• Door has detected an obstacle	• Check whether there are any obstacles in the movement range of the door.	• Remove obstacle • If necessary, have door mechanism checked and set by a qualified specialist
	• Photocell was interrupted	• Check LEDs on photocell.	• Remove obstacle
	• Photocell defective or misaligned		• Align photocell • Check wiring • If necessary, replace photocell

# 16. Troubleshooting

Problem	Possible cause	Test/check	Remedy
<b>Operator stops while the door is opening.</b>	<ul style="list-style-type: none"> <li>• Door has detected an obstacle</li> </ul>	<ul style="list-style-type: none"> <li>• Check whether there are any obstacles in the movement range of the door.</li> <li>• Check the weight balance of the door - it must run smoothly.</li> </ul>	<ul style="list-style-type: none"> <li>• Remove obstacle</li> <li>• If necessary, have door mechanism checked and repaired by a qualified specialist</li> </ul>
<b>Operator lighting or the Lumi base+ supplemental lighting does not work</b>	<ul style="list-style-type: none"> <li>• Operator lighting defective</li> <li>• Lumi base+ supplemental lighting defective</li> </ul>		<ul style="list-style-type: none"> <li>• Have motor carriage replaced with a new one by a qualified specialist</li> <li>• If necessary, retrofit Lumi base+ supplemental lighting</li> </ul>
<b>Speed varies while opening and closing the door</b>	<ul style="list-style-type: none"> <li>• Track dirty</li> </ul>		<ul style="list-style-type: none"> <li>• Clean with a moist lint-free cloth</li> <li>• See Chapter "15.3 Care"</li> </ul>
	<ul style="list-style-type: none"> <li>• Chain tightened incorrectly</li> </ul>		<ul style="list-style-type: none"> <li>• Tighten the chain, see Chapter "6.3 Installation of the operator system"</li> </ul>

## 16.5 Replacing the motor carriage

The instructions for "**Disassembling the motor carriage**" can be downloaded from **SOMMER** at: [www.sommer.eu](http://www.sommer.eu)

If applicable, save the existing settings on the existing motor carriage via SOMlink and a WiFi-enabled device. The settings can be transferred to the new motor carriage later.

The new motor carriage is in delivery condition from the factory. After replacing the motor carriage, make sure that used accessories have been transferred to the new motor carriage.

Initial operation must be repeated and the special functions of the motor carriage reset, see Chapter "**9. Initial operation**" and "**10. Connections and special functions of the motor carriage**".

Handheld transmitters which are used must also be reprogrammed, see Chapter "**10.5 Programming the transmitter**".

On the other hand, the transmitter does not have to be programmed if the Memo accessory part has already been used. After successful initial operation, carry out a final test and a function test, see Chapter "**13. Function test and final test**".



### INFORMATION

Save the existing settings of the motor carriage with the help of SOMlink and a WiFi-enabled device. After the new motor carriage has been inserted, reinstall the data.





# 17. Taking out of operation, storage and disposal

## 17.1 Taking the operator out of operation and disassembly

Follow the basic safety instructions listed below.

People under the influence of drugs, alcohol, or medications that can influence their ability to react may **not** work on the operator.

Disassembly of the operator may only be performed by a **qualified specialist**.

This Installation and Operating Manual must be read, understood and complied with by a qualified specialist who dismantles the operator.



### **DANGER**

**Danger if not observed!**  
If safety instructions are not observed, serious injury or death may result.

- ▶ All safety instructions must be complied with.



### **DANGER**

**Danger due to electric current!**  
Contact with live parts may result in electric current flowing through the body. Electric shock, burns or death will result.

- ▶ All disassembly work on electrical components must be carried out by a **trained electrician**.
- ▶ Disconnect the power plug before disassembling the operator.
- ▶ If an accumulator is connected, disconnect it from the control unit.
- ▶ Check that the operator is not live.
- ▶ Secure the operator against being switched back on.



### **WARNING**

**Danger of falling!**  
Unsafe or defective ladders may tip and cause serious or fatal accidents.

- ▶ Use only a non-slip, stable ladder.
- ▶ Ensure that ladders are safely positioned.



### **WARNING**

**Danger of tripping and falling!**  
Unsafely positioned parts such as packaging, operator parts or tools may cause trips or falls.

- ▶ Keep the disassembly area free of unnecessary items.
- ▶ Place all parts where no-one is likely to trip or fall over them.
- ▶ The general workplace guidelines must be observed.



### **WARNING**

**Danger due to optical radiation!**  
Looking into an LED at short range for an extended period may cause optical glare. This may temporarily reduce vision. This may cause serious or fatal accidents.

- ▶ Never look directly into an LED.



### **WARNING**

**Danger due to hot surfaces!**  
After frequent operation, parts of the motor carriage or the control unit may become hot. If the cover is removed and hot parts are touched, they may cause burns.

- ▶ Allow the operator to cool down before removing the cover.



### **WARNING**

**Risk of eye injury!**  
Eyes and hands may be seriously injured by chips when removing screws.

- ▶ Wear safety glasses.



### **WARNING**

**Risk of injury in the head region!**  
Impact with suspended objects may cause serious abrasions and cuts.

- ▶ You must wear a safety helmet when disassembling suspended parts.



# 17. Taking out of operation, storage and disposal



## CAUTION

**Risk of injury to hands!**  
Rough, projecting metal parts may cause abrasions and cuts when touched.

- ▶ Wear safety gloves.



## NOTE

If there is an accumulator in the control unit, it must be removed by a trained electrician. See Chapter "11.11 Installing and removing the accumulator".

The operator and its accessories must be disconnected from electrical power when putting them out of operation or during disassembly.

1. Pull the power plug out of the power outlet.  
If an accumulator has been installed, remove the control unit cover and disconnect the accumulator from the control unit. See also Chapter "11.11 Installing and removing the accumulator". Then check that the power is disconnected.
2. Disassembly is in reverse order of installation.

## 17.2 Storage

Store the packaging units as follows:

- in enclosed, dry rooms so that they are protected from moisture
- at a storage temperature from  $-25\text{ °C}$  to  $+65\text{ °C}$
- secure to prevent falling
- leave room for unhindered passage

## NOTE

Improper storage may damage the operator.  
The operator must be stored in closed and dry rooms.

## 17.3 Disposal of waste

Observe the instructions for disposal of packaging, components, batteries and, if applicable, the accumulator.



## DANGER

**Danger of hazardous substances!**  
Improper storage, use or disposal of accumulators, batteries and operator components are dangerous for the health of humans and animals. Serious injury or death may result.

- ▶ Accumulators and batteries must be stored out of the reach of children and animals.
- ▶ Keep accumulators and batteries away from chemical, mechanical and thermal influences.
- ▶ Do not recharge old accumulators and batteries.
- ▶ Components of the operator as well as old accumulators and batteries must not be disposed of with household waste. They must be disposed of properly.

## NOTE

Dispose of all components in accordance with national regulations to avoid environmental damage.

# 17. Taking out of operation, storage and disposal

---



## INFORMATION



All components that have been taken out of service must not be disposed of with normal waste. Unwanted components with pollutants must be disposed of correctly at an authorised recycling centre. The local regulations must be observed.



## INFORMATION



Old accumulators and batteries must not be disposed of with household waste, as they contain hazardous substances. These must be disposed of properly at municipal collection points or in the containers provided by dealers. The local and national regulations must be observed.

## 18. Short instructions for installation

---

The short instructions do not replace the installation and operating manual.

Read this Installation and Operating Manual carefully and, most importantly, follow all warnings and safety instructions.

This will ensure that you can install the product safely and optimally.

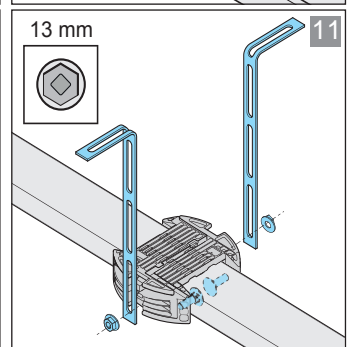
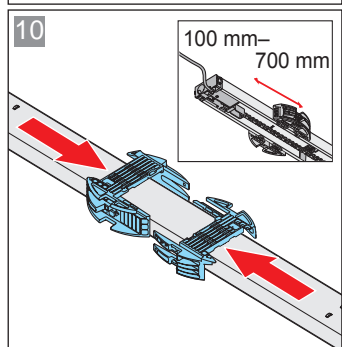
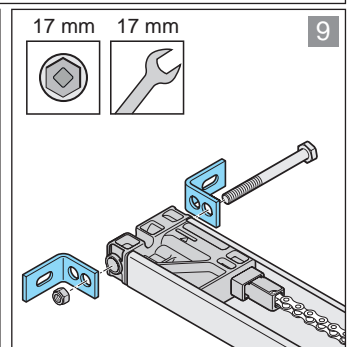
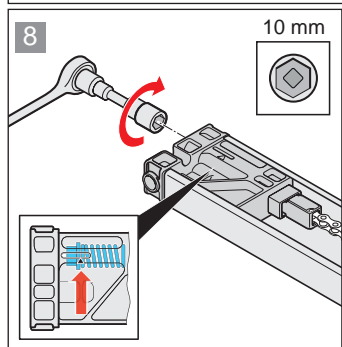
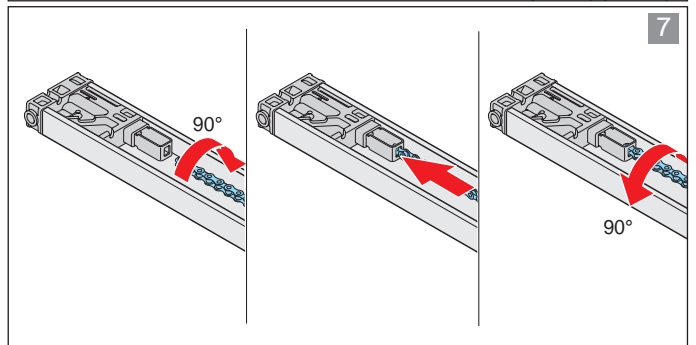
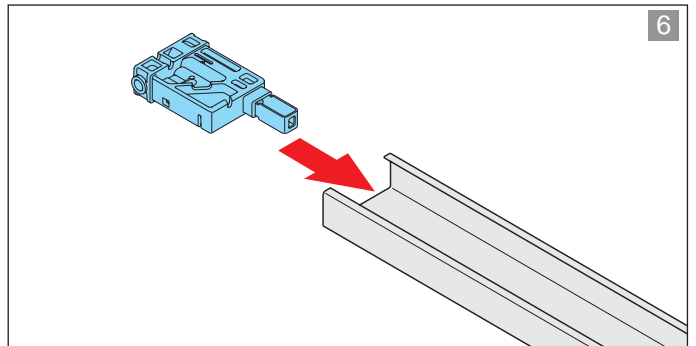
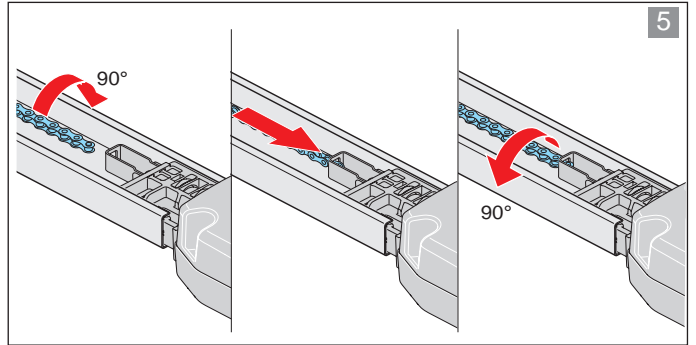
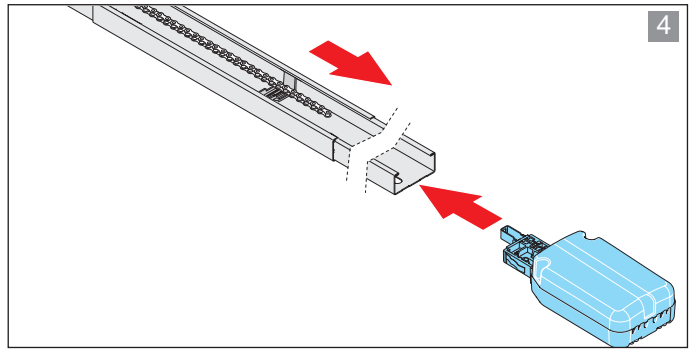
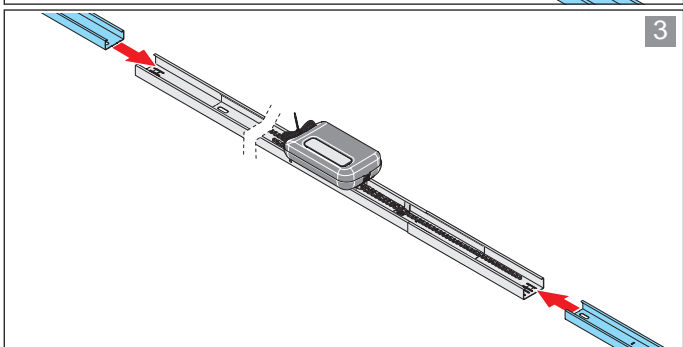
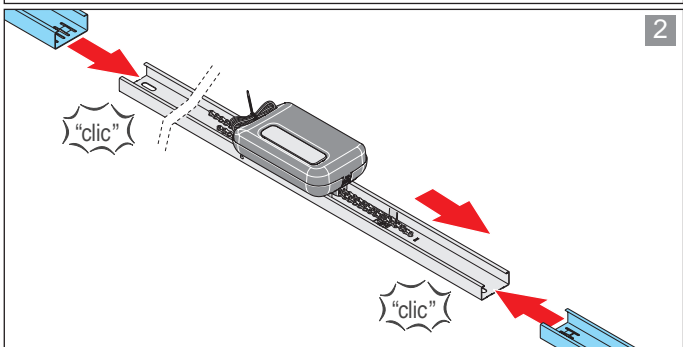
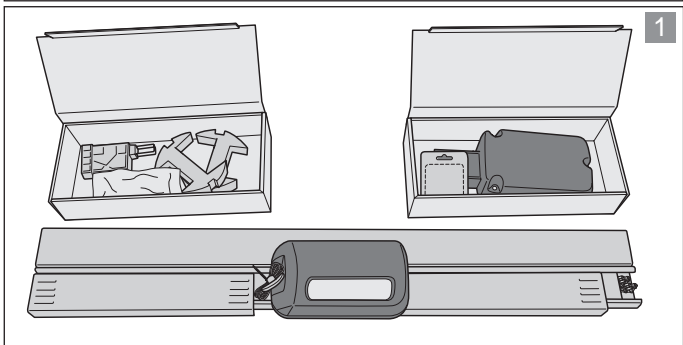
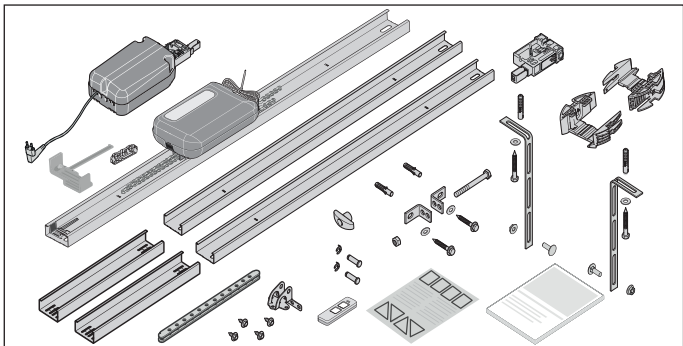
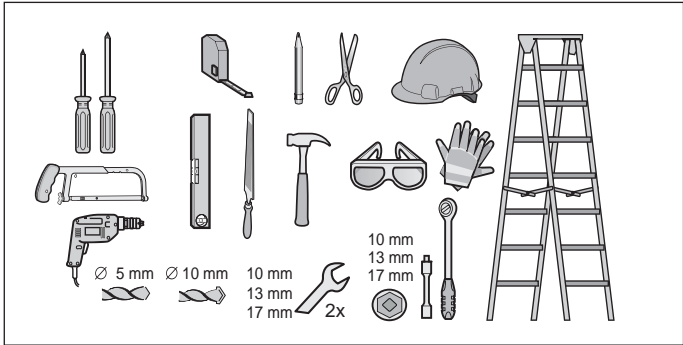
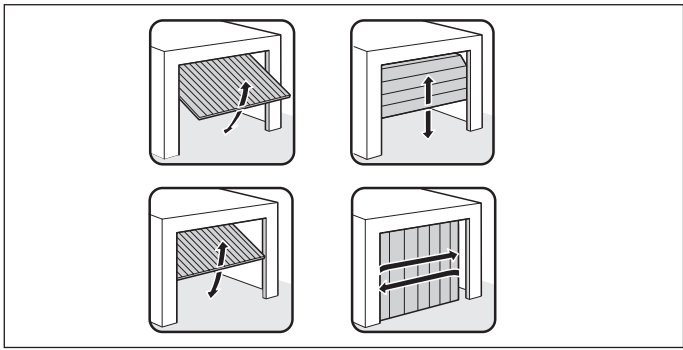

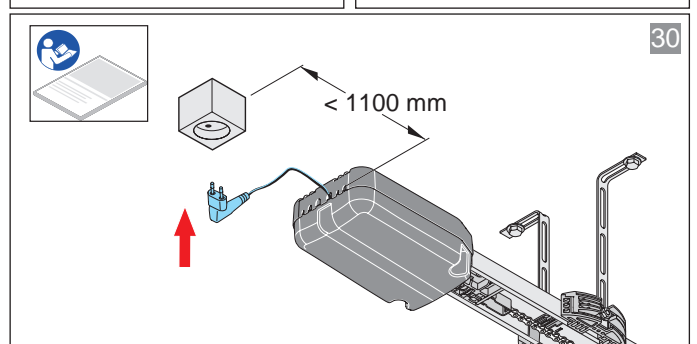
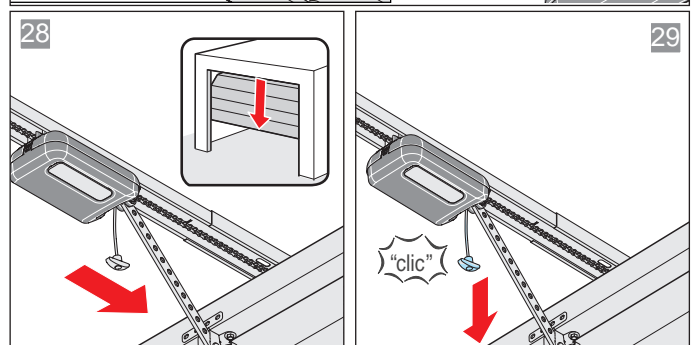
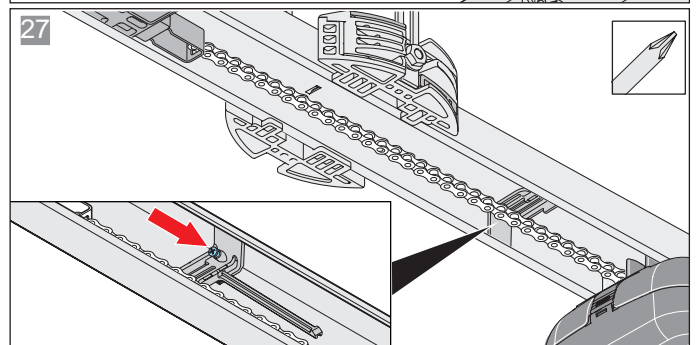
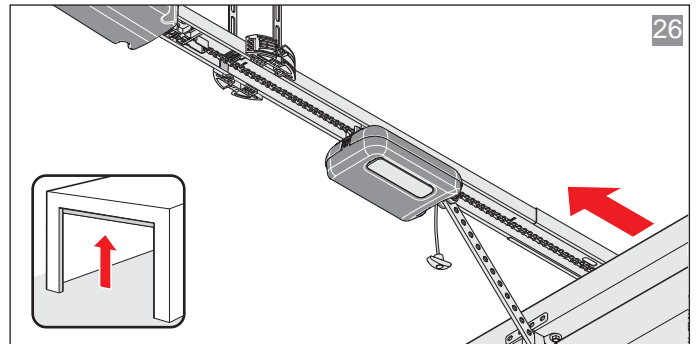
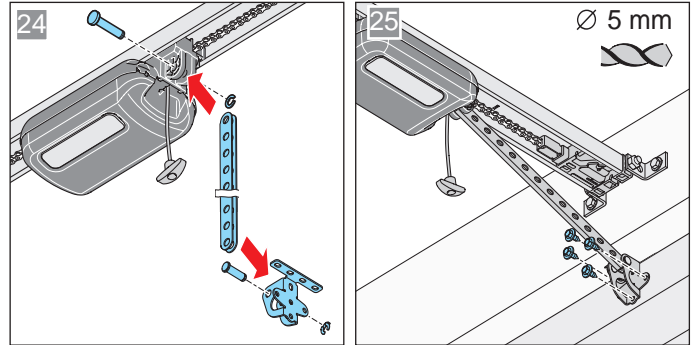
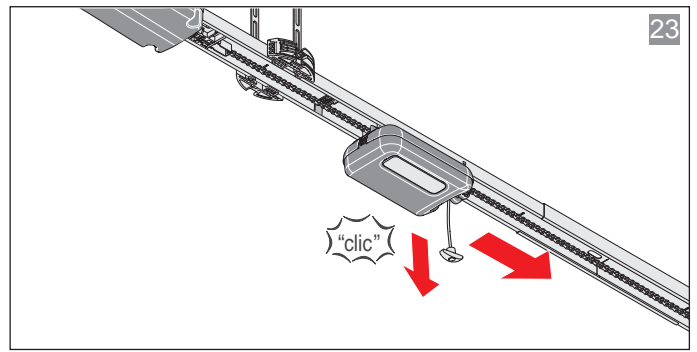
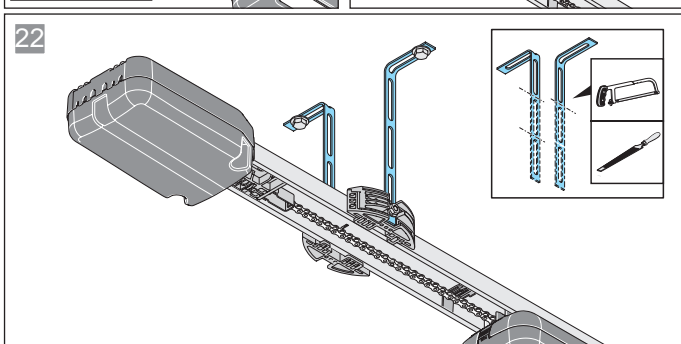
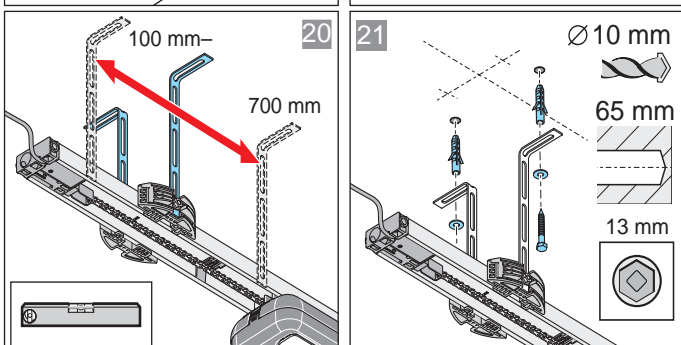
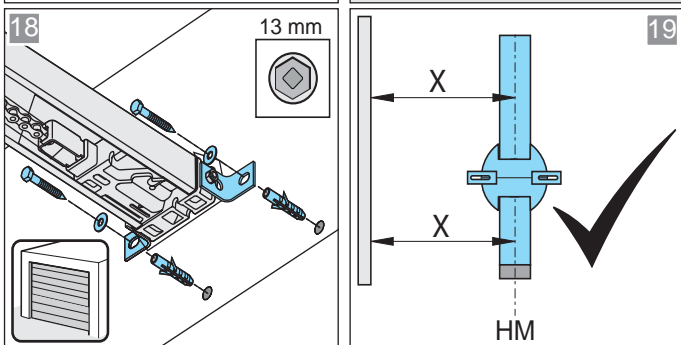
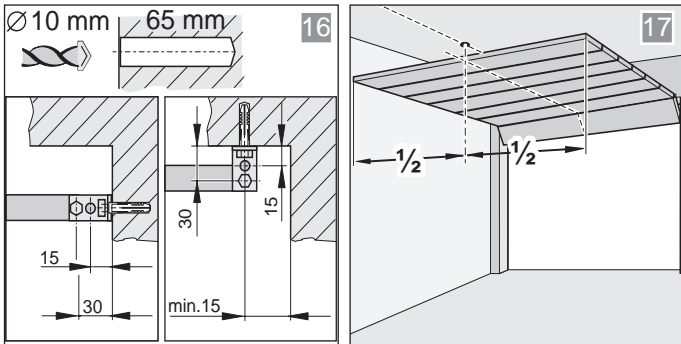
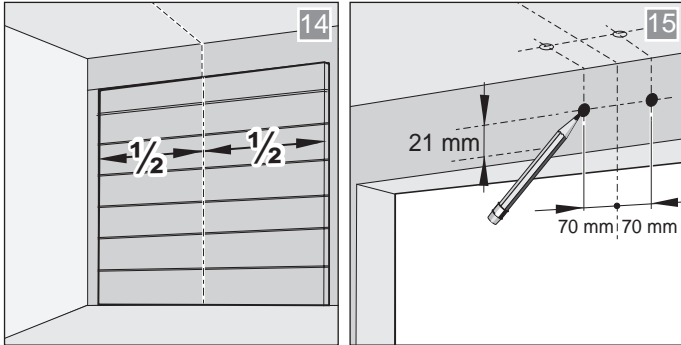
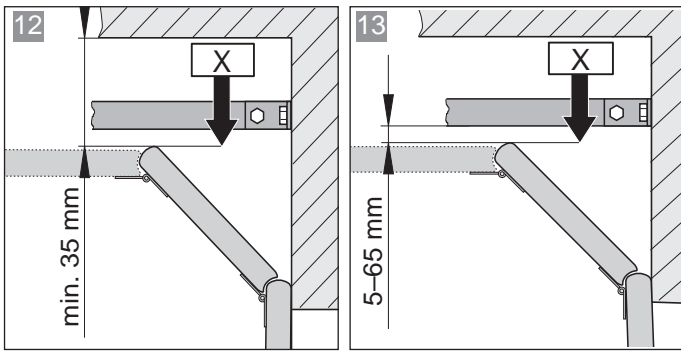



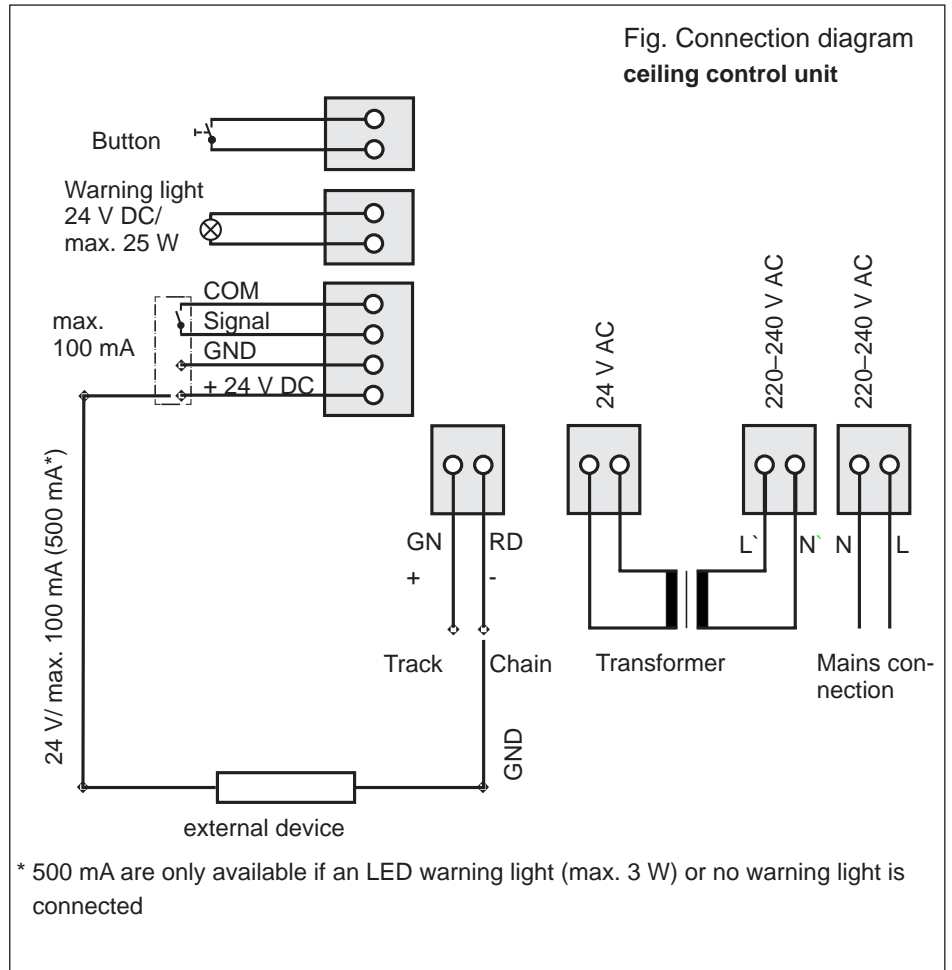
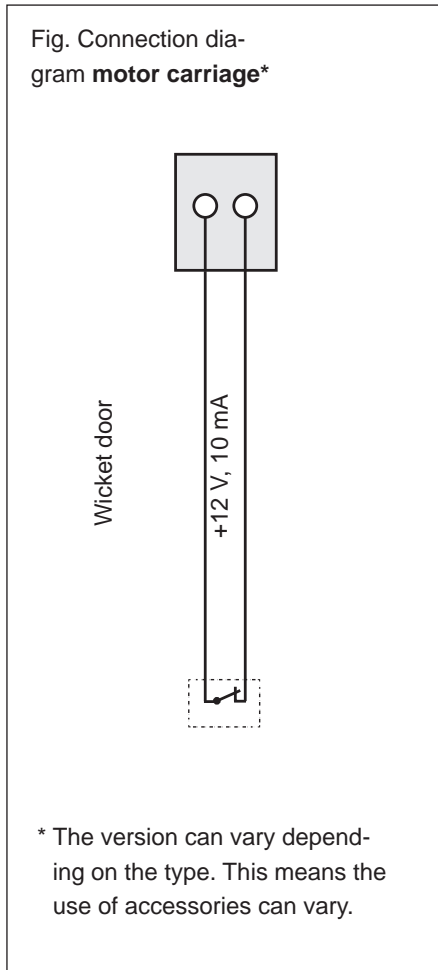



# 19. Connection diagrams and functions of the DIP switches for A 550 L and A 800 XL

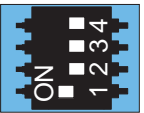
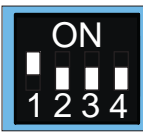
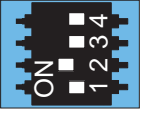
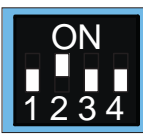
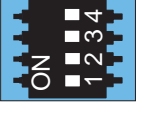
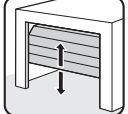

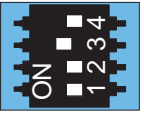
When connecting external devices, power-saving mode must be deactivated to ensure the power supply.

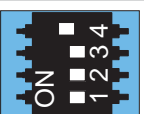
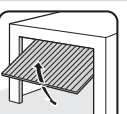
DIP switches on the motor carriage	ON	OFF 	DIP switches on the ceiling control unit	ON	OFF 
	• Automatic closing function activated	• Automatic closing function deactivated		• "Conex" additional circuit board • T1 defines door OPEN • T2 defines door CLOSE	• "Conex" additional circuit board • T1 pulse sequence • T2 lighting function/partial opening
	• Partial opening activated/lighting function deactivated	• Partial opening deactivated/lighting function activated		• Relay is activated during door movement and if the door is not closed*	• Lighting function
				• Continuous power to the complete system activated	• Power-saving mode activated
				• COM and Signal activated as button input (partial opening)	• COM and Signal activated as safety contact for photocell
					

E.g.: Door status display

**APERTO Torantriebe GmbH**

Hans-Böckler-Straße 29  
D-73230 Kirchheim/Teck  
Germany



+49 (0) 7021 9447-0



+49 (0) 7021 9447-25

[info@aperto-torantriebe.de](mailto:info@aperto-torantriebe.de)

[www.torantriebe.de](http://www.torantriebe.de)

© Copyright 2017 All rights reserved