



As of date of
 manufacture, meets all
 ANSI/UL 325 Safety
 Requirements for
 Vehicular Garage
 Door Operators



CHALLENGER 9000M SERIES

Residential Vehicular Garage Door Operator

MODEL NUMBERS 9300M, 9500M, and J9500M

INSTALLATION AND OWNER'S MANUAL

INSTALLER: Place this manual in the plastic envelope provided and permanently attach to the wall near the pushbutton.

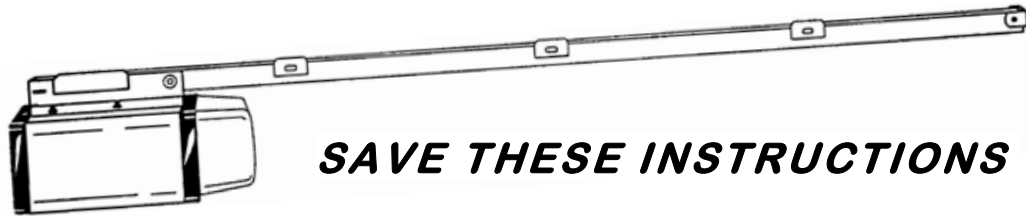

SAVE THESE INSTRUCTIONS



110060

READ THIS MANUAL CAREFULLY BEFORE INSTALLATION OR USE

★ TABLE OF CONTENTS

Product Features	2	Pre-Power On Installation Checklist	14
Tools Required.....	2	Section E: Operation & Adjustments.....	15
Component Identification	3	Important Safety Instructions	15
A: Assembly Instructions	3	Turning on the Power	15
Identify Your Door Type	4	Basic Operating Parameters	15
B: Important Installation Instructions.....	5	Manual Door Operation.....	9
C: Installing the Operator	6	Adjustments	16
Mounting the Front Bracket.....	6	Opening Travel Adjustments.....	16
Mounting the Power Head	7	Open & Closing Force Adjustment	16
Door Bracket Installation.....	7	Setting The Close Limit	16
Door Arm Installation.....	8	Obstruction Sensing Adjustment.....	16
Connecting Electrical Power	9	Testing The Obstruction Sensing	17
The Convenience Lamp	9	Positive Mechanical Lock Adjust.....	18
D: Control & Auxiliary Equipment.....	10	Alignment of Safe Finish Photoelectric	18
Standard Wall Button Installation	10	Photoelectric Obstruction Test	18
Programming the Radio Transmitter	11	Wiring Diagram.....	19
Programming the Radio Receiver	13	Troubleshooting Guide	19
Safe Finish™ Photosystem Installation.....	13	Warranty Information	20

READ THESE STATEMENTS CAREFULLY AND FOLLOW THE INSTRUCTIONS CLOSELY

The Warning and Caution boxes throughout this manual are there to protect you and your equipment.

Pay close attention to these boxes as you follow the manual.

 WARNING	 CAUTION	 WARNING	 CAUTION
<p>Indicates a MECHANICAL hazard of INJURY OR DEATH. Gives instructions to avoid the hazard.</p>	<p>Indicates a MECHANICAL hazard of DAMAGE to the door, door operator, or equipment. Gives instructions to avoid the hazard.</p>	<p>Indicates an ELECTRICAL hazard of INJURY OR DEATH. Gives instructions to avoid the hazard.</p>	<p>Indicates an ELECTRICAL hazard of DAMAGE to the door, door operator, or equipment. Gives instructions to avoid the hazard.</p>

The purpose of this booklet is to provide assembly, installation and operation information concerning the herein described Residential Garage Door Opener and related Accessory Products.

NOTICE

IT IS IMPORTANT THAT THIS INSTRUCTION MANUAL BE READ AND UNDERSTOOD COMPLETELY BEFORE INSTALLATION OR OPERATION IS ATTEMPTED.

NOTICE

THE IMPORTANT SAFEGUARDS AND INSTRUCTIONS IN THIS MANUAL CANNOT COVER ALL POSSIBLE CONDITIONS AND SITUATIONS WHICH MAY OCCUR DURING ITS USE. IT MUST BE UNDERSTOOD THAT COMMON SENSE AND CAUTION MUST BE EXERCISED BY THE PERSON(S) INSTALLING, MAINTAINING AND OPERATING THE EQUIPMENT DESCRIBED HEREIN. DO NOT USE THIS EQUIPMENT FOR ANY OTHER THAN ITS INTENDED PURPOSE - OPERATING OVERHEAD GARAGE DOORS.

STANDARD FEATURES:

Digital Radio Controls: This opener is equipped with a pre-programmed transmitter to one of over nineteen thousand private codes. The transmitter can be re-programmed without difficulty using the external operation buttons. The power head is easily programmed to accept the transmitter signal. (Page 11)

Safe Finish™ Photosystem: An invisible infrared beam of light guards the door opening and reverses a downward moving door if the beam is broken by a stationary or moving object. The opener's motor control circuitry constantly monitors the Safe Finish Photosystem for proper operation.

Alternating Action Operation: The mechanical wall push button functions in an Open/Stop/Close/Stop-Reverse to Open mode in normal operation. (Page 15)

Manual Release: A pull cord allows separation of the drive mechanism and manual operation of the door when desired, as in the event of a power failure. (Page 9)

Automatic Reconnection: Once power is restored, or automatic operation of the door is again desired, initiating operation in the normal manner (Push Button, Radio Control, etc.) will effect automatic reconnection of the Manual Release Mechanism. (Page 9)

Sensing System: A built-in sensing system detects obstructions during door operation. If in the downward (close) travel mode, the Opener will sense an obstruction and reverse the direction of the door. In the open mode, the opener will stop. Since all doors are different, the Sensing System has independent adjustments for customizing the level of force required for the normal opening and closing of specified doors. (Page 16)

Close Limit Switch: In winter months it's common for small pieces of ice or packed snow to be trapped under the door. Ground swelling can also effect the close limit setting of the opener. The opener's Close Limit Switch overrides the Sensing System during the last one inch of closing travel and prevents the door from reversing if it encounters an obstruction at this point.

Constant Contact To Close: For utmost safety and security, the standard operation mode requires constant contact on the mechanical Push Button to close the door if the Safe Finish™ Photosystem becomes misaligned or if there is an irregularity in the wiring to the device. In this mode of operation, a Radio Transmitter cannot be used to close the door. (Page 18)

OPTIONAL FEATURES:

Keyless Entry System: A tamper resistant outdoor keypad, the optional Keyless Entry System permits entry to the garage without use of key or radio transmitter. Easily programmable, it accommodates a four digit PIN code (10,000 possible codes). Lighted Buttons enhance nighttime use.

★ **TOOLS REQUIRED FOR INSTALLATION**

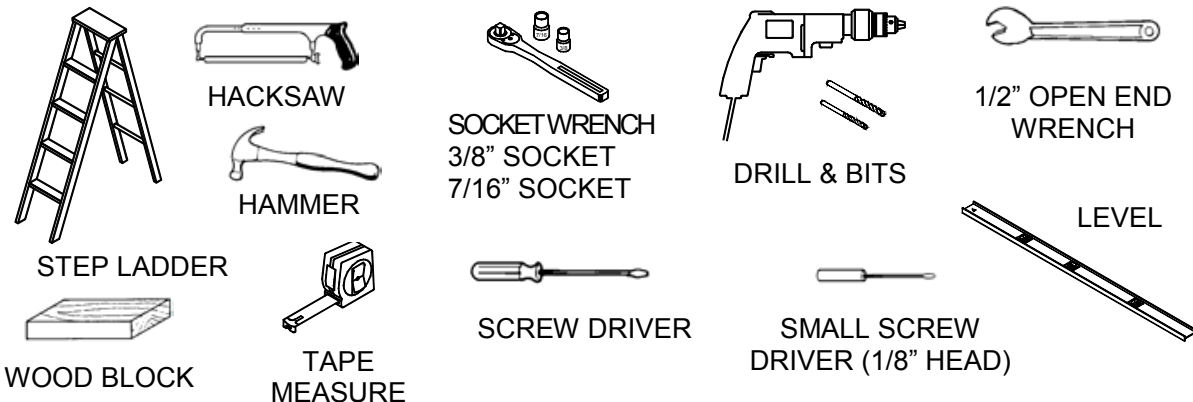

3

COMPONENT IDENTIFICATION

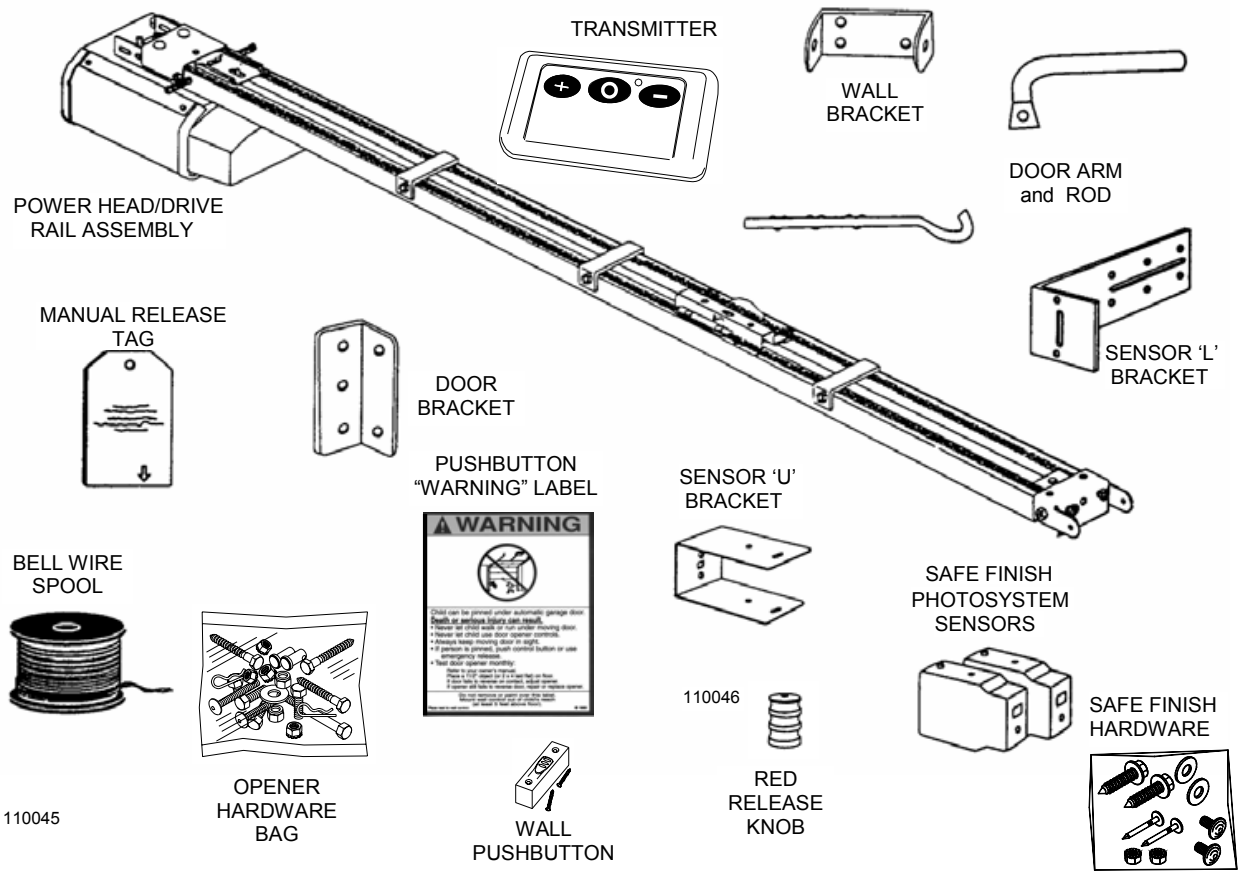

A: ASSEMBLY INSTRUCTIONS

110047-1

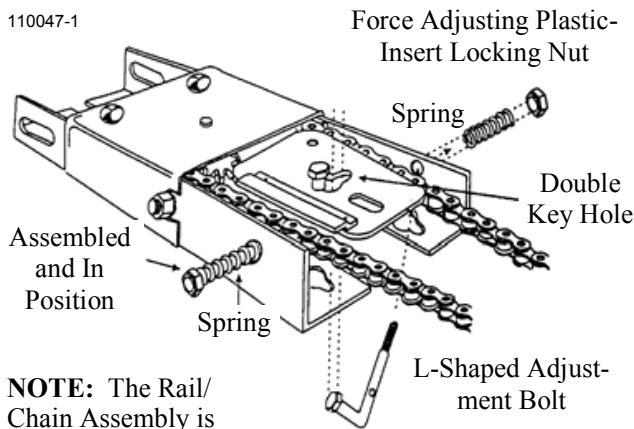

NOTE: The Rail/Chain Assembly is packaged separately from the Power Head Unit. The trolley, front idler/tension adjustment assembly, chain, drive gear and limit cams are assembled to the Rail/Chain Assembly at the factory. Follow the steps outlined below to complete assembly prior to installation. Refer to the component identification illustrations on the previous page.

STEP 1: Prior to attaching the motor drive unit to the rail assembly, the Open and Close adjustment bolts must be installed. Place the threaded end of the adjustment bolt through the hole in the rail and then slip the head of the bolt through the center of the double key hole. Slide the spring over the bolt and attach load adjusting nut. Tighten until the tip of the bolt extends 3/16" outside the nut. Repeat above for the other side.

STEP 2: Protect the Power Unit cover from scratching during assembly by placing it on cardboard. Loosen the two 5/16" lock washer nuts on top of the power head drive unit.

STEP 3: VERY IMPORTANT! Position a paper shim around the power head unit drive gear (standard weight paper, see illustration). Shim must remain in place while assembling the power head unit to the Rail/Chain assembly to ensure a proper gear mesh and avoid excessive long term wear.

STEP 4: Align the four key holes in the Rail/Chain assembly with the two front guide tabs and the two rear bolt studs on the power head unit and place the rail/chain assembly in place over the power head unit.

5/16" Lock Washer Nuts 110047-3

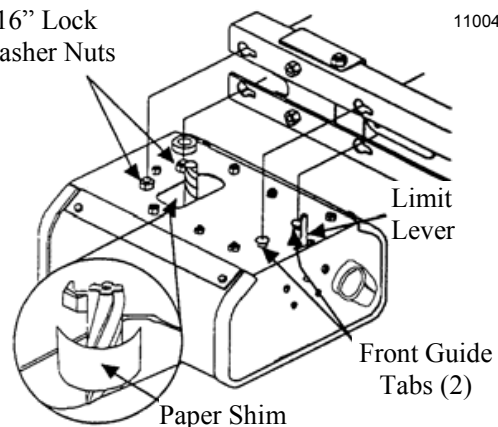

★ ASSEMBLY INSTRUCTIONS

The power head drive unit limit lever protrudes up through the rail/chain assembly sensing plate. Take care not to bend the lever when assembling. Slide the power head drive unit forward until the gear meshes with the rail/chain assembly drive gear. Check to make sure the

front guide tabs on the power head unit are securely locked on the rail/chain assembly.

STEP 5: The power head drive unit should be move forward until all play between the gears has been eliminated, but no additional force should be used that could cause pressure on the motor (power head unit) drive gear. Tighten the two 5/16" lock washer nuts on top of the power head drive unit that were loosened in Step 2 above.

When the opener is first activated the paper shim will be ejected. The paper shim should have the profile of the gears to indicate the proper mesh between them.

STEP 6: Recheck the nuts used to secure the Rail/Chain assembly to the Power Head Unit, making sure they are tight.

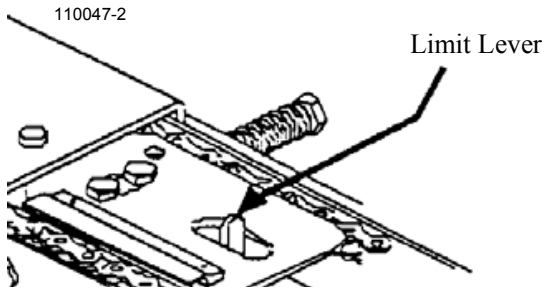

Take care not to bend limit lever

Assembly is now complete and you are ready to begin installation of the opener.

★ DOOR TYPE IDENTIFICATION

IMPORTANT!

IDENTIFY YOUR DOOR TYPE FROM THOSE ILLUSTRATED BELOW AND FOLLOW INSTRUCTIONS FOR THAT TYPE OF DOOR

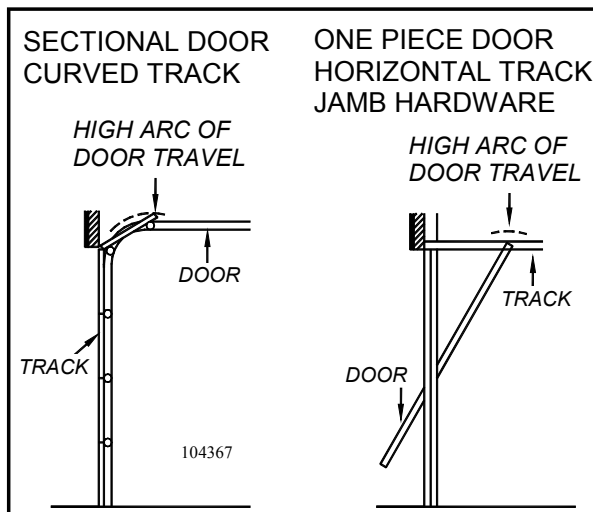

FOR THESE TYPES OF DOORS USE MODEL 9300M OR MODEL 9500M. USE 7 FT, 8 FT OR 10 FT RAIL (MATCH DOOR HEIGHT)

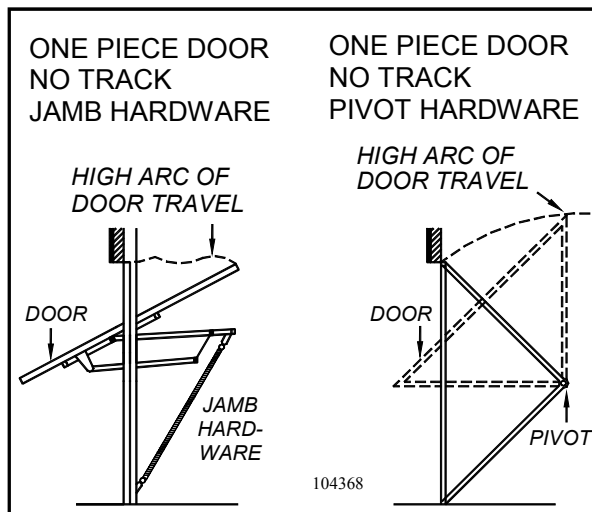

FOR THESE TYPES OF DOORS USE MODEL J9500M. USE 7J RAIL (FOR DOOR HEIGHT UP TO 8 FT)



SPRINGS, PULLEYS, CABLES AND MOUNTING HARDWARE USED TO BALANCE YOUR GARAGE DOOR ARE UNDER EXTREME TENSION AT ALL TIMES AND CAN CAUSE SEVERE INJURY OR DEATH IF DISTURBED. DO NOT ATTEMPT ADJUSTMENT.

5 B: IMPORTANT INSTALLATION INSTRUCTIONS

 **WARNING! TO REDUCE THE RISK OF SEVERE INJURY OR DEATH READ AND FOLLOW ALL INSTALLATION INSTRUCTIONS!**

AN UNBALANCED DOOR OR ONE THAT STICKS OR BINDS MAY PREVENT THE SENSING SYSTEM FROM WORKING PROPERLY, CAUSING INJURY OR DEATH. ENSURE DOOR IS PROPERLY BALANCED AND ELIMINATE ANY STICKING OR BINDING PRIOR TO INSTALLATION OF OPERATOR. A properly balanced door will open slowly from a 3/4 open position, close slowly from a 3/4 closed position, and remain still at a 1/2 open position. If the door is not properly balanced, HAVE A QUALIFIED SERVICE PERSON MAKE REPAIRS TO CABLES, SPRING ASSEMBLIES AND OTHER DOOR HARDWARE BEFORE INSTALLING THE OPENER

YOUR GARAGE DOOR IS THE LARGEST MOVING OBJECT IN YOUR HOUSE, THE SPRINGS, PULLEYS, CABLES AND MOUNTING HARDWARE UTILIZED TO BALANCE ITS OPERATION ARE UNDER EXTREME TENSION AT ALL TIMES AND CAN CAUSE SERIOUS PERSONAL INJURY, EVEN DEATH, IF DISTURBED. DO NOT ATTEMPT ADJUSTMENT. CALL A QUALIFIED SERVICE PERSON TO MOVE, LOOSEN OR ADJUST DOOR SPRINGS OR HARDWARE.

REMOVE ALL ROPES AND REMOVE OR MAKE INOPERATIVE ALL LOCKS CONNECTED TO THE GARAGE DOOR BEFORE INSTALLING THE OPENER.

DO NOT WEAR RINGS, WATCHES OR LOOSE CLOTHING WHILE INSTALLING OR SERVICING GARAGE DOOR OPENERS. WEAR SAFETY GOGGLES OR OTHER PROTECTIVE EYEWEAR.

IF POSSIBLE, INSTALL THE DOOR OPENER 7 FT OR MORE ABOVE THE FLOOR. MOUNT THE EMERGENCY RELEASE 6 FT ABOVE THE FLOOR.

REINFORCE LIGHTWEIGHT FIBERGLASS, ALUMINUM AND STEEL DOOR TOP SECTIONS TO AVOID DAMAGE AND TO INSURE PROPER OPERATION OF THE SAFETY REVERSE SYSTEM. CONTACT YOUR DOOR MANUFACTURER FOR A REINFORCEMENT KIT.

DO NOT CONNECT THE OPENER TO A POWER SOURCE UNTIL INSTRUCTED TO DO SO.

CHECK LOCAL BUILDING AND ELECTRICAL CODES FOR MANDATORY INSTALLATION AND WIRING REQUIREMENTS.

CONNECT POWER CORD ONLY TO A PROPERLY GROUNDED OUTLET. IF PERMANENT WIRING IS REQUIRED BY CODES, DISCONNECT POWER AT FUSE BOX OR CIRCUIT BREAKER BEFORE ATTEMPTING ANY WIRING CONNECTIONS.

LOCATE THE CONTROL PUSH BUTTON:

- WITHIN SIGHT OF THE DOOR, AND,
- AT A MINIMUM HEIGHT OF 5 FT SO SMALL CHILDREN CAN'T REACH IT, AND,
- AWAY FROM MOVING PARTS OF THE DOOR.

INSTALL THE ENTRAPMENT WARNING LABEL NEXT TO THE CONTROL PUSH BUTTON IN A PROMINENT LOCATION. INSTALL THE EMERGENCY RELEASE INSTRUCTION CARD, ATTACHING IT ON OR NEXT TO THE EMERGENCY RELEASE.

ADJUST THE SENSITIVITY ADJUSTMENTS ENOUGH TO ALLOW THE DOOR TO OPERATE, BUT NOT SO FIRMLY AS TO EXERT EXCESSIVE PRESSURE ON AN OBSTRUCTION BEFORE REVERSING.

AFTER INSTALLING THE OPENER, THE DOOR SHOULD REVERSE WHEN IT CONTACTS A 1-1/2" HIGH OBJECT (A PIECE OF STANDARD 2 X 4 BOARD LAID FLAT) ON THE FLOOR.

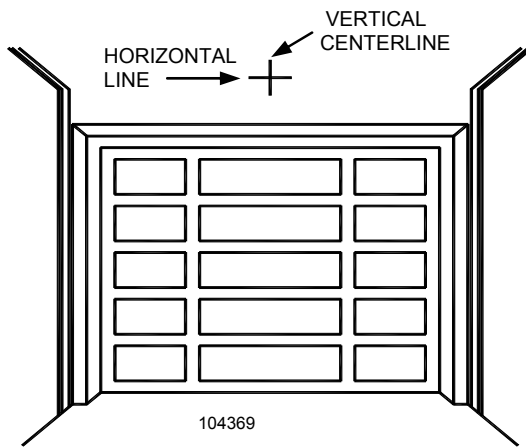

STEP 1: Mounting the Front Bracket —

Sectional Doors and One-Piece Doors with Track (For One-Piece Doors without track see Step 1A, next): Mark a vertical centerline on the header above the door. By manually raising the door, determine the high arc of the door's travel (see illustrations on page 4) and using a level, transfer this measurement to the header (see illustration at left). Draw a horizontal line, crossing the previously drawn centerline, at this point. Install the Front Mounting Bracket securely with the lag screws as illustrated below. If necessary, reinforce the header with steel angle iron or wood to ensure a secure mount.



WARNING

FRONT MOUNTING BRACKET MUST BE INSTALLED TO A STRUCTURAL SUPPORT (STUD) ON THE HEADER WALL. FAILURE TO DO SO COULD CAUSE SENSING SYSTEM TO MALFUNCTION, RESULTING IN ENTRAPMENT, INJURY OR DEATH. REINFORCE HEADER IF NECESSARY USING A WOOD STUD OR ANGLE IRON AND LAG SCREWS (NOT PROVIDED).

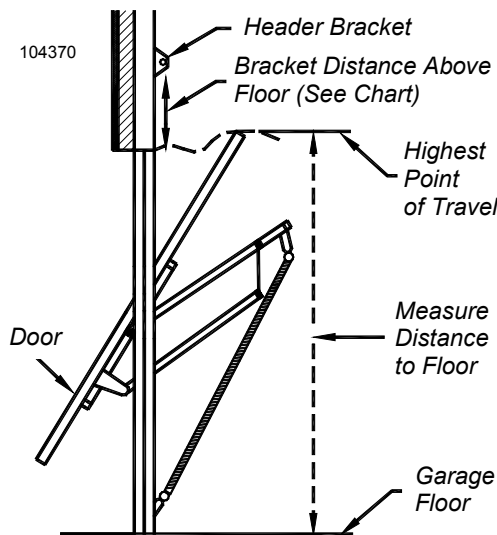

STEP 1A: Mounting the Front Bracket — One Piece Doors Without Track

Mark a vertical centerline on the header above the door. Manually raise the door to its high arc position and temporarily clamp in that position. With the door in this high arc position, measure the distance from the top of the door to the floor (see figure at left). Subtract the actual door height from the high arc distance to the floor. This is the high arc rise of the door. Unclamp and close the door. Using the table below, draw a horizontal line at the appropriate height above the door to intersect with the vertical centerline.

Mount the Front Mounting Bracket securely with lag screws as shown in the figure below. If necessary, reinforce the header with steel angle iron or wood to ensure a secure mount.

HIGH ARC	HORZ. LINE
4 INCHES	8 INCHES
4 TO 8 INCHES	13 INCHES
8 TO 12	18 INCHES

STEP 2: Raise the Tee Rail so that the Front Idler Bracket and Front Mounting Bracket align. Insert bolt and tighten nut loosely for now. Later in the installation, this nut must be tightened securely.

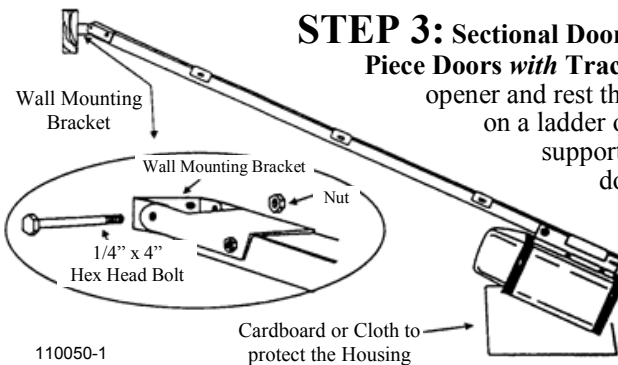

STEP 3: Sectional Doors and One Piece Doors with Track: Raise the opener and rest the Power Unit on a ladder or other sturdy support. Open the

door to the full open position. Allow 2" of space between the Tee Rail and the top section of the door (as shown in the illustration on the top of page 7, left).

STEP 3A: One Piece Doors without Track:

Raise the opener and rest the power unit on a ladder or other sturdy support. Open the door to the high arc

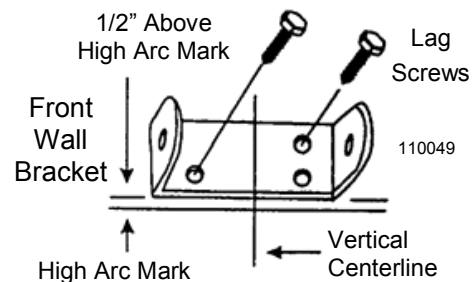

position. Allow 2" of space between the tee rail and the door (at the high arc position) as shown in the illustration on page 9. The opener will be angled as shown. This is necessary for proper operation.

NOTE: Since the opener will be secured permanently in this position, open and close the door a few times to be sure the door does not rub on the Tee Rail and that you have allowed the proper clearances before proceeding.

STEP 4: Mount Power Head to Ceiling: Since there is such variety in ceiling structures, all the mounting possibilities for the Power Unit cannot be illustrated, and attachment to, ceiling joists, a carpenter should be contacted to provide assistance. A cross brace will be necessary if power head is mounted here. The main concern is mounting the Power Unit securely to the ceiling joists for operational strength, rigidity and safety. Although there are a series of mounting slots provided on the power unit, try to **secure the mounting straps in the slots closest to the front.** Mounting may usually be accomplished using standard 1-1/4" perforated steel angle available at most hardware stores. If in doubt about is mounted 8" or more from the ceiling.

STEP 5: Return to the Rail/Wall Mounting Bracket and securely tighten the bolt and nut that connect the Rail Front Idler bracket and the Wall Mounting Bracket. Take care not to over tighten the nut; tighten only until the end of the bolt is (See Step 2).

Mounting The Power Head End of Opener

STEP 6: Align the center of opener tracks with the center line previously marked on the top section of the garage door to ensure rail will be parallel with the direction of door travel.

Use supplied hangers from the ceiling beams to hang the opener at the power head end (be sure to locate and mount to the solid structural beams, as illustrated). Pre-drill with 3/16" drill bit and use supplied 1/4" x 1-1/2" lag screws to ensure a rigid mount.

NOTE: Hanging brackets should be at an angle to provide rigid support. If hangers have no angle or if you use longer hangers, cross brace the hangers to eliminate the possibility of sway during operation of the opener.

 WARNING	<p>Fiberglass, aluminum or lightweight steel garage doors will require reinforcement before installation of the door mounting bracket. Contact your door manufacturer for a reinforcement kit or instructions.</p>
---	---

STEP 7: Door Bracket Installation

NOTE: If the door is of light construction it may be necessary to reinforce the center stile with steel angle or wood to prevent damage to the door if it encounters an obstruction on closing. Mount the door bracket using two 1/4"-20 x 2" carriage bolts and 1/4" nuts (supplied), on center line of door with the middle hole in line with the top rollers.

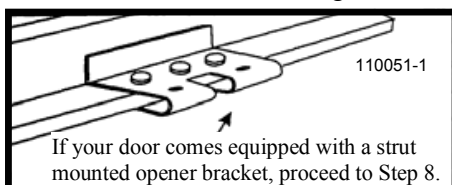

SECTIONAL DOORS AND ONE-PIECE DOORS WITH TRACKS

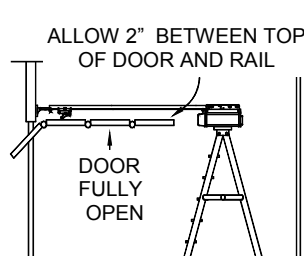

104373

ONE PIECE DOORS WITHOUT TRACKS

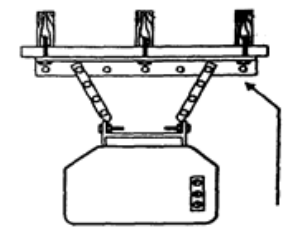
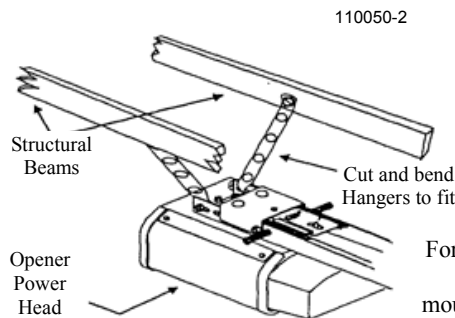
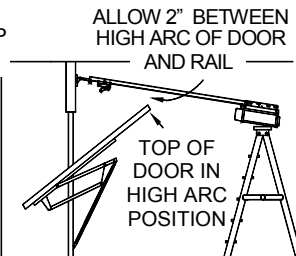

For finished ceilings, or if structural beams are out of position for mounting use a third mounting angle (not included) making sure it is securely mounted to beams.

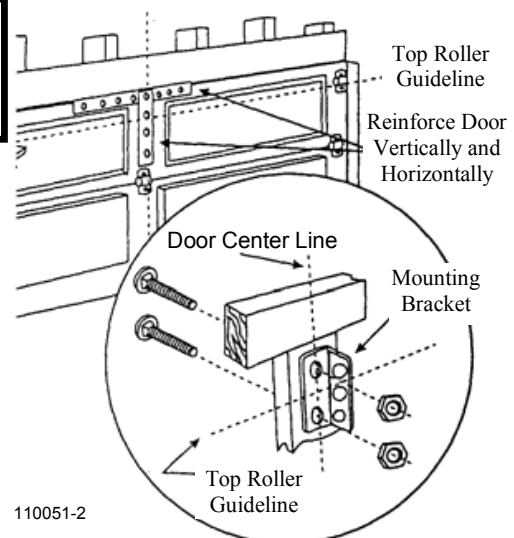

Step 8: Connecting Door Arm to Trolley

(THIS IS FOR SECTIONAL DOORS ONLY - FOR ONE PIECE DOORS PROCEED TO STEP 10)

The door arm assembly consists of the door arm tube section and door arm rod which are packaged separately. To assemble, screw the door arm rod into the the door arm tube in a clockwise direction approximately ten turns. Connect the door arm assembly into the trolley with the open end of the rod hook facing the power head unit (away from the door). Extend the manual release cord (connected to the trolley) and thread through the warning tag and red pull knob handle. Adjust so the knob is 6 feet above the floor and secure with a double overhand knot in the end of the release cord.

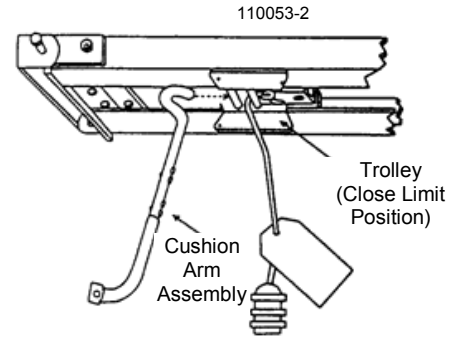

Release the trolley (leave door arm attached) with the manual release cord and pull trolley toward the door.

110054-2

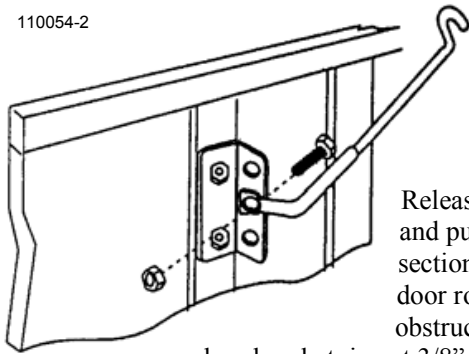

Step 9: Connecting the Door Arm to the Door

Type 1: Door Mounted Bracket

Visually align the door arm connecting hole with the middle hole of the door bracket by rotating the tube section in the appropriate direction.

Release the trolley (leave door arm attached) with the manual release cord and pull trolley toward the power head unit. Now rotate the door arm tube section two turns counterclockwise (increasing the exposed length of the door rod) to provide a cushion when the door is closed or encounters an obstruction. Align connecting hole in the door arm to middle hole in the

door bracket; insert 3/8" diameter bolt and tighten locking nut, allowing for free pivot of the arm. **Note: Do not overtighten locking nut as this will cause binding between the door arm and door bracket.**

Type 2: Strut Mounted Bracket

Visually align the door arm connecting hole with the connecting pin of the strut by rotating the tube section in the appropriate direction.

Release the trolley (leave door arm attached) with the manual release cord and pull trolley toward the power head unit. Now rotate the door arm tube section two turns counterclockwise (increasing the exposed length of the door rod) to provide a cushion when the door is closed or encounters an obstruction. Align connecting hole in the door arm with the strut mounted connecting bracket. Insert connecting pin through the hole in the door arm. Secure the connecting pin to the strut bracket according to the manufacturer's instructions.

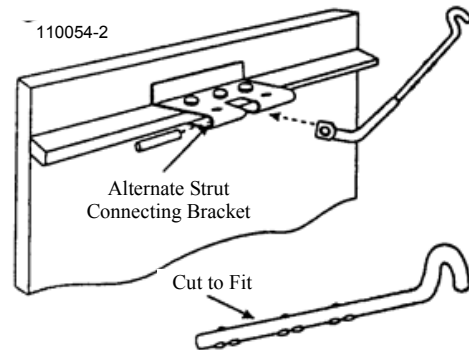

Note: Door Bracket Mount or Strut Mount - If rod bottoms in cushion tube, cut rod to allow for proper function of this assembly.

Step 10: Connecting the Door Arm to the Door - ONE PIECE DOORS (USING OPTIONAL ONE PIECE DOOR ARM ASSEMBLY)

Attach door arm brackets to the top surface of the door on the center line.

Reposition Open and Close limit stops so trolley stops in locations as shown. Assemble the door arm by screwing curved rod into straight tube section. Allow approximately 6" of rod to project outside of the straight tube.

Release trolley with red knob handle and move to a convenient position between Open and Close limits. Connect curved rod section to trolley.

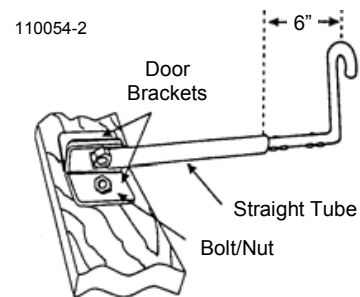

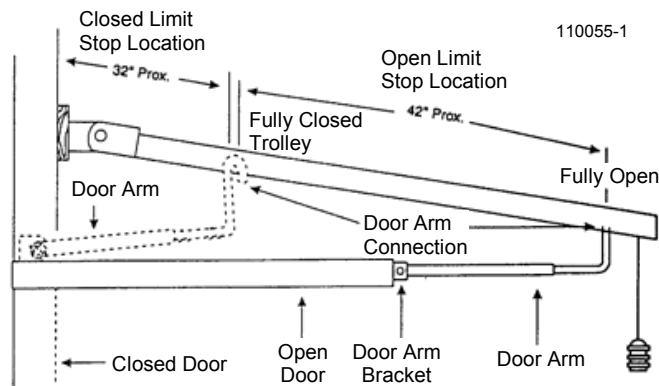

Slide door arm and trolley toward door; connect the tube assembly to the door bracket with the 3/8" diameter bolt and locking nut, tightening enough to allow for door arm pivot. Do not overtighten the locking nut.

Press door control button and run opener through full open and close cycles, adjusting the limit stops as required to fully open and close the door. At full closed position, the door arm assembly should compress approximately one inch.

HOW TO OPERATE THE DOOR MANUALLY - MANUAL RELEASE DISCONNECT

The door should be fully closed, if possible, before using the manual disconnect. Weak or broken springs could allow an open door to fall rapidly. Property damage or serious personal injury could result. Do not use the manual release handle to pull the door open or closed.

Your opener is equipped with a manual release recessed trolley-type disconnect system, enabling manual operation of the garage door during a power failure.

The trolley is disconnected from the chain by pulling down on the red release handle, allowing the garage door to be operated manually.

The trolley will automatically reconnect when power is restored and the door is activated.

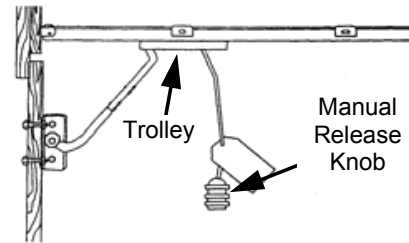

If the manual release is used, close the door before reactivating the opener.

NOTE: Outside keylock manual releases are an available accessory and are recommended for garages without a service entrance.

STEP 11: Connecting The Electrical Power Consult the label on the rear panel of the Opener to determine its proper working voltage. Normally it will be marked for 115V, 60 cycle operation. (If it is an export model designed for 220V, 50 cycle operation, the label will clearly indicate this.) The Opener must be plugged into a properly grounded receptacle within 3 FT of the Power Unit. **A GFI Type receptacle is recommended.** Do not use 2-prong adapters and do not use extension cords for anything more than temporary hook-up and testing purposes. Receptacle wiring should be No. 14 or heavier, and **must be in compliance with local building and electrical codes.**

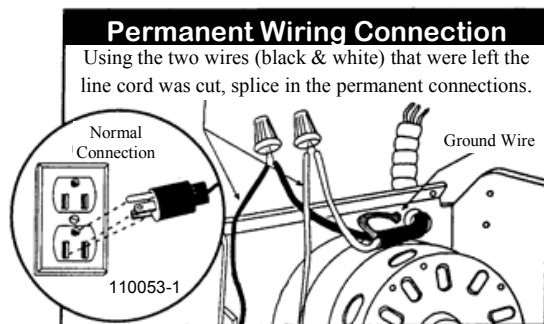

If local codes require permanent wiring, a GFI type circuit breaker is recommended to protect the line. Remove the Strain Relief Bushing and withdraw the Line Cord from the rear of the Power Unit to expose the three insulated connectors. Cut the wire at the rubber jacket of the Line Cord and wire in permanently, employing proper wiring practices. Discard Strain Relief. It is not used with permanent wiring.

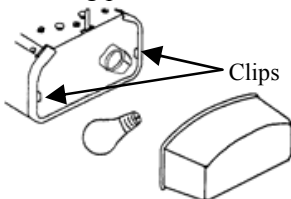

Step 12: Install a **Rough Service** lamp bulb (75 Watt maximum) firmly in the light socket. Light bulbs in door openers are subject to vibration during normal operation which may shorten their life spans. Rough Service bulbs, available at most hardware stores, are recommended. Fit Light Diffuser tabs into the panel tabs as shown.



INSTALLATION OF A STANDARD WALL PUSH BUTTON

A standard wall push button is packaged with your opener. Do not use a door bell button with light. The operating parameters for the standard wall push button are outlined on page 15. The standard wall button is included with your opener.

STEP 1: After determining a suitable location, usually near the access door and at least 5 feet above the floor to prevent use by children, use the standard wall push button as a guide to mark the mounting holes. Drill holes for drywall anchors or screws. NOTE: Do not mount directly to masonry walls. Use backer board.

STEP 2: A length of 2-conductor, #22 gauge wire (or heavier) is required to connect the standard wall push button to the garage door opener. Strip approximately 2" of jacket and 1/2" of insulation from one end of the wire. Carefully connect one wire each to the terminals on the button. Carefully tuck any loose wires into the case and mount the push button using appropriate screws.

STEP 3: Run the wire from the standard wall pushbutton to the operator, supporting it at 18" intervals with suitable staples. Leave a sufficient length to make the necessary connections to the opener terminal strip.



WARNING: SOME LOCAL BUILDING CODES DO NOT ALLOW SURFACE WIRING. BE SAFE AND CHECK WITH YOUR LOCAL BUILDING INSPECTOR FIRST.

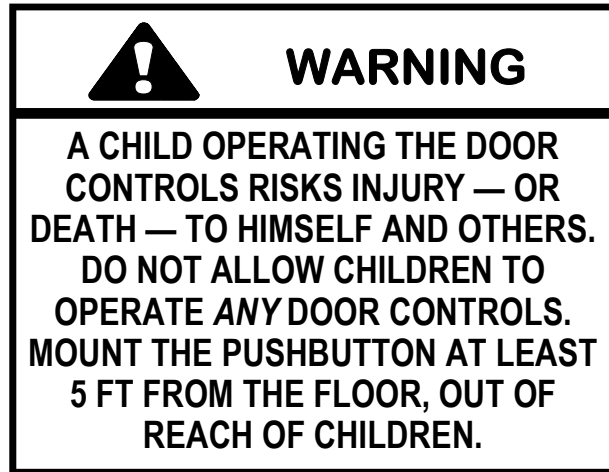

STEP 4: Ensure power is OFF to the opener or disconnect the power from the opener. Strip approximately 4" of jacket from the end of the wire and 1/2" insulation from each wire. Connect to terminals 0 and 1 as shown in the illustration below. Support the wire near the opener with wire ties.

Step 5: Install the Control Button Warning Label supplied with your opener near the standard wall push button (see illustration below).



CONTROL BUTTON WARNING LABEL

Remote Control Radio System

As your transmitter is pre-coded at the factory with three of over 19,000 unique codes. As such, it is possible to control a single operator or a group of operators at one location or at multiple locations. The transmitter may be mounted on a visor using the metal visor clip (included) or attached to a key-chain with the built-in attachment. Your Remote Control Radio System transmitter is compatible with the HomeLink® systems.

Resetting the Transmitter Code

Each button of the transmitter is pre-coded at the factory to one of over 19,000 unique codes. Follow the instructions below to set your own code or to code multiple buttons or transmitters to the same code. You can record your code(s) on the back page of the manual. If recoding is not desired, skip to "Programming the Radio Receiver in the Power Head Unit" on the next page.

The transmitter codes are set using the three operation buttons (+, O, and -) on the front of the transmitter. There are three steps to set the code: **1-** The transmitter is placed in program mode; **2-** the desired button is selected; and **3-** the code is entered. Any one of the buttons or all three buttons may be coded by the sequence outlined below. Also see Express Coding under "Special Notes" at the end of this section.

STEP 1: First, press and hold the "+" button.

The RED LED will turn on. Next, while continuing to hold the "+" button, **press and hold the "-" button.** Continue to hold both the "+" and "-" buttons until

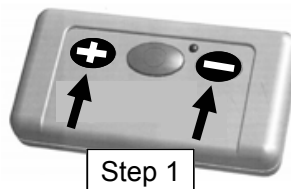

the LED starts to blink (approximately 5 seconds). When the **LED starts to blink IMMEDIATELY release both** the "+" and "-" buttons. The LED will **blink two times** and then remain on to confirm programming mode.

STEP 2: While the LED is on, press and release the button you wish to code. The LED will blink once and then remain on.



STEP 3: Using the operation buttons on the front of the transmitter, enter a 9-digit random code. Every time a button is pressed the LED will turn off and on. After the 9-digit code is entered, the **LED will blink twice to confirm** a valid code and remain off.

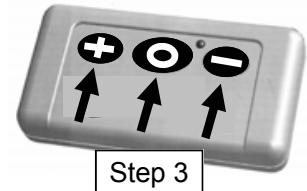

SPECIAL NOTE - EXPRESS CODING

- Allows you to code all three buttons with a single coding process, follow Steps 1, 2, & 3 (previous) except:
- Select the "+" button in Step 2
- End the entered code in Step 3 with the ninth (last) position as a "+" button entry

ALL THREE TRANSMITTER BUTTONS ARE NOW CODED.

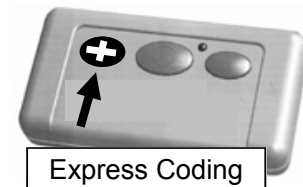

WARNING

TO PREVENT THE RISK OF PERSONAL INJURY, DAMAGE TO DOOR OR PROPERTY, ONLY OPERATE DOOR CONTROLS WHEN DOOR IS IN CLEAR VIEW. KEEP REMOTE CONTROL AWAY FROM CHILDREN IN A SECURE AREA.

FOR MULTIPLE OPERATOR INSTALLATIONS

First code all transmitters using **EXPRESS CODING** (see above for directions) Then use a single transmitter to teach the operators the transmitter code

 **HomeLink**
HomeLink® is a registered trade mark of Johnson Controls, Inc.

This device complies with Part 15 of the FCC Rules and with RSS-210 of Industry Canada. Operation is subject to the following two conditions: (1) This device may not cause harmful interference, and (2) this device must accept any interference received, including interference that may cause undesired operation.





TEACHING THE OPERATOR THE TRANSMITTER CODE

Press Learn Enable button on the opener back panel
 Red LED and work light on the operator will turn ON
 (Note: Your radio system will learn **8 different** transmitter codes. If red LED stays on and the work light blinks press and hold Program Button for 5 seconds to clear memory and start over)

Transmit desired pushbutton - red LED AND work light will turn off (ensure work light AND LED turn off - If LED remains on when you transmit a code press and hold Program Button for 5 seconds to clear memory and start over)

Opener has been programmed - next transmission will operate the door.

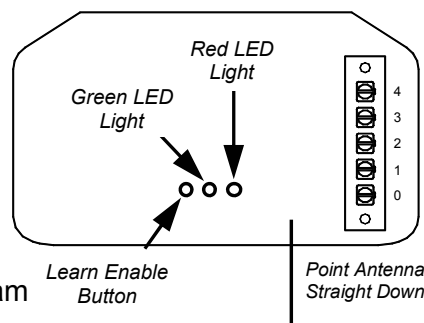

FOR MULTIPLE OPERATOR INSTALLATIONS

First code all transmitters using **EXPRESS CODING** (see page previous for directions). Then use a single transmitter to teach the operators the transmitter code



WARNING

TO PREVENT THE RISK OF PERSONAL INJURY, DAMAGE TO DOOR OR PROPERTY, ONLY OPERATE DOOR CONTROLS WHEN DOOR IS IN CLEAR VIEW. KEEP REMOTE CONTROL AWAY FROM CHILDREN IN A SECURE AREA.

Recheck the antenna wire on the power head unit, for proper operation the antenna wire should be **POINTED STRAIGHT DOWN** toward the floor for most situations.

Installing the Transmitter

The transmitter is supplied with a metal clip which may be used to attach the unit to a sun visor. If the clip is used, slide it into the recess provided on the back of the transmitter case until the snaps on the case fit around the clip. If the transmitter is installed in a pocket in your car, follow all the manufacturer's instructions. Improper installation may cause intermittent transmitter operation which can result in unexpected door operations.



Battery Replacement

Your Quik-Code transmitter is provided with two factory installed 3-volt batteries which should be replaced after two years of normal use. The transmitter code is retained in permanent memory and will not be lost during battery replacement. To replace the batteries, remove the back of the case using a quarter or your thumb. Carefully slip the batteries out of the holders and replace with fresh CR2032 3-volt batteries. The "+" on the batteries must point away from the circuit board. Replace the back of the cover and resume normal use.

Radio Operational Check -

After programming your transmitter and the receiver power head unit, check the operation of your radio controls by moving approximately 45 feet back from the garage door, then press the appropriate transmitter button that has been programmed for that door. The red LED light will illuminate on the front face of the transmitter. This is your indication that a signal has been generated and sent out by the transmitter (provided a valid programming sequence has been done with the transmitter). Operation at this distance should be reliable. However, environmental conditions and the location of the transmitter and receiver antenna will affect distance.

- If the opener doesn't activate check if the power head unit has been programmed to accept the transmitter signal. The red LED on the rear panel of the power head unit will blink two times rapidly if it has accepted a valid transmitter signal. If the LED light does not blink reprogram the power head unit to accept the transmitter signal by following the instructions above making sure you erase any previously learned signal (see above).
- If the distance is inadequate check the transmitter battery and replace if necessary and/or check the position of the power head unit antenna (see above).
- To maximize the operating distance move the transmitter to different locations in the car until a satisfactory distance is achieved. Vanity mirrors on sun visors will affect performance.



INSTALLATION OF THE SAFE FINISH PHOTOSYSTEM

STEP 1: Mark the position of the SAFE FINISH™ Photosystem as follows: Mark a line on the left and right door jamb (close to the door track)

FOUR (4) inches AND SIX (6) inches above the floor. *The top mark is the maximum height and the bottom line is the minimum height that the photosystem accessory can be placed.*

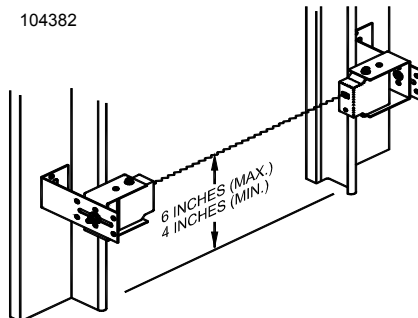

STEP 2: Mount the Photosystem "L" Brackets as follows:

A. Remove the four mounting brackets from the package. Temporarily place the "U" shaped brackets, one around the receiver (unit with window and red LED) and one around the transmitter. **NOTE:** *It is easier to slip the photosystem units in from the side of the bracket than forcing them in from the front of the bracket.*

B. Your photosystem assembly is provided with a universal bracket set. Using either the transmitter or receiver (window up towards the ceiling), hold the "L" bracket and the "U" bracket set together while moving them in between the limit marks on the door jamb. Continue to move the photosystem assembly within the limit marks until it clears the door hardware. *See Illustration, above.* **Check to ensure the window on the front of the photosystem is within the limit marks on the door jamb.**

C. Place a mark in the center of the lag screw elongated mounting hole. Measure its position and place a similar mark on the opposite door jamb. The brackets may be temporarily mounted to the jamb with a 1" flat head nail (provided) using the small hole above the slot. Using two 5/16" X 1-1/2" lag screws (provided), permanently mount the "L" bracket to both door jambs.

STEP 3: Connect the Photosystem as follows:

Refer to wiring diagrams on page 14 & 19 for the Safe Finish™ Photosystem connection illustration.

A. Remove the transmitter and receiver from their "U" mounting brackets.

Run a wire pair (not supplied) around the garage door jamb between the transmitter and receiver "L" mounting brackets. **NOTE:** Leave about 12" of extra wire at each end. Use a minimum 22 gauge solid

"trace" wire for interconnect.

B. Run a wire pair (20 or 22 gage solid wire) from the receiver position (unit with "LED" light in the front, may be either side of the door) back to the rear bulkhead of the garage door opener. **NOTE:** Leave about 12" of extra wire at the receiver end and about 24" of extra wire at the opener end.

C. Strip approximately 5/16" from each wire end at the photosystem units and at the opener.

D. Using two (2) wire nuts (supplied), connect the wire ends at the SAFE FINISH™ Photosystem transmitter to the pigtail wire ends coming out of the transmitter unit. *Although not required, it is recommended to connect the trace wire ends together and the unmarked wire ends together.*

E. Using two (2) wire nuts (supplied), connect the wire ends at the SAFE FINISH™ Photosystem receiver to the pigtail wire ends coming out of the receiver unit. *Although not required, it is recommended to connect the trace wire ends together and the unmarked wire ends together.*

STEP 4 : Final Installation

A. Attach the "U" brackets to the "L" brackets with a 1/4-20 carriage bolt, washer and hex nut (provided). Insert the bolt from the inside of the "U" bracket and hand tighten only at this time.

B. Place the transmitter and receiver units into their respective "U" brackets. *See Illustration, below.*

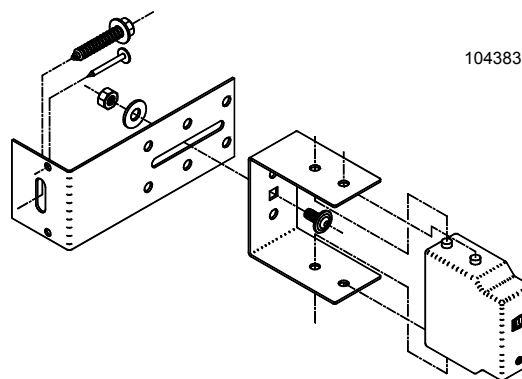
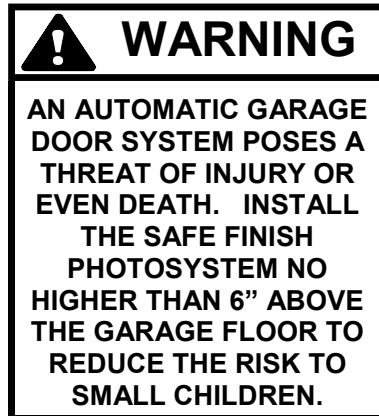



C. Connect the interconnect wire pair to the garage door opener terminals marked "1" & "4". Although not required, it is suggested that the "trace" be connected to Terminal 4. See wiring diagrams, below and page 19.

Tighten all mounting screws and bolts. Final alignment and the system test is covered on Page 18, "Operation and Adjustment Instructions".

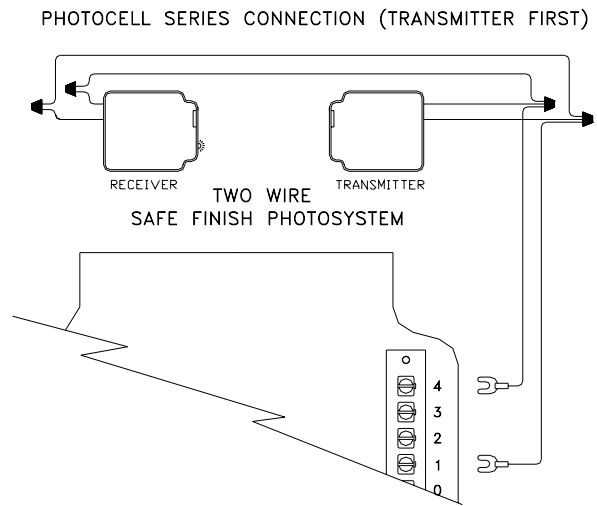
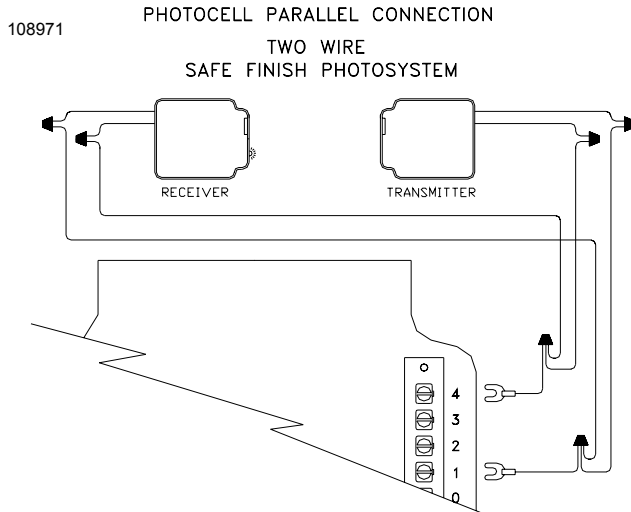

PRE-POWER ON- INSTALLATION CHECKLIST

Before continuing with the operation and adjustment section, make sure that:

1. The front and rear mounts for the opener are sound and secure and the rail is positioned correctly above the high arc of the door, and that the opener is positioned over the door action centerline.

2. For sectional door and one piece door with tracks, the position of the door arm (with the door closed), is such that it's connecting point on the trolley is 5" to 8" behind it's connecting point on the door bracket. The door arm should never be perfectly vertical when the door is in the closed position.

For one piece doors without tracks, the position of the door arm (with the door closed) is such that it's connecting point on the trolley is approximately 30" behind it's connecting point on the door bracket. The straight portion of the door arm should be at an angle of 15-20° with respect to the floor the door is closed.

3. The Manual Release Label and cord are secure to the Manual Release Lever. The handle is located 6 FT above floor level and requires no more than a 50 pound pull to activate. The trolley and the release mechanism are properly lubricated.
4. All push button controls are mounted at such a position and of such height that they can only be

actuated by an adult of average height. The Control Button Warning label is prominently displayed next to the push button or Super Station.

5. All wiring is correct to codes or better. There is ground continuity from the supply. The ground prong on the power cord is intact.
6. All ropes have been removed from the door. The door moves freely without binding when raised or lowered manually. The door is correctly balanced and lubricated. All door hardware is secure and sound. The sensitivity has been adjusted to minimum force for the application.
7. The concrete or other surface beneath the closed door provided uniform contact.
8. The plastic envelope for this manual is attached to the wall near the push button or wall station and this manual is placed there for owner use and reference.
9. On door with extension type counterbalance springs, restraint cables have been placed through the springs.
10. There is Ground Fault Interruption (GFI) protection of the power line to the opener or in the receptacle.
11. On doors with adjustable bottom edges, edges have been locked after adjustment.

15 — E: OPERATION AND ADJUSTMENT INSTRUCTIONS

IMPORTANT SAFETY INSTRUCTIONS

 **WARNING!** **TO REDUCE THE RISK OF SEVERE INJURY OR DEATH**
READ AND FOLLOW ALL INSTRUCTIONS!

- NEVER LET CHILDREN OPERATE OR PLAY WITH DOOR CONTROLS. KEEP THE REMOTE CONTROL AWAY FROM CHILDREN.
- ALWAYS KEEP A MOVING DOOR IN SIGHT AND KEEP PEOPLE AND OBJECTS AWAY FROM THE DOOR AREA UNTIL THE DOOR IS COMPLETELY CLOSED. NO ONE SHOULD CROSS THE PATH OF A MOVING DOOR.
- NEVER GO UNDER A STOPPED, PARTIALLY OPEN DOOR.
- TEST THE DOOR OPENER MONTHLY. THE DOOR MUST REVERSE UPON CONTACT WITH A 1-1/2" HIGH OBJECT (OR A 2 X 4 BOARD LAID FLAT) ON THE FLOOR. AFTER ADJUSTING THE SENSITIVITY OR THE LIMIT OF TRAVEL, ALWAYS RETEST THE OPENER. FAILURE TO ADJUST THE OPENER PROPERLY MAY RESULT IN SERIOUS INJURY OR DEATH.
- IF POSSIBLE, USE THE EMERGENCY RELEASE ONLY WHEN THE DOOR IS CLOSED. USE CAUTION WHEN USING THE RELEASE WITH THE DOOR OPEN. WEAK OR BROKEN SPRINGS MAY ALLOW THE DOOR TO CLOSE RAPIDLY, CAUSING SEVERE INJURY OR DEATH.
- KEEP THE GARAGE DOOR PROPERLY BALANCED. SEE THE DOOR OWNER'S MANUAL. AN IMPROPERLY BALANCED DOOR MAY CAUSE SEVERE INJURY OR DEATH. HAVE A QUALIFIED SERVICE PERSON MAKE REPAIRS TO CABLES, SPRING ASSEMBLIES AND OTHER HARDWARE.
- SAVE THESE INSTRUCTIONS!

TURNING ON POWER TO THE OPENER

NOTE: It is now necessary to turn on the power in order to run the opener to test the operation and check the limit settings. Before doing so, ensure that all the items on the pre-power on checklist (page 14) have been verified and that the doorway is clear.

BASIC OPERATING PARAMETERS

Please note the following Operating Parameters which apply to openers with Auxiliary Entrapment Protection System (Safe Finish™ Photosystem, Installation Instructions on Page 13) and a standard wall push button connected.

IF THE DOOR IS...

...**FULLY OPEN**, then pushing the standard wall Push Button or the radio control will cause the door to begin **MOVING DOWNWARD**.

...**FULLY CLOSED**, then pushing the wall Push Button or the radio control will cause the door to begin **MOVING UPWARD**.

...**MOVING UPWARD**, then pushing the wall Push Button will cause the door to **STOP**. The next push of the wall button will cause the door to begin **MOVING DOWNWARD (Alternate Action Operation)**.

...**MOVING UPWARD**, then pushing the radio control will cause the door to **STOP**. The next push of the wall button will cause the door to **RESUME UPWARD MOVEMENT (Radio Operation)**.

...**MOVING DOWNWARD**, then pushing the wall Push Button or the radio control will cause the door to **STOP, PAUSE FOR APPROXIMATELY ONE SECOND, AND THEN BEGIN MOVING UPWARD**.

...**MOVING DOWNWARD** then reaches the down limit, the lamp will blink off for a 1/2 second then turn back on again, remaining on for 4 minutes 30 seconds and will then automatically turn off.

...**MOVING UPWARD** then reaches the open limit, the lamp will remain on for 4 minutes 30 seconds and will then automatically turn off.



Adjustment #1: Opening Travel

Your opener is assembled at the factory with the trolley in the forward position with the open limit stops snapped in place on the chain, set for a standard door.

If your door is non-standard, move BOTH open limit stops, located just behind the trolley. As an example: For a 6 FT, 6 INCH door, move both open limit stops six inches or 12 links toward the power head unit.

To confirm final opening travel adjustment, activate the opener to bring the door to the fully open position. When properly adjusted, center of the open limit stops should come to rest opposite the load adjusting nut.

NOTE: If the door drifts forward, move the open limit stops toward the power head unit. If the door does not drift forward it is still advised that you perform one additional check. Operate manual release on the trolley and allow the door to seek its natural fully open position, then move the open limit stops to align trolley to this position. If the door does not open fully at its natural open position, it indicates a door spring or hardware problem that should be referred to a door system professional.

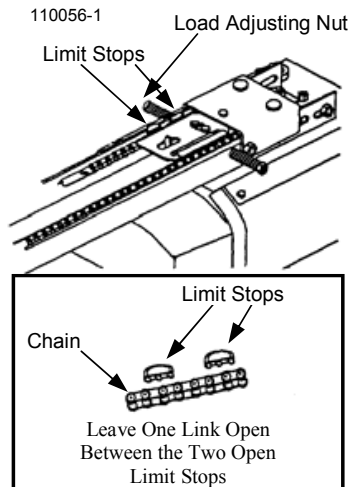

Adjustment #2: Opening and Closing Force

Hex nuts for adjusting force are located on either side of the rail at the motor end. The left hex nut, labeled "CLOSE", adjusts the closing force; the right hex nut, labeled "OPEN", adjusts the opening force.

Turning the hex nuts clockwise increases force; counterclockwise decreases force.

Your garage door opener is built with a safety system that allows the door to reverse in the close direction and stop in the open direction. This must be adjusted so your opener does not use excessive force in the down direction or react to the weight of the door during upward travel.

To help determine that the force is not excessive, grasp the door handle or bottom edge during downward travel. The opener should reverse to this force. Do not stand under the door during this test.

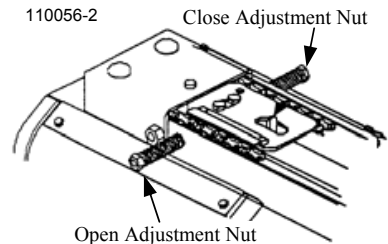

If the handle is hard to hold and the door does not reverse, adjust the CLOSE hex nut to decrease force until the door reacts properly.

Repeat the adjustment procedure for upward travel. The door should stop without using excessive force.



WARNING

IF LIMITS ARE NOT ADJUSTED PROPERLY, THE EMERGENCY RELEASE MECHANISM MAY NOT WORK PROPERLY AND DOOR OPERATION COULD RESULT IN DOOR DAMAGE, SERIOUS PERSONAL INJURY OR DEATH!

Adjustment #3: Setting Door Close Limit

Confirm trolley close position 9" to 10" between the inside face of the door and the point where the door arm connects to the trolley (see illustration) for a sectional door (one piece door is approximately 32").

If adjustment of the close trolley position is necessary, activate the opener and move the trolley 12" to 18" to provide access to the "Limit Stop" devices (mounted on the chain). Move the limit stop to establish the correct trolley close position as above.

Relocation of "Limit Stop" toward the door increases down travel. Relocation of the limit stop away from the door reduces down travel. Note that each chain link provides 1/2" adjustment of trolley travel.

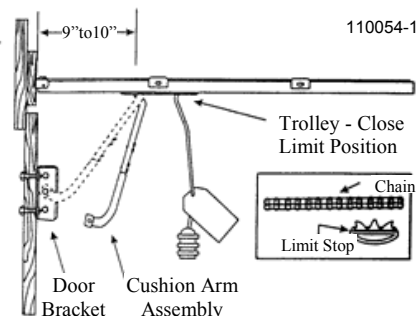

17 — E: OPERATION AND ADJUSTMENT INSTRUCTIONS

Adjustment #4: Obstruction Sensing (Closing Direction)

Your opener is designed to automatically reverse the door during closing travel whenever it comes into contact with an object up to the last 1-1/2 inch of travel above the floor. An object on the floor with a height of less than 1-1/2 inch will cause the door to stop. (Test according to the instructions below.)

If the opener reverses properly with a 2 x 4 board laid flat on the garage floor (as the test below) and stops in the fully closed position, proceed to Adjustment #6.

If the door reverses when it comes into contact with the floor, move the close limit stop, located on the left side (inside looking out, see figure Adjustment #1), towards the power head unit. It is advised that you move the close limit stop one link at a time and run opener through another close cycle, until the door stops when it comes into contact with the floor.

If the door comes into contact with a 2 x 4 board laid flat on the garage floor and stops instead of reversing, move the close limit stop away from the power head unit. It is advised that you move the close limit stop one link at a time and run opener through another close cycle, until the door reverses when it comes into contact with the 2 x 4 board.

Important Test: Opener Obstruction Sensing Feature for Doors (both Sectional and One Piece)

- A. Activate door to the Open position.
- B. Place 2 x 4 board laid flat on garage floor under path of the door. See Figure at right.

C. Activate door to close position; upon contacting solid object, the door should stop, then reverse direction within 2 seconds and travel to the full open position.

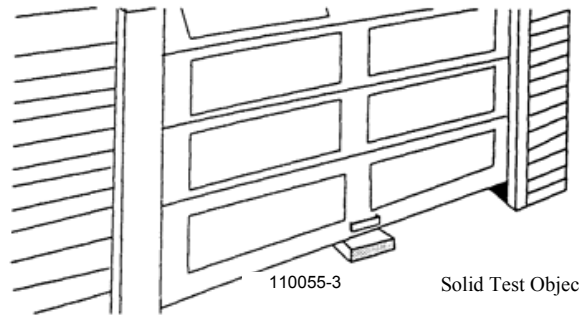

 **WARNING**

IMPROPER ADJUSTMENT OF SENSITIVITY SYSTEM FORCE COULD CAUSE ENTRAPMENT, INJURY OR DEATH. SET ADJUSTMENTS FOR JUST ENOUGH FORCE TO OPERATE THE DOOR RELIABLY, BUT NO STRONGER. Contact a service professional to correct any binding, sticking or other door problems. DO NOT OVER-ADJUST SENSITIVITY SYSTEM TO COMPENSATE FOR A POORLY WORKING DOOR.

Note: If the fails to pass this test, see Adjustment 3 and move the Close Limit Stop one increment towards the door to increase down travel. Also review Steps 8 and 9, Page 8 for Sectional Doors or Step 10, Page 8 for One Piece Doors.

REPEAT THIS TEST MONTHLY!

 **WARNING**

THE SENSITIVITY SYSTEM REVERSING TEST SHOULD BE PERFORMED MONTHLY TO ENSURE THAT THIS IMPORTANT SYSTEM REMAINS IN PROPER ADJUSTMENT.



Adjustment #5: Positive Mechanical Lock Adjustment

The garage door opener is designed with an automatic mechanical locking system. This lock secures the door in the fully closed position.

To adjust, activate your opener and allow the door to go to its fully closed position. Loosen the two screws on

the rail stop and move it behind the chain latch assembly with a gap of 1/2" between "stop" and "latch".

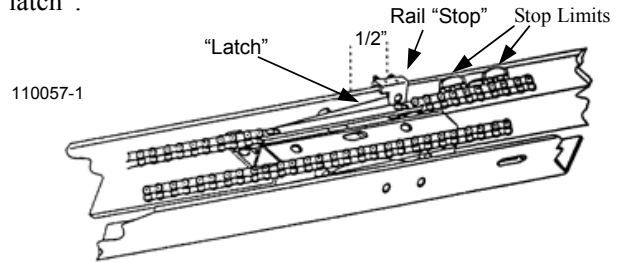

Adjustment #6: Alignment and Initial Test of Safe Finish Photosystem

- A. Keep a portable transmitter with you to control the garage door opener. The red light on the receiver unit should now be on. *If not, recheck that the mounting screws are tight then, if necessary, align the photosystem by slightly bending the wall bracket until proper operation is obtained.*
- B. Place an object (packing insert box or a similar object approximately six inches high) one foot in front of the transmitter or receiver. The red LED should go OFF and remain OFF until the object is removed. **NOTE:** *There may be a slight delay in returning to normal depending upon how long*

the photosystem was blocked. If the light fails to go off when the object is placed in the path of the beam check the wire connections and the installation height of the units (see Page 13).

- C. **Move to the center of the door. Make sure the red LED light is on. Move a solid object slowly through the beam. The LED should go OFF and then ON.**
- D. Using the pushbutton or transmitter, activate the opener and check that it will operate through the full open and close cycles. *If not, re-align the photosystem by slightly bending the wall bracket until proper operation is obtained.*
- E. Tighten all mounting screws and bolts, loop and secure any extra wire.

Important Test: Photoelectric Obstruction Test

Test Procedure

Place an object 6" x 12" on the floor (as illustrated) progressively on foot from the left side of the door; center of the door and one foot from the right side of the door. The object must prevent an open door from closing in any other mode other than constant pressure on the wall button. The object should also cause a closing door stop and reverse to the open position. If it doesn't, the Safe Finish photoelectric system must be adjusted lower and the test repeated until the door responds properly to the 6" object.

If adjustments are needed, refer to preceding adjustment.

If the unit still will not respond and fails this obstruction sensing beam test, the door may cause severe injury or death. Have a qualified service person make repairs.

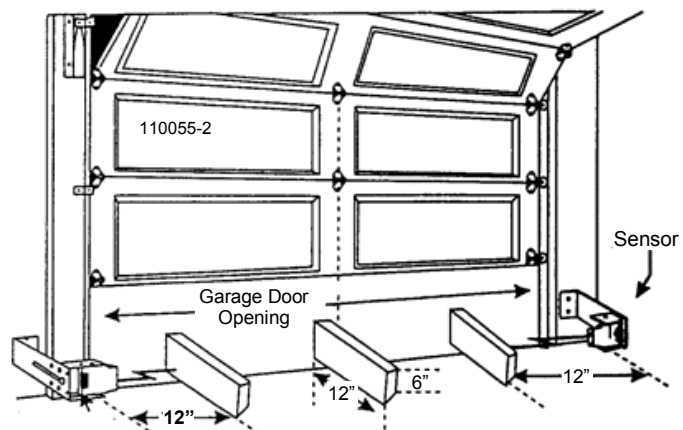

19 — E: OPERATION AND ADJUSTMENT INSTRUCTIONS

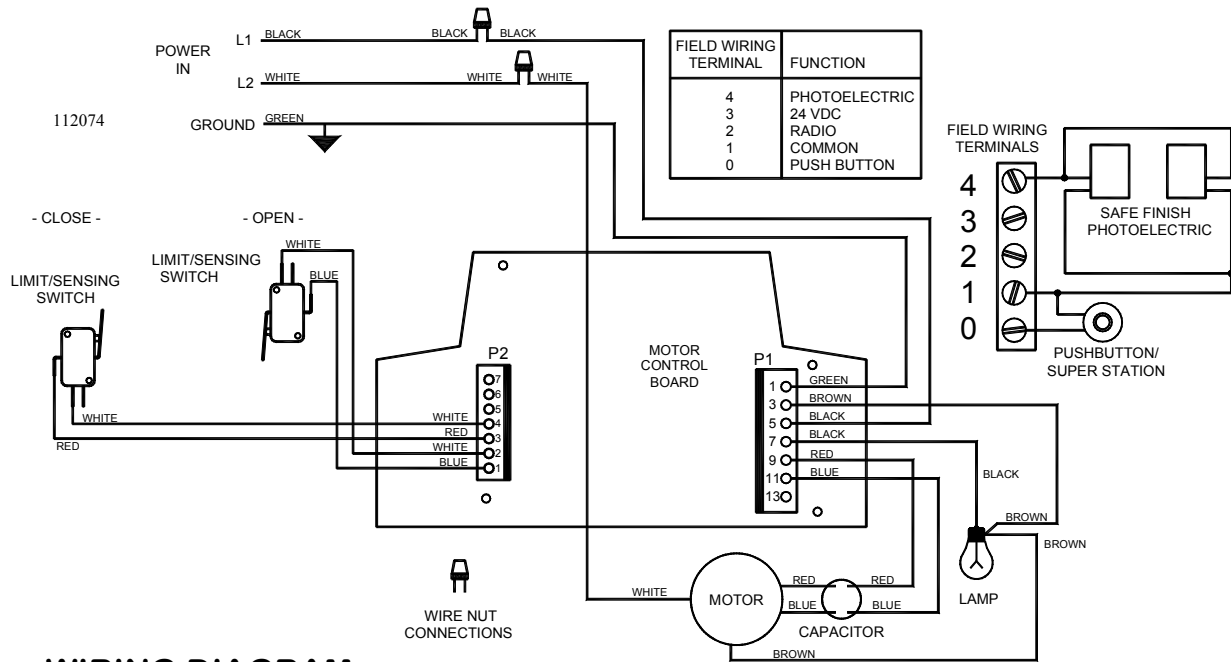

WIRING DIAGRAM

TROUBLESHOOTING GUIDE

USE EXTREME CAUTION AT ALL TIMES WHEN ATTEMPTING TO DIAGNOSE AND RECTIFY PROBLEMS WITH YOUR GARAGE DOOR OPENER. BEFORE ATTEMPTING ANY SERVICE ON UNIT, DISCONNECT OPENER FROM POWER SUPPLY. YOUR GARAGE DOOR IS THE LARGEST MOVING OBJECT IN YOUR HOUSE, AND THE SPRINGS, PULLEYS, CABLES AND MOUNTING HARDWARE UTILIZED TO BALANCE ITS OPERATION ARE UNDER EXTREME TENSION AT ALL TIMES AND CAN CAUSE SERIOUS PERSONAL INJURY, EVEN DEATH, IF DISTURBED. CALL AN EXPERIENCED SERVICE PERSON TO MOVE, LOOSEN OR ADJUST DOOR SPRINGS OR HARDWARE.

With the appropriate cautions in place, use the fast find LED diagnostic chart at right to diagnose the problem. The LEDs are located on the power head unit rear panel, see page 12 for illustration. Contact the factory if your problem persists or is not listed.

DIAGNOSTIC CONDITION	RED LED	GREEN LED
Normal Operation	OFF	OFF
Learn Mode	ON	OFF
Memory Full	ON FOR 25 SEC, AUTO OFF	OFF
Decode RF Signal	SHORT FAST BLINK	OFF
Shorted Push Button or Wire to Button	OFF	ON
Photobeam Obstruction	OFF	FAST BLINK
Contact Reverse	FAST BLINK	OFF
Stuck Relay	SLOW BLINK	OFF
Stuck Open Limit	OFF	SLOW BLINK

NOTES



Manufacturer's Limited Warranty

Allstar warrants its 9000M Series Challenger residential vehicular garage door openers as follows:

- A. The drive train to be free from defects in materials and workmanship for:
 Models 9300M/9500M/J9500M: for 10 years from the date of purchase by the original purchaser.
 The drive train includes the motor, rails, frame and chain.
- B. The controller circuit board, capacitor, photobeams and all other parts in all models will be free from defects in materials and workmanship for a period of two (2) years from the date of purchase by the original purchaser.

Contact your dealer to obtain service for your opener .

To obtain service under this warranty the buyer must obtain authorization instructions for the return of any goods from Allstar before returning the goods. The goods must be returned with complete identification, with copy of proof-of-purchase, freight prepaid and in accordance with Allstar's instructions or they will not be accepted. In no event will Allstar be responsible for goods returned without proper authorization or identification.

Goods returned to Allstar for warranty repair within the warranty period, which upon receipt by Allstar are confirmed to be defective and covered by this limited warranty, will be repaired or replaced at Allstar's sole option, at no cost and returned pre-paid. Defective parts will be repaired or replaced with new or factory rebuilt parts at Allstar's sole option.

This limited warranty does not cover non-defect damage, damage caused by unreasonable use, damage caused by improper installation or care, vandalism or lightning, fire or excessive heat, flood or other acts of God (including, but not limited to misuse, abuse or alterations, failure to provide reasonable and necessary maintenance), labor charges for dismantling or reinstalling a repaired or replaced unit, or replacement batteries.

These warranties are in lieu of all other warranties, either expressed or implied. All implied warranties of merchantability and/or fitness for a particular purpose are hereby disclaimed and excluded. Under no circumstances shall Allstar be liable for consequential, incidental or special damages arising in connection with the use or inability to use this product. In no event shall Allstar's liability for breach of warranty, breach of contract, negligence or strict liability exceed the cost of the product covered hereby. No person is authorized to assume for Allstar any other liability in connection with the sale of this product.

This warranty gives you specific legal rights. You may also have other rights which vary from state to state. Warranty effective after May 1, 2004.

Serial #:
Date Installed:
Your Dealer:

**c.p. Allstar Corporation
Downingtown, PA 19335**

**This garage door opener is built in the USA
and complies with all requirements of
Underwriters Laboratories Standard UL-325.
P/N 112075 Rev. B March 2006**

Your Radio System can learn **8 different** transmitter codes. See Page 14 and, if desired, record your code settings below.

Code Position ⇒	1	2	3	4	5	6	7	8	9
Plus (+) Button									
Zero (0) Button									
Minus (-) Button									

See Page 14 for Radio System programming instructions and FCC/RSS-210 Industry Canada statement. Allstar opener radio systems are HomeLink® compatible.