

INSTALLER: Place this manual in the plastic envelope provided and permanently attach to the wall near the pushbutton.

INSTALLATION AND OWNER'S MANUAL 6000 SERIES

Residential Vehicular Garage Door Operator
MODELS: 6000, 6500, 6500-P & J6500

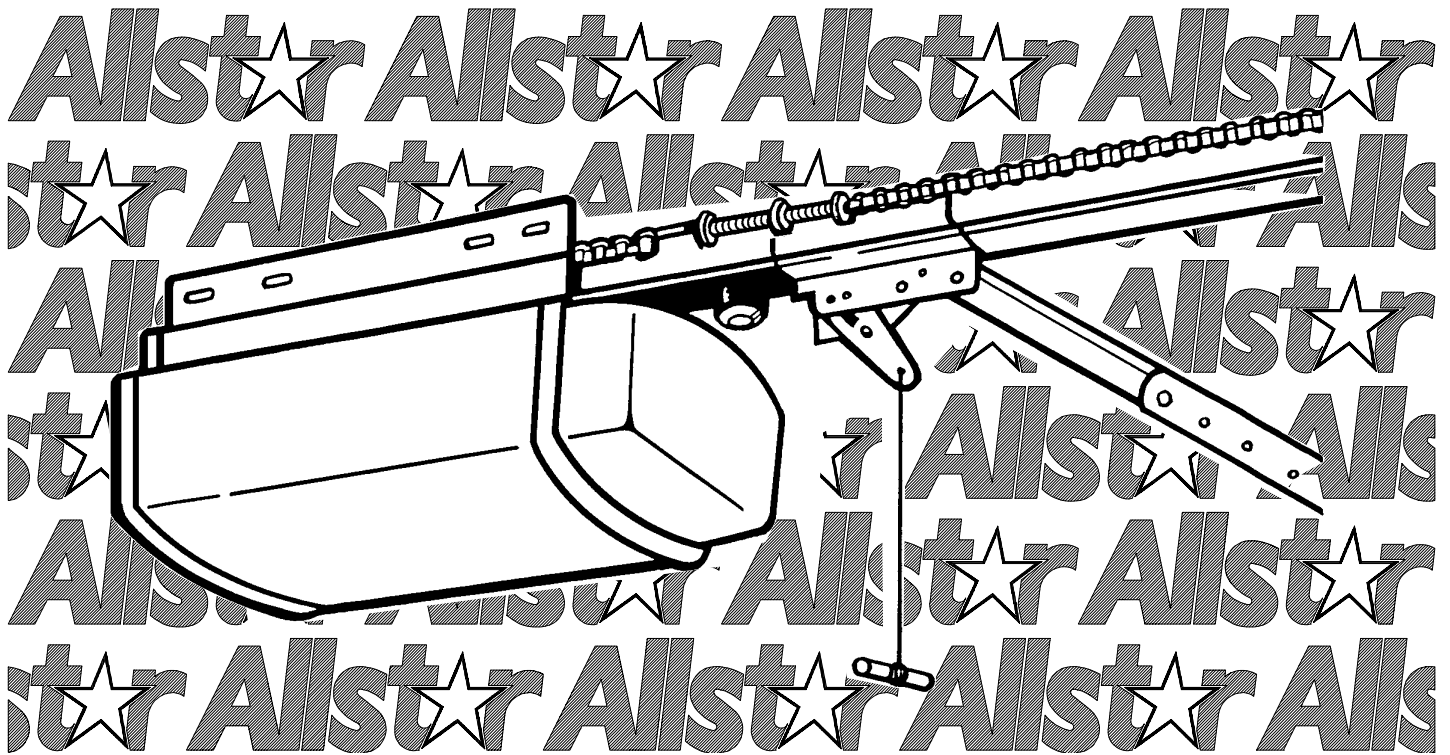

107063



As of date of manufacture,
meets all ANSI/UL 325
Safety Requirements for
Vehicular Garage Door
Operators

Serial #:
Date Installed:
Your Dealer:

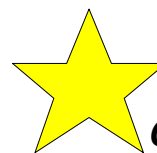

**READ THIS MANUAL
CAREFULLY BEFORE
INSTALLATION OR USE**

★ TABLE OF CONTENTS

Product Features	2
Component Identification/Tools Required	4
Section A: Assembly Instructions	5
Section B: Installation Notes.....	6
Section C: Installing the Operator	7
Identify Your Door Type	7
Mounting the Front Bracket.....	8
Mounting the Power Head.....	9
Door Arm Installation	10
Pushbutton Connection.....	11
Section D: Auxiliary Equipment.....	13
Installation of All-Clear	13
Installation of Radio Controls.....	14
Installation of the Super Station.....	15
Operating Parameters.....	16
Section F: Operation and Adjustment Instructions	17
Safety Notes	17
Testing the Sensitivity	18
Testing the Reversing System	18
Testing the All-Clear.....	19
Operating the Super Station	19
Operator Wiring Diagram	20
Auxiliary Equipment Wiring Diagram	21
Installation Checklist.....	22
Troubleshooting Guide.....	23

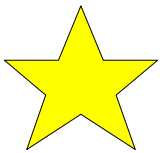

READ THESE STATEMENTS CAREFULLY AND FOLLOW THE INSTRUCTIONS CLOSELY.

The Warning and Caution boxes throughout this manual are there to protect you and your equipment. Pay close attention to these boxes as you follow the manual.

WARNING
Indicates a MECHANICAL hazard of INJURY OR DEATH. Gives instructions to avoid the hazard.

CAUTION
Indicates a MECHANICAL hazard of DAMAGE to your gate, gate operator, or equipment. Gives instructions to avoid the hazard.

WARNING
Indicates an ELECTRICAL hazard of INJURY OR DEATH. Gives instructions to avoid the hazard.

CAUTION
Indicates an ELECTRICAL hazard of DAMAGE to your gate, gate operator, or equipment. Gives instructions to avoid the hazard.



The purpose of this booklet is to provide assembly, installation and operation information concerning the 6000 Series Residential Garage Door Openers and related Accessory Products.

NOTICE

IT IS IMPORTANT THAT THIS INSTRUCTION MANUAL BE READ AND UNDERSTOOD COMPLETELY BEFORE INSTALLATION OR OPERATION IS ATTEMPTED.

NOTICE

THE IMPORTANT SAFEGUARDS AND INSTRUCTIONS IN THIS MANUAL CANNOT COVER ALL POSSIBLE CONDITIONS AND SITUATIONS WHICH MAY OCCUR DURING ITS USE. IT MUST BE UNDERSTOOD THAT COMMON SENSE AND CAUTION MUST BE EXERCISED BY THE PERSON(S) INSTALLING, MAINTAINING AND OPERATING THE EQUIPMENT DESCRIBED HEREIN. DO NOT USE THIS EQUIPMENT FOR ANY OTHER THAN ITS INTENDED PURPOSE - OPERATING OVERHEAD GARAGE DOORS.

STANDARD FEATURES:

Sensing System: A built-in sensing system detects obstructions during door operation. If in the downward (close) travel mode, the Opener will sense an obstruction and reverse the direction of the door. In the open mode, the Opener will stop. Since all doors are different, the Sensing System has independent adjustments for customizing the level of force required for the normal opening and closing of specified doors. (Page 18)

Close Limit Switch: In winter months it's common for small pieces of ice or packed snow to be trapped under the door. Ground swelling can also effect the close limit setting of the Opener. The 6000 Series Close Limit Switch overrides the Sensing System during the last one inch of closing travel and prevents the door from reversing if it encounters an obstruction at this point.

Alternating Action Operation: The mechanical wall pushbutton functions in an Open/Stop/Close/Stop & Reverse mode in normal operation. (Page 16)

Emergency Release: A pull cord allows separation of the drive mechanism and manual operation of the door when desired, as in the event of a power failure. (Page 11)

Automatic Reconnection: Once power is restored, or automatic operation of the door is again desired, initiating operation in the normal manner (Push Button, Radio Control, etc.) will effect automatic reconnection of the Emergency Release Mechanism. (Page 11)

Connections For Continuously Monitored Auxiliary

Entrapment Protection Devices: The 6000 Series All-Clear™ Photosystem (light beam across the door opening) can be easily connected to the Opener. Control circuitry monitors the device continuously for proper operation. (Page 20) Consult the factory for compatibility of other auxiliary entrapment protection devices.

Constant Contact To Close: For utmost safety, the standard operation mode requires constant contact on the mechanical Push Button to close the door if an Auxiliary Entrapment Protection Device (see above) IS NOT installed or if the Device fails. In this mode of operation, a Radio Transmitter cannot be used to close the door. (Page 13 & 14)

Momentary Contact To Close: After installing an All-Clear™ Photosystem Auxiliary Entrapment Protection Device the close operation mode is automatically converted to momentary contact of the mechanical Push Button, and a portable Radio Transmitter can be used to close the door. (Page 16)

All-Clear™ Photosystem: An invisible infrared beam of light guards the door opening and reverses a downward moving door if the beam is broken by a stationary or moving object. The 6000 Series motor control circuitry constantly monitors the All-Clear Photosystem for proper operation.

OPTIONAL FEATURES:

Digital Radio Controls: The 6000 Series Openers covered in this Manual can be fitted with optional Radio Controls. Up to 19,683 private codes can be easily selected without use of tools. (Page 15)

Super Station (Deluxe Wall Push Button): A feature-packed accessory unit, the Super Station allows access to all of the Opener's functions. Independent Open, Close, and Stop buttons permits full control of the door's operation. The Opener's built-in light can be turned on or off independent of door operation. A Security Switch allows the Opener to be deactivated for extended periods of time. A Security Disable switch is provided if the garage door is the only entryway into the garage. Lighted Push Buttons enhance nighttime use. (Page 16)

Keyless Entry System: A tamper resistant outdoor keypad, the optional Keyless Entry System permits entry to the garage without use of key or radio transmitter. Easily programmable, it accommodates four separate access codes of 4 digits. Lighted Buttons enhance nighttime use.

★ COMPONENT IDENTIFICATION

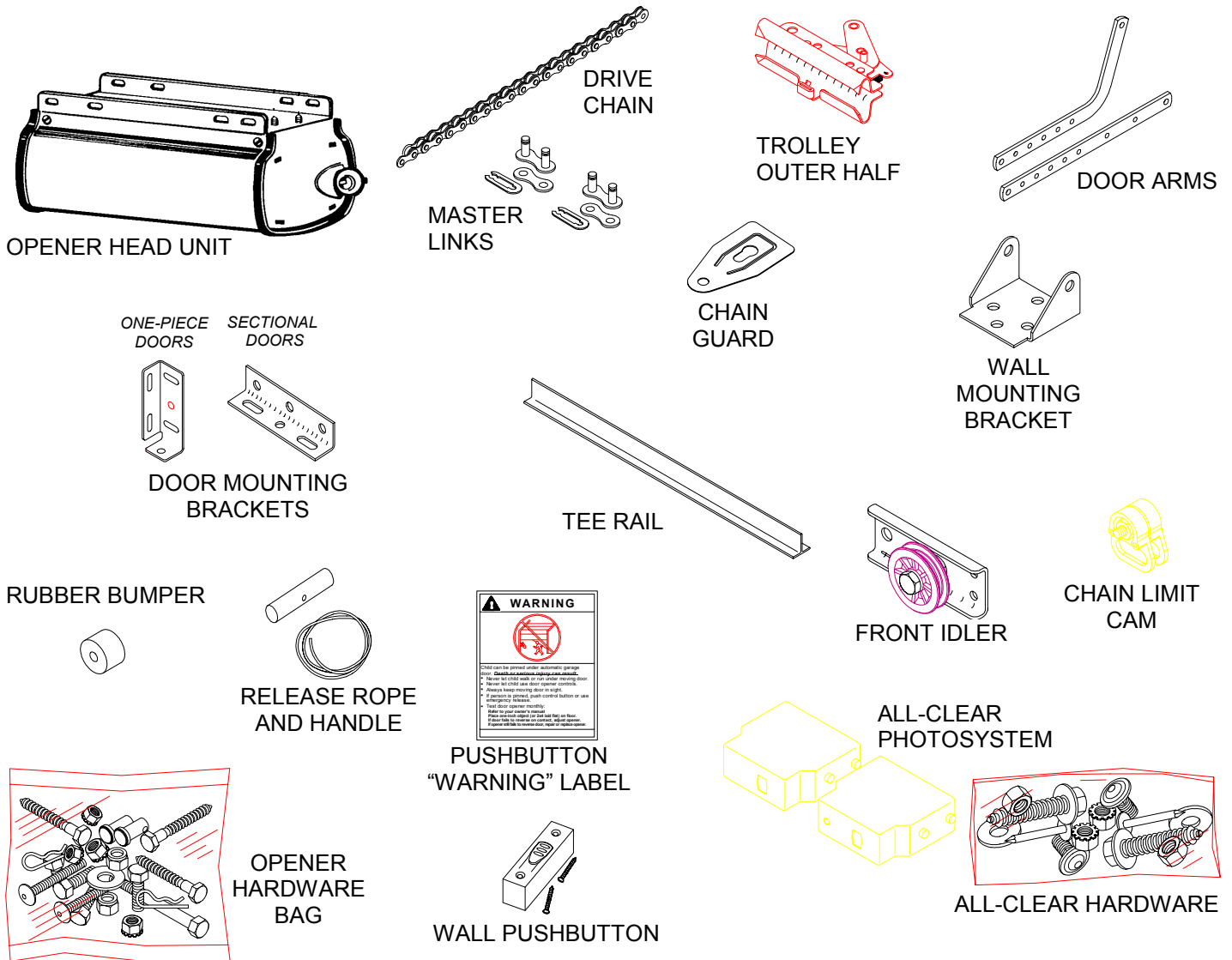

★ TOOLS REQUIRED

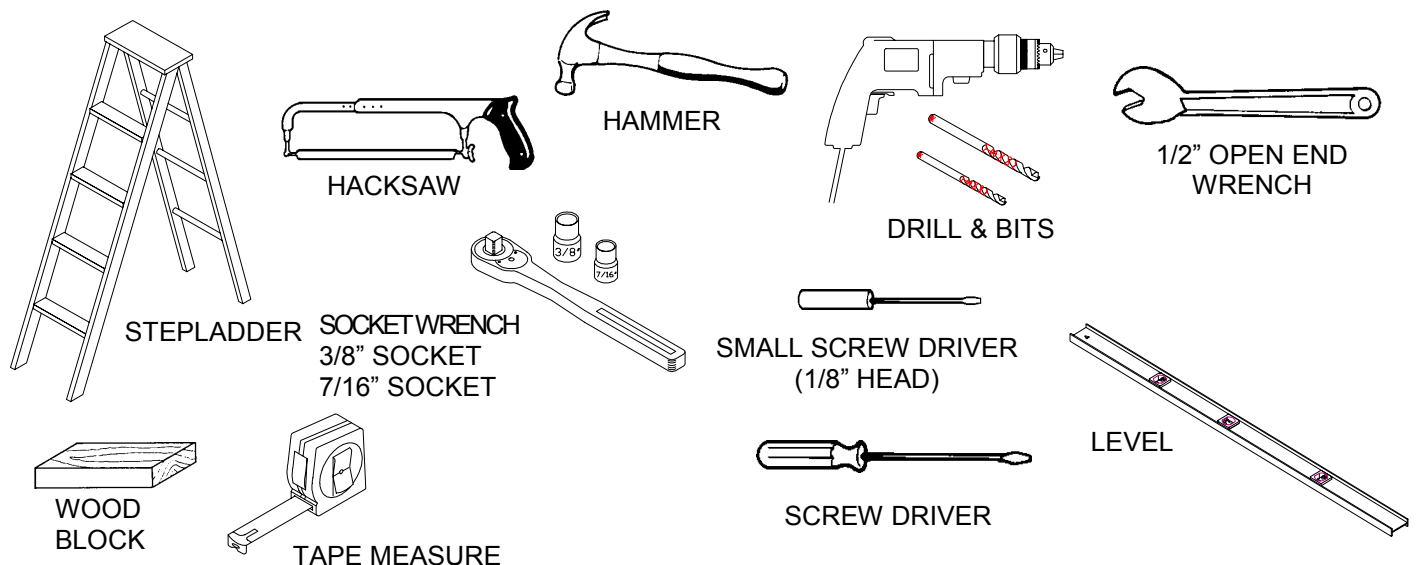

A: ASSEMBLY INSTRUCTIONS

If Your Opener Is Supplied Fully Assembled, Please Disregard This Page.

NOTE: The Tee Rail/Chain Assembly is packaged separately from the Power Unit. The Inner Trolley half, Front Idler Sprocket, Chain, Restraining Device and Limit Cams are assembled on the Tee Rail at the factory. Follow the steps outlined below to complete assembly prior to installation. Refer to the component identification illustrations on the previous page.

STEP 1: Protect the Power Unit cover from scratching during assembly by placing it on cardboard. Remove the two 5/16"-18 washered nuts and save them for later use.

STEP 2: Position the Tee Rail/Chain Assembly box near the Power Unit. Open the box and locate the Installation Hardware Packet.

STEP 3: Locate the Outer Trolley half (packaged with the Power Unit) and slide it onto the Tee Rail/Chain Assembly with the **arrow on the Trolley pointing toward the Door (Front Idler)**.

STEP 4: Using a 1/2" wrench, loosen the outer nut on the Chain Tension Bracket until it is at the end of the threaded rod. **Remove and discard** the small "S" hook used to keep the chain tight during shipping.

STEP 5: Loop the chain around the Idler and Drive Sprocket on top of the Power Unit and then position the Tee Rail on the studs. Secure with the two nuts removed in Step 1.

Slightly tension the Chain by tightening the outer nut on the Chain Tension Bracket. **Remove and discard** the tape at each end of the Tee Rail Assembly. After double-checking the Chain's alignment with the Drive Sprocket and Front Idler Wheel, use the inner and outer adjusting nuts on the Chain Tension Bracket to adjust the chain to the proper tension, making sure the chain does not twist. **When correctly adjusted, the Chain should show no droop and be approximately 1/2" above the base of the Tee Rail.**

NOTE: If the chain is too loose or too tight, improper operation and/or excessive sprocket noise may result.

STEP 6: Position the open and close Limit Switch Actuators to accept the Limit Cams on the chain, as shown. Install the Chain Guard by sliding the key-shaped hole onto the groove on the Idler Sprocket Shaft and fully seating the rear hole over the Drive Sprocket Shaft. The Limit Cams are installed at the factory. Their settings should be considered temporary and may be changed as required during installation.

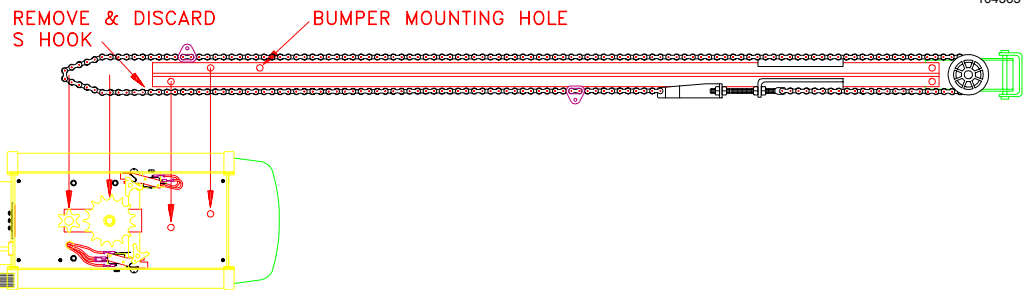

STEP 7: Install the Rubber Bumper into its mounting hole on the Tee Rail (see illustration above for location). Secure the Bumper to the bottom of the Tee Rail using one 5/16"-18 X 1" hex head bolt and one 5/16"-18 washered nut (supplied). Tighten the bolt a **MAXIMUM** of 1.5 turns after the bolt and nut are snug.

STEP 8: Recheck the nuts used to secure the Tee Rail to the Power Unit, making sure they are tight. **Recheck** the Chain tension, Chain twist, Chain Guard and the position of both the Close Limit Switch and Open Limit Switch Actuators.

Assembly is now complete and you are ready to begin installation of the opener.

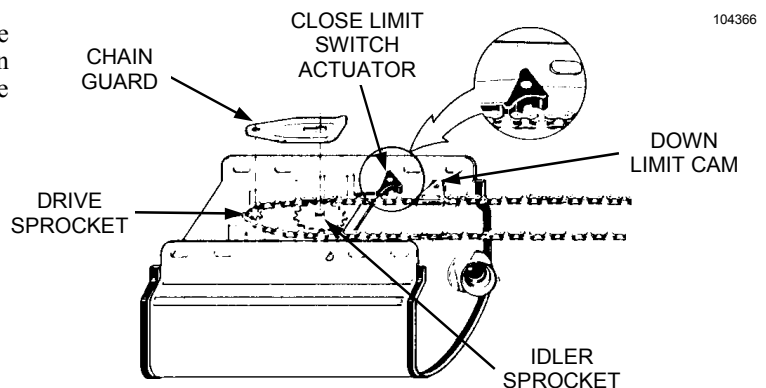



WARNING!

TO REDUCE THE RISK OF SEVERE INJURY OR DEATH: READ AND FOLLOW ALL INSTALLATION INSTRUCTIONS!

⚠ WARNING: AN UNBALANCED DOOR OR ONE THAT STICKS OR BINDS MAY PREVENT THE SENSING SYSTEM FROM WORKING PROPERLY, CAUSING INJURY OR DEATH. ENSURE DOOR IS PROPERLY BALANCED AND ELIMINATE ANY STICKING OR BINDING PRIOR TO INSTALLATION OF OPERATOR.

- A properly balanced door will open slowly from a 3/4 open position, close slowly from a 3/4 closed position, and remain still at a 1/2 open position. If the door is not properly balanced, HAVE A QUALIFIED SERVICE PERSON MAKE REPAIRS TO CABLES, SPRING ASSEMBLIES AND OTHER DOOR HARDWARE BEFORE INSTALLING THE OPENER

⚠ WARNING: YOUR GARAGE DOOR IS THE LARGEST MOVING OBJECT IN YOUR HOUSE, THE SPRINGS, PULLEYS, CABLES AND MOUNTING HARDWARE UTILIZED TO BALANCE ITS OPERATION ARE UNDER EXTREME TENSION AT ALL TIMES AND CAN CAUSE SERIOUS PERSONAL INJURY, EVEN DEATH, IF DISTURBED. DO NOT ATTEMPT ADJUSTMENT.

- CALL A QUALIFIED SERVICE PERSON TO MOVE, LOOSEN OR ADJUST DOOR SPRINGS OR HARDWARE.
- REMOVE ALL ROPES AND REMOVE OR MAKE INOPERATIVE ALL LOCKS CONNECTED TO THE GARAGE DOOR BEFORE INSTALLING THE OPENER.
- DO NOT WEAR RINGS, WATCHES OR LOOSE CLOTHING WHILE INSTALLING OR SERVICING GARAGE DOOR OPENERS. WEAR SAFETY GOGGLES OR OTHER PROTECTIVE EYEWEAR.
- IF POSSIBLE, INSTALL THE DOOR OPENER 7 FT OR MORE ABOVE THE FLOOR. MOUNT THE EMERGENCY RELEASE 6 FT ABOVE THE FLOOR.

- REINFORCE LIGHTWEIGHT FIBERGLASS, ALUMINUM AND STEEL DOOR TOP SECTIONS TO AVOID DAMAGE AND TO INSURE PROPER OPERATION OF THE SAFETY REVERSE SYSTEM. **CONTACT YOUR DOOR MANUFACTURER FOR A REINFORCEMENT KIT.**
- DO NOT CONNECT THE OPENER TO A POWER SOURCE UNTIL INSTRUCTED TO DO SO.
- CHECK LOCAL BUILDING AND ELECTRICAL CODES FOR MANDATORY INSTALLATION AND WIRING REQUIREMENTS.
- CONNECT POWER CORD ONLY TO A PROPERLY GROUNDED OUTLET. IF PERMANENT WIRING IS REQUIRED BY CODES, DISCONNECT POWER AT FUSE BOX OR CIRCUIT BREAKER BEFORE ATTEMPTING ANY WIRING CONNECTIONS.
- LOCATE THE CONTROL PUSH BUTTON:
 - A. WITHIN SIGHT OF THE DOOR, AND,
 - B. AT A MINIMUM HEIGHT OF 5 FT SO SMALL CHILDREN CAN'T REACH IT, AND,
 - C. AWAY FROM MOVING PARTS OF THE DOOR.
- INSTALL THE ENTRAPMENT WARNING LABEL NEXT TO THE CONTROL PUSH BUTTON IN A PROMINENT LOCATION. INSTALL THE EMERGENCY RELEASE INSTRUCTION CARD, ATTACHING IT ON OR NEXT TO THE EMERGENCY RELEASE.
- ADJUST THE SENSITIVITY ADJUSTMENTS ENOUGH TO ALLOW THE DOOR TO OPERATE, BUT NOT SO FIRMLY AS TO EXERT EXCESSIVE PRESSURE ON AN OBSTRUCTION BEFORE REVERSING.
- AFTER INSTALLING THE OPENER, THE DOOR SHOULD REVERSE WHEN IT CONTACTS A 1-1/2" HIGH OBJECT (A PIECE OF STANDARD 2 X 4 BOARD LAID FLAT) ON THE FLOOR.

C: INSTALLING THE OPERATOR

IMPORTANT!
IDENTIFY YOUR DOOR TYPE FROM THOSE ILLUSTRATED BELOW AND FOLLOW INSTRUCTIONS FOR THAT TYPE OF DOOR

104367

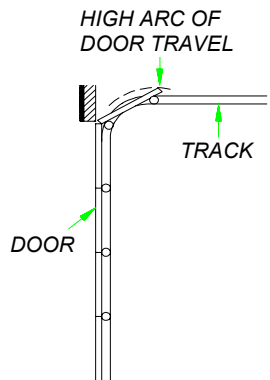
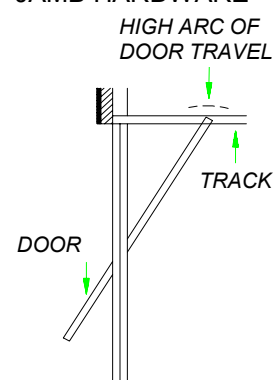
<p>SECTIONAL DOOR CURVED TRACK</p> 	<p>ONE PIECE DOOR HORIZONTAL TRACK JAMB HARDWARE</p> 
<p>FOR THESE TYPES OF DOORS USE 1/3 HP MODEL 6000 OR 1/2 HP MODEL 6500 OR 6500-P. USE 7 FT, 8 FT OR 10 FT RAIL (MATCH DOOR HEIGHT)</p>	

104368

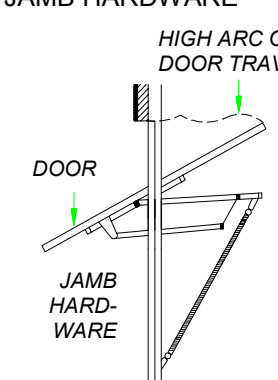
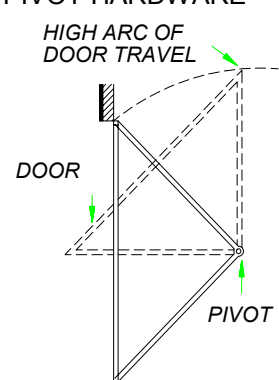
<p>ONE PIECE DOOR NO TRACK JAMB HARDWARE</p> 	<p>ONE PIECE DOOR NO TRACK PIVOT HARDWARE</p> 
<p>FOR THESE TYPES OF DOORS USE 1/2 HP MODEL J6500. USE 7J RAIL (FOR DOOR HEIGHT UP TO 8 FT)</p>	

 WARNING	<p>SPRINGS, PULLEYS, CABLES AND MOUNTING HARDWARE USED TO BALANCE YOUR GARAGE DOOR ARE UNDER EXTREME TENSION AT ALL TIMES AND CAN CAUSE SEVERE INJURY OR DEATH IF DISTURBED. DO NOT ATTEMPT ADJUSTMENT.</p>
---	--

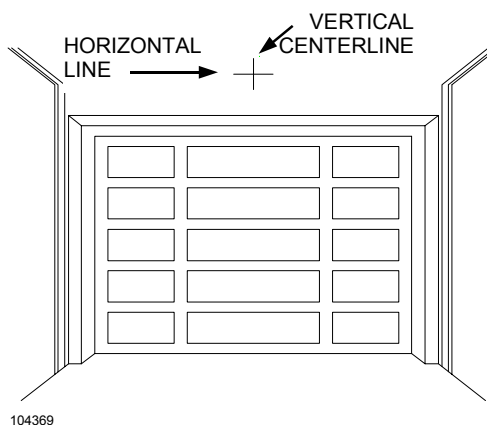

STEP 1: Mounting the Front Bracket — Sectional Doors and One-Piece Doors with Track (For One-Piece Doors without track see Step 1A, next): Manually raising the door, determine the high arc of the door's travel (see illustration, above left) and using a level, transfer this measurement to the header (see illustration at left). Draw a horizontal line, crossing the previously drawn centerline, at this point. Install the Front Mounting Bracket securely with lag screws as shown on the following page. If necessary, reinforce the header with steel angle iron or wood to ensure a secure mount.

 WARNING	<p>FRONT MOUNTING BRACKET MUST BE INSTALLED TO A STRUCTURAL SUPPORT (STUD) ON THE HEADER WALL. FAILURE TO DO SO COULD CAUSE SENSING SYSTEM TO MALFUNCTION, RESULTING IN ENTRAPMENT, INJURY OR DEATH. REINFORCE HEADER IF NECESSARY USING A 2 x 6 AND LAG SCREWS (NOT PROVIDED).</p>
---	--

★ C: INSTALLING THE OPERATOR

104370

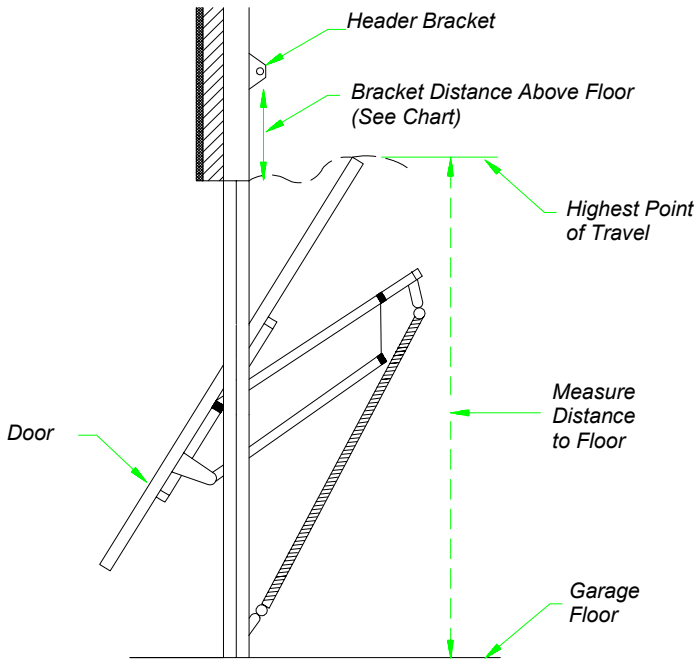

STEP 1A: Mounting the Front Bracket — One Piece Doors Without Track: Mark a vertical centerline on the header above the door. Manually raise the door to its high arc position and temporarily clamp in that position. With the door in this high arc position, measure the distance from the top of the door to the floor (see figure at left). Subtract the actual door height from the high arc distance to the floor. This is the high arc rise of the door. Unclamp and close the door. Using the table below, draw a horizontal line at the appropriate height above the door to intersect with the vertical centerline.

HIGH ARC RISE	HIGH ARC RISE HORIZONTAL LINE
4 INCHES	6 INCHES
4 TO 8 INCHES	11 INCHES
8 TO 12 INCHES	16 INCHES

Mount the Front Mounting Bracket securely with lag screws as shown in figure below. If necessary, reinforce the header with steel angle iron or wood to ensure a secure mount.

104371

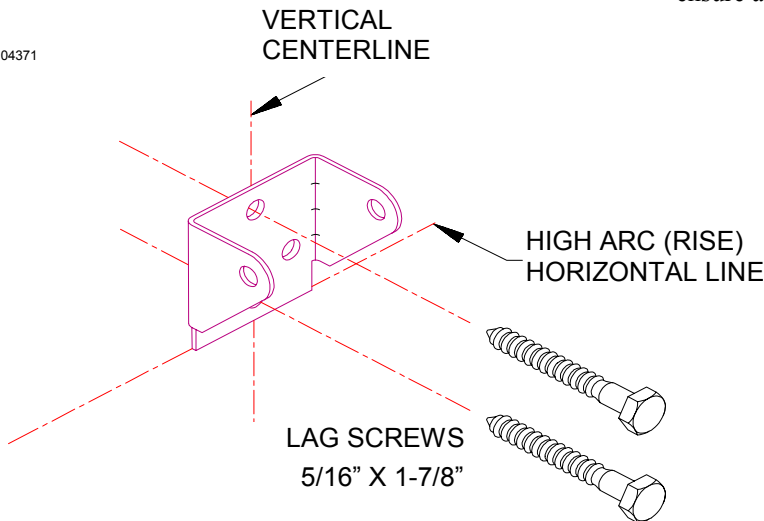

C: INSTALLING THE OPERATOR

STEP 2: Raise the Tee Rail so that the Front Idler Bracket and Front Mounting Bracket align. Insert bolt and tighten nut loosely for now. Later in the installation, this nut must be tightened securely.

STEP 3 — Sectional Doors and One Piece Doors with Track: Raise the Opener and rest the Power Unit on a ladder or other sturdy support. Open the door the full open position. Allow 2" of space between the Tee Rail and the top section of the door (as shown in the illustration, below, far left).

STEP 3A — One Piece Doors without Track: Raise the opener and rest the power unit on a ladder or other sturdy support. Open the door to the high arc position. Allow 2" of space between the tee rail and the door (at the high arc position) as shown in the illustration, below, left. The opener will be angled as shown. This is necessary for proper operation.

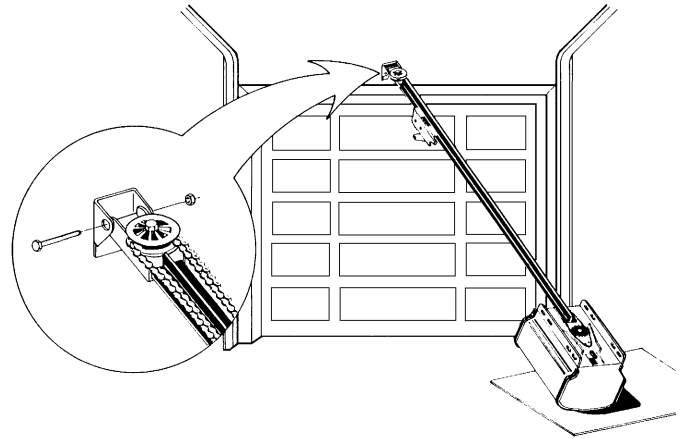

104372

NOTE: Since the Opener will be secured permanently in this position, open and close the door a few times to be sure the door does not rub on the Tee Rail and that you have allowed the proper clearances before proceeding.

SECTIONAL DOORS AND ONE-PIECE DOORS WITH TRACKS

ONE PIECE DOORS WITHOUT TRACKS

STEP 4: Mount Power Head to Ceiling: Since there is such variety in ceiling structures, all the mounting possibilities for the Power Unit cannot be illustrated here. The main concern is mounting the Power Unit securely to the ceiling joists for operational strength, rigidity and safety. Although there are a series of mounting slots provided on the power unit, try to **secure the mounting straps in the slots closest to the front**. Mounting may usually be accomplished using standard 1-1/4" perforated steel angle available at most hardware stores. If in doubt about location of, and attachment to, ceiling joists, a carpenter should be contacted to provide assistance. A cross brace will be necessary if power head is mounted 8" or more from the ceiling.

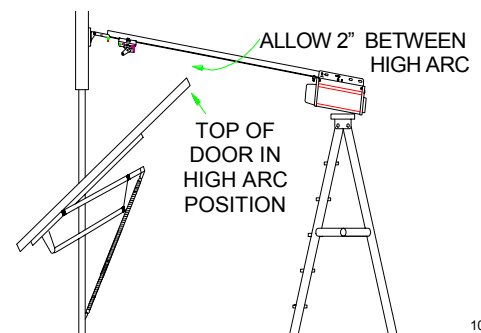
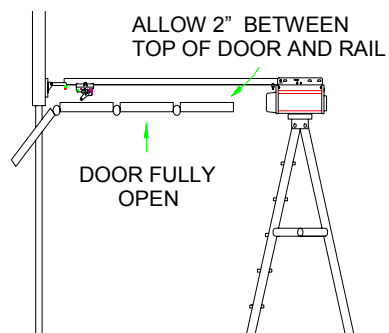

104373

STEP 5: Return to the Tee Rail/Front Mounting Bracket and securely tighten the bolt and nut that connect the Tee Rail Front Idler bracket and the Front Mounting Bracket. (See Step 2, above).

104375

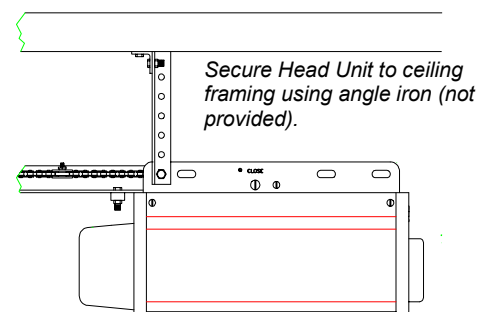
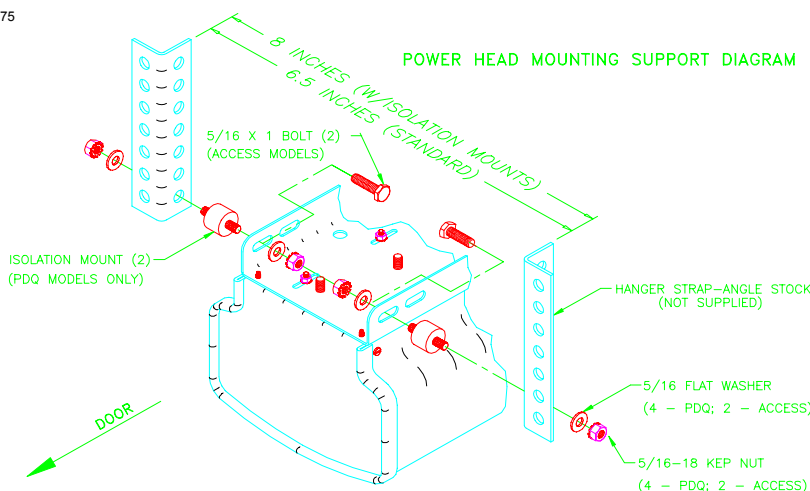

104374

NOTE: The Model 6500-P is provided with vibration isolator mounts. Position as shown above.

★ C: INSTALLING THE



CAUTION!

FIBERGLASS, ALUMINUM OR LIGHTWEIGHT STEEL GARAGE DOORS WILL REQUIRE REINFORCEMENT BEFORE INSTALLATION OF DOOR MOUNTING BRACKET. CONTACT YOUR DOOR MANUFACTURER FOR A REINFORCEMENT KIT

STEP 6: DOOR ARM CONNECTION AND INSTALLATION

NOTE: If the door is of light construction it may be necessary to reinforce the center stile with steel angle or wood to prevent damage to the door if it encounters an obstruction on closing.

104376

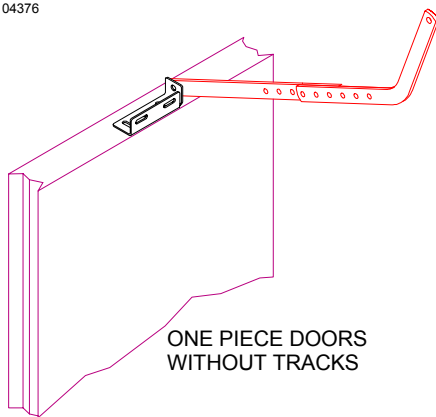

SECTIONAL DOORS AND ONE-PIECE DOORS WITH TRACKS:

Install the door mounting bracket on center and even with the top set of rollers on the door as illustrated. Connect the straight Door Arm section (single hole end) to the Trolley using a clevis pin and clip provided. Connect the curved Door Arm section (single hole end) to the door mounting bracket using a clevis pin and clip, provided. The Door Arm must pivot freely. Connect the two Door Arm sections with the 5/16" nuts and bolts provided, adjusting the length of the Door Arm so that it leans toward the Power Unit as illustrated. Do not install the Door Arm so that it is straight up and down when the door is closed or the Emergency Release will not function properly.

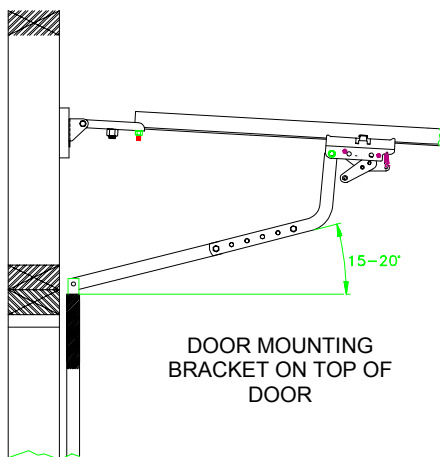
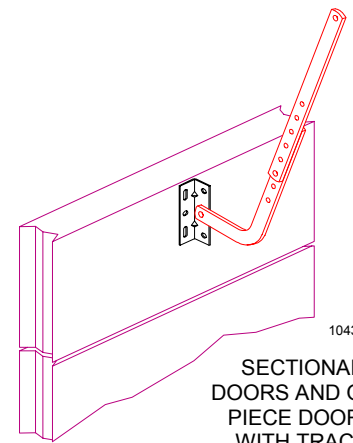

ONE-PIECE DOORS WITHOUT TRACKS:

Install the Door Mounting Bracket on the top edge of the door at center as illustrated. Connect the curved Door Arm section (single hole end) to the Trolley using a clevis pin and clip provided. Connect the straight Door Arm section (single hole end) to the door mounting bracket using a clevis pin and clip, provided. The Door Arm must pivot freely. Connect the two Door Arm sections with the 5/16" nuts and bolts provided, adjusting the length of the Door Arm so the straight portion is at a 15-20 degree angle with respect to the floor.

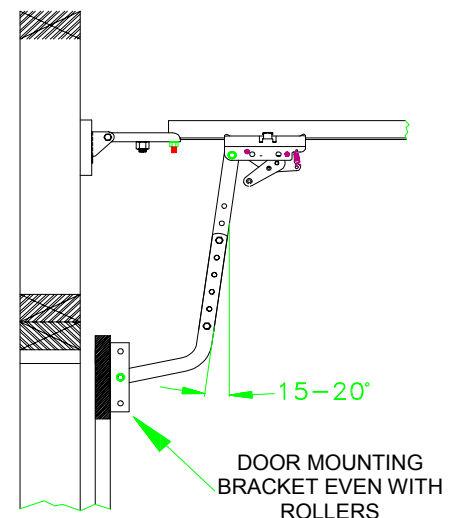

C: INSTALLING THE OPERATOR

STEP 7: Tie a **double overhand knot** in one end of the Emergency Release Rope and slip the other end through the red Release Handle, the Release Instruction Card, and the hole at the end of the Release Lever on the Trolley. Tie a second **double overhand knot in the free end**, adjusting the Rope so that the **Red Handle is 6 FT above the floor**. If the Rope must be cut, flame seal the cut end with a match or lighter.

NOTE: The Emergency Release Mechanism is engaged by pulling the Release Handle down and away from the door. This allows the Trolley Mechanism to separate, freeing the door from the Opener's transport mechanism. To re-engage, simply move the Emergency Release Mechanism Lever forward and then operate normally using the Push Button or Radio Control. The two parts of the Trolley Mechanism will automatically reconnect.

STEP 8: Connect the standard wall Push Button provided to **Terminals 1 & 0** on the Opener's rear panel using a length of 2-conductor, minimum 22 gauge wire. For mounting the standard Push Button, select a convenient location near an access door. **Mount at least 5 FT from the floor to prevent small children from operating the door.** Install the Caution Label supplied with the Opener near this installation.

If you are installing a Super Station (Deluxe Wall Push Button), See Page 16 for the proper wiring procedure.

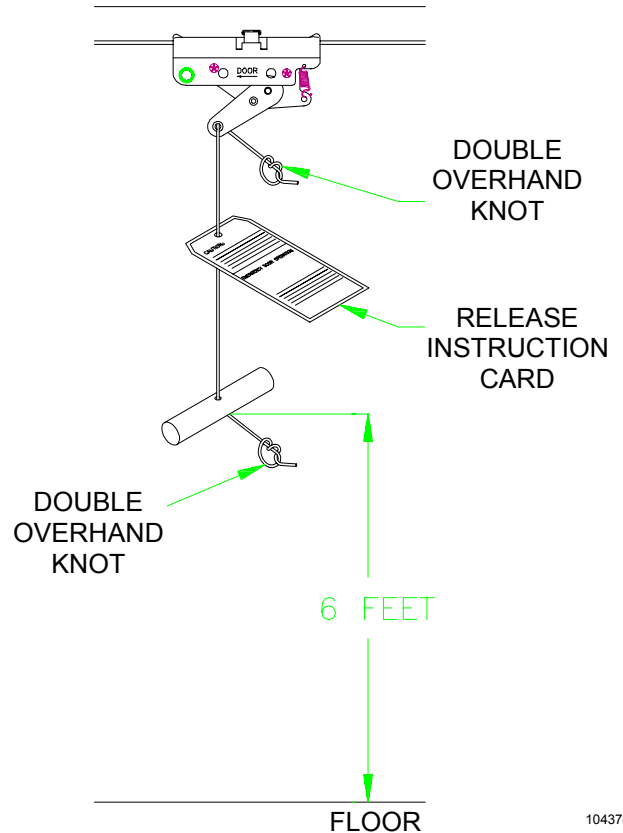

108385

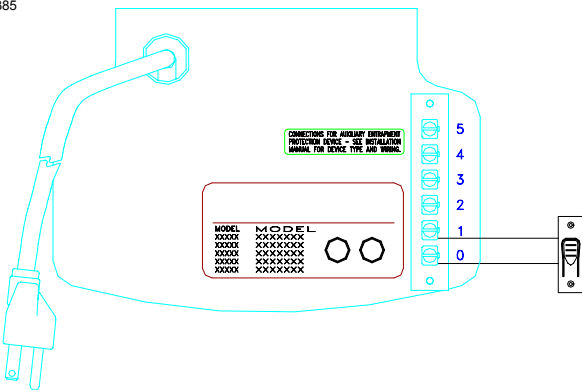

104378



WARNING

KEEP PEOPLE AND OBJECTS OUT OF DOOR OPENING WHEN USING MANUAL DISCONNECT. AN OPEN OR PARTIALLY OPEN DOOR MAY FALL UNCONTROLLABLY IF DISCONNECTED FROM OPERATOR. CONTACT A SERVICE PROFESSIONAL TO CORRECT ANY DOOR PROBLEMS.



WARNING

A CHILD OPERATING THE DOOR CONTROLS RISKS INJURY — OR DEATH — TO HIMSELF AND OTHERS. DO NOT ALLOW CHILDREN TO OPERATE ANY DOOR CONTROLS. MOUNT THE PUSHBUTTON AT LEAST 5 FT FROM THE FLOOR, OUT OF REACH OF CHILDREN.



WARNING

IMPROPER DOOR OPERATION COULD CAUSE INJURY OR DEATH. CAUTION LABEL MUST BE MOUNTED ON WALL NEAR THE PUSHBUTTON. ALL WARNINGS AND INSTRUCTIONS ON THE LABEL SHOULD BE STRICTLY ADHERED TO.



WARNING



Child can be pinned under automatic garage door. **Death or serious injury can result.**

- Never let child walk or run under moving door.
- Never let child use door opener controls.
- Always keep moving door in sight.
- If person is pinned, push control button or use emergency release.
- Test door opener monthly:
Refer to your owner's manual
Place one-inch object (or 2x4 laid flat) on floor.
If door fails to reverse on contact, adjust opener.
If opener still fails to reverse door, repair or replace opener.

★ C: INSTALLING THE OPERATOR

STEP 9: Consult the label on the rear panel of the Opener to determine its proper working voltage. Normally it will be marked for 115V, 60 cycle operation. (If it is an export model designed for 220V, 50 cycle operation, the label will clearly indicate this.) The Opener must be plugged into a properly grounded receptacle within 3 FT of the Power Unit. **A GFI Type receptacle is recommended.** Do not use 2-prong adapters and do not use extension cords for anything more than temporary hook-up and testing purposes. Receptacle wiring should be No. 14 or heavier, and **must be in compliance with local building and electrical codes.**

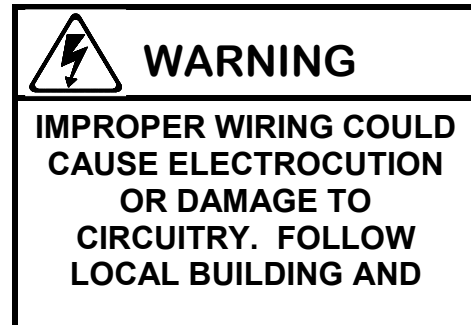
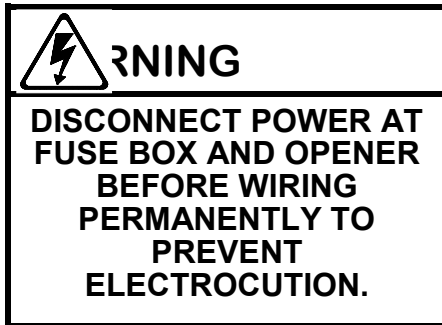

If local codes require permanent wiring, a GFI type circuit breaker is recommended to protect the line. Remove the Strain Relief Bushing and withdraw the Line Cord from the rear of the Power Unit to expose the three insulated connectors. Cut the wire at the rubber jacket of the Line Cord and wire in permanently, employing proper wiring practices. Discard Strain Relief. It is not used with permanent wiring.

Step 10: Install a **Rough Service** lamp bulb (75 Watt maximum) firmly in the light socket. Light bulbs in Door Openers are subject to vibration during normal operation which may shorten their life spans. Rough Service bulbs, available at most hardware stores, are recommended. Fit Light Diffuser tabs into the panel slots as shown.

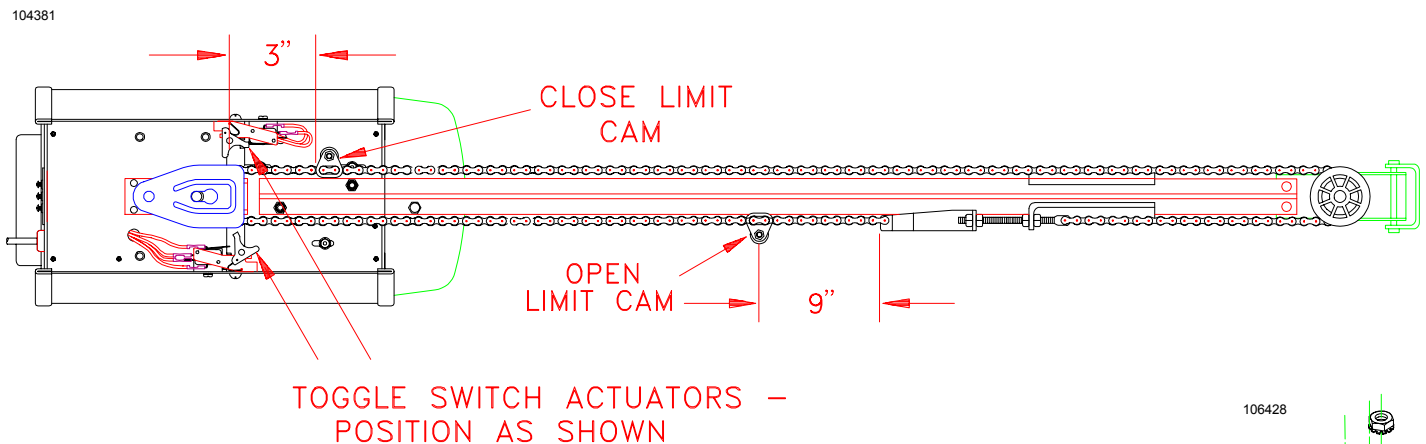
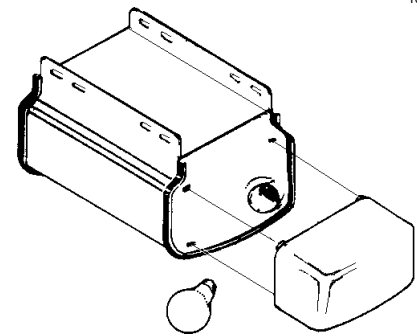

STEP 11: On most models, the Limit Cams are installed at the factory. If the Limit Cams have not been installed, fasten them to the Chain in the approximate positions illustrated above. Position the Switch Actuators as shown above.

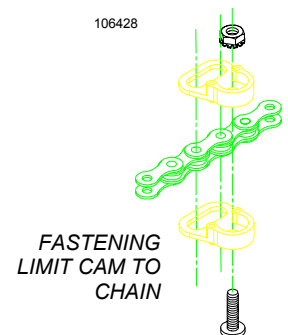



AN AUTOMATIC GARAGE DOOR SYSTEM POSES A THREAT OF INJURY OR EVEN DEATH. INSTALL THE ALL-CLEAR PHOTOSYSTEM NO HIGHER THAN 4" - 6" ABOVE THE GARAGE FLOOR TO REDUCE THE RISK TO SMALL CHILDREN.



**RISK OF ENTRAPMENT.
DISCONNECT POWER TO THE OPENER BEFORE AND DURING INSTALLATION OF THIS ACCESSORY. DO NOT RECONNECT POWER TO OPENER UNTIL INSTRUCTED TO DO SO. ENSURE DOORWAY IS CLEAR BEFORE STARTING TESTING OF UNIT.**

INSTALLATION OF 2 WIRE ALL-CLEAR PHOTOSYSTEM:

STEP 1: Mark the position of the ALL-CLEAR™ Photosystem as follows: Mark a line on the left and right door jamb (close to the door track) **FOUR (4) inches AND SIX (6) inches** above the floor. *The top mark is the maximum height and the bottom line is the minimum height that the photosystem accessory can be placed.*

STEP 2: Mount the Photosystem "L" Brackets as follows:

A. Remove the four mounting brackets from the package. Temporarily place the "U" shaped brackets, one around the receiver (unit with window and red LED) and one around the transmitter. **NOTE:** *It is easier to slip the photosystem units in from the side of the bracket than forcing them in from the front of the bracket.*

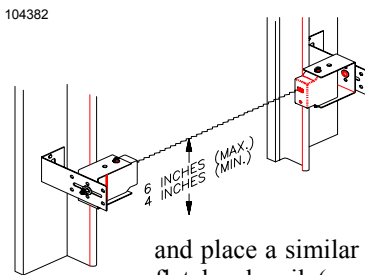

B. Your photosystem assembly is provided with a universal bracket set. Using either the transmitter or receiver (window up towards the ceiling), hold the "L" bracket and the "U" bracket set together while moving them in between the limit marks on the door jamb. Continue to move the photosystem assembly within the limit marks until it clears the door hardware. *See Illustration, left.* Check to ensure the **WINDOW ON THE FRONT OF THE PHOTOSYSTEM UNIT IS WITHIN THE LIMIT MARKS ON THE DOOR JAMB.**

C. Place a mark in the center of the lag screw elongated mounting hole. Measure its position and place a similar mark on the opposite door jamb. The brackets may be temporarily mounted to the jamb with a 1" flat head nail (provided) using the small hole above the slot. Using two 5/16" X 1-1/2" lag screws (provided), permanently mount the "L" bracket to both door jambs.

STEP 3: Connect the Photosystem as follows:

A. Remove the transmitter and receiver from their "U" mounting brackets.

Refer to Page 21 for various wiring options for the All-Clear™ Photosystem. Steps B and C, below, describe the wiring for Series Connection with Receiver First, as illustrated on Page 21.

B. Run a wire pair (not supplied) around the garage door jamb between the transmitter and receiver "L" mounting brackets. **NOTE:** Leave about 12" of extra wire at each end. Use a minimum 22 gauge solid "trace" wire for interconnect.

C. Run a wire pair (20 or 22 gage solid wire) from the receiver position (unit with "LED" light in the front, may be either side of the door) back to the rear bulkhead of the garage door opener. **NOTE:** Leave about 12" of extra wire at the receiver end and about 24" of extra wire at the opener end.

D. Strip approximately 5/16" from each wire end at the photosystem units and at the opener.

E. Using two (2) wire nuts (supplied), connect the wire ends at the ALL-CLEAR™ Photosystem transmitter to the pigtail wire ends coming out of the transmitter unit. *Although not required, it is recommended to connect the trace wire ends together and the unmarked wire ends together.*

F. Using two (2) wire nuts (supplied), connect the wire ends at the ALL-CLEAR™ Photosystem receiver to the pigtail wire ends coming out of the receiver unit. *Although not required, it is recommended to connect the trace wire ends together and the unmarked wire ends together.*

STEP 4 : Final Installation

★ D: AUXILIARY EQUIPMENT

- Attach the "U" brackets to the "L" brackets with a 1/4-20 carriage bolt, washer and hex nut (provided). Insert the bolt from the inside of the "U" bracket and hand tighten only at this time.
- Place the transmitter and receiver units into their respective "U" brackets. *See Illustration, at right.*
- Connect the interconnect wire pair to the garage door opener terminals marked "4" & "5". *Although not required, it is suggested that the "trace" be connected to Terminal 5. See Wiring Diagram, Page 21.*

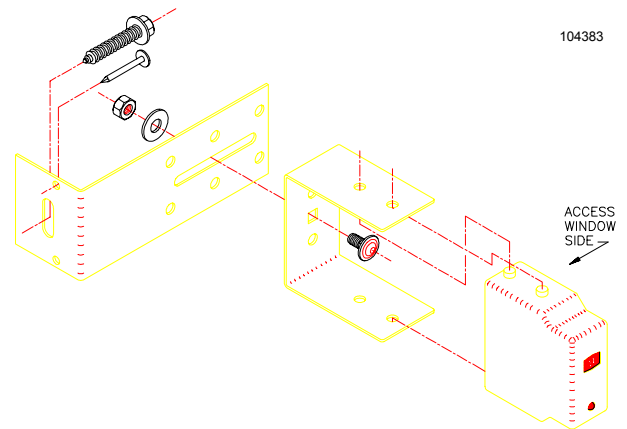

STEP 5 : Final Alignment and Test

- Reconnect the power to the Garage Door Opener. Keep a portable transmitter with you to control the garage door opener.
- Place a solid object one foot in front of the transmitter or receiver. The red LED should go **OFF** and remain **OFF** until the object is removed. **NOTE:** *There may be a slight delay in returning to normal depending upon how long the photosystem was blocked.*
- Move to the center of the door. Make sure the red LED light is on. Move a solid object slowly through the beam. The LED should go OFF and then ON. If not, check the wire connections (see Step 3).**
- At this time set or recheck the down limit adjustment and reversing system adjustment of the garage door opener following the procedure outlined in Steps 1 & 4, Pages 17 & 18. It is **VERY IMPORTANT** that the door opener's inherent features operate as intended before completing the photosystem tests.
- Place an opener insert box or a similar object (at least six inches high) on the floor at the center of the door. Now, attempt to close the door. **The door should NOT close** from the portable transmitter, but will close with constant pressure from the mechanical push button.
- Remove the obstruction from the photosystem beam's path. Close the door. Toward the bottom of the doors downward movement, **CAREFULLY** move a solid object across the path of the beam at the center of the door. The door should STOP, pause for approximately one second and OPEN. Retest, breaking the beam one foot in front of both the transmitter and receiver unit while the door is moving downward. *The door must STOP and OPEN each time. If not, re-align the photosystem until proper operation is obtained.*
- Tighten all mounting screws and bolts.

INSTALLATION OF RADIO CONTROLS:

The following instructions detail installation of Model 9931 Radio Controls. For other Radio models, see instructions packaged with product.

TRANSMITTER:

To gain access to the Transmitter Coding Switches, remove the Battery Cover from the front of the Transmitter by sliding it toward the bottom of the Transmitter as illustrated.

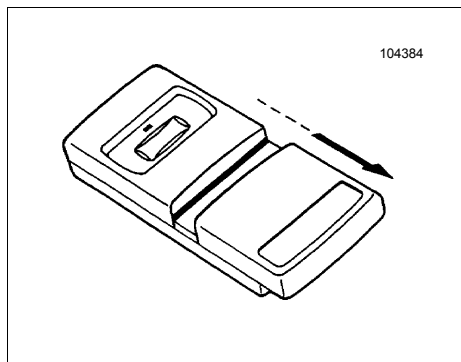

RECEIVER: The Receiver Coding Switches can be accessed by removing the small door from the back of the Receiver using a small screwdriver or knife.

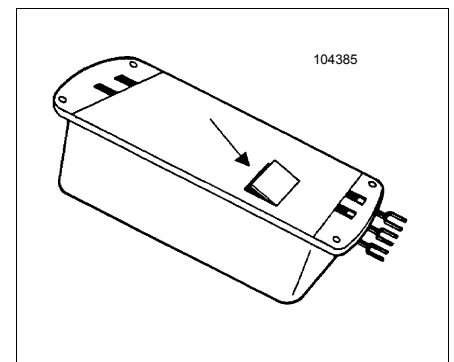

D: AUXILIARY EQUIPMENT



Setting The Coding Switches: When setting the Coding Switches THE FACTORY PRE-SET CODES MUST BE CHANGED TO PREVENT UNAUTHORIZED OPERATION. Transmitter and Receiver codes must be set IDENTICALLY. If just one Code Switch is mismatched, the Radio Controls will not function.

NOTE: For security reasons, it is advisable NOT to set all the switches in the same position.

Mounting The Receiver: After setting the Coding Switches, mount the Receiver on the rear panel of the Opener by connecting it to Terminals 1, 2 and 3. A small Plastic Pin is provided to secure the other end of the Receiver to the panel. For proper operation, the Antenna Wire should be **POINTED STRAIGHT DOWN** toward the floor.

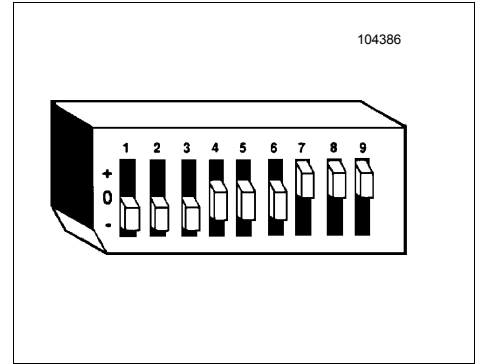

CODING BLOCK: Transmitter and Receiver Coding Switches are contained in identical Coding Blocks, consisting of nine small switches, labeled 1 - 9, each of which can be set in any of three positions, labeled +, 0, -

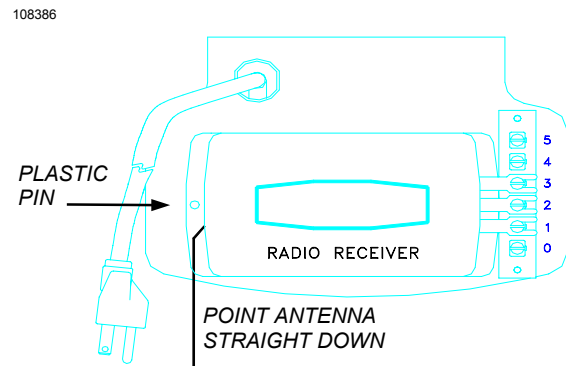

After installing the Radio Controls, check their operation by moving approximately 35 FT away from the garage door and pressing the Transmitter Button. Operation at this distance should be reliable.

If the Transmitter doesn't activate door operation, check that all Coding Switches are set identically. If the operational distance is inadequate, try

moving the position of the Transmitter in the car. If the distance is still inadequate, try bending the Antenna Wire to a different angle. If the distance is still inadequate, replace the Battery with a standard 9-Volt "transistor radio" Battery (NEDA 1604). The Battery is located in the front compartment next to the Coding Switches.

The Transmitter may be hand held if desired by removing the Visor Clip from the rear of the Case as illustrated. Place your finger in the loop at the top of the visor, and your thumb on the top edge of the Transmitter. Push down with your thumb and pull up with your finger. The clip will release and pull out easily.

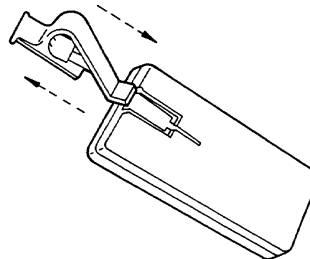

INSTALLATION OF THE SUPER STATION

The Super Station (Deluxe Wall Pushbutton Station) is an **optional accessory** designed to work with any 6000 Series Operator. Connection to any other operator may damage the operator and/or the Super Station. Only connect one operator to each Super Station. Do not connect more than one Super Station to an Operator.

STEP 1: After determining a suitable location, usually near the access door and at least 5 feet above the floor to prevent use by children, use the Super Station as a guide to mark the mounting holes. Drill holes for drywall anchors or screws. NOTE: Do not mount directly to masonry walls. Use backer board. The Super Station is also designed to be mounted directly to a standard single electrical box.

STEP 2: A length of 2-conductor, #22 gauge wire is required to connect the Super Station to the garage door operator. Strip approximately 6" of the wire jacket from one end and 1/2" of insulation from each wire. Carefully connect one wire to each of the two terminals indicated, noting which color is connected to which terminal. Tighten screws, being careful that no wires are allowed to touch any other terminal or any other conductive part of the circuit board. Do not overtighten the terminal screws.

★ D: AUXILIARY EQUIPMENT

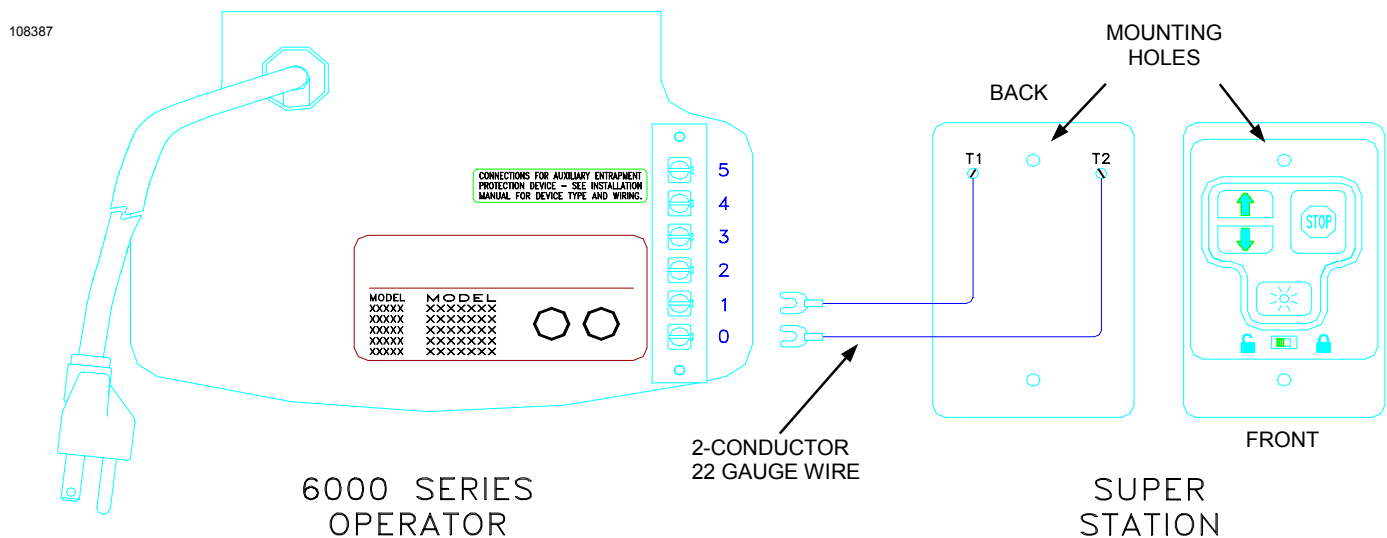

STEP 3: Push the wire jacket into one of the two notches provided at the ends of the housing, allowing a maximum of 1/8" inch of the jacket inside the case (too much will make mounting difficult). Carefully tuck the loose wires into the case and mount the unit using the screws provided.

STEP 4: Run the wire from the Super Station to the operator, supporting it at 18" intervals with suitable staples. Leave a sufficient length to make the necessary connections to the operator terminal strip.

WARNING: SOME LOCAL BUILDING CODES DO NOT ALLOW SURFACE WIRING. BE SAFE AND CHECK WITH YOUR LOCAL BUILDING INSPECTOR FIRST.

STEP 5: Disconnect the power from the operator. Strip approximately 4" of jacket from the end of the wire and 1/2" insulation from each wire. Connect to terminals 0 and 1 as shown in the illustration above. Support the wire near the operator with wire ties.

STEP 6: Reconnect power to the operator and test the Super Station functions as described in the Operation and Adjustment Instructions.

★ E: OPERATING PARAMETERS

Please note the following Operating Parameters which apply to Openers with Auxiliary Entrapment Protection System connected. (All-Clear Photosystem, Installation Instructions on Page 13.)

IF THE DOOR IS...

...**FULLY OPEN**, then pushing the standard wall Push Button or the radio control will cause the door to begin **MOVING DOWNWARD**.

...**FULLY CLOSED**, then pushing the wall Push Button or the radio control will cause the door to begin **MOVING UPWARD**.

...**MOVING UPWARD**, then pushing the wall Push Button will cause the door to **STOP**. The next push of the wall button will cause the door to begin **MOVING DOWNWARD (Alternate Action Operation)**.

...**MOVING UPWARD**, then pushing the radio control will cause the door to **STOP**. The next push of the wall button will cause the door to **RESUME UPWARD MOVEMENT (Radio Operation)**.

...**MOVING DOWNWARD**, then pushing the wall Push Button or the radio control will cause the door to **STOP, PAUSE FOR APPROXIMATELY ONE SECOND, AND THEN BEGIN MOVING UPWARD**.



IMPORTANT SAFETY INSTRUCTIONS



WARNING

TO REDUCE THE RISK OF SEVERE INJURY OR DEATH, READ AND FOLLOW ALL INSTRUCTIONS!

- **NEVER** let children operate or play with door controls. Keep the Remote Control away from children.
- **ALWAYS** keep a moving door in sight and keep people and objects away from the door area until the door is completely closed. **NO ONE SHOULD CROSS THE PATH OF A MOVING DOOR.**
- **TEST THE DOOR OPENER MONTHLY.** The door **MUST** reverse upon contact with a 1-1/2" high object (or a 2 X 4 board laid flat) on the floor. After adjusting the sensitivity or the limit of travel, **ALWAYS RETEST** the Opener. Failure to **ADJUST THE OPENER PROPERLY** may result in **SERIOUS INJURY OR DEATH.**
- If possible, **USE THE EMERGENCY RELEASE** only when the door is closed. Use caution when using the Release with the door open. **WEAK OR BROKEN SPRINGS MAY ALLOW THE DOOR TO CLOSE RAPIDLY, CAUSING SEVERE INJURY OR DEATH.**
- **KEEP THE GARAGE DOOR PROPERLY BALANCED.** See the door owner's manual. An improperly balanced door **MAY CAUSE SEVERE INJURY OR DEATH.** Have a **QUALIFIED SERVICE PERSON MAKE REPAIRS TO CABLES, SPRING ASSEMBLIES AND OTHER HARDWARE.**
- **SAVE THIS INSTRUCTION MANUAL.**

NOTE: It is now necessary to turn on the power in order to run the Opener to check limit settings. Before doing so, ensure that all mounting hardware is installed and has been properly tightened, that all electrical connections are per local code requirements, and that proper wiring practices have been followed. Also, double-check that all ropes have been removed from the door and that the doorway is clear.

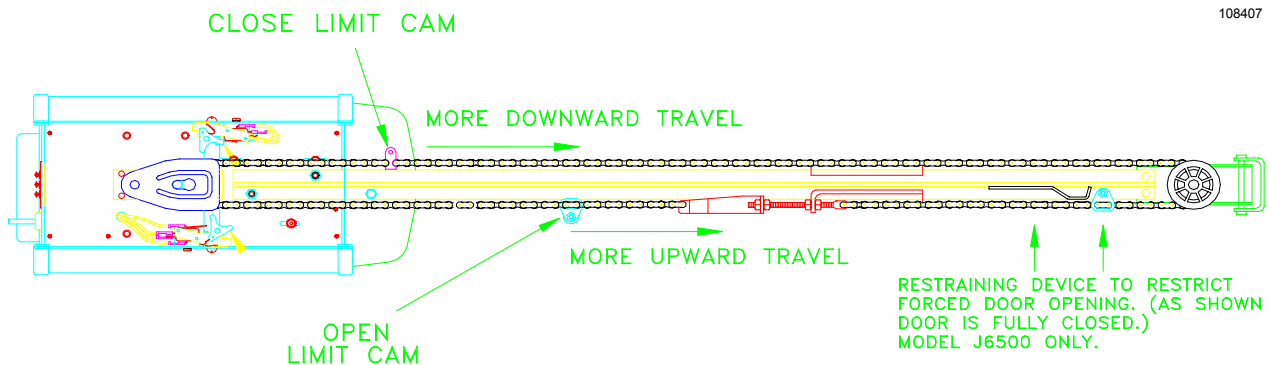

STEP 1: Testing the Limit Settings: To check the Limit Settings, start the Opener by pushing the standard wall Push Button (Mounted in Step 11). Be prepared to activate the Push Button again quickly - per the Operating Parameters outlined on Page 16 - if you see that the door is going to over travel. As illustrated above, move the Cams toward the Power Unit to **DECREASE** door travel and toward the Front Idler to **INCREASE** door travel. Adjust the Up Limit Cam so that the door comes to rest where it normally would without an electric Opener. Adjust the Down Limit Cam so that the door closes firmly without putting undue stress on the Door Arm. For Model J6500, adjust the "Restraining Device To Restrict Forced Door Opening" to the positions as shown when door is fully closed. When properly adjusted, this bracket will inhibit a forced door opening from the center of the door.



WARNING

IF LIMITS ARE NOT ADJUSTED PROPERLY, THE EMERGENCY RELEASE MECHANISM MAY NOT WORK PROPERLY AND DOOR OPERATION COULD RESULT IN DOOR DAMAGE, SERIOUS PERSONAL INJURY OR DEATH!

★ F: OPERATION AND ADJUSTMENT

STEP 2: Adjusting the Sensitivity Force — Sensitivity System force adjustment screws are located on the side rails of the Power Unit and can easily be adjusted with a screwdriver. Turn the screws **CLOCKWISE** for more force and **COUNTERCLOCKWISE** for less force.

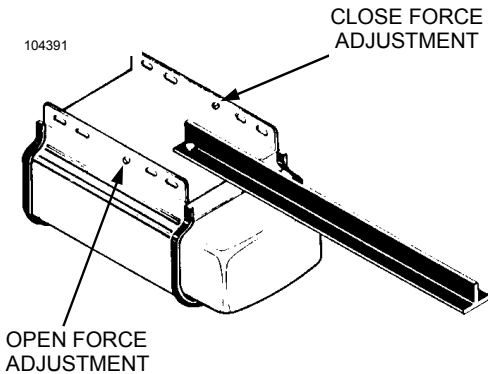

**WARNING**

IMPROPER ADJUSTMENT OF SENSITIVITY SYSTEM FORCE COULD CAUSE ENTRAPMENT, INJURY OR DEATH. SET ADJUSTMENTS FOR JUST ENOUGH FORCE TO OPERATE THE DOOR RELIABLY, BUT NO STRONGER. Contact a service professional to correct any binding, sticking or other door problems. DO NOT OVER-ADJUST SENSITIVITY SYSTEM TO COMPENSATE FOR A POORLY WORKING DOOR.

STEP 3: Testing the Sensitivity Force — To test the Sensitivity System, start the Opener and grasp the bottom door handle halfway through the door's travel (opening or closing). When testing in the **CLOSE** direction, a second person will be needed to maintain pressure on the Push Button **IF** an Auxiliary Entrapment Protection Device has not yet been fitted. If a second person is unavailable, use a stiff cardboard carton placed in the door's downward path to indicate the force the Opener is exerting. If the force adjustment screws are properly set, the door should stop if opening, and reverse if closing without exerting undue pressure.

STEP 4: Testing the Opener's Reversing System — To test the Opener's Reversing Feature at floor level, place a solid object 1-1/2" thick (such as a standard 2 X 4 board laid flat) on the ground where the center of the door will contact it. Close the door. If the down force adjustments are correct, the door will reverse within two seconds of contacting the object and travel to the Full Open position. If this does not occur, recheck the Limit Adjustments (Page 17) and Sensitivity Adjustments (Step 2 & 3, Above).

NOTE: Any time adjustments are made to Limits or Sensitivity, YOU MUST RETEST THE OPENER FOR THE REVERSING FEATURE AT FLOOR LEVEL AS OUTLINED ABOVE.

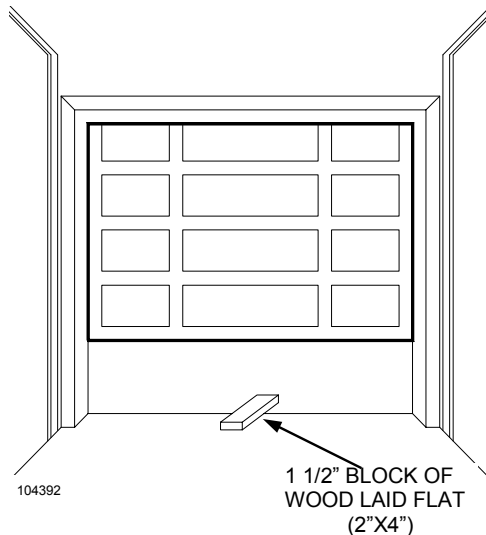

**WARNING**

FAILURE TO TEST REVERSING SYSTEM COULD RESULT IN DEATH OR SERIOUS INJURY. TEST THIS SYSTEM ONCE A MONTH BY FOLLOWING PROCEDURES OUTLINED

**WARNING**

THE SENSITIVITY SYSTEM REVERSING TEST SHOULD BE PERFORMED MONTHLY TO ENSURE THAT THIS IMPORTANT SYSTEM REMAINS IN PROPER ADJUSTMENT.

F: OPERATION AND ADJUSTMENT INSTRUCTIONS



A DAMAGED OR MALFUNCTIONING PHOTOELECTRIC ACCESSORY SYSTEM COULD ENABLE A GARAGE DOOR TO CLOSE ON PEOPLE OR PROPERTY, CAUSING SERIOUS INJURY OR DEATH. PERFORM THIS TEST MONTHLY TO ENSURE YOUR ALL-CLEAR IS WORKING PROPERLY.

STEP 5: Testing the All-Clear™ Photosystem —

Start the door in the close travel direction and then place an obstacle approximately 8" high by 12" wide in the path of the beam. The Red Pilot Light on the All-Clear™ Photosystem should go out. The door should stop and reverse to the full open position.

With the door fully open and at rest, place the obstacle in the path of the beam once again. Activate the Standard Wall Push Button. The opener should revert to and remain in the PUSH AND HOLD mode of operation for close travel.

IF THE GARAGE DOOR TRAVELS MORE THAN ONE INCH IN A DOWNWARD PATH AFTER RELEASING THE BUTTON, THE ALL-CLEAR™ SYSTEM IS MALFUNCTIONING. CHECK THE ELECTRICAL CONNECTIONS AND ALIGNMENT OF THE ALL-CLEAR™.

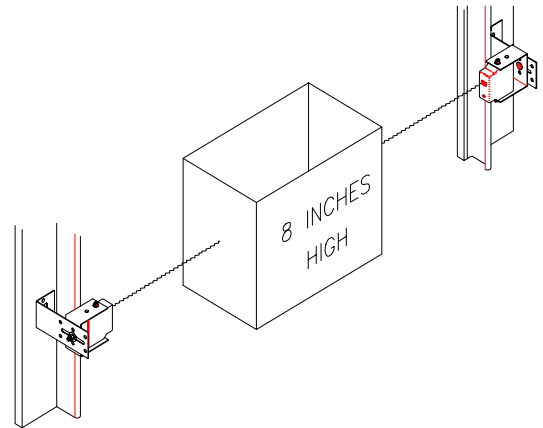

104393

STEP 6: Operating the Super Station (Deluxe Wall Pushbutton Station) Controls — The Super Station replaces standard doorbell-type pushbuttons to allow you to integrate fully with all the convenience and security features built into your 6000 Series garage door operator.

- 1. Operator Open Pushbutton** — Green-backlighting, arrow pointing up. Used to start the door upward. This button will also stop and reverse a door that is closing. The button has no effect on a door that is opening. The function of this pushbutton is automatically disabled when the Security slide switch is set to the “ON” position and the door is fully closed.
- 2. Operator Close Pushbutton** — Green-backlighting, arrow pointing down. Used to start the door downward. This button has no effect on a door in motion.
- 3. Operator Stop Button** - Red-backlighting, universal “STOP” within an octagon. Used to stop a door in motion. This button has no effect on a door that is stopped.

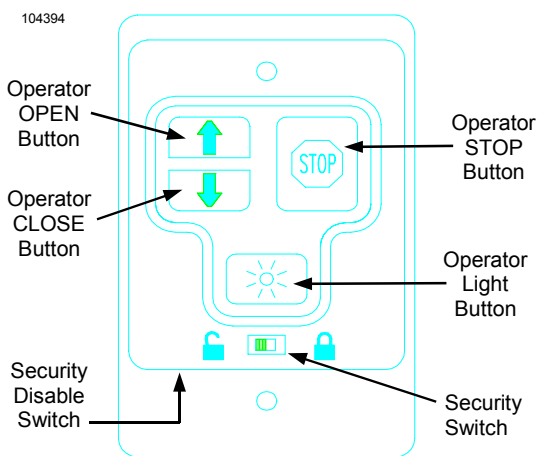

4. Operator Light Pushbutton — Yellow-backlighting, “Sun” symbol. Turns the operator light on and off, but does not activate the door operator. The operator light will stay on until turned off using this pushbutton, or until door operation is initiated, which overrides the function of this pushbutton and automatically turns the light off after 4-1/2 minutes.

5. Security Switch — Prevents unwanted door operation from pushbutton, key switches, keyless entry systems, radio controls, etc. When the Security Switch is moved to the ON position (towards “locked” symbol), with the garage door fully closed, signals from all of these devices are locked out by the operator. Such devices will continue to work until the door is fully closed, allowing you to set the switch (when leaving on vacation, for example), leave the garage and close the door remotely.

(NOTE: YOU WILL NOT BE ABLE TO OPEN YOUR GARAGE DOOR USING RADIO CONTROLS OR EXTERIOR ACCESS CONTROLS UNTIL THE SECURITY SWITCH IS RETURNED TO THE OFF POSITION (“unlocked” symbol). THIS MUST BE DONE FROM INSIDE THE GARAGE.) When the Security Switch is engaged, the green lighting behind the Open/Close Pushbuttons is extinguished as an indication.

6. Security Disable Switch - located under and to the left of the Security Switch. Disables the Security Switch feature. Use if the garage door is the only entryway to the garage.

★ OPERATOR WIRING DIAGRAM

1003939

For Opener Models: 6000, 6500, 6500-P and J6500

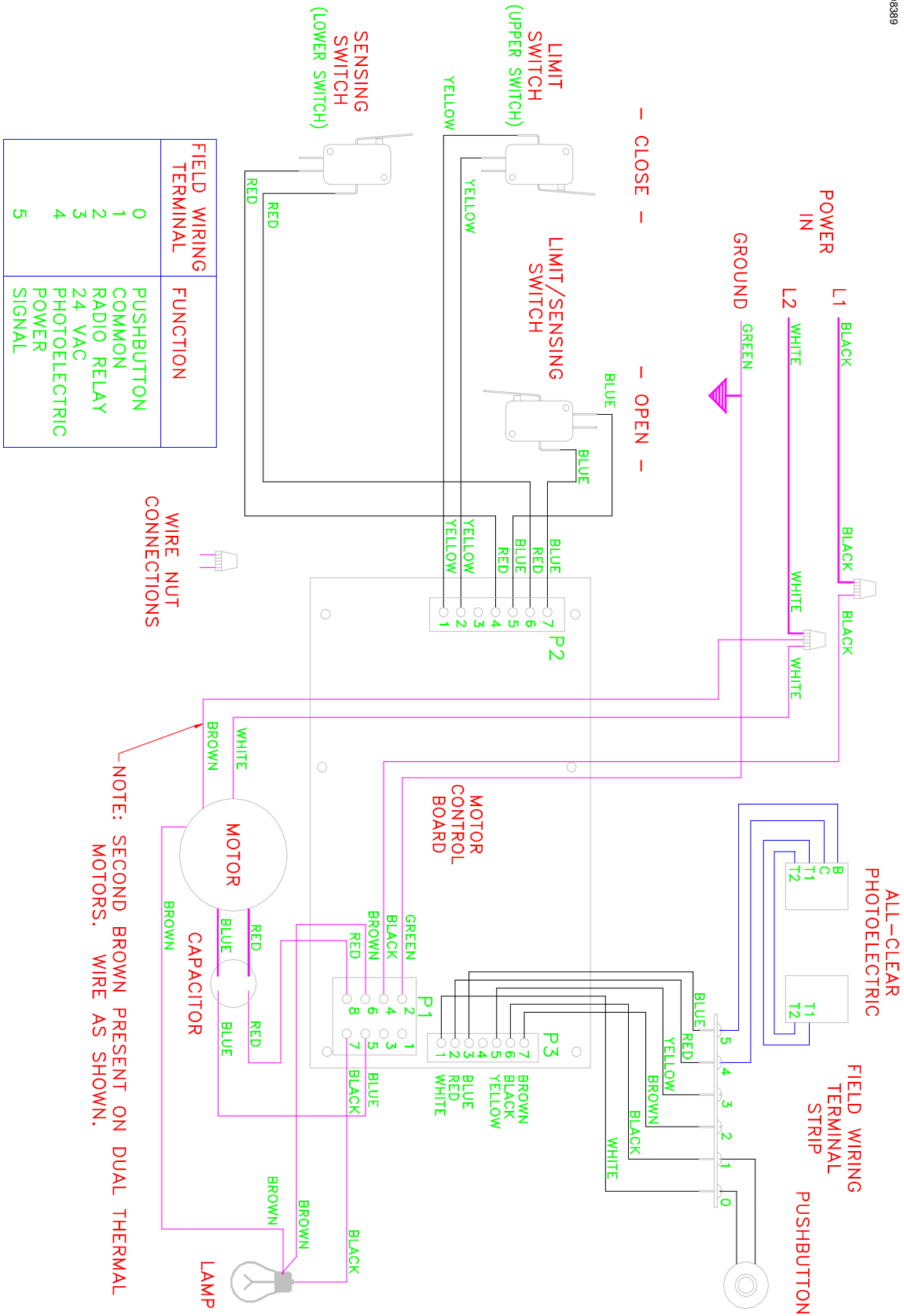

WIRING AUXILIARY EQUIPMENT



PHOTOCELL SERIES CONNECTION (RECEIVER FIRST)

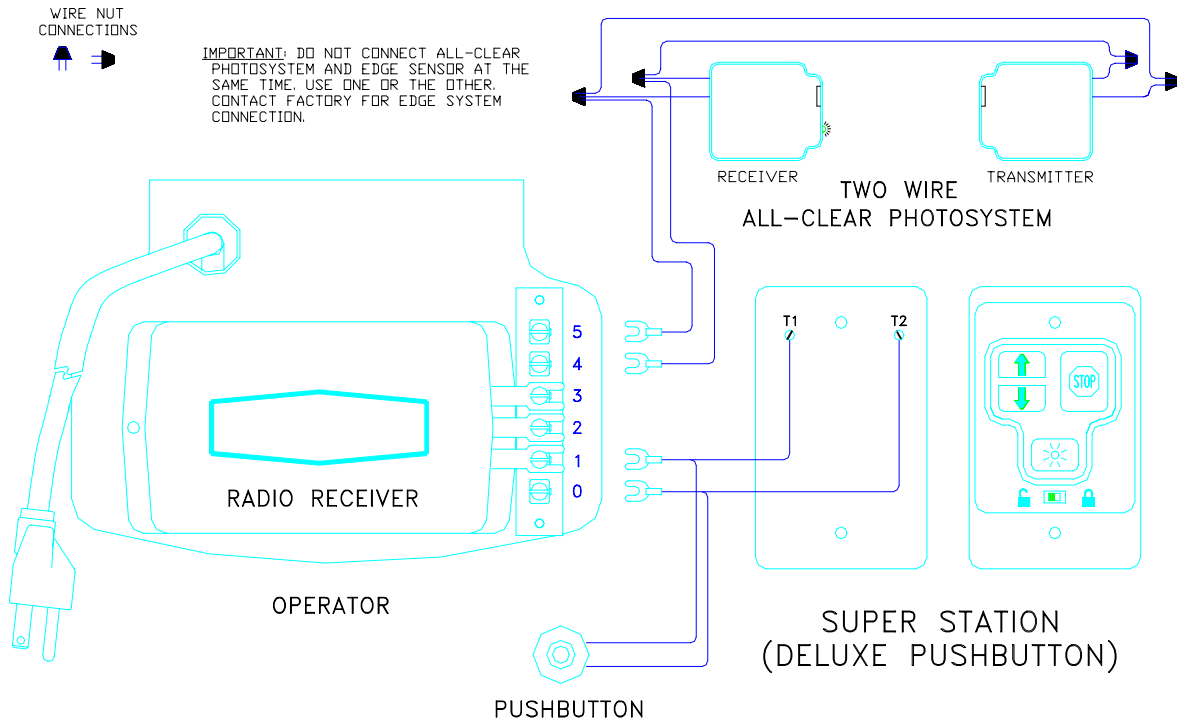

108971

PHOTOCELL PARALLEL CONNECTION

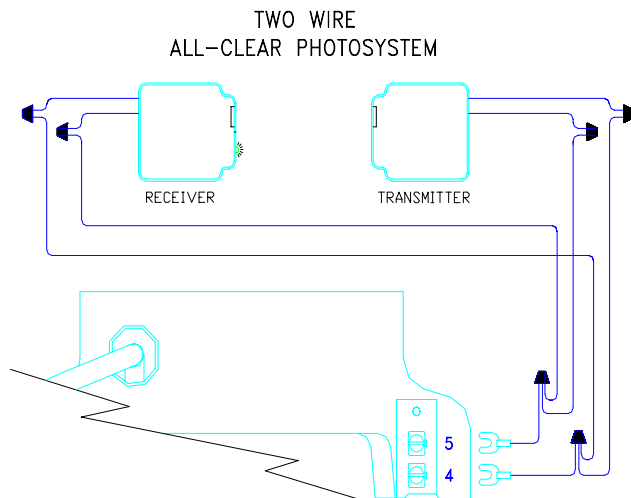

PHOTOCELL SERIES CONNECTION (TRANSMITTER FIRST)

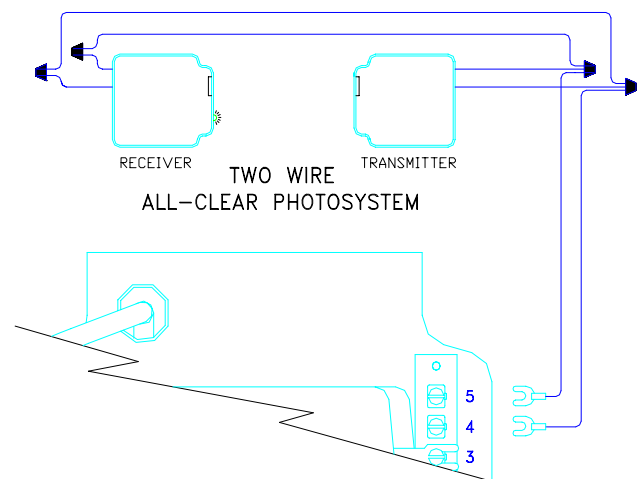

Your 6000 Series Residential Garage Door Opener is furnished with an enhanced 2 Wire All-Clear™ Photosystem. New features include:

Time-Saving Electrical Connections. No screw terminals! Just strip the ends of the wires back 5/16 inch and use the supplied wire nut connectors for a quick hook-up to pre-wired garages or to the wires you run on site. See the figure above applicable to your installation.

Universal Wiring Capabilities. The All-Clear™ Photosystem can be wired in series or parallel combinations. Virtually any existing wiring can be used. See the figures above.

Improved Sunlight Immunity. Under certain conditions, direct sunlight can overpower photobeam systems. We have provided an extra internal circuitry to reduce sunlight problems. When required, the position of the transmitter and receiver may be interchanged with out rewiring.



INSTALLATION CHECKLIST

BEFORE PLACING DOOR OPERATOR IN REGULAR SERVICE, MAKE SURE THAT:

- 1. THE FRONT AND REAR MOUNTS FOR THE OPENER ARE SOUND AND SECURE AND THE RAIL IS POSITIONED CORRECTLY ABOVE THE HIGH ARC OF THE DOOR, AND THAT THE OPENER IS POSITIONED OVER THE DOOR ACTION CENTERLINE.**
- 2. FOR SECTIONAL DOORS AND ONE-PIECE DOORS WITH TRACKS, THE POSITION OF THE DOOR ARM, WITH THE DOOR CLOSED, IS SUCH THAT ITS CONNECTING POINT ON THE TROLLEY IS 5" TO 8" BEHIND ITS CONNECTING POINT ON THE DOOR BRACKET. THE DOOR ARM SHOULD NEVER BE PERFECTLY VERTICAL WHEN THE DOOR IS IN THE CLOSED POSITION.**

FOR ONE-PIECE DOORS WITHOUT TRACKS, THE POSITION OF THE DOOR ARM, WITH THE DOOR CLOSED, IS SUCH THAT ITS CONNECTING POINT ON THE TROLLEY IS 20" TO 22" BEHIND ITS CONNECTING POINT ON THE DOOR BRACKET. THE STRAIGHT PORTION OF THE DOOR ARM SHOULD BE AT AN ANGLE OF 15-20° WITH RESPECT TO THE FLOOR WHEN THE DOOR IS CLOSED.

- 3. THE EMERGENCY RELEASE HANDLE AND CORD ARE SECURE TO THE EMERGENCY RELEASE LEVER. THE HANDLE IS LOCATED 6 FT ABOVE FLOOR LEVEL AND REQUIRES NO MORE THAN 50 LBS. PULL TO ACTUATE. THE TROLLEY AND RELEASE MECHANISM ARE PROPERLY LUBRICATED.**
- 4. THE STANDARD WALL PUSH BUTTON OR THE SUPER STATION (DELUXE WALL PUSHBUTTON STATION) IS IN SUCH A POSITION AND OF SUCH A HEIGHT THAT IT CAN ONLY BE ACTUATED BY AN ADULT OF AVERAGE HEIGHT. THE CAUTION LABEL IS PROMINENTLY DISPLAYED NEXT TO THE PUSH BUTTON OR WALL STATION.**
- 5. ALL WIRING IS CORRECT TO CODES OR BETTER. THERE IS GROUND CONTINUITY IN THE SUPPLY. THE GROUND PRONG ON THE POWER CORD IS INTACT.**
- 6. ALL ROPES HAVE BEEN REMOVED FROM THE DOOR. THE DOOR MOVES FREELY WITHOUT BINDING WHEN RAISED OR LOWERED MANUALLY. THE DOOR IS CORRECTLY BALANCED AND LUBRICATED. ALL DOOR HARDWARE IS SECURE AND SOUND. THE SENSITIVITY HAS BEEN ADJUSTED TO MINIMUM FORCE FOR THE APPLICATION. THE APPROPRIATE WARNING STICKER HAS BEEN AFFIXED TO THE DOOR.**
- 7. THE DOOR REVERSES ON OBSTRUCTIONS TO WITHIN 1-1/2" OF THE FLOOR. THE CONCRETE OR OTHER SURFACE BENEATH THE CLOSED DOOR PROVIDES UNIFORM CONTACT.**
- 8. THE PLASTIC ENVELOPE FOR THIS MANUAL IS ATTACHED TO THE WALL NEAR THE PUSH BUTTON OR WALL STATION AND THIS MANUAL IS PLACED THERE FOR OWNER USE AND REFERENCE.**
- 9. ON DOORS WITH EXTENSION TYPE COUNTERBALANCE SPRINGS, RESTRAINT CABLES HAVE BEEN INSTALLED THROUGH THE SPRINGS.**
- 10. THERE IS GFI PROTECTION ON THE LINE TO POWER THE OPENER OR IN THE RECEPTACLE. THIS IS PARTICULARLY IMPORTANT ON INSTALLATIONS INVOLVING DOORS OF STEEL CONSTRUCTION.**
- 11. ON DOORS WITH ADJUSTABLE BOTTOM EDGES, LOCK EDGES HAVE BEEN LOCKED AFTER ADJUSTMENT**



USE EXTREME CAUTION AT ALL TIMES WHEN ATTEMPTING TO DIAGNOSE AND RECTIFY PROBLEMS WITH YOUR GARAGE DOOR OPENER. BEFORE ATTEMPTING ANY SERVICE ON UNIT, DISCONNECT OPENER FROM POWER SUPPLY. YOUR GARAGE DOOR IS THE LARGEST MOVING OBJECT IN YOUR HOUSE, AND THE SPRINGS, PULLEYS, CABLES AND MOUNTING HARDWARE UTILIZED TO BALANCE ITS OPERATION ARE UNDER EXTREME TENSION AT ALL TIMES AND CAN CAUSE SERIOUS PERSONAL INJURY, EVEN DEATH, IF DISTURBED. CALL AN EXPERIENCED SERVICE PERSON TO MOVE, LOOSEN OR ADJUST DOOR SPRINGS OR HARDWARE.

SYMPTOM:

<p>Opener does not activate</p> <p>Operates with Push Button but not with radio control.....</p> <p>Stops before reaching full Open or Closed position</p> <p>Reverses before reaching Full Close position</p> <p>Reverses after door closes and contacts floor</p> <p>Door opens and closes by itself.....</p> <p>Light will not come on</p> <p>Light will not turn off after Opener runs.....</p> <p>Transmitter has short range</p>	<p>PROBABLE CAUSE/SOLUTION:</p> <p>(1) (2) (3) (4) (5) (6) (7) (15)</p> <p>(8) (9) (21) (12) (23)</p> <p>(3) (5) (6) (10) (11) (13) (14) (23)</p> <p>(6) (11) (14)</p> <p>(16) (17)</p> <p>(3) (18) (23)</p> <p>(19) (7)</p> <p>(20) (7)</p> <p>(8) (21) (12) (23)</p>
--	---

PROBABLE CAUSE:

1. Mechanical door lock enabled
2. 120 Volt power not present at outlet
3. Broken or shorted Push Button, wiring or radio receiver

4. Grid lock on Motor Control Board
5. Motor Thermal Overload Protector opened
6. Door jammed due to broken or incorrectly adjusted spring

7. Defective Motor Control Board
8. Weak Battery in Transmitter
9. Radio Coding Switches mismatched
10. Improper placement of Limit Cams on Chain
11. Door obstructed
12. Defective Transmitter or Receiver
13. Up sensitivity force improperly adjusted
14. Down sensitivity force improperly adjusted
15. Bottom of door frozen to ground
16. Ice and snow built up under door
17. Floor risen or sunk from weather change
18. Someone in area with identical code
19. Defective or burned out lamp bulb
20. Radio Receiver not receiving signal

21. Transmitter location in car

SOLUTION:

1. Disable or remove all door locks.
2. Check wall switch, fuse box, circuit breaker, etc.
3. Remove Push Button wiring and Radio Receiver from the terminal strip on the back panel of the operator. Activate Opener by momentarily connecting Terminals 1 & 2 with a test wire. If Opener runs, reconnect items one at a time to find defective circuit. Replace.
4. Unplug Opener, then reconnect.
5. Wait 30 minutes for Motor to cool, try again.
6. Ensure that door is in a closed position. Activate Emergency Release Mechanism. If Opener will run without door attached, contact your Allstar garage door professional to repair door.
7. Contact your local Allstar garage door professional.
8. Replace Battery.
9. Reset Switches to identical codes (See instructions).
10. See instructions for proper placement of Limit Cams.
11. Remove all obstructions from door area.
12. Contact your Allstar garage door professional.
13. Adjust sensitivity. See instructions.
14. Adjust sensitivity. See instructions.
15. Activate Emergency Release, clear away ice.
16. Clear away ice and snow to allow door to close.
17. See instructions to reset Down Limit Cam.
18. Reset all radio controls to new code.
19. Replace with rough service bulb (60W max.)
20. Ensure that antenna wire from Opener is pointing straight down toward the floor.
21. Ensure Transmitter is clipped to sun visor. If it is clipped to dashboard or in ashtray, etc., range will be diminished.



Manufacturer's Limited Warranty

Allstar warrants its 6000 Series residential vehicular garage door operators as follows:

A. The drive train to be free from defects in materials and workmanship for:

Model 6500-P: The entire period of ownership by the original purchaser

Models 6000/6500/J6500: for 20 years from the date of purchase by the original purchaser.

The drive train includes the motor, drive pulleys, drive shaft and sprocket, T-rail, frame and chain.

B. The controller circuit board, capacitor, photobeams and all other parts in all models will be free from defects in materials and workmanship for a period of two (2) years from the date of purchase by the original purchaser.

Contact your dealer to obtain service for your operator .

To obtain service under this warranty the buyer must obtain authorization instructions for the return of any goods from Allstar before returning the goods. The goods must be returned with complete identification, with copy of proof-of-purchase, freight prepaid and in accordance with Allstar's instructions or they will not be accepted. In no event will Allstar be responsible for goods returned without proper authorization or identification.

Goods returned to Allstar for warranty repair within the warranty period, which upon receipt by Allstar are confirmed to be defective and covered by this limited warranty, will be repaired or replaced at Allstar's sole option, at no cost and returned pre-paid. Defective parts will be repaired or replaced with new or factory rebuilt parts at Allstar's sole option.

This limited warranty does not cover non-defect damage, damage caused by unreasonable use, damage caused by improper installation or care, vandalism or lightning, fire or excessive heat, flood or other acts of God (including, but not limited to misuse, abuse or alterations, failure to provide reasonable and necessary maintenance), labor charges for dismantling or reinstalling a repaired or replaced unit, or replacement batteries.

These warranties are in lieu of all other warranties, either expressed or implied. All implied warranties of merchantability and/or fitness for a particular purpose are hereby disclaimed and excluded. Under no circumstances shall Allstar be liable for consequential, incidental or special damages arising in connection with the use or inability to use this product. In no event shall Allstar's liability for breach of warranty, breach of contract, negligence or strict liability exceed the cost of the product covered hereby. No person is authorized to assume for Allstar any other liability in connection with the sale of this product.

This warranty gives you specific legal rights. You may also have other rights which vary from state to state. Warranty effective after September 1st, 1998.

For Information:

Phone 610-873-6900 FAX 610-873-6953