

# **Circuit Board User's Manual**

**Model: KZB-13**



**Support@Vipergatesystems.com**

Control board scheme

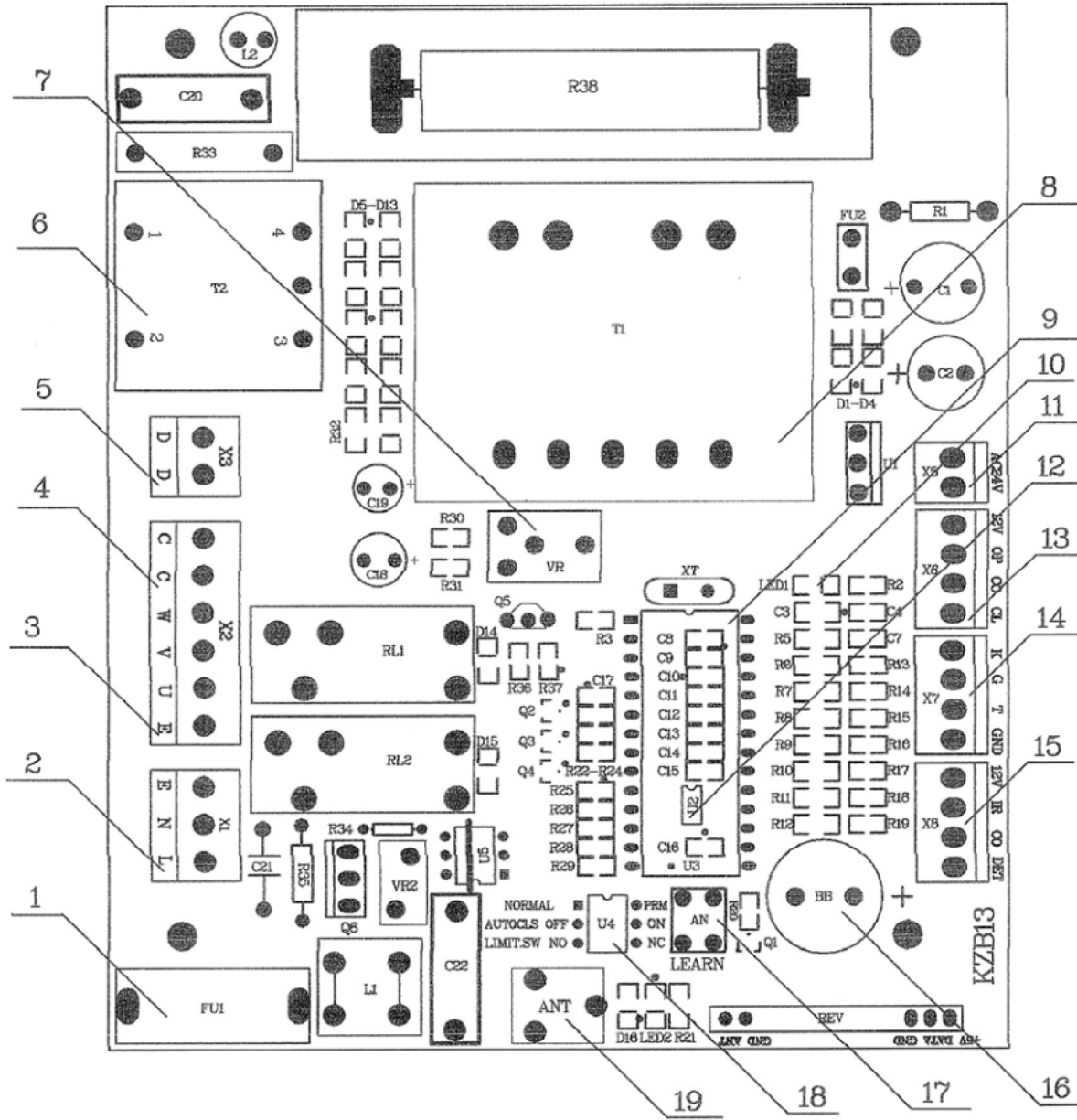
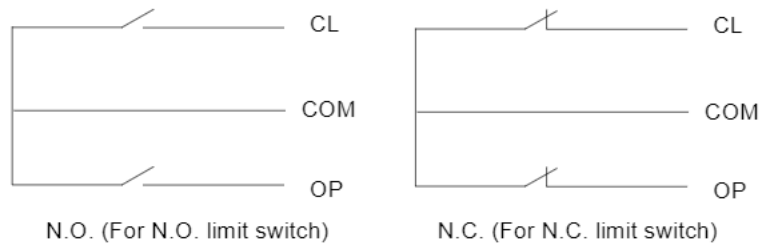

Fig.7

**Wiring notes for control board**

1. Fuse: 10A, Ø5x20
2. Power input: E (Earth), L (Live), N (Neutral) AC110V
3. Motor: U (com), V (Positive direction), W (Opposite direction), E (grounding)
4. Capacitor: 14uF
5. Alarm lamp: AC110V
6. Sampling transformer: 220V/12V 1W
7. Force adjustor (VR): Clockwise +, Counterclockwise –
8. Power transformer: 110V/12VX12V
9. MCU: PIC 16C57C
10. Power indicator: LED
11. Output power supply: AC24V
12. Memory card: 93C66
13. Limit switch: CL (Close limit), CO (Com), OP (Open limit), DC12V (Output power supply)



Limit switch mode is adjustable by DIP-switch. (See table 3)

**Schematic diagram**

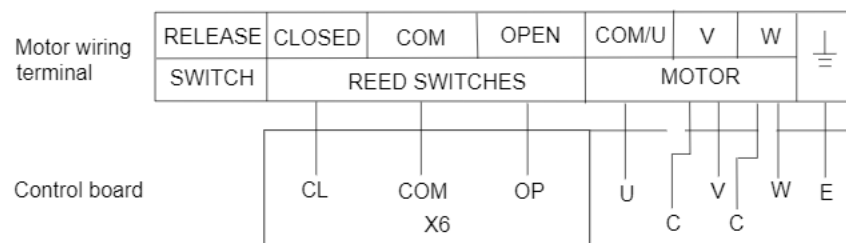

**Wiring diagram**

14. Single-button switch / Keypad (normally open, single-button mode): T (Not used), G (Open priority), K (Open/stop/close), GND(Common)

To install the keypad attach one lead of your keypad to 'K' of terminal X7 and the other to the 'GND'. The keypad will function in single channel mode.

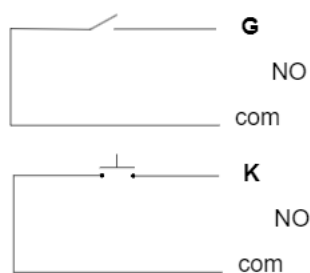

Schematic diagram

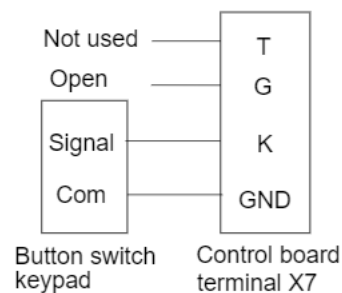

Wiring diagram

15. Output power supply: +12V (DC +12V), COM (CO), DET (Loop detector), I.R. (Infrared N.C)

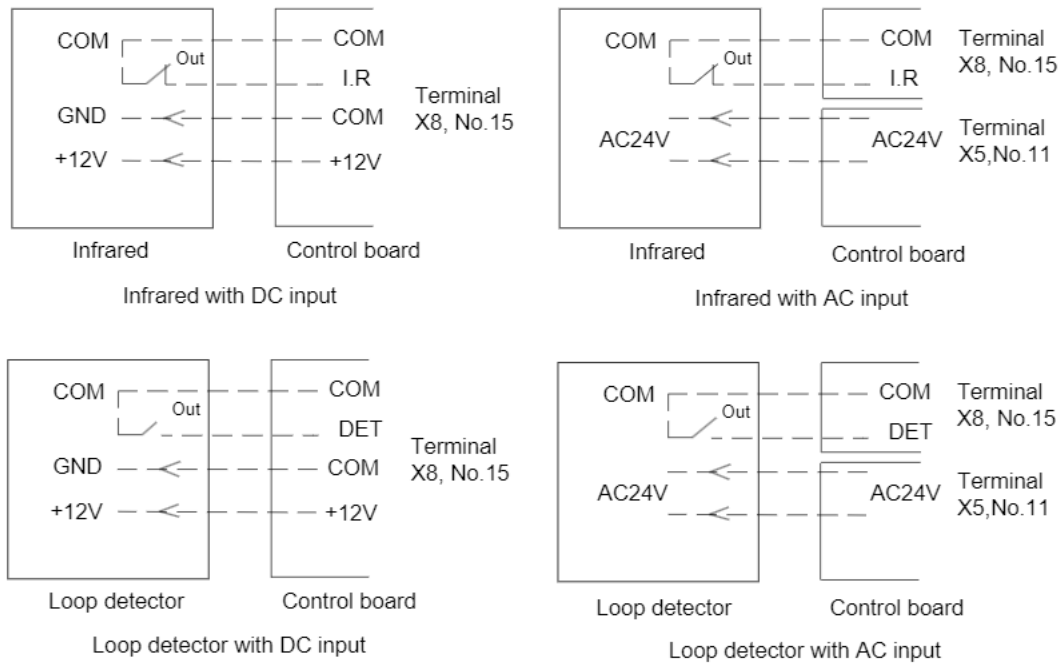

Schematic diagram

- 16. Beeper: DC12V
- 17. Learn button: AN
- 18. Dip-switch
- 19. Antenna: ANT

### 8. Tuning and operation

#### Remote control

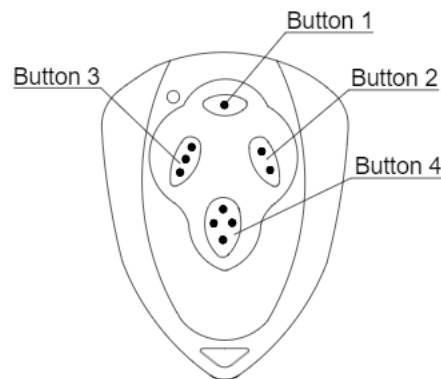

Fig.8

- To add extra remote controls (Learning): Press the button 'AN' (See control board scheme No.17) on the control board, then the 'LED2' will be on and turn off, the beeper will ring about 1 second, then press the remote control button which you want to use, the beeper will ring about 2 seconds and the 'LED2' will turns on about 2 seconds and then turns off. The learning process is finished. Up to 100 remote controls may be used.

- To erase all existing remote controls, press and hold 'AN' button about 14 sec until the beeper stops ringing. This indicates that all the remote controls have been erased completely.
- The remote control works in a single channel mode. It has four buttons. The function of button 1, button 2 and button 3 are the same. With each press of the remote control button which has been programmed, the gate will open, stop, close or stop cycle.
- Button 1, button 2 and button 3 are used to open or close the gate. Button 4 is available to set pedestrian mode. Note: if you canceled the pedestrian mode, the function of button 4 is same as the other three buttons.
- Warning: Notify the users that the gate is never to be operated unless it is in full view.
- Verify open direction: If the gate does not move in the desired direction, then you will need to reverse the motor operating direction. You can do this by exchanging wires 'V' and 'W', 'OP' and 'CL', then insert the wire connector terminal block.

Table3 DIP switch  
(See Fig.7 No.18)

Position	Dip Switch	Function
1	ON	Programming / In this position the control board is in programming condition, NOT USE condition.
	OFF	Normal / In this position the control board can be normally used.
2	ON	Auto-close function and auto-close function of pedestrian mode are available.
	OFF	Both Auto-close function and auto-close function of pedestrian mode are shut off.
3	ON	Limit switch mode is NC.
	OFF	Limit switch mode is NO.

- Set auto-close function (This feature can be selected to make the gate stay open for some time before it automatically closes. The auto-close time can be adjusted to between 0 and 44 seconds.): please turn on the first and the second DIP switch (See Fig.7 No.18) to ON position. Press the remote control button (button 1, button 2 or button 3) that has been programmed to open the gate (see **Verify open direction** section). Stop the gate at any position by pressing the same button, wait for some seconds according to your requirements (the range is 1~44 sec.), this period of time is regarded as 'auto-close time'. Close the gate by pressing the same button. Press the button again to stop the gate or the gate will stop automatically at its closed position if the magnetic limit switch is reached. After this setup is complete, return DIP switch 1 to OFF position immediately. Thus the auto-close function has been set.
- Cancel auto-close function: Please turn on the first and the second DIP switch (See Fig.7 No.18) to ON position. Press the remote control button (button 1, button 2 or button 3) that has been programmed to open the gate (see **Verify open direction** section). Stop the gate at any position by pressing the same button, wait until the gate close automatically (45 sec.). Press the same button to stop the gate or the gate will stop automatically at its closed position if the magnetic limit switch is reached. After this setup

is complete, return DIP switch 1 to OFF position immediately. Thus the auto-close function has been canceled.

- Pedestrian mode: Pedestrian mode can be used to open gate about 0.3~1.5 meters for people pass through.  
\*Set width of pedestrian mode: Please turn on the first and the second DIP switch (See Fig.7 No.18) to ON position. Press button 4 to open the gate (see **Verify open direction** section), Wait until the gate travels the distance according to your requirements (the distance range is 0.3m~1.5m or wait for 3~10 sec.), it is regarded as 'the width of pedestrian mode'. Then press the same button/button 4 to stop the gate, wait for some seconds (1~ 44 sec.). Close the gate by pressing the same button/button 4. Press the same button again to stop the gate or the gate will stop automatically at its closed position if the magnetic limit switch is reached. After this setup is complete, return DIP switch 1 to OFF position immediately. Thus the **width of pedestrian mode** has been set. If you open the gate with button 4, the gate will stop at the expected position that you have set.  
\*Set auto-close function of pedestrian mode: Please turn on the first and the second DIP switch (See Fig.7 No.18) to ON position. Press button 4 to open the gate (see **Verify open direction** section), wait some seconds (3~10 sec.). Then press the same button/button 4 to stop the gate, wait some seconds according to your requirements (1~44 sec.), this period of time is regarded as 'auto-close time of pedestrian mode'. Close the gate by pressing the same button/button 4. Press the same button again to stop the gate or the gate will stop automatically at its closed position if the magnetic limit switch is reached. After this setup is complete, return DIP switch 1 to OFF position immediately. Thus the **auto-close function of pedestrian mode** has been set.  
Note: the new width of pedestrian mode has been re-programmed in the device and replaced the original width you have set in **Set width of pedestrian mode** section. If you open the gate with button 4, the gate will stop at the new expected position that you have set, after some seconds as what you have set, the gate will close automatically.
- Cancel width / auto-close function of pedestrian mode  
\*Cancel both width and auto-close function of pedestrian mode: Please turn on the first and the second DIP switch (See Fig.7 No.18) to ON position. Press button 4 to open the gate (see **Verify open direction** section). Wait for more than 15 sec.. Then press the same button/button 4 to stop the gate. Wait until the gate close automatically (45 sec.). Press the same button to stop the gate or the gate will stop automatically at its closed position if the magnetic limit switch is reached. After this setup is complete, return DIP switch 1 to OFF position immediately. Thus the width and auto-close function of pedestrian mode have been canceled.  
\*Cancel width of pedestrian mode, keep auto-close function of pedestrian mode: Please turn on the first and the second DIP switch (See Fig.7 No.18) to ON position. Press button 4 to open the gate (see **Verify open direction** section). Wait for more than 15 sec.. Then press the same button/button 4 to stop the gate. Wait some seconds according to your requirements (1~44 sec.). Then press the same button/button 4 to close the gate, press the same button again to stop the gate or the gate will stop automatically at its closed position if the magnetic limit switch is reached. After this setup

is complete, return DIP switch 1 to OFF position immediately. Thus the width of pedestrian mode has been canceled, the auto-close function of pedestrian mode has been reserved.

Note: the new auto-close time of pedestrian mode has been re-programmed in the device and replaced the original auto-close time of pedestrian mode that you have been set in **Set auto-close function of pedestrian mode** section.

\*Keep width of pedestrian mode, cancel auto-close function of pedestrian mode: Please turn on the first and the second DIP switch (See Fig.7 No.18) to ON position. Press button 4 to open the gate (see **Verify open direction** section). Wait some seconds (3~10 sec.), then press the same button/button 4 to stop the gate. Wait until the gate close automatically (45 sec.). Press the same button again to stop the gate or the gate will stop automatically at its closed position if the magnetic limit switch is reached. After this setup is complete, return DIP switch 1 to OFF position immediately. Thus the width of pedestrian mode has been reserved, the auto-close function of pedestrian mode has been canceled.

Note: the new width of pedestrian mode has been re-programmed in the device and replaced the original width.

If you open the gate with button 4, the gate will stop at the expected position that you have set, but the gate will not close automatically.

- Turn on the second DIP switch to OFF position (Factory preset: OFF position), both auto close function and auto-close function of pedestrian mode were shut off.
- Safe guard (Infrared device): If the infrared beam is broken during closing, the gate will reverse and open immediately. The control box is not factory equipped with an infrared device.
- Tuning the auto-reverse safety function: rotate the 'Force Adj. VR' knob (See Fig.7 No.7) with a screwdriver. The resistance may be increased or decreased by rotating clockwise or counterclockwise. NOTE: if the gate fails to reverse in the event of obstruction, then the opening force or closing force should be checked for conformity with requirements and adjusted accordingly. The gate will reverse if obstructed when closing, and will stop if jammed when opening.  
Please exchange wires 'V' and 'W' if the auto-reverse direction is wrong. Exchange wires 'OP' and 'CL' if the limit direction is wrong.
- **WARNING:** Do not attempt to tune the gate by placing your hand, arm or other body part in the path of the gate, as serious injury could result. Damage to the gate operator motors may also occur by placing a heavy immovable object in the path during the testing phase. Instead, place a light object in the path (e.g., a chair or trash can) which can be pushed out of the way without causing damage to gate motors, if the setting is still too high. Note: This auto reverse function should be regularly inspected and adjusted if necessary. Once the tuning is complete you may replace the cover.

#### Activities Covered in this section

- **Remote control (Single-button mode):** With each press of the button, the gate will open, stop, close or stop cycle.

- **Single-button/keypad(not supply):** with each press of the button, the gate will close, stop, open or stop cycle.
- **Auto-reverse function:** After adjusting the opening force and closing force, the gate will reverse and go open if obstructed when closing, and will stop if jammed when opening.
- **Auto-close function:** This feature can be selected to make the gate stay open for several seconds before it automatically closes. The auto-close time can be adjusted to between 0 and 44 seconds.
- **Pedestrian mode:** This feature can be used to open gate about 0.3~1.5 meters for people pass through.
- **Safe guard (Infrared photocell):** If infrared beam is broken during closing, the gate will reverse and go open immediately. This feature will not function if the gate is in fully opened and closed positions or during opening.
- **Open priority:** The gate will return to open if press 'OPEN' button of external button switch during closing.
- **Loop detector:** If loop detector detects vehicles during closing, the gate will reopen immediately and stay open until the vehicles move out of the loop. After vehicles move out of the loop, the gate will stop and then close after 10 seconds.  
If loop detector detects vehicles when the gate stops, the gate will open immediately. After vehicles move out of the loop, the gate will stop and then close after 10 seconds.
- **Limit switch:** The switch is used to accurately stop the gate in the opened and closed positions.  
If the gate stops at opened position when the limit switch is reached, the gate will not move if it receives open signals.  
If the gate stops at closed position when the limit switch is reached, the gate will not move if it receives close signals.

## 9. Check

- Check the power supply, grounding and wiring before running the device.
- Release the clutch with the release key to determine whether or not the gate can be moved manually. If everything is in good working order, tighten the clutch with the key.
- Switch the power on and run the device to ensure that the gate is sliding smoothly.
- Adjust the magnet position until the gate opened and closed properly at the limited positions.
- The motor is only designed to work for less than 5 minutes. If it runs continually for an extended period of time, a thermal protector will stop it because of the high temperature.

## 10. Maintenance

Every six months check the following items for proper operation of the unit.

- Check the chain lubricant and add 2# grease regularly.
- Lubricate shafts and sprockets.
- Keep operator clean at all times.
- Check and tighten anchors bolts.



## 11. Trouble Shooting

Table 4

Trouble	Possible causes	Solutions
Motor only runs in one direction.	The wire connector terminal block becomes loose.	Check wire connector terminal block.
	The limit switch wire connector terminal block becomes loose.	Check limit switch wire connector terminal block. Check the limit switch mode.
By pressing button 1(button 2 or button 3) which has been programmed to open the gate, press the same button again to stop the gate in required position, but the gate will auto-close immediately.	The auto-close time is too short.	Reset the auto-close time. See <b>Set auto-close function</b> section.
When you use button 4 of remote control to open the gate, gate travels too short.	The width of pedestrian mode is too narrow.	Reset the width of pedestrian mode. See <b>Set width of pedestrian mode</b> section.
When you use button 4 of remote control to open the gate, but the gate will auto-close immediately.	The auto-close time of pedestrian mode is too short.	Reset the auto-close time of pedestrian. See <b>Set auto-close function of pedestrian mode</b> section.
The gate will not open or close.	The limit switch wire connector terminal block becomes loose.	Check the limit switch mode (see table 3 DIP switch).
	Connecting wires or terminal blocks are too loose.	Check the connecting wires and terminal blocks.
	Power switch is OFF	Make sure power switch is ON.
Remote control does not work	The indicator light of remote control does not light.	Check the batteries on your remote control.
	Remote control is not suitable for receiver.	After making sure the codes are correct, erase remote controls and then re-program the codes in the device. See <b>Adding extra remote controls (learning)</b> section.
	Broken receive board	Replace receive board.
When you open the gate by using button 1(button 2 or button 3) which has been programmed, gate will stop in mid-travel or reverse before reaching the fully limit position.	The Force Adj. (VR) is adjusted too small.	Check the Force Adj. (VR). Adjust VR to increase force.
	Gate is obstructed.	Remove the obstruction.
The remote control operating distance is too short.	Signals are shielded by the gate.	Link a new antenna (1~1.2m BVR 0.75mm <sup>2</sup> see parts list) to the old antenna. Then fix the antenna on the wall vertically, make sure the total height from the top of antenna to the ground is approx. 1.5m.
The gate opens, but stops and will not return.	<ol style="list-style-type: none"> <li>Please note the two magnet brackets (fixed plate) are different: one is higher and another is lower. Please try to exchange the two brackets position.</li> <li>Please try to exchange the limit switch wires CL (close) and OP (open).</li> </ol>	There are two reed switches inside the magnetic limit switch: one is upper and another is lower. Maybe the magnet position was installed in the middle so it induces both reed switches. Solution: adjust the magnet upper or lower.

